



## Guide

**Table 5. Service Bulletin Guide**

DESCRIPTION AND OPERATION	REVERSE MOTOR PINION WILL NOT DISENGAGE
REVERSE MOTOR STALLS OR SPINS TOO SLOWLY	DISASSEMBLE
REVERSE MOTOR RUNS ON	ASSEMBLE
REVERSE MOTOR INOPERATIVE	NEW LABOR CODE

## DESCRIPTION AND OPERATION

The reverse motor uses battery power to move the vehicle in reverse with the engine running and the transmission in neutral.

The reverse motor is designed for light load, short duration use. Steep inclines, long distance travel in reverse or attempted operation with brakes applied will drain the battery or cause the reverse circuit breaker to trip.

The reverse system is an electrical system with an output drive connected directly to the vehicle drive when in operation. The system uses a:

- Reverse motor.
- Reverse motor solenoid.
- Electrical kit (if equipped, contains Printed Circuit Board (PCB) relay and 2-way switch)
- Reverse control solenoid.
- Reverse Control Module (RCM).
- 150 A manual reset circuit breaker.
- Reverse hand switch (Located in the Right Hand Control Module (RHCM)).

See Figure 1. The reverse motor and attached reverse motor solenoid resembles a starter motor. The assembly is single direction (reverse) only and cannot be used to move the vehicle forward. Voltage to the reverse motor assembly is provided through a 150 A manual reset circuit breaker and the RCM solenoid, in response to the output of the RCM.

## Operation

The Electronic Control Module (ECM) will enable reverse if conditions are correct.

- Reverse switch on RHCM is pressed.
- Transmission is in neutral.
- Vehicle is not moving.
- Parking brake is disengaged and indicator light is not illuminated on Instrument Module (IM).
- Engine running at less than 1,500 rpm.
- No reverse Diagnostic Trouble Codes (DTCs) are present.

Upon enabling reverse function, the ECM will activate the reverse telltale lamp located in the IM (FLHTCUTG) or speedometer (FLRT) and indicate reverse enable status to other modules via a Controller Area Network (CAN) message.

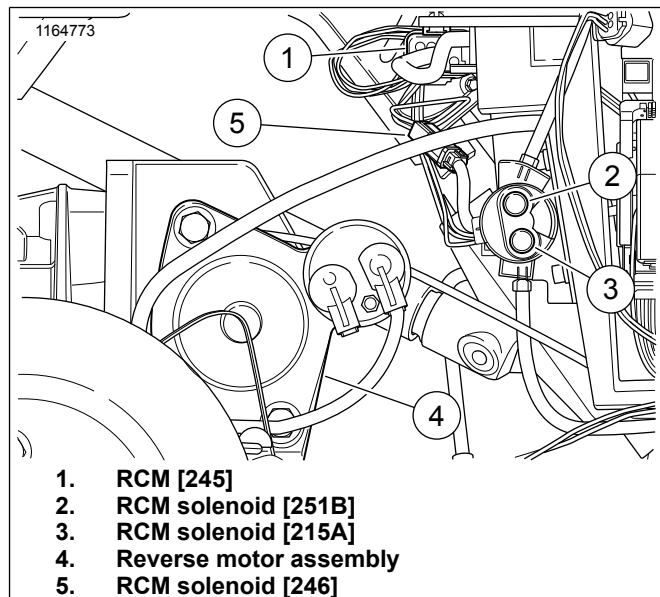
1. Once the reverse enable status is acknowledged by the Body Control Module (BCM), the BCM supplies battery voltage through the (TN/V) wire to RCM [245] terminal 3.
2. The RCM sends a signal to the ECM on the (TN/BE) wire.

3. **Without electrical kit:** See Figure 3. When reverse is enabled, the ECM sends 5 V to the RCM through the (TN) wire. The RCM activates the reverse control solenoid. The control solenoid activates the reverse motor solenoid causing the reverse motor to engage and the vehicle to back up. Reverse is disabled for any of the following conditions:
  - Reverse switch on RHCM is released.
  - Transmission is shifted into gear.
  - Engine is stopped.

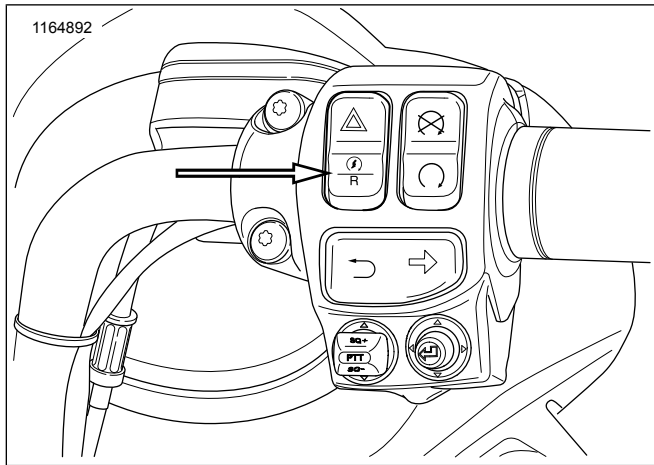
4. **With electrical kit:** See Figure 4. When reverse is enabled, the ECM sends 5 volts to the RCM through the (TN) wire. The RCM activates the reverse control solenoid. The control solenoid activates the reverse motor solenoid. When the reverse motor solenoid is activated, the 2-way switch and PCB relay are signaled. The 2-way switch supplies power to the reverse motor causing the reverse motor to engage and the vehicle to back up. When the reverse control solenoid deactivates, the PCB relay signals the 2-way switch to supply power to the other post of the reverse motor. This momentary voltage releases the tension between the reverse motor gear and drive gear allowing the solenoid to disengage more easily. Reverse is disabled for any of the following conditions:
  - Reverse switch on RHCM is released.
  - Transmission is shifted into gear.
  - Engine is stopped.

**Table 6. Code Description**

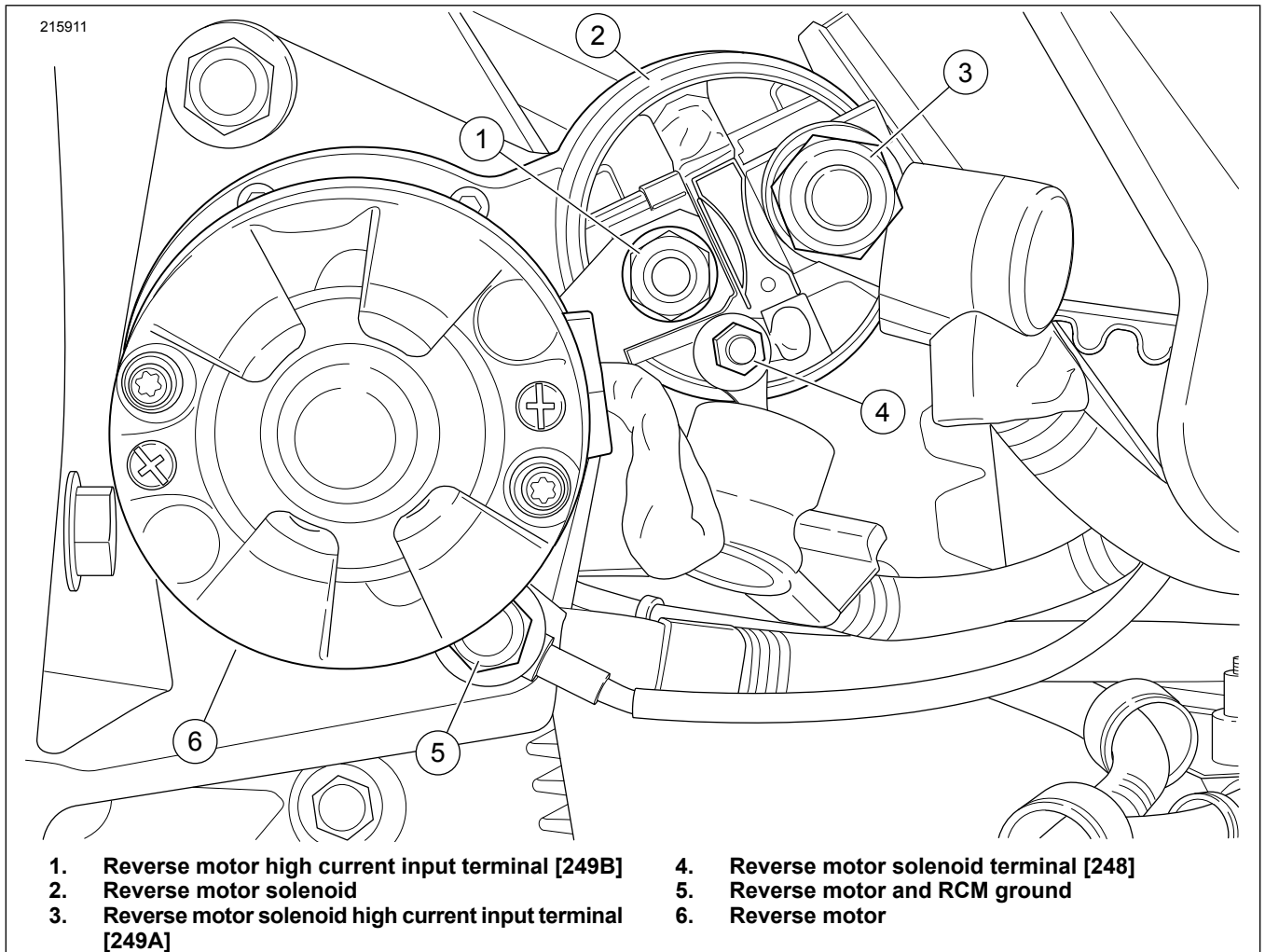
DTC	DESCRIPTION
P1772	Reverse actuator feedback low
P1775	Reverse actuator feedback error
P1777	Reverse actuator low
P1778	Reverse actuator high



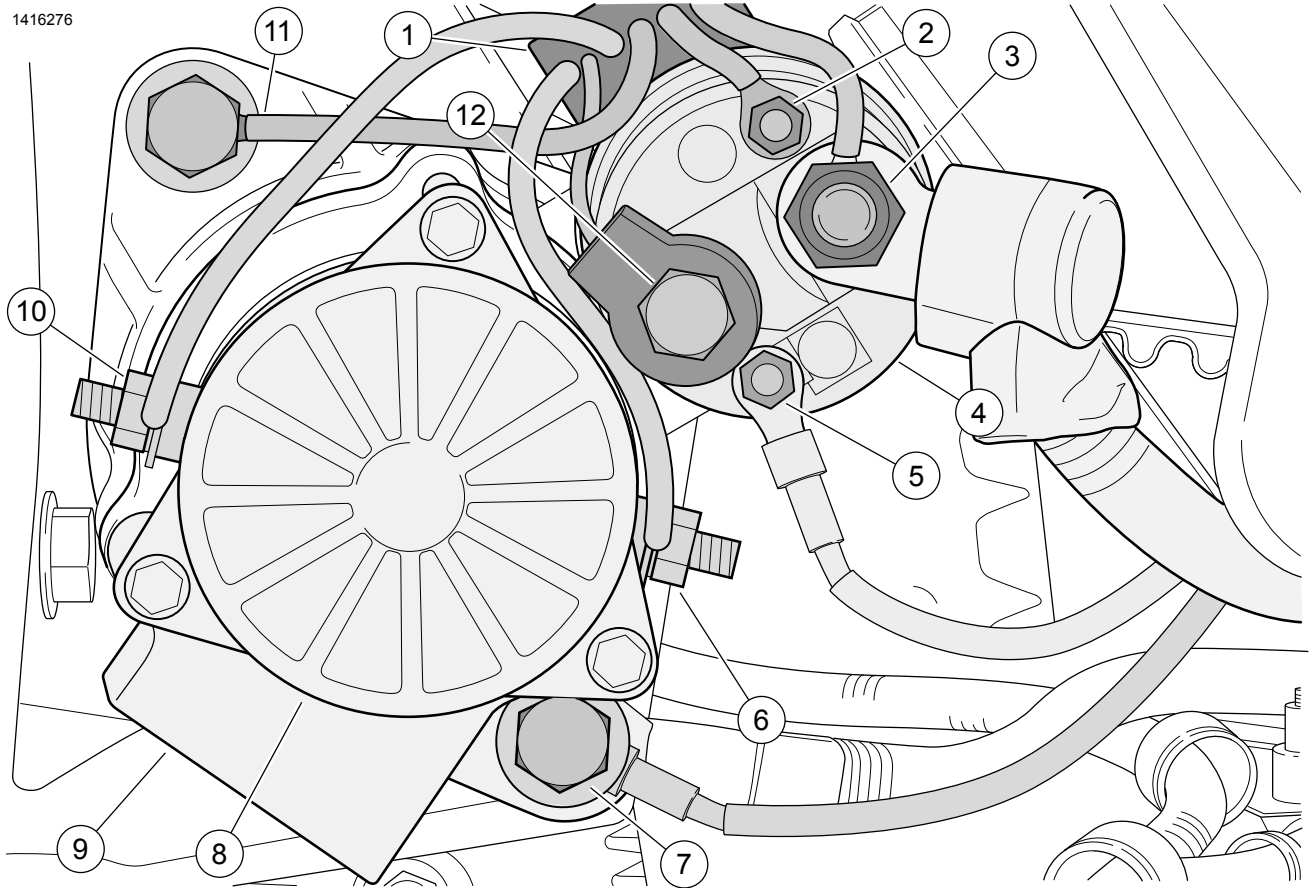
**Figure 1. Typical Reverse System**



**Figure 2. RHCM: Reverse Switch**

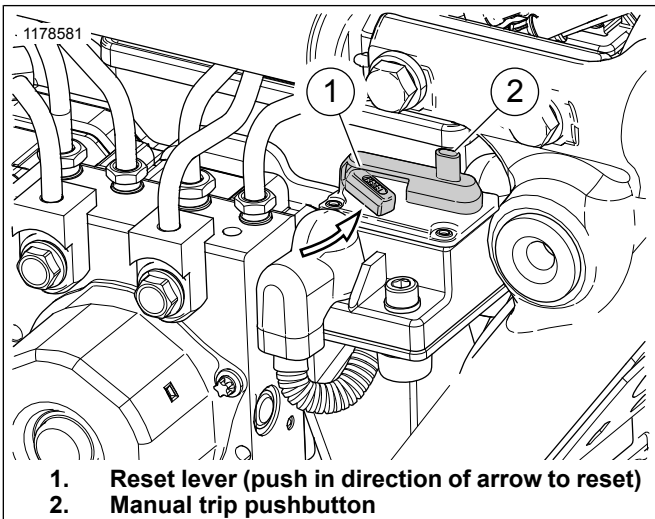


**Figure 3. Reverse Motor without Electrical Kit**



- |  |   |
|--|---|
| 1. K1/K2 switch  | 7. Reverse motor and RCM ground           |
| 2. Terminal [T4]                                       | 8. Reverse motor                          |
| 3. Reverse motor solenoid high current terminal [249A] | 9. PCB relay                              |
| 4. Reverse motor solenoid                              | 10. Reverse motor terminal [T12]          |
| 5. Reverse motor solenoid terminal [248]               | 11. K1/K2 switch ground                   |
| 6. Reverse motor terminal [T7]                         | 12. Reverse motor solenoid terminal [248] |

Figure 4. Reverse Motor With K1/K2 Switch Assembly



1. Reset lever (push in direction of arrow to reset)
2. Manual trip pushbutton

Figure 5. Reverse Motor Circuit Breaker

**Conditions for Settings**

These DTCs will set while attempting to engage reverse.

- Diagnostic Trouble Code (DTC) P1772 will set if ECM [78-3] terminal 4 is shorted to ground.
- DTC P1775 will set if ECM has detected an error within the reverse system.
- DTC P1777 will set if ECM [78-3] terminal 16 is shorted to ground.
- DTC P1778 will set if ECM [78-3] terminal 16 is shorted to battery voltage.

**Diagnostic Tips**

There is no breakout box available for testing the reverse motor system. When performing the diagnostic tests, use the TEST CONNECTOR KIT (PART NUMBER: HD-41404) and a multimeter.

The reverse system may not work properly if battery voltage is lower than 10 V. Connect battery to battery charger before performing any diagnostic tests.

Raise the rear wheels off the ground by placing jack stands under the rear axle before performing any diagnostic tests that require pushing the reverse button.

Before proceeding with diagnostic tests, always:

- Check all fuses.
- Check that battery is fully charged.
- Check that charging system is working properly.
- Check that parking brake is disengaged and indicator lamp is not illuminated.
- Trip and reset the 150 A circuit breaker.

**NOTE**

*See Figure 5. The circuit breaker is manually resettable with a trip pushbutton and a reset lever.*

To manually trip the circuit breaker:

1. Push down on the trip pushbutton.
2. Reset lever will extend out.

**NOTE**

*When the reset lever is extended as shown, the circuit breaker is open/tripped.*

1. To reset, press the reset lever toward the circuit breaker body until an audible click is heard and the lever is fully seated against the circuit breaker body.

2. If the circuit breaker repeatedly opens under non-strenuous loading conditions, or if the reverse motor will not operate after resetting circuit breaker and checking fuses, proceed with diagnostics.

**NOTE**

- *When the circuit breaker trips, the reverse motor pinion gear engages the ring gear. This is normal.*
- *There should be an audible "click" when resetting the circuit breaker. Press the reset switch until it is fully seated against the circuit breaker body.*
- *The reverse enable indicator may remain on while the circuit breaker is open.*

It is very important that the vehicle starts and runs correctly. If the vehicle does not start and run properly, it can cause the reverse system to operate improperly.

**Connector Information**

For additional information about the connectors in the following diagram(s) and diagnostic procedure(s), including the color of the harness test kit terminal probes, see Wire Harness Connectors/General in the service manual supplement.

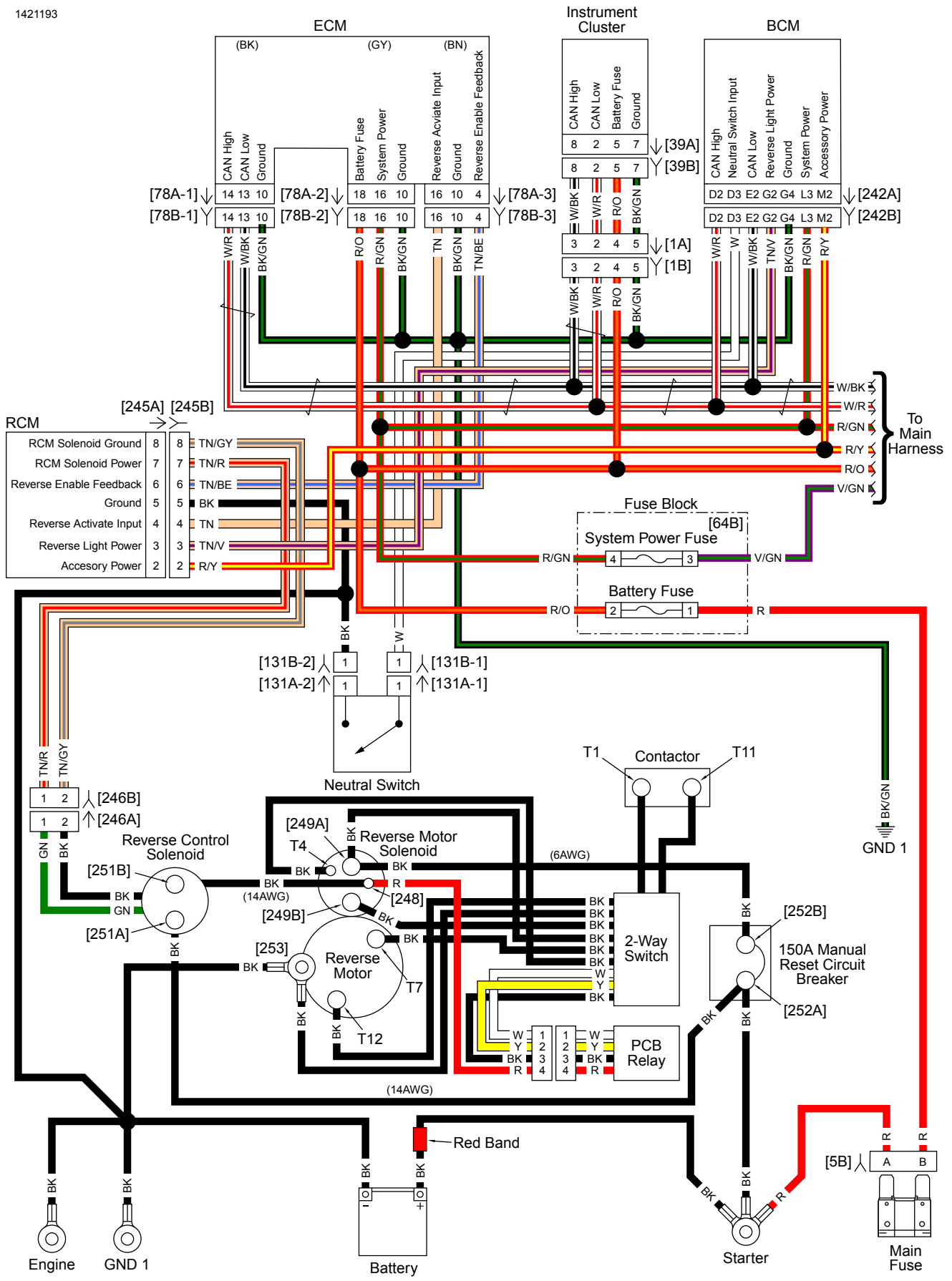


Figure 6. Simplified Reverse Motor System with Switch Assembly: FLHTCUTG



## PINION EXTENDS BUT REVERSE MOTOR STALLS OR SPINS SLOWLY

### NOTE

Raise the rear wheels off the ground by placing jack stands under the rear axle before performing any diagnostic tests that require pushing the reverse button.

A video is associated with this procedure. Refer to Supplemental Procedure Video.

### 1. Reverse Motor Voltage Test

1. Disconnect reverse motor solenoid terminal [249A] and inspect connections.
2. Connect reverse motor solenoid terminal [249A].
3. Test voltage from [249A] to ground.
4. Engage reverse motor.
5. Is battery voltage present?
  - a. **Yes.** Go to Step 2.
  - b. **No.** Continue to section REVERSE MOTOR STALLS OR SPINS TOO SLOWLY.

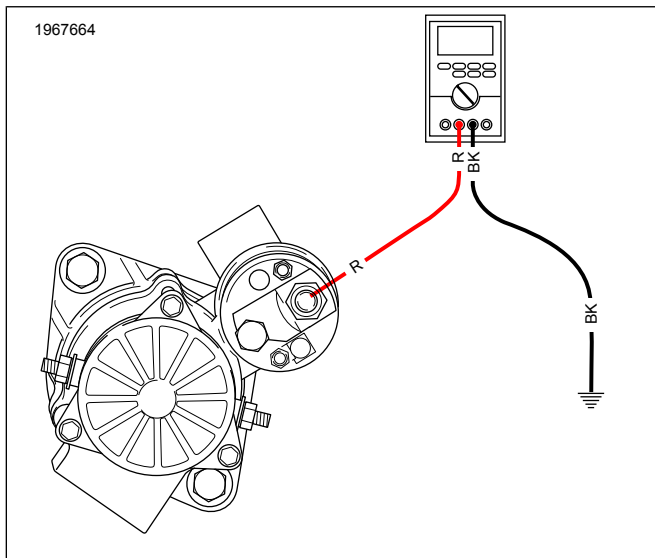


Figure 8.

### 2. K1/K2 Relay Test

1. Remove dust cover on T7.
2. Test voltage from T7 to ground.
3. Engage reverse motor.
4. Is voltage less than 9 V?
  - a. **Yes.** Replace electrical kit.
  - b. **No.** Continue to section REVERSE MOTOR STALLS OR SPINS TOO SLOWLY.

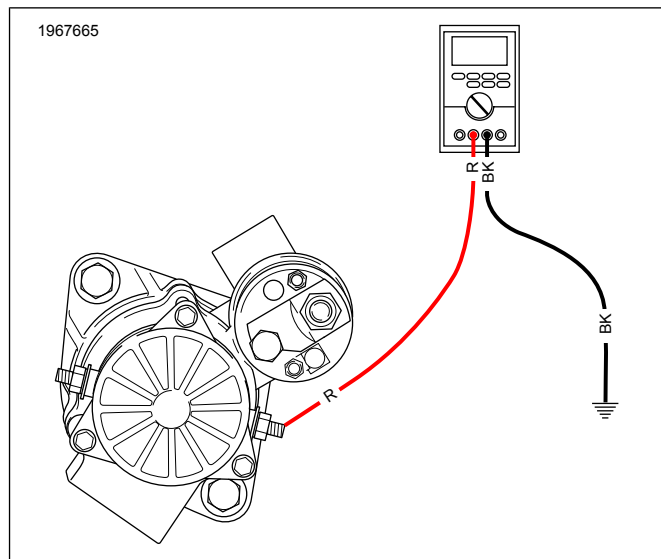


Figure 9.

## REVERSE MOTOR STALLS OR SPINS TOO SLOWLY

### 1. Reverse System Identification Test

1. Inspect 150 A circuit breaker.
2. Reset if necessary.
3. Inspect reverse motor assembly.
4. Does the reverse motor assembly have an electrical kit?
  - a. **Yes.** Go to Step 2.
  - b. **No.** Go to Step 4.

### 2. Reverse Motor Voltage Drop Test

#### NOTE

Raise the rear wheels off the ground by placing jack stands under the rear axle before performing any diagnostic tests that require pushing the reverse button.

1. Perform voltage drop test from battery positive to reverse motor terminal T7 with reverse motor engaged.

2. Is voltage drop greater than 1 V?

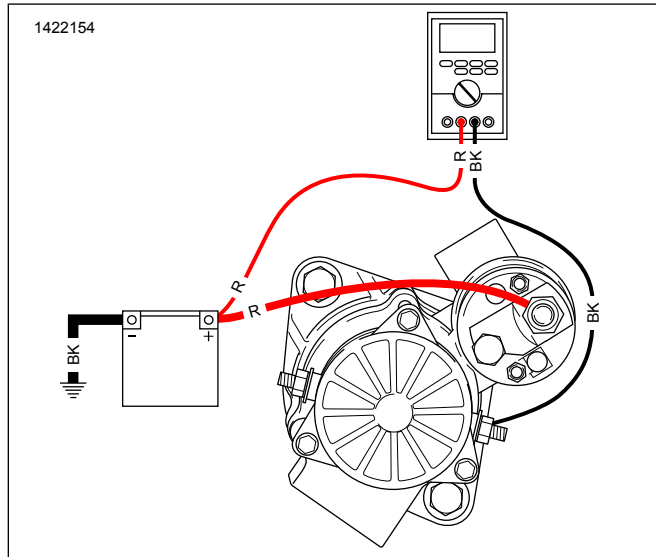


Figure 10.

- a. **Yes.** Go to Step 3.
- b. **No.** Go to Step 8.

### 3. Reverse System Voltage Drop Test

1. Perform voltage drop test from battery positive to reverse motor solenoid terminal [249B] with reverse motor engaged.
2. Is voltage drop greater than 1 V?

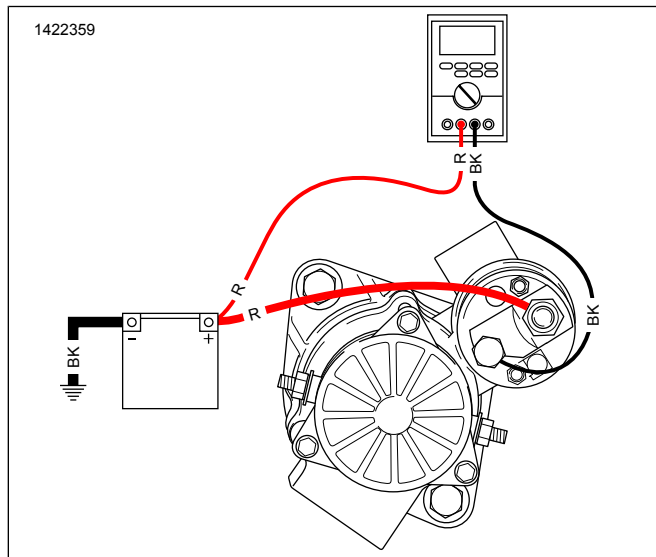


Figure 11.

- a. **Yes.** Go to Step 4.
- b. **No.** Replace electrical kit.

### 4. Reverse Motor Solenoid Voltage Drop Test

1. Perform voltage drop test from battery positive to reverse motor solenoid terminal [249A] with reverse motor engaged.

2. Is voltage drop greater than 1 V?

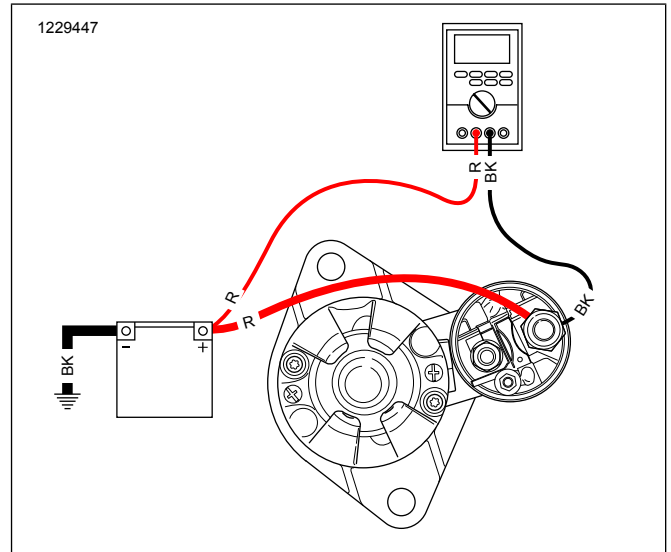


Figure 12.

- a. **Yes.** Go to Step 5.
- b. **No.** Replace reverse motor solenoid.

### 5. Reverse Motor Solenoid Circuit Test

1. Perform voltage drop test from battery positive to reverse motor circuit breaker terminal [252B] with reverse motor engaged.
2. Is voltage drop greater than 1 V?

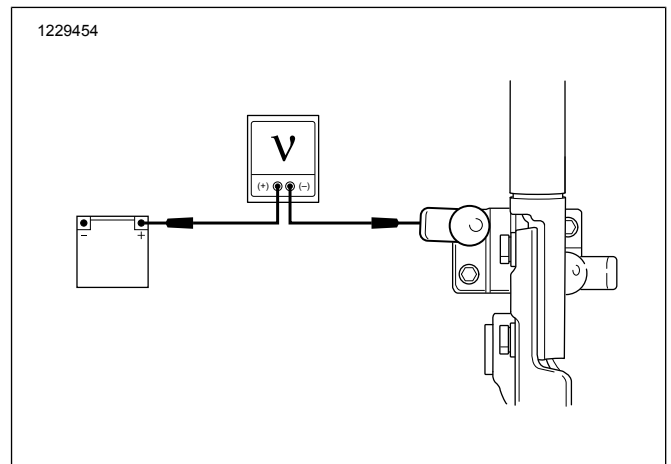


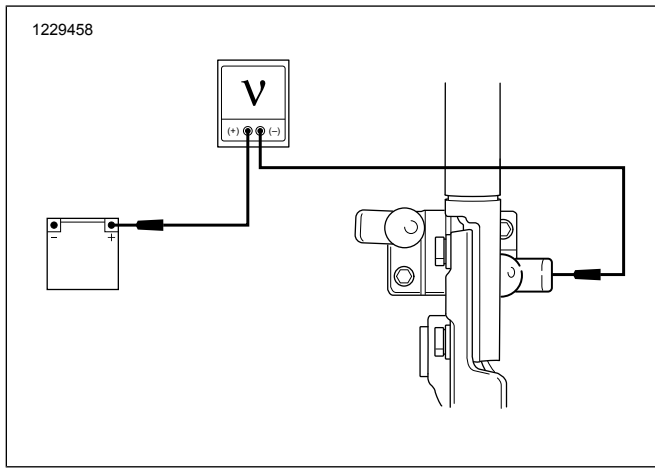
Figure 13.

- a. **Yes.** Go to Step 6.
- b. **No.** Repair/replace circuit breaker to reverse motor solenoid wire.

### 6. Circuit Breaker Voltage Drop Test

1. Perform voltage drop test from battery positive to reverse motor circuit breaker terminal [252A] with reverse motor engaged.

2. Is voltage drop greater than 1 V?

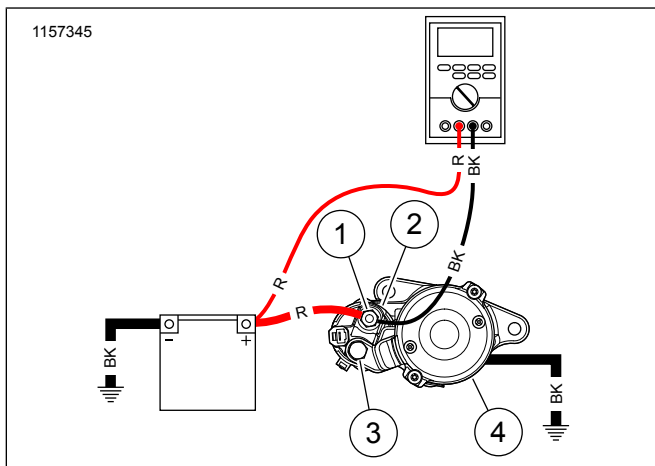


**Figure 14.**

- a. **Yes.** Go to Step 7.
- b. **No.** Replace circuit breaker.

## 7. Vehicle Starter Test

1. Perform voltage drop between battery positive and the high current power from the vehicle starter.
2. Is voltage drop greater than 1 V?



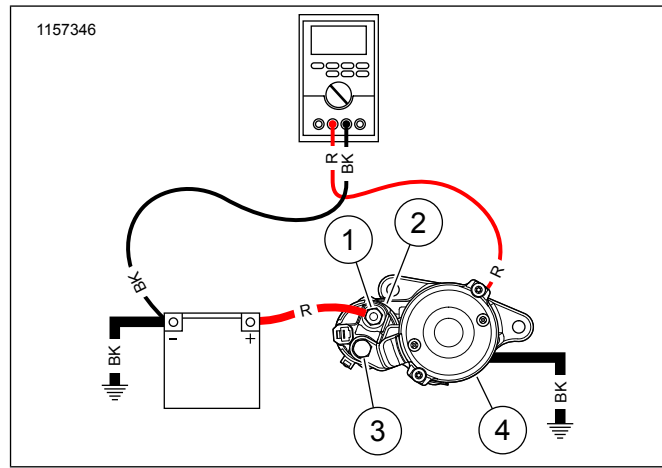
**Figure 15.**

- a. **Yes.** Repair/replace vehicle starter to battery positive wire.
- b. **No.** Repair/replace vehicle starter to circuit breaker wire.

## 8. Ground Circuit Test

1. Perform voltage drop between battery negative and reverse motor mounting bolts with reverse motor engaged.

2. Is voltage drop greater than 1 V?



**Figure 16.**

- a. **Yes.** Clean/repair mounting bolts and mounting surface or ground cable from transmission case to reverse motor mounting bolt.
- b. **No.** Go to Step 9.

## 9. Reverse Motor Current Draw On Vehicle Test

1. Perform reverse motor current draw test on vehicle. See Reverse Motor Test.
2. Are test results within range?
  - a. **Yes.** Go to Step 10.
  - b. **No.** Go to Step 11.

## 10. Reverse Motor Test

1. Perform reverse motor solenoid test. See Reverse Motor Solenoid.
2. Did reverse motor solenoid pass the test?
  - a. **Yes.** Replace reverse motor.
  - b. **No.** Replace reverse motor solenoid.

## 11. Reverse Motor Free Running Current Draw Test

1. Perform reverse motor free running current draw bench test. See Testing Reverse Motor on Bench.
2. Are tests results within range?
  - a. **Yes.** Repair source of mechanical bind.
  - b. **No.** Replace reverse motor.

## REVERSE MOTOR RUNS ON

### 1. Reverse Solenoid Control Circuit Test

1. Trip circuit breaker.
2. Disconnect reverse motor solenoid [248] and inspect connections.
3. Reset circuit breaker.
4. Turn IGN ON.

5. Does reverse motor continue to run on?
  - a. **Yes, without electrical kit.** Replace reverse motor solenoid.
  - b. **Yes, with electrical kit.** Go to Step 5.
  - c. **No.** Go to Step 2.

## 2. RCM Solenoid Circuit Test

1. Turn IGN OFF.
2. Disconnect reverse control solenoid [246] and inspect connections.
3. Turn IGN ON.
4. With reverse drive button not pushed and using TEST CONNECTOR KIT (PART NUMBER: HD-41404), test voltage between [248] and ground.
5. Is battery voltage present?

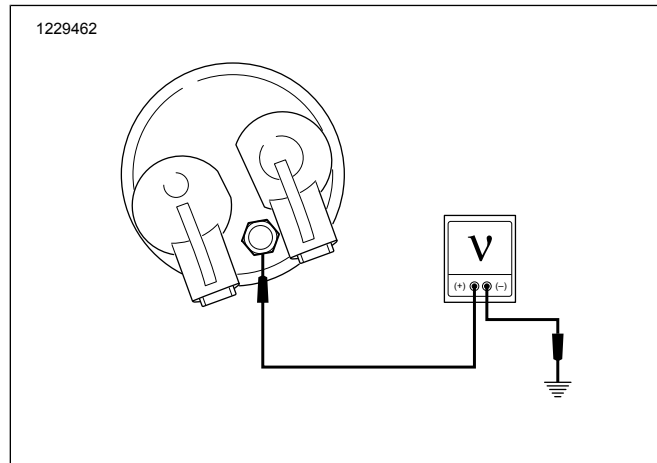


Figure 17.

- a. **Yes.** Go to Step 3.
- b. **No.** Go to Step 4.

## 3. Reverse Motor Solenoid Control Circuit Test

1. Turn IGN OFF.
2. Disconnect reverse control solenoid [251] and inspect connections.
3. Turn IGN ON.
4. With reverse drive button not pushed, test voltage between [248] and ground.
5. Is battery voltage present?
  - a. **Yes.** Repair short to voltage on (BK) wire.
  - b. **No.** Replace Reverse Control Module (RCM) solenoid.

## 4. RCM Solenoid Control Circuit Test

1. Turn IGN OFF.
2. Disconnect RCM [245] and inspect connections.
3. Turn IGN ON.
4. With the reverse drive button not pushed, test voltage between [246B] terminal 1 and ground.

5. Is battery voltage present?

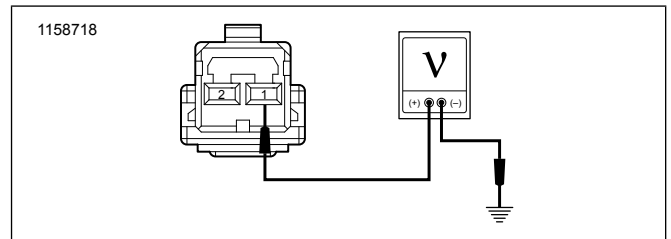


Figure 18.

- a. **Yes.** Repair short to voltage on (TN/R) wire.
- b. **No.** Replace RCM.

## 5. Electrical Kit Test

1. Disconnect [249A] and [249B].
2. Test for continuity reverse motor solenoid terminals [249A] and [249B].
3. Is continuity present?

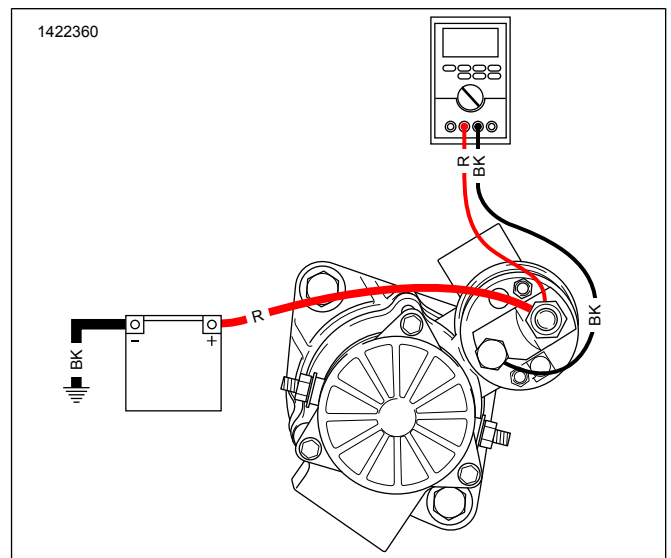


Figure 19.

- a. **Yes.** Replace reverse motor solenoid.
- b. **No.** Replace electrical kit.

## REVERSE MOTOR INOPERATIVE

### 1. Circuit Breaker Reset Test

1. Reset 150 A reverse motor circuit breaker.
2. Verify reverse function.
3. Is reverse motor working?
  - a. **Yes.** Circuit breaker was reset.
  - b. **No.** Go to Step 2.

### 2. Reverse Switch Function Test

1. Verify conditions are correct to enable reverse. See Reverse Motor System Diagnostics.
2. Start engine.
3. Activate reverse button on Right Hand Control Module (RHCM).

4. Does reverse indicator illuminate?
  - a. **Yes. Solid "R"**. Go to Step 3.
  - b. **Yes. Flashing "R"**. Go to Step 16.
  - c. **No**. See Indicator Lamp Diagnostics.

### 3. RCM Circuit Test

#### NOTE

Raise the rear wheels off the ground by placing jack stands under the rear axle before performing any diagnostic tests that require pushing the reverse button.

1. With reverse drive button pressed and using TEST CONNECTOR KIT (PART NUMBER: HD-41404), test voltage between reverse motor solenoid [248] and ground.
2. Is voltage greater than 10 V?

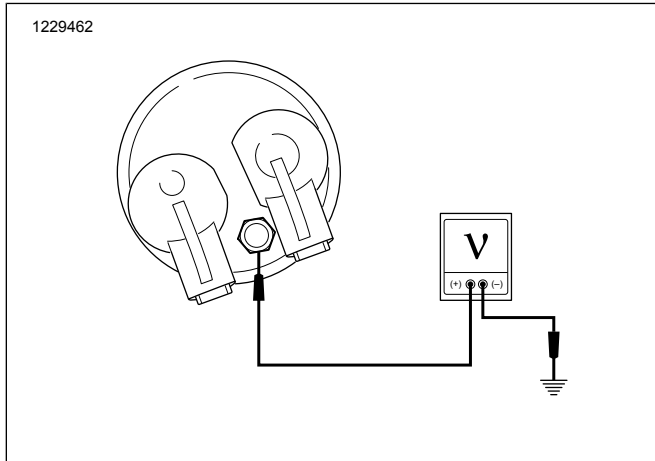


Figure 20.

- a. **Yes**. Go to Step 4.
- b. **No**. Go to Step 7.

### 4. Reverse Motor High Current Circuit Test

1. With reverse button pressed, test voltage between reverse motor solenoid [249B] and ground.
2. Is voltage greater than 10 V?

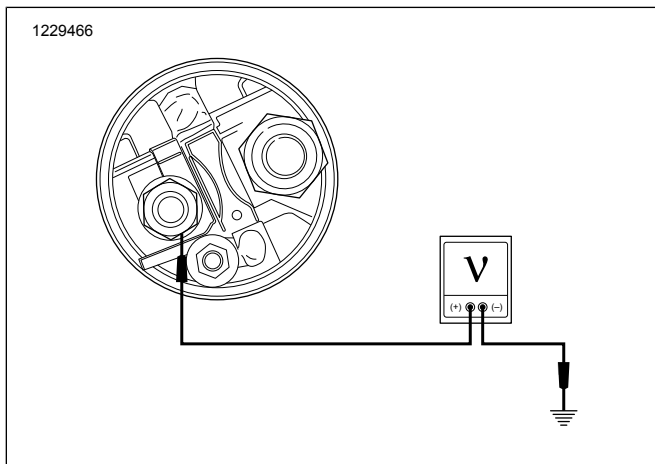


Figure 21.

- a. **Yes**. Go to Step 5.
- b. **No**. Go to Step 13.

### 5. Ground Circuit Test

1. Turn IGN OFF.
2. Test resistance between reverse motor mounting bolt [253] and ground.
3. Is resistance less than 0.5  $\Omega$ ?
  - a. **Yes, without electrical kit**. Go to Step 6.
  - b. **Yes, with electrical kit**. Go to Step 23.
  - c. **No**. Clean/repair mounting bolts and mounting surface.

### 6. Reverse Motor Solenoid Test

1. Perform reverse motor solenoid test. See Reverse Motor Testing.
2. Did reverse motor solenoid pass test?
  - a. **Yes**. Replace reverse motor.
  - b. **No**. Replace reverse motor solenoid.

### 7. Reverse Motor Control Circuit Test

1. Start engine.
2. With reverse button pressed, test voltage between reverse control solenoid [251A & B] and ground.
3. Is voltage greater than 10 V at both terminals?

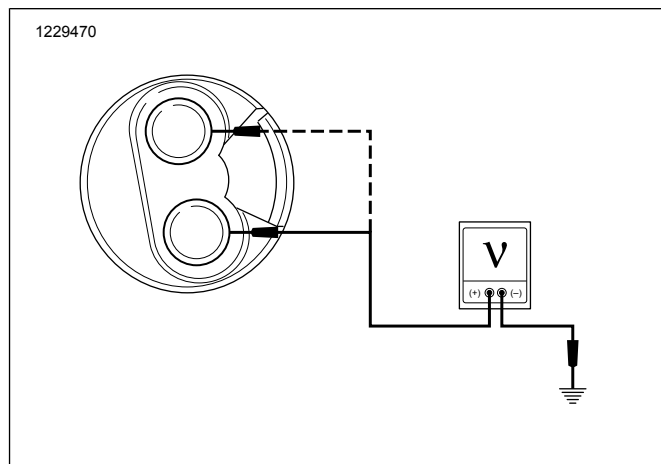


Figure 22.

- a. **Yes**. Repair open between [251B] and [248] (BK) wire.
- b. **No, only terminal [251A]**. Go to Step 8.
- c. **No, neither terminal**. Go to Step 12.

### 8. RCM Solenoid Control Circuit Test

1. Turn IGN OFF.
2. Disconnect [246] and inspect connections.
3. Start engine.
4. With reverse switch pressed, test voltage between [246B] terminal 1 (TN/R) wire and ground.

5. Is voltage greater than 10 V?

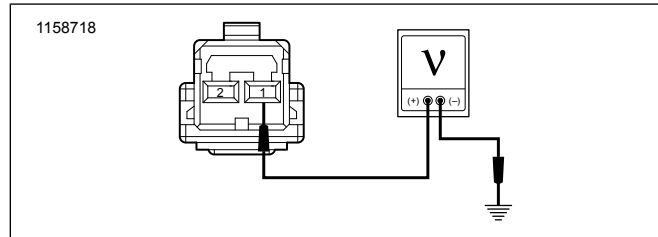


Figure 23.

- a. **Yes.** Go to Step 9.
- b. **No.** Go to Step 11.

### 9. RCM Solenoid Ground Circuit Test

1. Turn IGN OFF.
2. Test resistance between [246B] terminal 2 and ground.
3. Is resistance less than 1  $\Omega$ ?

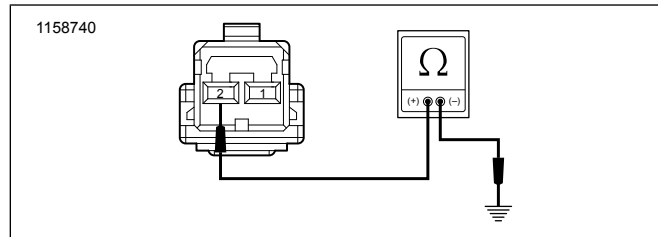


Figure 24.

- a. **Yes.** Replace RCM solenoid.
- b. **No.** Go to Step 10.

### 10. RCM Ground Circuit Test

1. Disconnect [245] and inspect connections.
2. Test resistance between [245B] terminal 8 and [246B] terminal 2 (TN/GY).
3. Is resistance less than 0.5  $\Omega$ ?

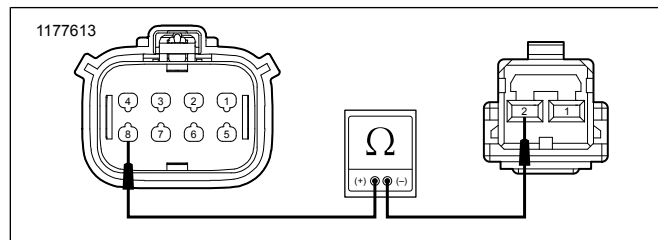


Figure 25.

- a. **Yes.** Replace RCM .
- b. **No.** Repair open in (TN/GY) wire.

### 11. RCM Solenoid Control Circuit Open Test

1. Turn IGN OFF.
2. Disconnect RCM [245] and inspect connections.
3. Test resistance between [246B] terminal 1 and [245B] terminal 7 (TN/R).

4. Is resistance less than 0.5  $\Omega$ ?

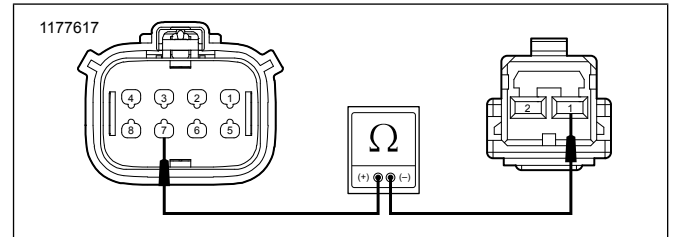


Figure 26.

- a. **Yes.** Replace RCM .
- b. **No.** Repair open in (TN/R) wire.

### 12. Circuit Breaker Supply Voltage Test

1. Test voltage between circuit breaker [252A] and ground.
2. Is voltage greater than 10 V?

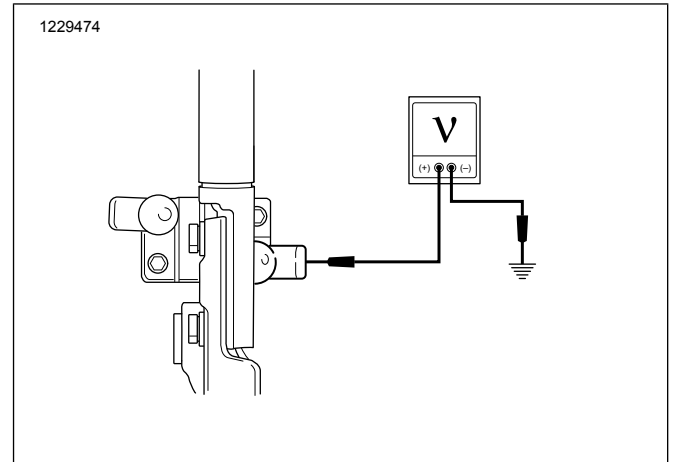


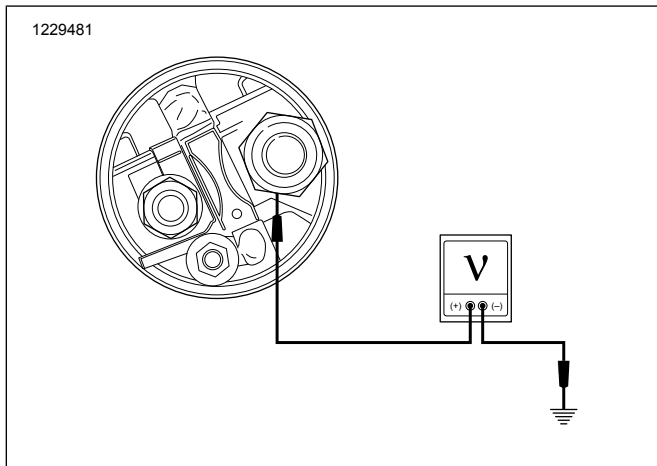
Figure 27.

- a. **Yes.** Repair open between [251A] and [252A] (BK) wire.
- b. **No.** Repair open between [252A] and starter (BK) wire.

### 13. Reverse Motor Solenoid Test

1. Start engine.
2. With reverse button pressed, test voltage between reverse motor solenoid [249A] and ground.

3. Is voltage greater than 10 V?

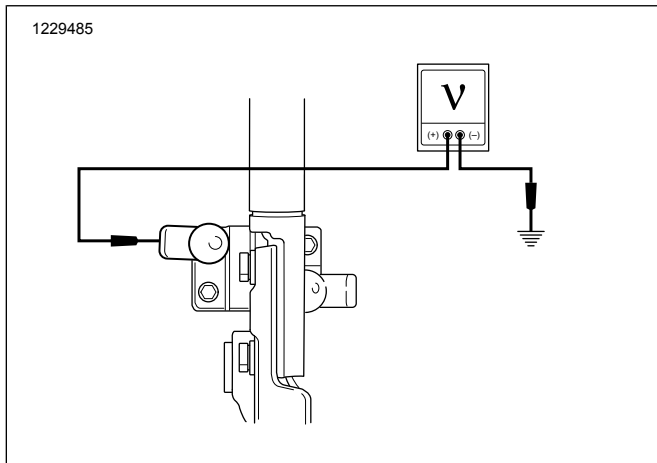


**Figure 28.**

- a. **Yes, without electrical kit.** Replace reverse motor solenoid.
- b. **Yes, with electrical kit.** Go to Step 23.
- c. **No.** Go to Step 14.

#### 14. Reverse Motor Circuit Solenoid Test

1. With reverse button pressed, test voltage between circuit breaker [252B] and ground.
2. Is voltage greater than 10 V?



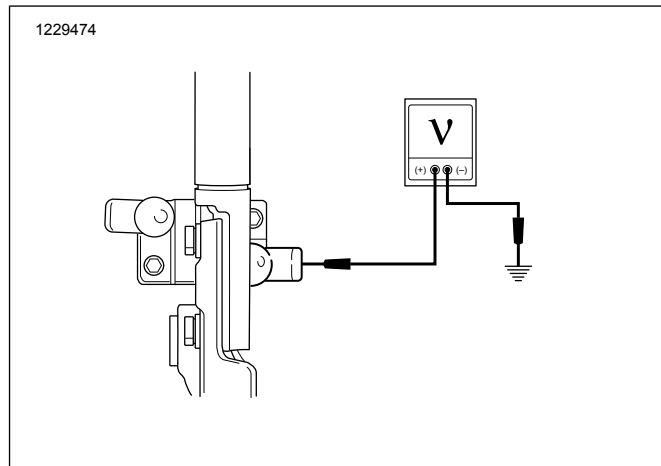
**Figure 29.**

- a. **Yes.** Repair open between [249A] and [252B] (BK) wire.
- b. **No.** Go to Step 15.

#### 15. Circuit Breaker Test

1. With reverse button pressed, test voltage between circuit breaker [252A] and ground.

2. Is voltage greater than 10 V?



**Figure 30.**

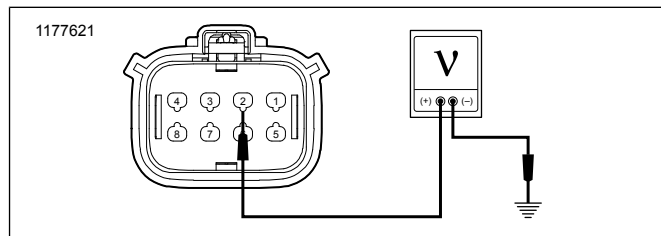
- a. **Yes.** Replace circuit breaker.
- b. **No.** Repair open in (BK) wire between [252A] and starter.

#### 16. Neutral Circuit Test

1. Verify transmission is in neutral.
2. Is neutral lamp functional?
  - a. **Yes.** Go to Step 17.
  - b. **No.** See neutral lamp diagnostics.

#### 17. Accessory Circuit Open Test

1. Turn IGN OFF.
2. Disconnect RCM [245] and inspect connections.
3. Turn IGN ON.
4. Test voltage between [245B] terminal 2 (R/Y) wire and ground.
5. Is voltage greater than 10 V?



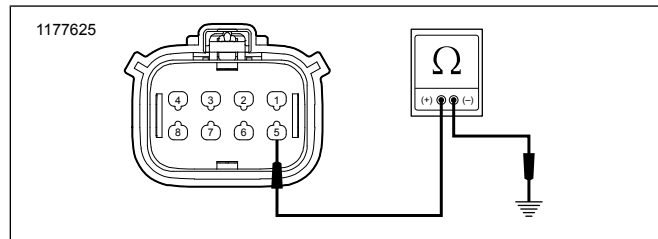
**Figure 31.**

- a. **Yes.** Go to Step 18.
- b. **No.** Repair open in (R/Y) wire.

#### 18. Ground Circuit Open Test

1. Turn IGN OFF.
2. Using TEST CONNECTOR KIT (PART NUMBER: HD-41404), test resistance between RCM [245B] terminal 5 and ground (BK) wire.

3. Is resistance less than 0.5  $\Omega$ ?

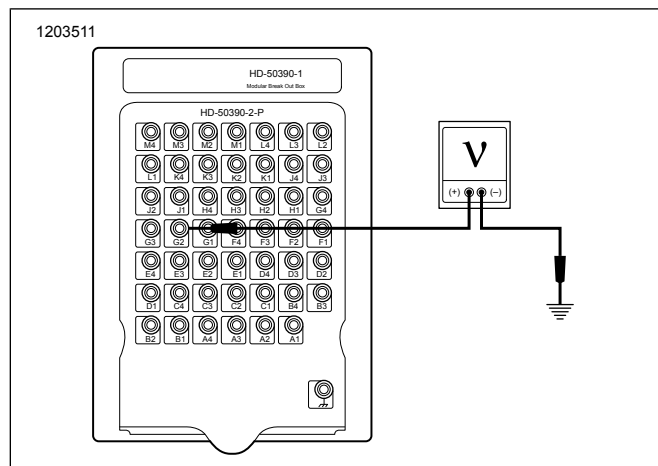


**Figure 32.**

- a. **Yes.** Go to Step 19.
- b. **No.** Repair open in (BK) wire.

### 19. Backup Light Power Test

1. Connect [245].
2. Connect BREAKOUT BOX (PART NUMBER: HD-50390-1) and BCM CABLE (PART NUMBER: HD-50390-2A) to wire harness [242B], leaving [242A] disconnected.
3. Verify BCM OVERLAY (PART NUMBER: HD-50390-2-P) is in position on Breakout Box (BOB).
4. Start engine.
5. With reverse button pressed, test voltage between BOB terminal G2 and ground.
6. Is voltage greater than 10 V?



**Figure 33.**

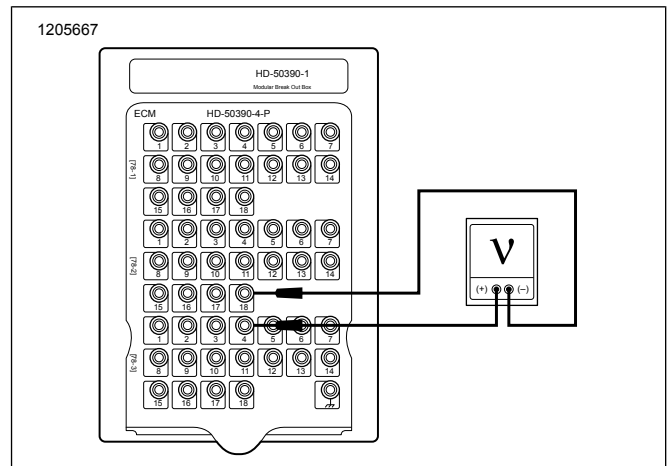
- a. **Yes.** Go to Step 20.
- b. **No.** Replace Body Control Module (BCM).

### 20. Reverse Enable Feedback Test

1. Turn IGN OFF.
2. Remove Body Control Module (BCM) BOB, and connect [242].
3. Connect BREAKOUT BOX (PART NUMBER: HD-50390-1) and ECM CABLE (PART NUMBER: HD-50390-4) between wire harness [78B-1], [78B-2], [78B-3] and ECM [78A-1], [78A-2], [78A-3].
4. Verify ECM OVERLAY (PART NUMBER: HD-50390-4-P) is in position on BOB.
5. Start engine.

6. With reverse button pressed, test voltage between BOB [78-3] terminal 4 and [78-2] terminal 18.

7. Is voltage greater than 10 V?

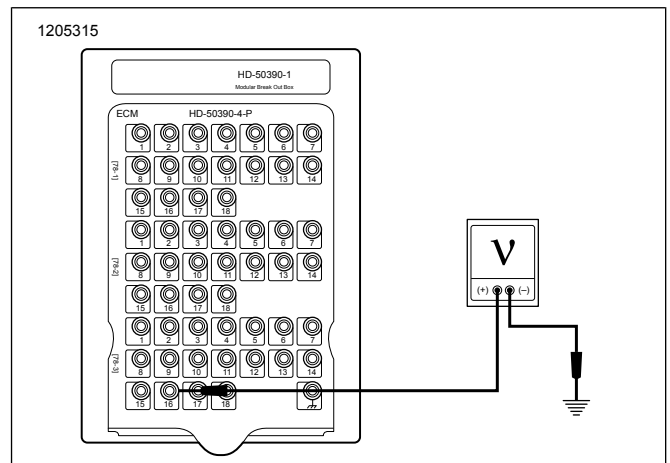


**Figure 34.**

- a. **Yes.** Go to Step 21.
- b. **No.** Replace RCM.

### 21. Reverse Activate Test

1. Press reverse button two times, test voltage between BOB [78-3] terminal 16 and ground.
2. Is voltage between 4–6 V?



**Figure 35.**

- a. **Yes.** Go to Step 22.
- b. **No.** Replace ECM.

### 22. Reverse Activate Input Open Test

1. Turn IGN OFF.
2. Disconnect RCM [245] and inspect connections.
3. Test resistance between BOB [78-3] terminal 16 and [245B] terminal 4.

4. Is resistance less than  $0.5 \Omega$ ?

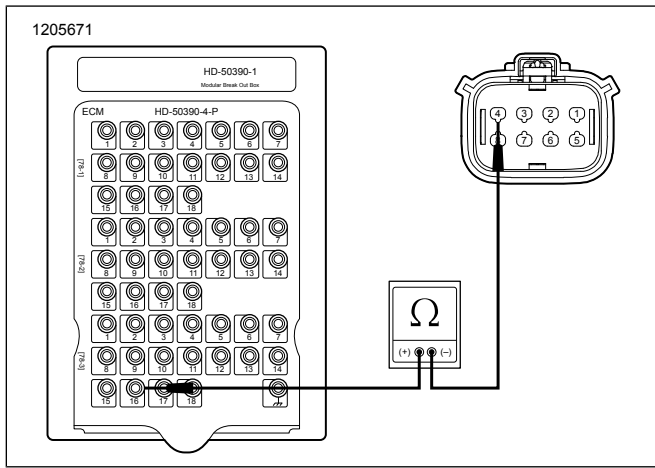


Figure 36.

- a. **Yes.** Replace RCM.
- b. **No.** Repair open in (TN) wire.

### 23. Reverse Motor Test

1. Start engine.
2. With reverse button pressed, test voltage between reverse motor terminal [T7] and [T12].
3. Is voltage greater than 10 V?

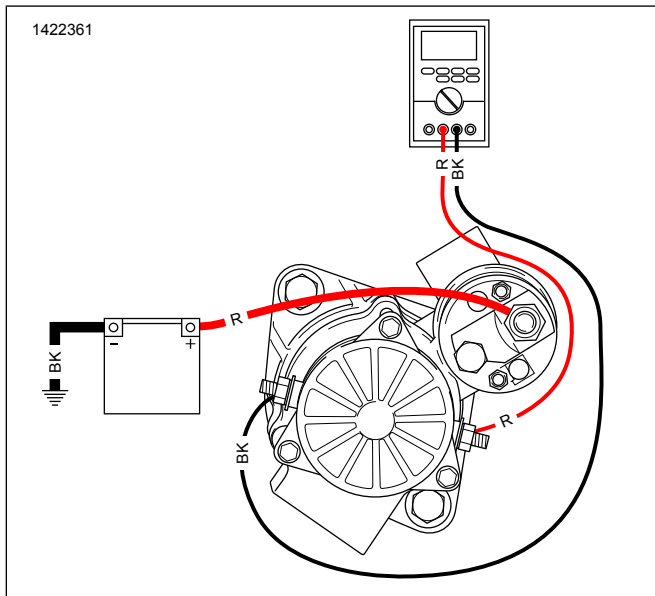


Figure 37.

- a. **Yes.** Replace reverse motor.
- b. **No.** Replace electrical kit.

## REVERSE MOTOR PINION WILL NOT DISENGAGE

### 1. Validation Test

1. Press down the reverse button.

2. Did the trike reverse but the pinion stuck when the button was released?

- a. **Yes.** Go to Step 2.
- b. **No.** System functioning properly.

### 2. Electrical Kit Test

1. Connect a voltmeter to [T12] and [T7] on the reverse motor.
2. Press the reverse button while watching the voltmeter.
3. Release the reverse button while watching the voltmeter.
4. Was battery voltage momentary seen on the voltmeter when the switch was released?

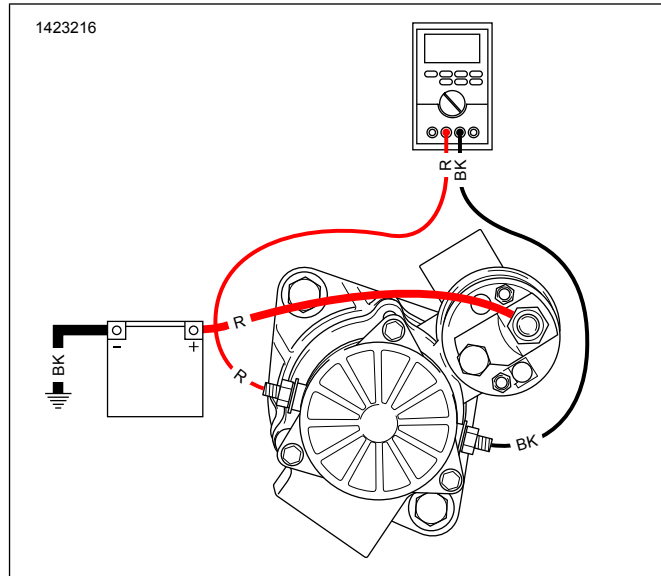


Figure 38.

- a. **Yes.** Replace the solenoid.
- b. **No.** Replace electrical kit.

## DISASSEMBLE

### NOTE

Before disassembling reverse motor, see REVERSE MOTOR TESTING.

### Remove Electrical Kit

1. Remove reverse motor. See Remove in this section.
2. Observe location of cable straps.
3. Discard cable straps securing wiring.
4. See Figure 44. Remove contactor Z.
  - a. Remove mounting screws (1) while holding nuts (6).
  - b. Note wire orientation.
  - c. Remove terminal screws (5) securing wire #11 (4) and wire #1 (3) from Contactor Z.
  - d. Remove Contactor Z (7).

5. See Figure 43. Disconnect wires from reversing switch to solenoid.
  - a. Remove wire #8 (8) nut from solenoid (3).
  - b. Remove wire #5 (5) nut from solenoid.
6. Disconnect wires at reverse motor.
  - a. Retract rubber boots from terminals on reverse motor.
  - b. Remove wire #7 (7) nut from reverse motor (10).
  - c. Remove wire #12 (12) nut from reverse motor.
7. Remove wire #2 (2) nut from solenoid.
8. Disconnect four-way connector (6).
9. Remove wire #4 from solenoid.
  - a. Remove heat shrink from wire #4 (4) screw.
  - b. Remove screw.

10. **NOTE**  
*Lower screw securing solenoid does not need to be removed unless removing solenoid.*

See Figure 42. Remove reversing switch bracket.

- a. Remove screw (1).
  - b. Verify O-ring (4) behind upper bracket (3) remained in place.
  - c. See Figure 43. Remove bracket screw (13).
11. See Figure 43. Remove timing relay.
    - a. Disconnect four-way connector (6).
    - b. Remove timing relay screws (14).

### Remove Solenoid

1. **If necessary:** Remove contactor Z lower screw (4).
2. Remove solenoid, disengaging plunger from lever.

### ASSEMBLE

#### Install Solenoid

1. See Figure 40. Install plunger (2) with slot on arm (1).
2. Install O-ring (4).
3. See Figure 39. Place spring (3) in spring groove (2) on plunger (1).
4. Place solenoid body (3) in position with spring centered.

5. See Figure 41. Install O-ring (1).
6. Position lower bracket (2).
7. Move solenoid toward installed position and install screw (4) with lock washer (3). Tighten finger tight.

8. **NOTE**  
*Verify O-ring is in pocket in reverse motor body under upper bracket.*

See Figure 42. Position upper bracket (3) between o-ring (4) and reversing switch bracket (5).

9. Install screw (1) with lockwasher (2).
10. Tighten both screws.

Torque: 62–80 **in-lbs** (7–9 N·m) *Reverse motor solenoid screws*

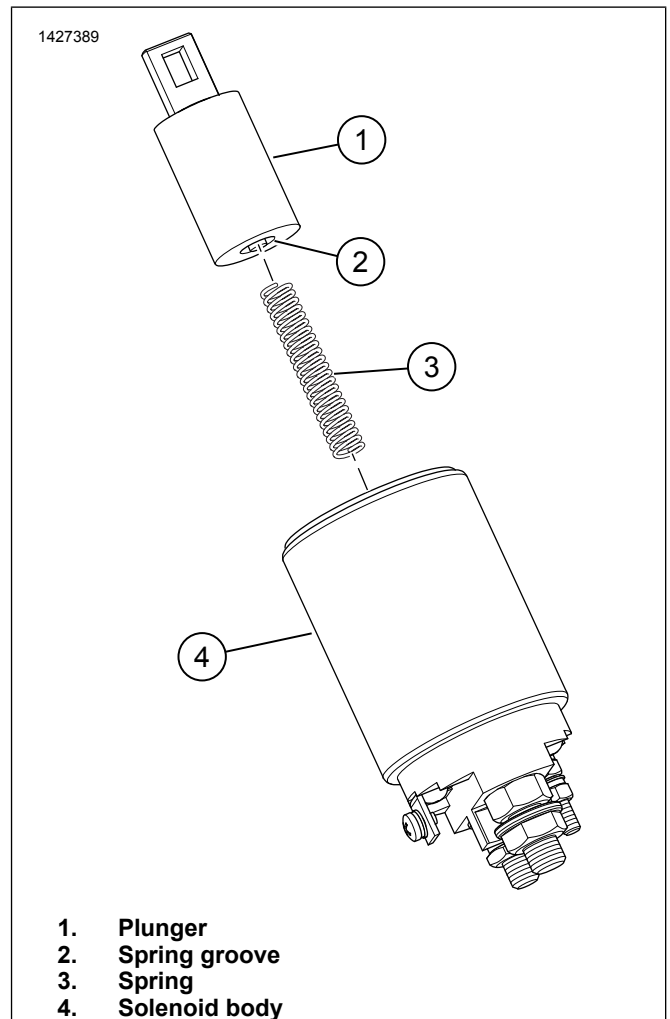


Figure 39. Solenoid Components

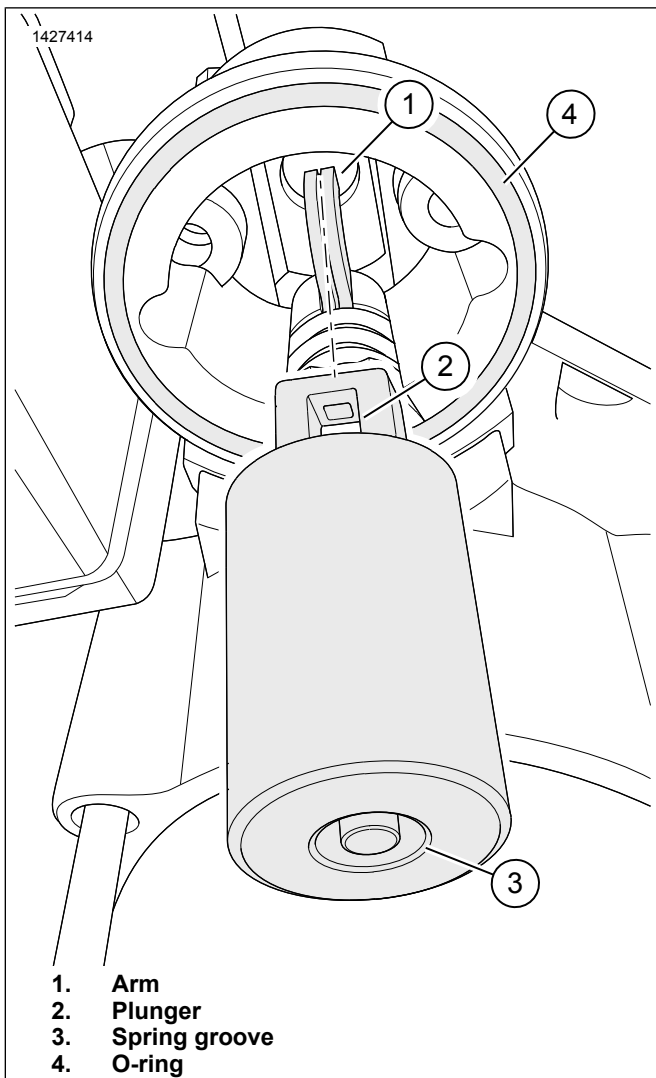


Figure 40. Solenoid Plunger Install

1. Arm
2. Plunger
3. Spring groove
4. O-ring

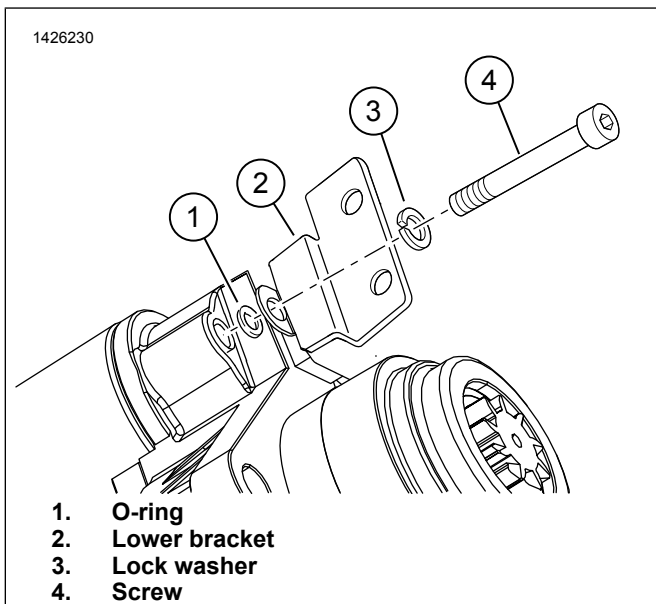


Figure 41. Contactor Z Lower Bracket

1. O-ring
2. Lower bracket
3. Lock washer
4. Screw

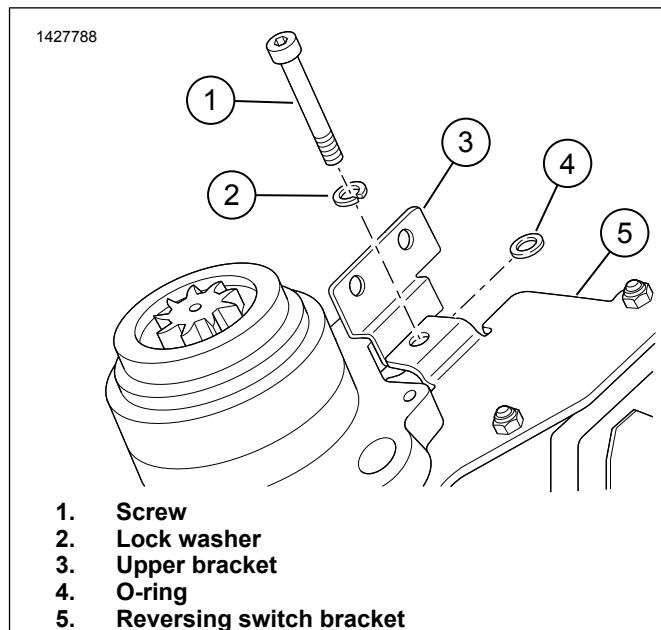


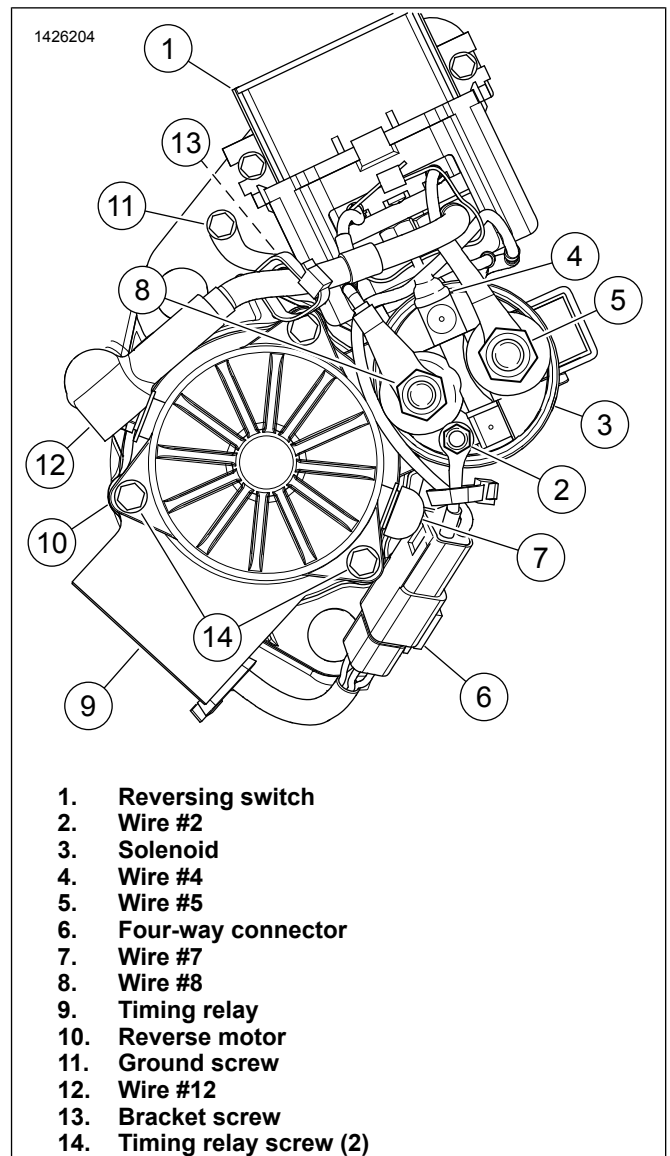
Figure 42. Contactor Z Upper Bracket

1. Screw
2. Lock washer
3. Upper bracket
4. O-ring
5. Reversing switch bracket

### Install Electrical Kit

1. See Figure 43. Install bracket screw (13). Tighten.  
Torque: 27–35 **in-lbs** (3–4 N·m) *Reversing switch bracket screw*
2. Attach wire #9 with ground screw (11). Tighten.  
Torque: 62–80 **in-lbs** (7–9 N·m) *Reversing switch ground screw*
3. Install timing relay.
  - a. Position timing relay (9) on reverse motor (10).
  - b. Install screws (14). Tighten.  
Torque: 35–53 **in-lbs** (4–6 N·m) *Reverse motor end cap screws*
  - c. Route wiring between reverse motor and solenoid.
  - d. Connect four-way connector (6).
  - e. Install wire #2 (2) on small solenoid stud.
  - f. Install nut. Tighten.  
Torque: 13–18 **in-lbs** (1.5–2 N·m) *Reverse motor solenoid wire 2 nut*
  - g. Install protective boot.
4. Install wire #4 (4) on solenoid.
  - a. Install wire #4 using screw. Tighten.  
Torque: 9–13 **in-lbs** (1–1.5 N·m) *Reverse motor solenoid screw*
  - b. Install **new** heat shrink over screw and terminal.

5. Connect reverse motor wires.
  - a. Install reversing switch wire #7 (7) to lower reverse motor stud.
  - b. Install nut. Tighten.  
Torque: 44–53 **in-lbs** (5–6 N·m) *Reverse motor wire #7 nut*
  - c. Install protective boot.
  - d. Install reversing switch wire #12 (12) to upper reverse motor stud.
  - e. Install nut. Tighten.  
Torque: 44–53 **in-lbs** (5–6 N·m) *Reverse motor wire #12 nut*
  - f. Install protective boot.
6. Install wires #8 and #5 on solenoid.
  - a. Install wire #8 (8) on lower solenoid post.
  - b. Install nut. Tighten.  
Torque: 44–53 **in-lbs** (5–6 N·m) *Reverse motor wire #8 nut*
  - c. Install protective boot.
  - d. Install wire #5 (5) on upper solenoid post.
  - e. Install nut finger tight.
7. Install contactor Z.
  - a. Position wire #11 at lower position on Contactor Z.
  - b. Install screw.
  - c. Position wire #1 at upper position on Contactor Z.
  - d. Install screw.
  - e. Tighten both screws.  
Torque: 13–18 **in-lbs** (1.5–2 N·m) *Contactor Z wire screws*
  - f. Install cover.
  - g. Install screws.
  - h. Install nut. Tighten screws.  
Torque: 9–13 **in-lbs** (1–1.5 N·m) *Contactor Z cover screws*
8. Install **new** cable strap to secure harness leads to each other.
9. Install **new** cable strap to secure harness leads to each other and reverse motor.



**Figure 43. Reverse Motor Electrical Kit Connections**

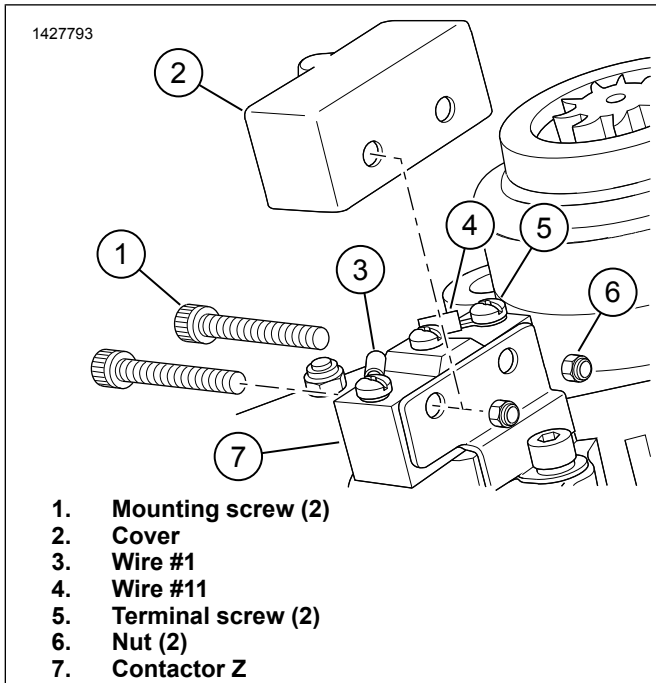


Figure 44. Contactor Z

## NEW LABOR CODE

Table 7. Labor Code

Item	Description	Time Code	Time
Replace reverse electronic control assembly, includes diagnosis.	Reverse operates but pinion does not retract.	1835	1.2 hours

## Supplemental Procedure Video

### ⚠ WARNING

Always review the appropriate service procedure prior to performing it. This video is intended to supplement, not replace, documented service procedures. Attempting service procedures without the proper training, tools, equipment, and manuals could result in death or injury to you or others. This could also damage the motorcycle or cause the motorcycle to operate improperly. (10406a)

This video is a supplement of the procedure covered in the document. This video can only be viewed through Service Information Portal (SIP).

1436457



Video 1. PINION EXTENDS BUT REVERSE MOTOR STALLS OR SPINS SLOWLY