



Technical Service Bulletin

SUBJECT:		No: TSB-25-42-001	
SUNROOF ASSEMBLY MAINTENANCE PROCEDURES DESCRIPTION CORRECTION – SERVICE MANUAL REVISION		DATE: January 2025	
		MODEL: Eclipse Cross	
CIRCULATE TO:	<input type="checkbox"/> GENERAL MANAGER	<input checked="" type="checkbox"/> PARTS MANAGER	<input checked="" type="checkbox"/> TECHNICIAN
<input checked="" type="checkbox"/> SERVICE ADVISOR	<input checked="" type="checkbox"/> SERVICE MANAGER	<input checked="" type="checkbox"/> WARRANTY PROCESSOR	<input type="checkbox"/> SALES MANAGER

PURPOSE

This TSB provides correction to the description of the Sunroof Assembly maintenance procedure in the applicable Service Manual sections:

- Body

AFFECTED VEHICLES

2018-2020 and 2022-2025 Eclipse Cross

AFFECTED SERVICE MANUAL

- 2018-2020 and 2022-2025 Eclipse Cross Service Manual

PROCEDURE

Please use the following chart (attached sheet 1) as a guide to replace the indicated pages in the affected Service Manuals, Group 42, Body, Power Panoramic Sunroof, Sunroof Assembly section.



Copyright 2025, Mitsubishi Motors North America, Inc.

The information contained in this bulletin is subject to change. For the latest version of this document, go to the Mitsubishi Dealer Link, MEDIC, or the Mitsubishi Service Information website (www.mitsubishitechinfo.com).

Applicable Manual	Pub. No.	Applicable Title	Contents
2018 ECLIPSE CROSS Service Manual	MSCD-020B-2018	BODY <ul style="list-style-type: none"> └ BODY └ POWER PANORAMIC SUNROOF └ SEALANT(S) OR ADHESIVE(S) 	Attached sheet 2
2019 ECLIPSE CROSS Service Manual	MSCD-020B-2019	BODY <ul style="list-style-type: none"> └ BODY └ POWER PANORAMIC SUNROOF └ SUNROOF ASSEMBLY └ REMOVAL AND INSTALLATION 	Attached sheet 3,4
2020 ECLIPSE CROSS Service Manual	MSCD-020B-2020	BODY <ul style="list-style-type: none"> └ BODY └ POWER PANORAMIC SUNROOF └ SUNROOF ASSEMBLY └ DISASSEMBLY AND REASSEMBLY 	Attached sheet 5
2022 ECLIPSE CROSS Service Manual	MSCD-020B-2022	BODY <ul style="list-style-type: none"> └ BODY └ POWER PANORAMIC SUNROOF └ SEALANT(S) OR ADHESIVE(S) 	Attached sheet 6
2023 ECLIPSE CROSS Service Manual	MSCD-020B-2023	BODY <ul style="list-style-type: none"> └ BODY └ POWER PANORAMIC SUNROOF └ SUNROOF ASSEMBLY └ REMOVAL AND INSTALLATION 	Attached sheet 7,8,9
2024 ECLIPSE CROSS Service Manual	MSCD-020B-2024	BODY <ul style="list-style-type: none"> └ BODY └ POWER PANORAMIC SUNROOF └ SUNROOF ASSEMBLY └ DISASSEMBLY AND REASSEMBLY 	Attached sheet 10
2025 ECLIPSE CROSS Service Manual	MSCD-020B-2025	BODY <ul style="list-style-type: none"> └ BODY └ POWER PANORAMIC SUNROOF └ SUNROOF ASSEMBLY └ DISASSEMBLY AND REASSEMBLY 	

POWER PANORAMIC SUNROOF

ADHESIVES

Item	Specified adhesive <Corrected>
Sunroof assembly	Primer: THE YOKOHAMA RUBBER CO., LTD. glass primer MS90 or equivalent
	Adhesive: THE YOKOHAMA RUBBER CO., LTD. urethane sealant WS-272 or equivalent
Rear fix glass panel assembly <Corrected>	Primer: THE YOKOHAMA RUBBER CO., LTD. glass primer PC-3, SIKA AG Primer 207 or equivalent <Corrected>
	Adhesive: THE YOKOHAMA RUBBER CO., LTD. urethane sealant WS-222, SIKA AG Flex 270 or equivalent <Corrected>

SUNROOF ASSEMBLY

REMOVAL AND INSTALLATION

Post-installation Operation

- Sunroof Alignment.
- Sunroof Leakage Check.
- Learning Procedures for Sunroof Fully Closed Position.

<Corrected>

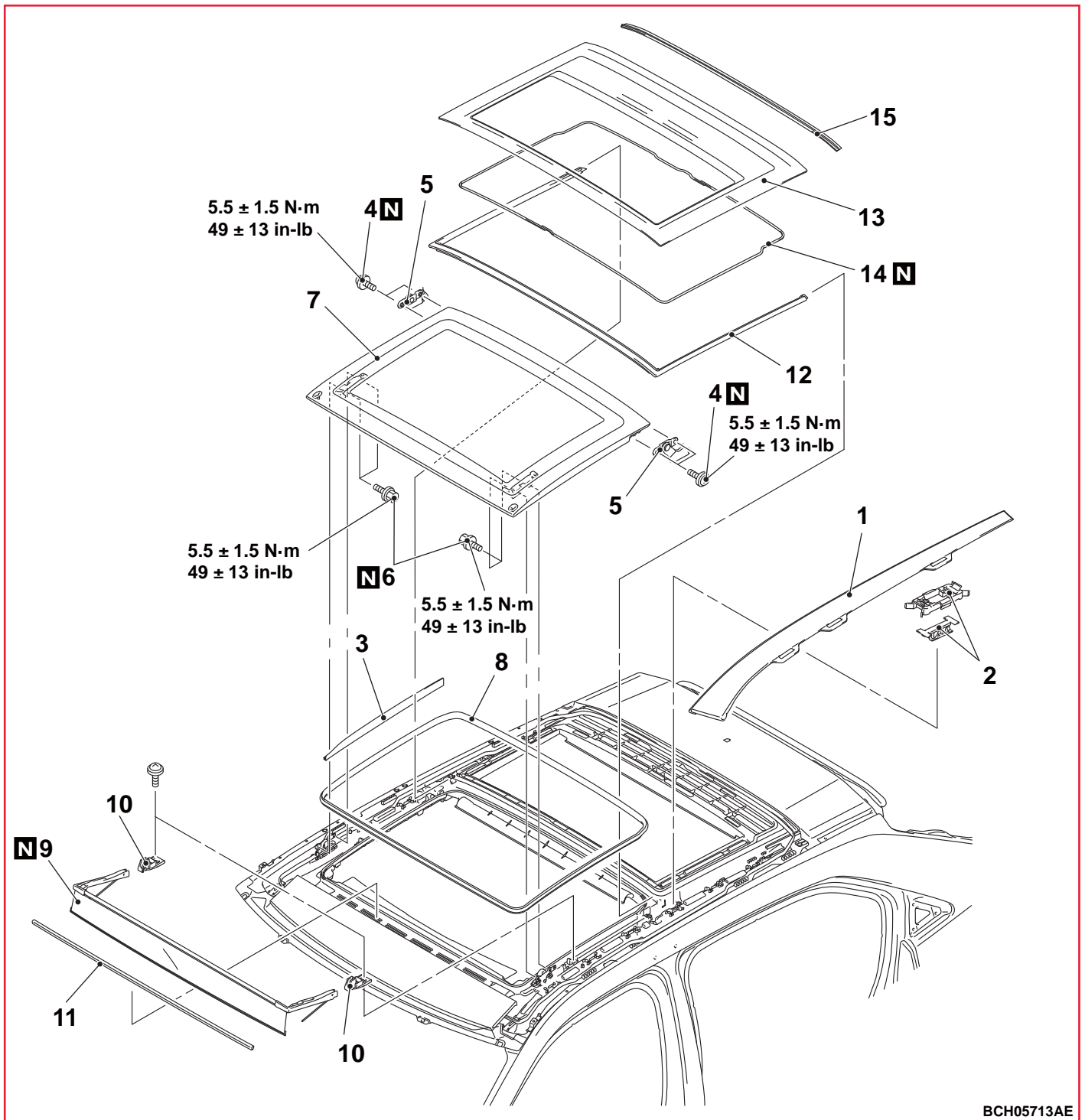

BCH05713AE

<Corrected>

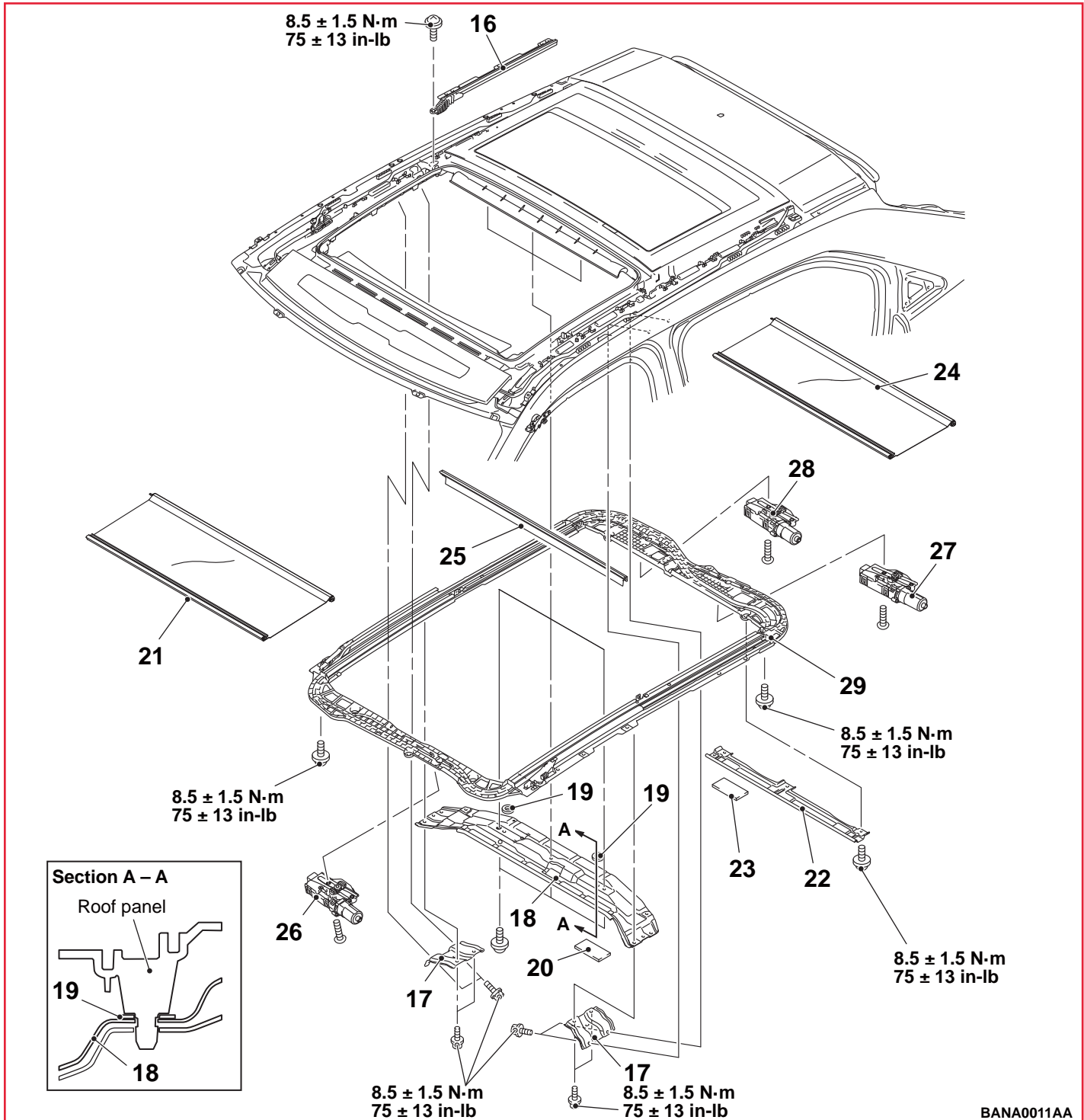

BANA0011AA

Roof side fin assembly/Side fin clip assembly removal steps

- Roof rack (Refer to GROUP 51, Roof Rack).
1. Roof side fin assembly
 2. Side fin clip assembly

Slide glass panel assembly/Slide weatherstrip removal steps

- Roof rack (Refer to GROUP 51, Roof Rack).

Slide glass panel assembly/Slide weatherstrip removal steps

4. Bolt
5. Rear link assembly
6. Bolt
7. Slide glass panel assembly
8. Slide glass panel weatherstrip

Deflector assembly removal

9. Deflector assembly

<<A>>

<<A>>

<>

	<p>Deflector fastener/Front fix weatherstrip removal steps</p> <ol style="list-style-type: none"> 10. Deflector fastener 11. Front fix weatherstrip <p>Rear fix weatherstrip removal steps</p> <ul style="list-style-type: none"> • Roof rack (Refer to GROUP 51, Roof Rack). 		<p>Shade screen removal steps</p> <ol style="list-style-type: none"> 19. Non-woven fabric 25. Shade screen <p>Front shade motor assembly removal steps</p> <ul style="list-style-type: none"> • Headlining (Refer to GROUP 52A, Headlining) • Front dome light bracket (Refer to GROUP 54A, Dome Light) 	
<<A>>	<ol style="list-style-type: none"> 1. Roof side fin assembly 3. Front inner blind 4. Bolt 5. Rear link assembly 6. Bolt 7. Slide glass panel assembly 12. Rear fix weatherstrip <p>Rear fix glass panel assembly removal steps</p>		<ol style="list-style-type: none"> 26. Front shade motor assembly 27. Sunroof motor assembly <p>Sunroof motor assembly removal steps</p> <ul style="list-style-type: none"> • Headlining (Refer to GROUP 52A, Headlining) 	
<<C>>	>>B<<	<ol style="list-style-type: none"> 13. Rear fix glass panel assembly 14. Seal tape 15. Molding <p>Outer rail removal steps</p> <ul style="list-style-type: none"> • Roof rack (Refer to GROUP 51, Roof Rack). 	<ul style="list-style-type: none"> • Headlining (Refer to GROUP 52A, Headlining) 	
<<A>>		<ol style="list-style-type: none"> 1. Roof side fin assembly 3. Front inner blind 4. Bolt 5. Rear link assembly 6. Bolt 7. Slide glass panel assembly 16. Outer rail <p>Center pillar bracket/Center pillar reinforcement removal steps</p> <ul style="list-style-type: none"> • Headlining (Refer to GROUP 52A, Headlining) 	<<A>>	<ol style="list-style-type: none"> 1. Roof side fin assembly 3. Front inner blind 4. Bolt 5. Rear link assembly 6. Bolt 7. Slide glass panel assembly 9. Deflector assembly 16. Outer rail <p>Mechanism assembly removal steps</p> <ul style="list-style-type: none"> • Roof rack (Refer to GROUP 51, Roof Rack).
	>>A<<	<ol style="list-style-type: none"> 17. Center pillar bracket 18. Center pillar reinforce assembly 19. Non-woven fabric 20. Roof clip <p>Clip bracket removal steps</p> <ul style="list-style-type: none"> • Headlining (Refer to GROUP 52A, Headlining) 	>>A<<	<ol style="list-style-type: none"> 17. Center pillar bracket 18. Center pillar reinforce assembly 19. Non-woven fabric 21. Front roll shade 22. Clip bracket assembly 24. Rear roll shade 25. Shade screen
<<D>>		<ol style="list-style-type: none"> 21. Front roll shade 22. Clip bracket assembly 23. Roof clip <p>Front roll shade removal steps</p> <ul style="list-style-type: none"> • Headlining (Refer to GROUP 52A, Headlining) 	<<D>>	<ul style="list-style-type: none"> • Front dome light bracket (Refer to GROUP 54A, Dome Light) • Connection connector
	>>A<<	<ol style="list-style-type: none"> 17. Center pillar bracket 18. Center pillar reinforce assembly 19. Non-woven fabric 	>>A<<	<ol style="list-style-type: none"> 26. Front shade motor assembly 27. Sunroof motor assembly 28. Rear shade motor assembly 29. Mechanism assembly
<<D>>		<ol style="list-style-type: none"> 21. Front roll shade <p>Rear roll shade removal steps</p> <ul style="list-style-type: none"> • Headlining (Refer to GROUP 52A, Headlining) 		
<<D>>		<ol style="list-style-type: none"> 22. Clip bracket assembly 24. Rear roll shade <p>Shade screen removal steps</p> <ul style="list-style-type: none"> • Headlining (Refer to GROUP 52A, Headlining) 		
	>>A<<	<ol style="list-style-type: none"> 17. Center pillar bracket 18. Center pillar reinforce assembly 	>>A<<	

POWER PANORAMIC SUNROOF

<> DEFLECTOR ASSEMBLY REMOVAL

⚠ CAUTION

Remove the deflector while holding it with your hand to prevent the deflector is rapidly coming off by its spring reaction.

1. Remove the tapping screw.

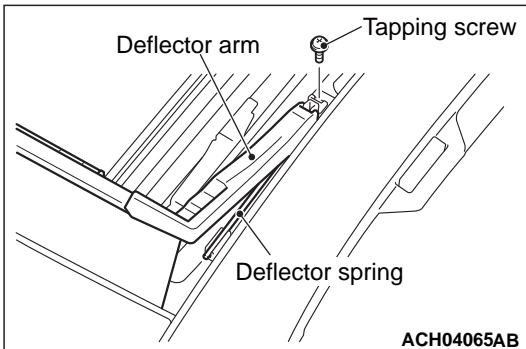

2. Remove the net of deflector from the housing using the special tool ornament remover (MB990784).

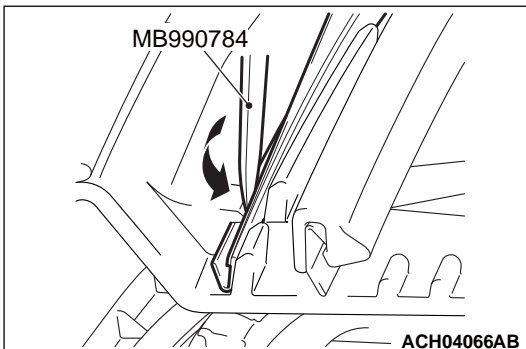
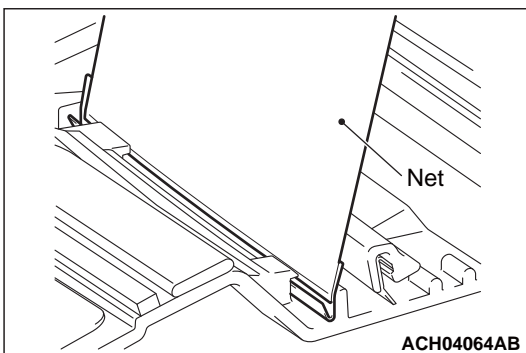

<Added>

<<C>> REAR FIX GLASS PANEL ASSEMBLY REMOVAL

Remove the rear fix glass panel assembly in the same way as the window shield.

<Added>

<<D>> FRONT ROLL SHADE/REAR ROLL SHADE REMOVAL

As the backlash occurs when removing the roll shade, pass a wire through the stopper hole to support the roll shade.

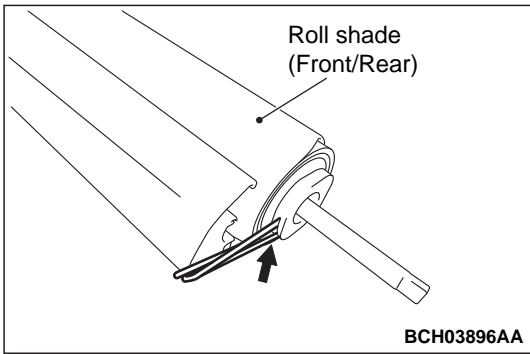

INSTALLATION SERVICE POINTS >>A<< CENTER PILLAR BRACKET INSTALLATION

1. Temporarily fix the center pillar bracket with the bolt (1) shown in the figure.
2. Tighten the roof side bolts (2) first, and then tighten the pillar side bolts (3).

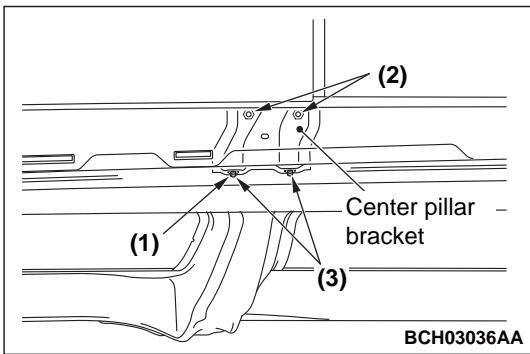

<Corrected>

<Corrected>

>>B<< REAR FIX GLASS PANEL ASSEMBLY INSTALLATION

⚠ CAUTION

Primers and adhesives from different manufacturers must not be used in combination. Be sure to use primers and adhesives from the same manufacturers in combination. The minimum drying time after adhering, etc., should be in accordance with the instructions of the respective adhesive manufacturer or instruction manuals.

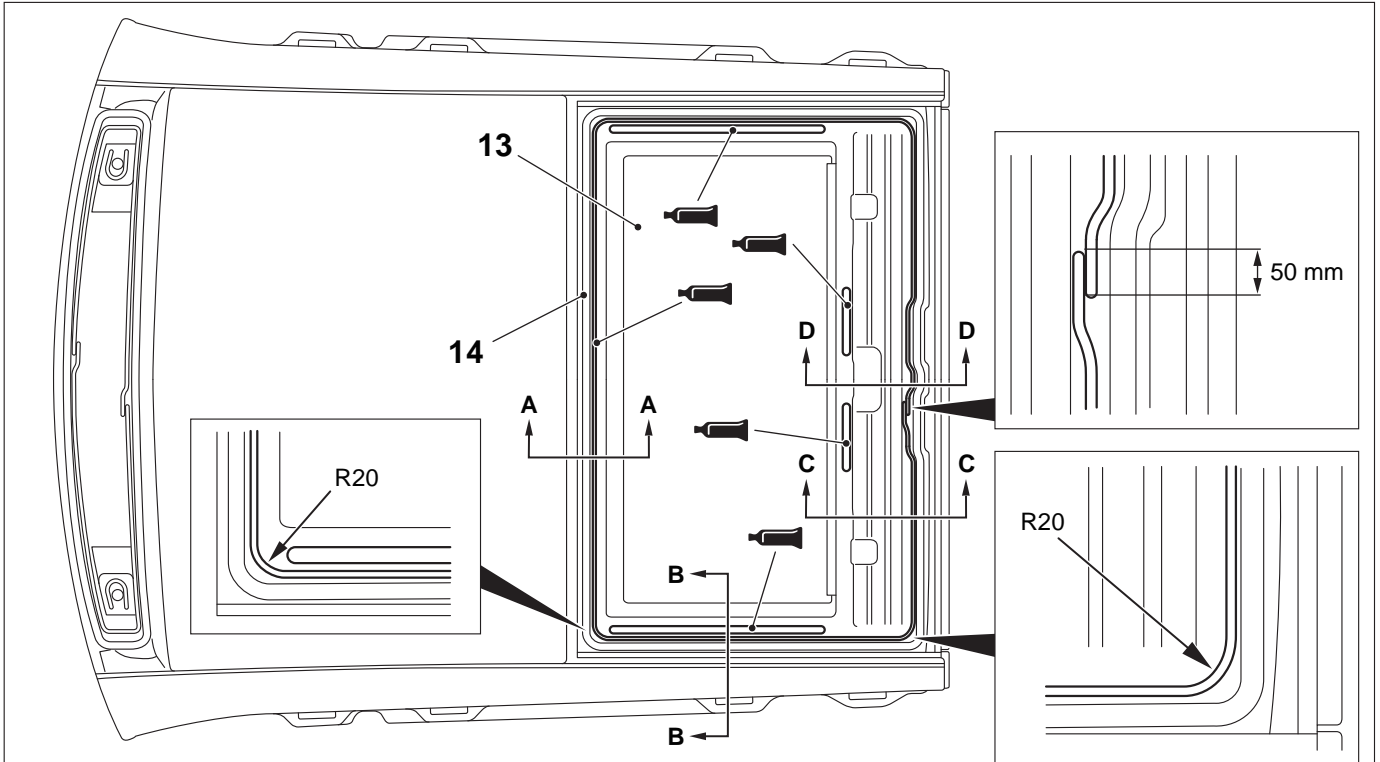

Section A – A

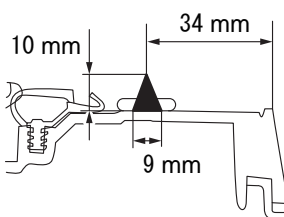

Section B – B

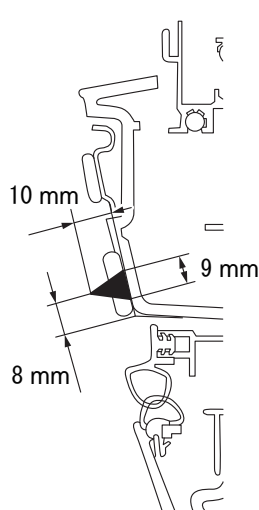

Section C – C

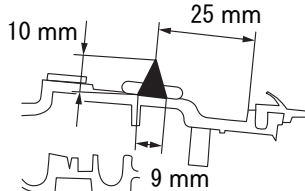

Section D – D

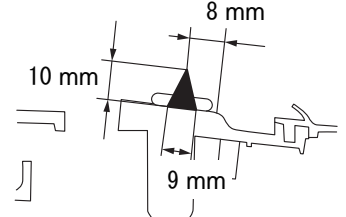

Primer: THE YOKOHAMA RUBBER CO., LTD. Glass primer PC-3, SIKA AG Primer 207 or equivalent
Adhesive: THE YOKOHAMA RUBBER CO., LTD. Urethane sealant WS-222, SIKA AG Flex 270 or equivalent

BANA0006AC

<Corrected>

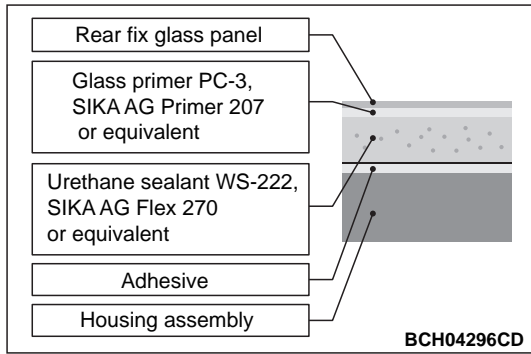

1. Degrease the adhesive surface of the rear fix glass panel assembly using IPA (Isopropyl alcohol).
2. Apply THE YOKOHAMA RUBBER CO., LTD. Glass primer PC-3, SIKA AG Primer 207 or equivalent to the rear fix glass assembly.
3. Approximately 3 minutes after applying the primer (reapplication is necessary if left for 8 hours or more), apply THE YOKOHAMA RUBBER CO., LTD. Urethane sealant WS-222, SIKA AG Flex 270 or equivalent to the adhesive surface of the sunroof housing assembly and install the rear fix glass panel assembly to the sunroof housing assembly.

<Corrected>

DISASSEMBLY AND REASSEMBLY

<Mechanism assembly>

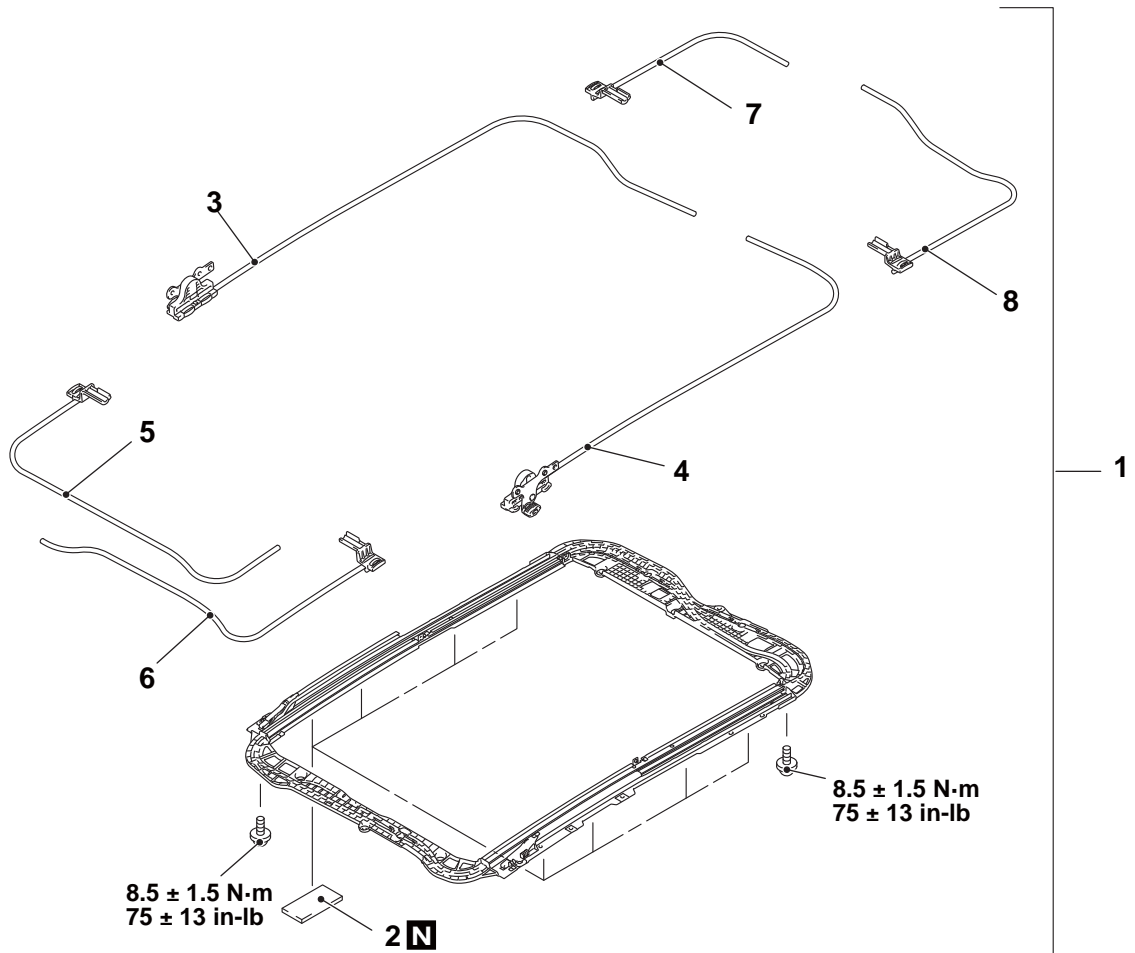

BCH05733AB

Disassembly steps

1. Mechanism assembly
2. Fastener
3. Slide glass guide (RH)
4. Slide glass guide (LH)

Disassembly steps

5. Front shade cable (RH)
6. Front shade cable (LH)
7. Rear shade cable (RH)
8. Rear shade cable (LH)

<Corrected>

CAUTION

Primers and adhesives from different manufacturers must not be used in combination. Be sure to use primers and adhesives from the same manufacturers in combination. The minimum drying time after adhering, etc., should be in accordance with the instructions of the respective adhesive manufacturer or instruction manuals.

<Glass housing assembly>

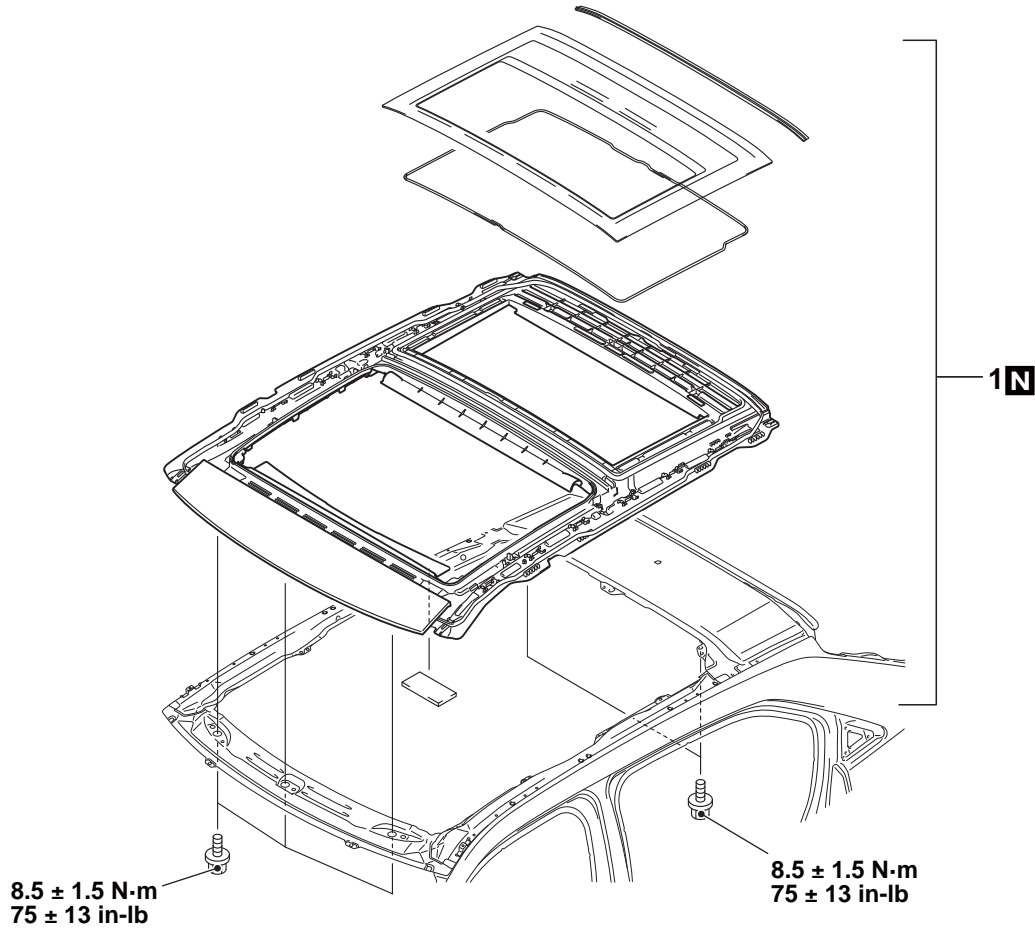

BCH05744AH

<Deleted>

<Corrected>

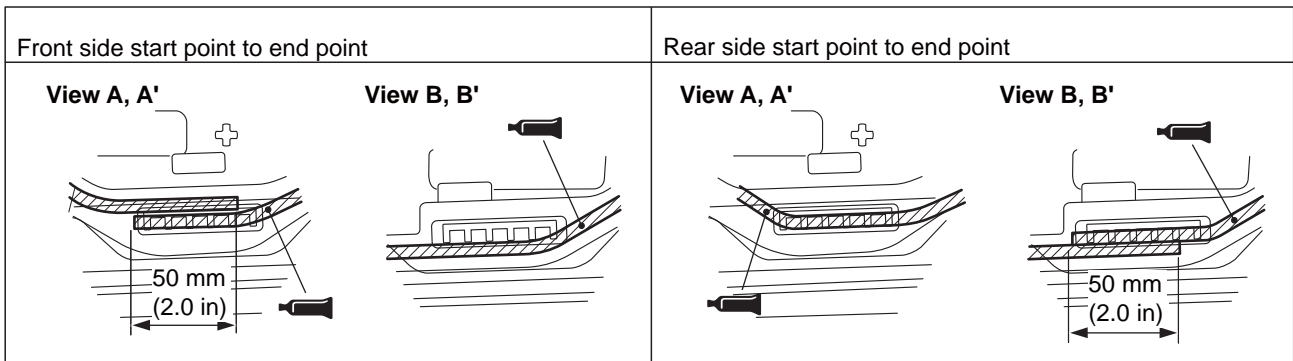
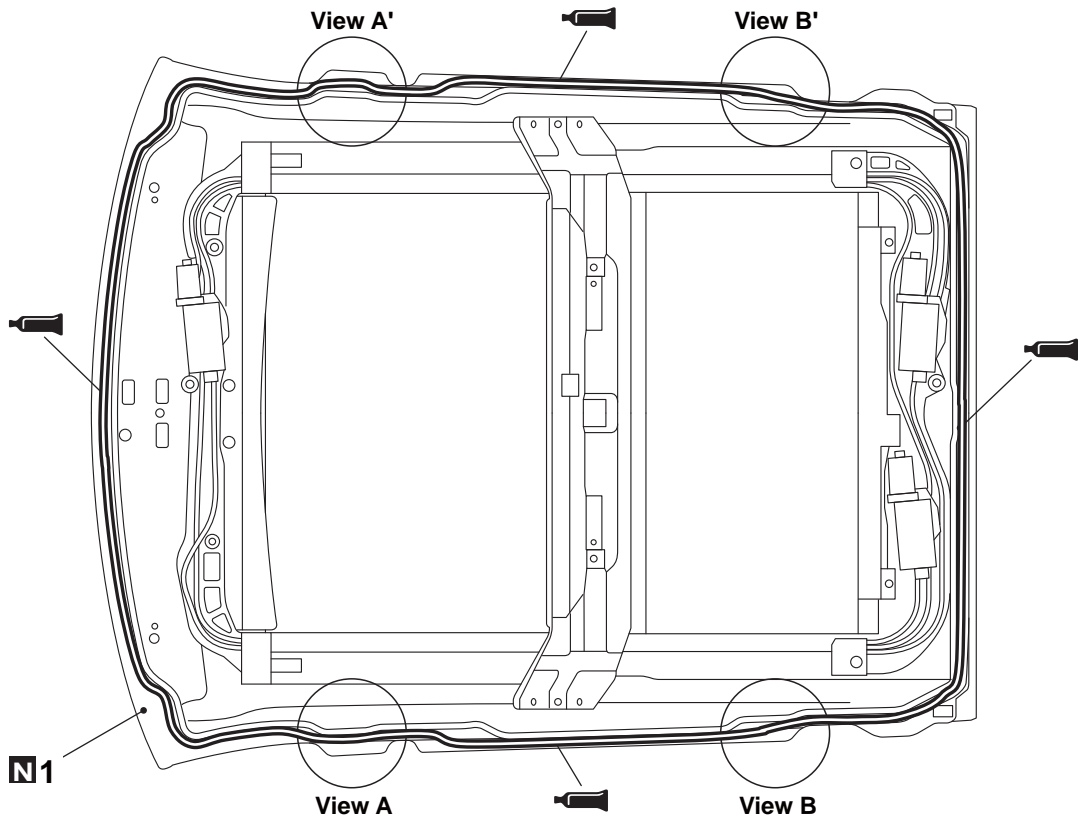

Primer: THE YOKOHAMA RUBBER CO., LTD. glass primer MS90 or equivalent
Adhesive: THE YOKOHAMA RUBBER CO., LTD. urethane sealant WS-272 or equivalent

BCH04421AC

**Glass housing assembly
disassembly**

<<A>> >>A<< 1. Glass housing assembly

DISASSEMBLY SERVICE POINTS

<<A>> GLASS HOUSING ASSEMBLY REMOVAL

Remove the glass housing assembly in the same way as the window shield.

REASSEMBLY SERVICE POINTS

>>A<< HOUSING ASSEMBLY INSTALLATION

1. Degrease the adhesive surface of the sunroof housing assembly using IPA (Isopropyl alcohol).

**BODY
POWER PANORAMIC SUNROOF**

<Corrected>

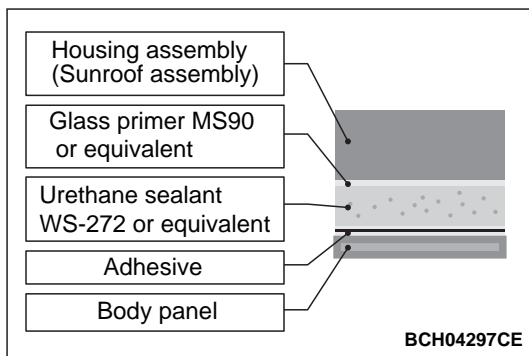

2. Apply THE YOKOHAMA RUBBER CO., LTD. Glass primer MS90 or equivalent to the sunroof housing assembly.
3. Approximately 3 minutes after applying the primer (reapplication is necessary if left for 8 hours or more), apply THE YOKOHAMA RUBBER CO., LTD. Urethane sealant WS-272 or equivalent to the adhesive surface of the sunroof housing assembly and install the sunroof housing assembly to the body panel.

POWER PANORAMIC SUNROOF

ADHESIVES

Item	Specified adhesive
Sunroof assembly	Primer: THE YOKOHAMA RUBBER CO., LTD. glass primer MS90 or equivalent
	Adhesive: THE YOKOHAMA RUBBER CO., LTD. urethane sealant WS-272 or equivalent
<div style="border: 1px solid red; padding: 2px;">Rear fix glass panel assembly</div> <Corrected>	Primer: THE YOKOHAMA RUBBER CO., LTD. glass primer PC-3 SIKA AG Primer 207 or equivalent <Added>
	Adhesive: THE YOKOHAMA RUBBER CO., LTD. urethane sealant WS-222 SIKA AG Flex 270 or equivalent <Added>

SUNROOF ASSEMBLY

REMOVAL AND INSTALLATION

Post-installation Operation

- Sunroof Alignment.
- Sunroof Leakage Check.
- Learning Procedures for Sunroof Fully Closed Position.

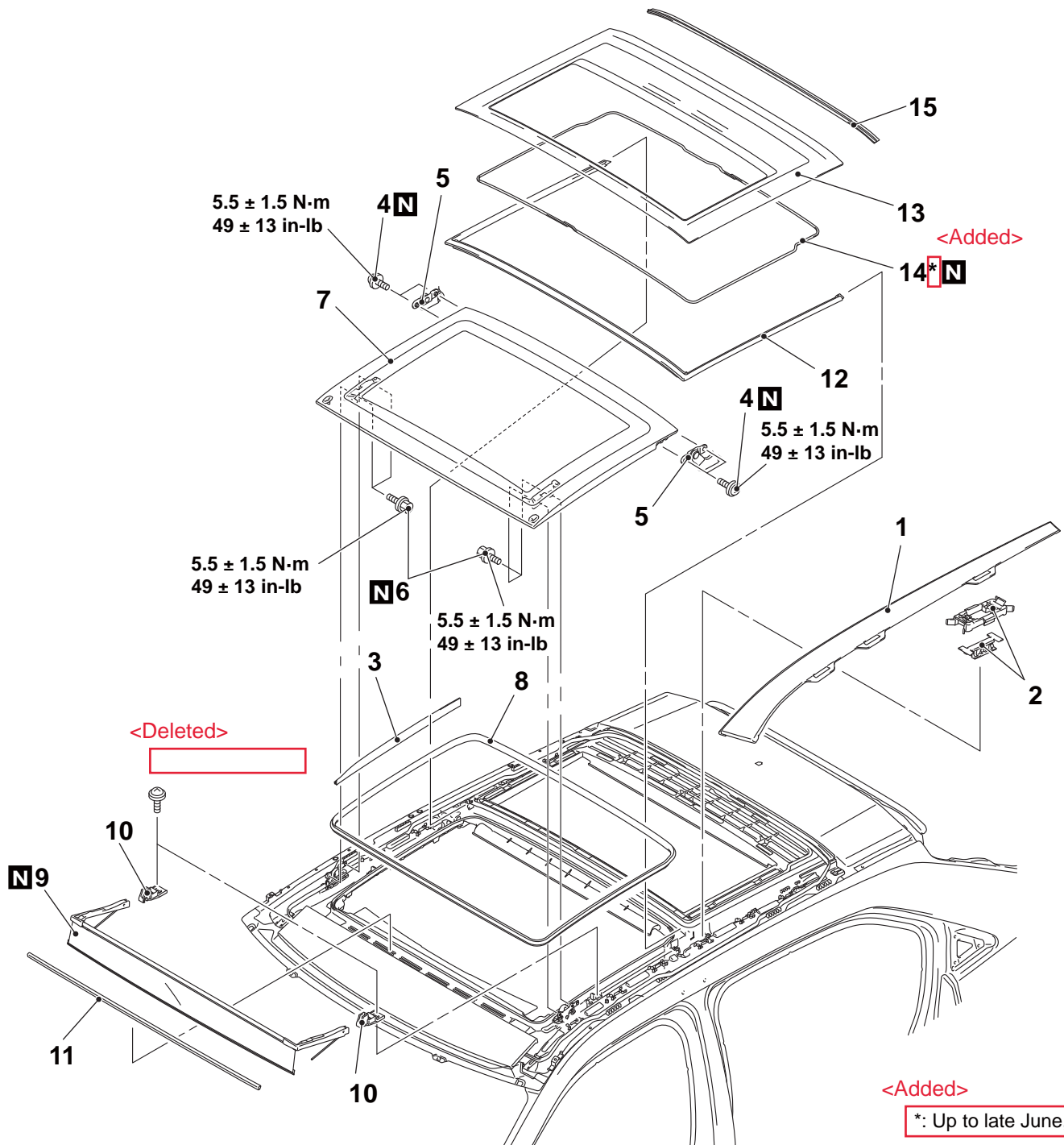

BCH05713AG

<Corrected>

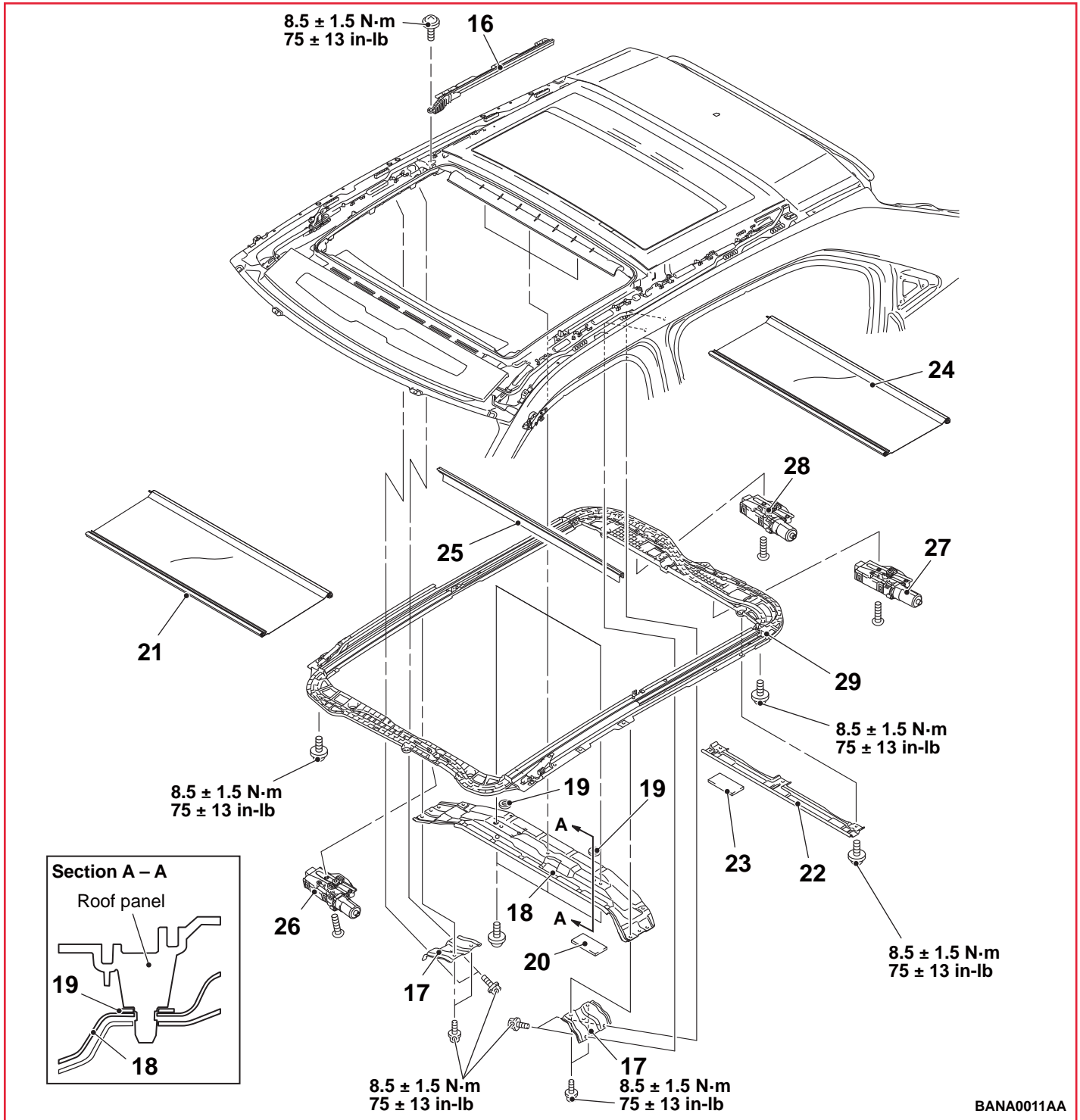

Roof side fin assembly/Side fin clip assembly removal steps

- <<A>>
- Roof rack (Refer to GROUP 51, Roof Rack).
 - 1. Roof side fin assembly
 - 2. Side fin clip assembly

Slide glass panel assembly/Slide weatherstrip removal steps

- <<A>>
- Roof rack (Refer to GROUP 51, Roof Rack).
 - 1. Roof side fin assembly
 - 3. Front inner blind

Slide glass panel assembly/Slide weatherstrip removal steps

- <>
- 4. Bolt
 - 5. Rear link assembly
 - 6. Bolt
 - 7. Slide glass panel assembly
 - 8. Slide glass panel weatherstrip
 - 9. Deflector assembly

POWER PANORAMIC SUNROOF

	<p>Deflector fastener/Front fix weatherstrip removal steps</p> <ol style="list-style-type: none"> 10. Deflector fastener 11. Front fix weatherstrip <p>Rear fix weatherstrip removal steps</p> <ul style="list-style-type: none"> • Roof rack (Refer to GROUP 51, Roof Rack). 				
<<A>>	<ol style="list-style-type: none"> 1. Roof side fin assembly 3. Front inner blind 4. Bolt 5. Rear link assembly 6. Bolt 7. Slide glass panel assembly 12. Rear fix weatherstrip <p>Rear fix glass panel assembly removal steps</p>				
<<C>>	>>B<<	<ol style="list-style-type: none"> 13. Rear fix glass panel assembly 14. Seal tape 15. Molding <p>Outer rail removal steps</p> <ul style="list-style-type: none"> • Roof rack (Refer to GROUP 51, Roof Rack). 			
<<A>>		<ol style="list-style-type: none"> 1. Roof side fin assembly 3. Front inner blind 4. Bolt 5. Rear link assembly 6. Bolt 7. Slide glass panel assembly 16. Outer rail 	<<A>>		
<Corrected>		<p>Center pillar bracket/Center pillar reinforcement removal steps</p> <ul style="list-style-type: none"> • Headlining (Refer to GROUP 52A, Headlining) 	<>		
	>>A<<	<ol style="list-style-type: none"> 17. Center pillar bracket 18. Center pillar reinforce assembly 19. Non-woven fabric 20. Roof clip <p>Clip bracket removal steps</p> <ul style="list-style-type: none"> • Headlining (Refer to GROUP 52A, Headlining) 	>>A<<		
<<D>>		<ol style="list-style-type: none"> 21. Front roll shade 22. Clip bracket assembly 23. Roof clip <p>Front roll shade removal steps</p> <ul style="list-style-type: none"> • Headlining (Refer to GROUP 52A, Headlining) 	<<D>>		
	>>A<<	<ol style="list-style-type: none"> 17. Center pillar bracket 18. Center pillar reinforce assembly 19. Non-woven fabric 			
<<D>>		<ol style="list-style-type: none"> 21. Front roll shade <p>Rear roll shade removal steps</p> <ul style="list-style-type: none"> • Headlining (Refer to GROUP 52A, Headlining) 			
<<D>>		<ol style="list-style-type: none"> 22. Clip bracket assembly 24. Rear roll shade <p>Shade screen removal steps</p> <ul style="list-style-type: none"> • Headlining (Refer to GROUP 52A, Headlining) 			
	>>A<<	<ol style="list-style-type: none"> 17. Center pillar bracket 18. Center pillar reinforce assembly 			
		<p>Shade screen removal steps</p> <ol style="list-style-type: none"> 19. Non-woven fabric 25. Shade screen <p>Front shade motor assembly removal steps</p> <ul style="list-style-type: none"> • Headlining (Refer to GROUP 52A, Headlining) • Front dome light bracket (Refer to GROUP 54A, Dome Light) 			
		<ol style="list-style-type: none"> 26. Front shade motor assembly <p>Sunroof motor assembly removal steps</p> <ul style="list-style-type: none"> • Headlining (Refer to GROUP 52A, Headlining) 			
		<ol style="list-style-type: none"> 27. Sunroof motor assembly <p>Rear shade motor assembly removal steps</p> <ul style="list-style-type: none"> • Headlining (Refer to GROUP 52A, Headlining) 			
		<ol style="list-style-type: none"> 28. Rear shade motor assembly <p>Mechanism assembly removal steps</p> <ul style="list-style-type: none"> • Roof rack (Refer to GROUP 51, Roof Rack). 			
		<ol style="list-style-type: none"> 1. Roof side fin assembly 3. Front inner blind 4. Bolt 5. Rear link assembly 6. Bolt 7. Slide glass panel assembly 9. Deflector assembly 16. Outer rail <ul style="list-style-type: none"> • Headlining (Refer to GROUP 52A, Headlining) 			
		<ol style="list-style-type: none"> 17. Center pillar bracket 18. Center pillar reinforce assembly 19. Non-woven fabric 21. Front roll shade 22. Clip bracket assembly 24. Rear roll shade 25. Shade screen <ul style="list-style-type: none"> • Front dome light bracket (Refer to GROUP 54A, Dome Light) • Connection connector 			
		<ol style="list-style-type: none"> 26. Front shade motor assembly • Connection connector 27. Sunroof motor assembly 28. Rear shade motor assembly 29. Mechanism assembly 			

<Corrected>

>>B<< REAR FIX GLASS PANEL ASSEMBLY INSTALLATION

⚠ CAUTION

Primers and adhesives from different manufacturers must not be used in combination. Be sure to use primers and adhesives from the same manufacturers in combination. The minimum drying time after adhering, etc., should be in accordance with the instructions of the respective adhesive manufacturer or instruction manuals.

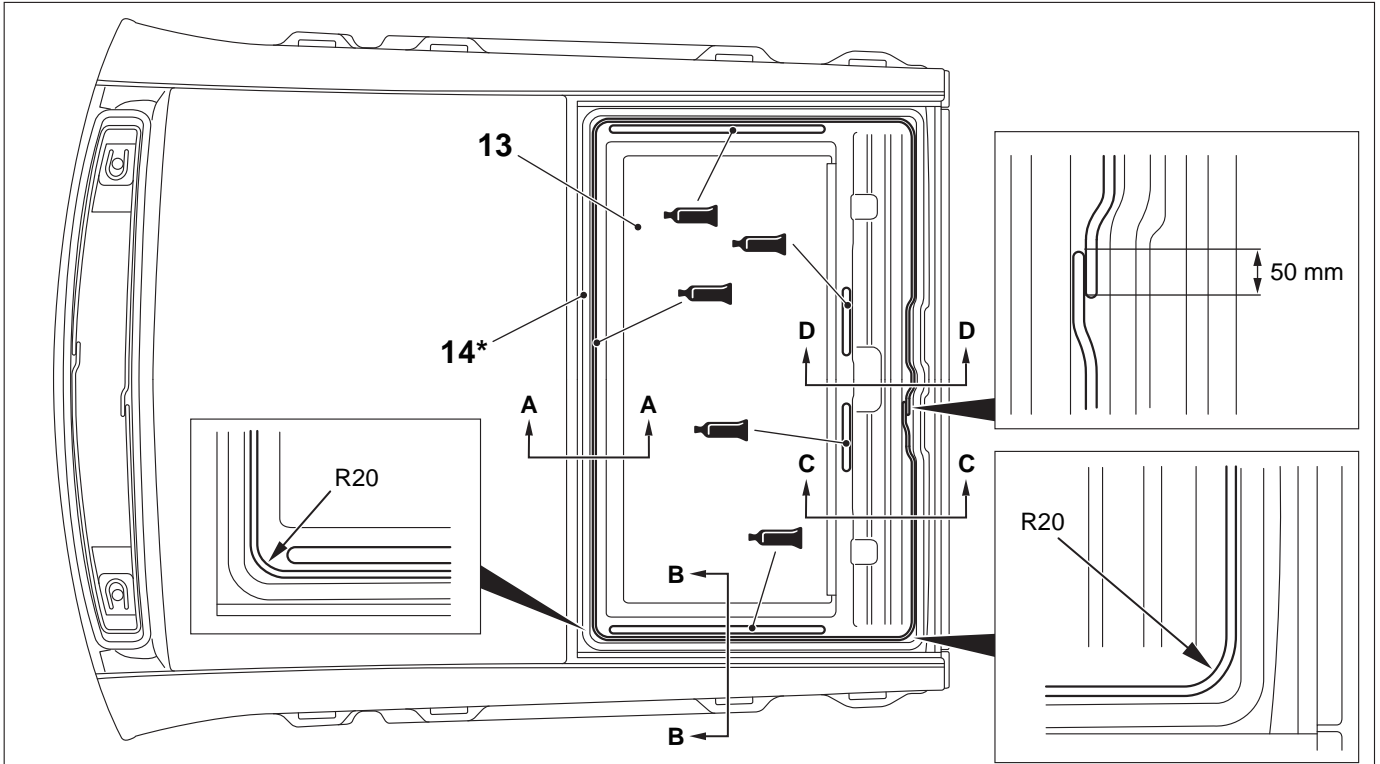

*: Up to late June, 2022

Section A – A

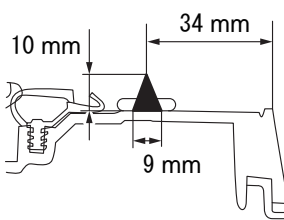

Section B – B

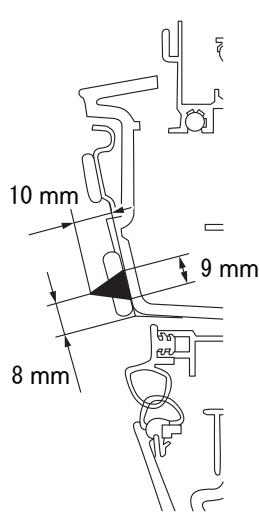

Section C – C

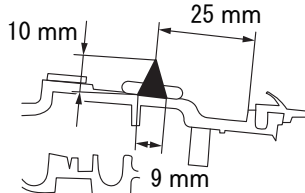

Section D – D

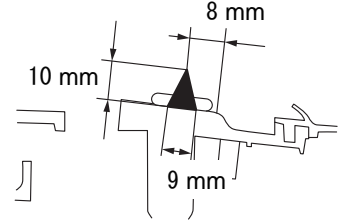

Primer: THE YOKOHAMA RUBBER CO., LTD. Glass primer PC-3, SIKA AG Primer 207 or equivalent
Adhesive: THE YOKOHAMA RUBBER CO., LTD. Urethane sealant WS-222, SIKA AG Flex 270 or equivalent

BANA0006AC

<Corrected>

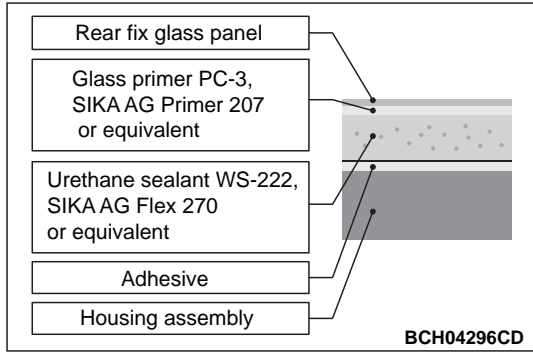

1. Degrease the adhesive surface of the rear fix glass panel assembly using IPA (Isopropyl alcohol).
2. Apply THE YOKOHAMA RUBBER CO., LTD. Glass primer PC-3, SIKA AG Primer 207 or equivalent to the rear fix glass assembly.
3. Approximately 3 minutes after applying the primer (reapplication is necessary if left for 8 hours or more), apply THE YOKOHAMA RUBBER CO., LTD. Urethane sealant WS-222, SIKA AG Flex 270 or equivalent to the adhesive surface of the sunroof housing assembly and install the rear fix glass panel assembly to the sunroof housing assembly.

<Added>

CAUTION

Primers and adhesives from different manufacturers must not be used in combination. Be sure to use primers and adhesives from the same manufacturers in combination. The minimum drying time after adhering, etc., should be in accordance with the instructions of the respective adhesive manufacturer or instruction manuals.

<Glass housing assembly>

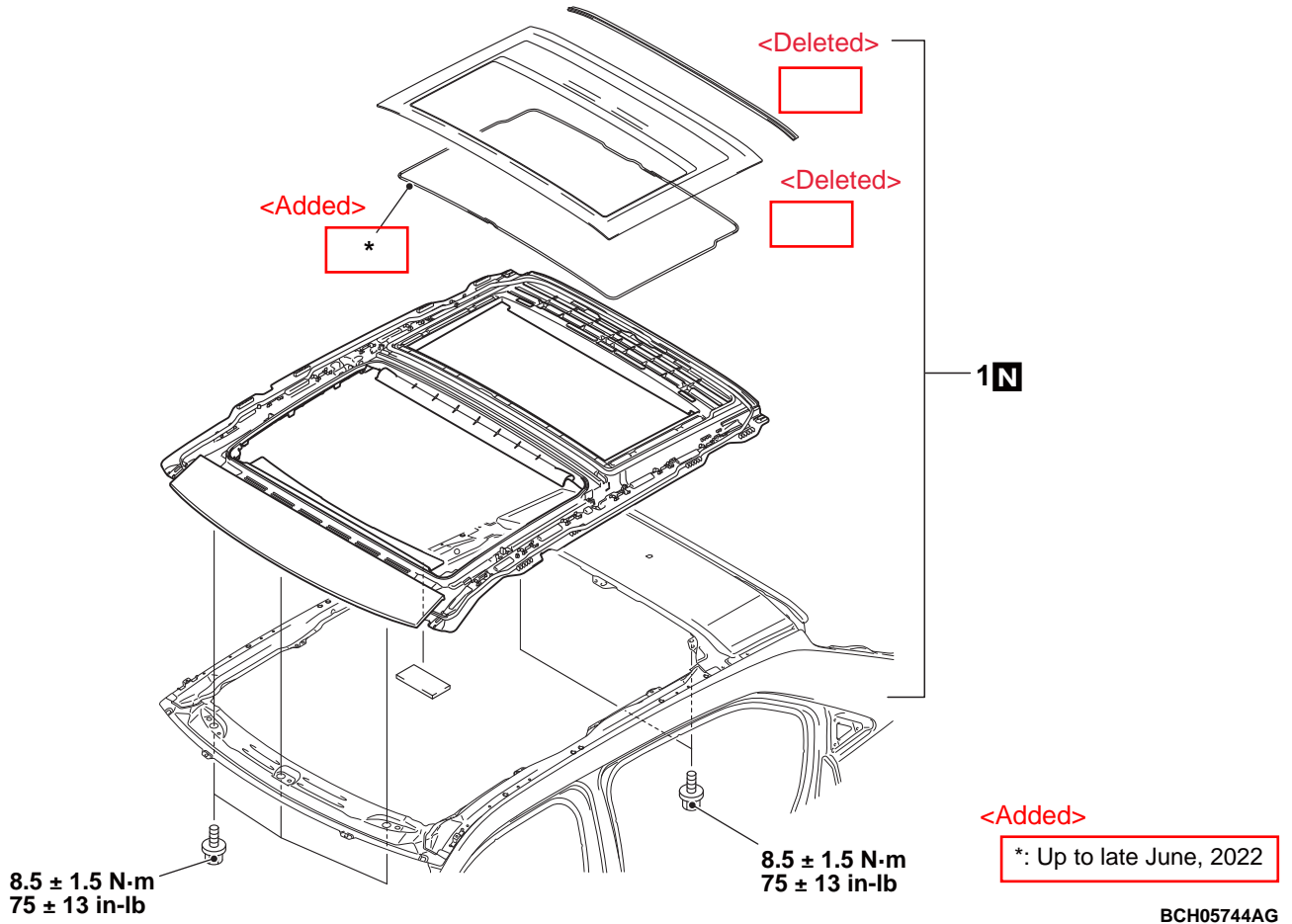

<Deleted>

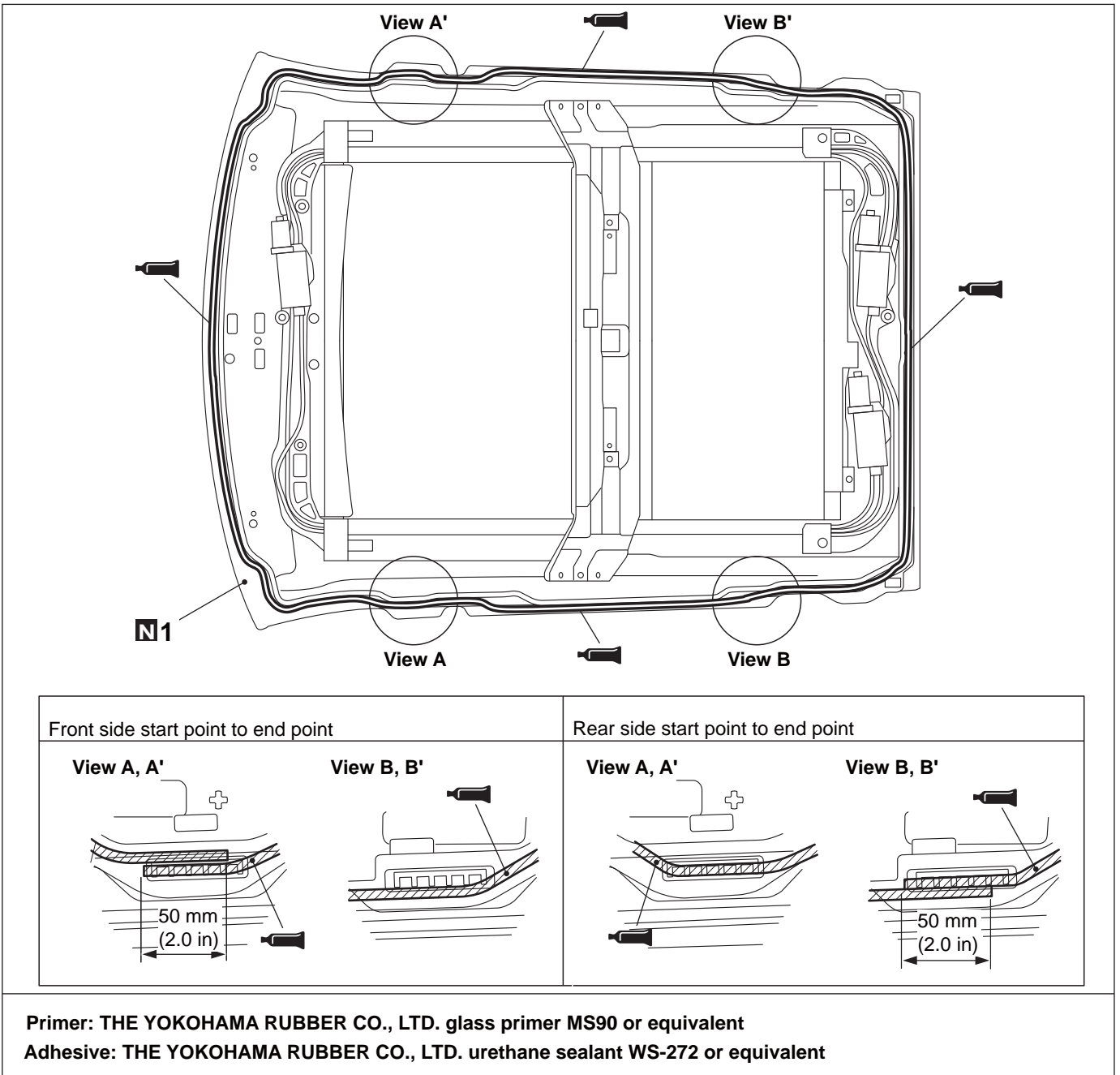

BCH04421AC

- <Corrected>
 <<A>> >>A<<
- Glass housing assembly disassembly**
1. Glass housing assembly

<Deleted>

DISASSEMBLY SERVICE POINTS

<<A>> GLASS HOUSING ASSEMBLY REMOVAL

Remove the glass housing assembly in the same way as the window shield.

<Deleted>

REASSEMBLY SERVICE POINTS

<Deleted>

<Corrected>

>>A<< HOUSING ASSEMBLY INSTALLATION

1. Degrease the adhesive surface of the sunroof housing assembly using IPA (Isopropyl alcohol).

<Corrected>

BODY
POWER PANORAMIC SUNROOF

Attached sheet 10 (3/3)

<Corrected>

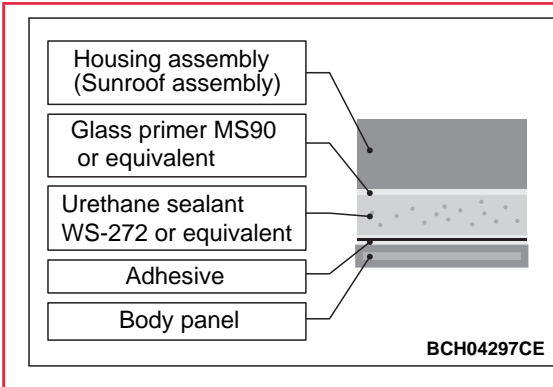

2. Apply THE YOKOHAMA RUBBER CO., LTD. Glass primer MS90 or equivalent to the sunroof housing assembly.
3. Approximately 3 minutes after applying the primer (reapplication is necessary if left for 8 hours or more), apply THE YOKOHAMA RUBBER CO., LTD. Urethane sealant WS-272 or equivalent to the adhesive surface of the sunroof housing assembly and install the sunroof housing assembly to the body panel.