

"DOCUMENT UNCONTROLLED IF PRINTED"

DOC #	PROCESS NAME	PAGE	REVISION	STATION	BY	DATE
AR882	SOE Compressor Mounting Bracket Gusset Installation	1	-	E	SB	4/6/21

Read process before beginning. If you do not understand any part please contact: Brad Fisher, Service Manager at 1-866-953-5555 or by e-mail at bfisher@ARBOCsv.com

Good Mechanics safety practice must be followed on any repairs.

Safety practices should include but not be limited to properly supporting the chassis, axles, blocking tires, and a work area free of clutter.

Repair shops safety rules must be followed and safety equipment used. O.E.M. Battery and Auxiliary Battery **MUST** be disconnected.

Complaint: Compressor mounting brackets are breaking

Cause : Design

Correction: Add gusset to compressor mounting bracket

Vehicles Affected: Spirit of Equess (SOE) buses

Labor Op code : 0128905

Labor Time Allowance : 1.0

Parts Return : No

Pre Auth Required: Yes

Tools Required:

3/8" or 7/16" Drill Bit

9/16" Wrench

9/16" Socket Wrench capable of torque to 44ft-lbs. May need 6" extension.

Parts Required :

Qty of 1	Existing compressor bracket
Qty of 1	1314692-BRACKET, ALTERNATOR RETROFIT GUSSET 8" X 4-3/4" (EQUESS) BLACK
Qty of 4	2005527-NUT, 3/8-16 GR. ZINC FINISH FLANGE HEX NUT
Qty of 2	616156-SCREW, CAP - 3/8X1-1/4 PERMA PLATED TUF-TORQ #633
Qty of 2	616159-SCREW, CAP - 3/8X2 PERMA PLATED TUF-TORQ #636
Qty of 2	721951-WASHER, FRP 3/8" ALLOY L/WSH

Repair Instruction

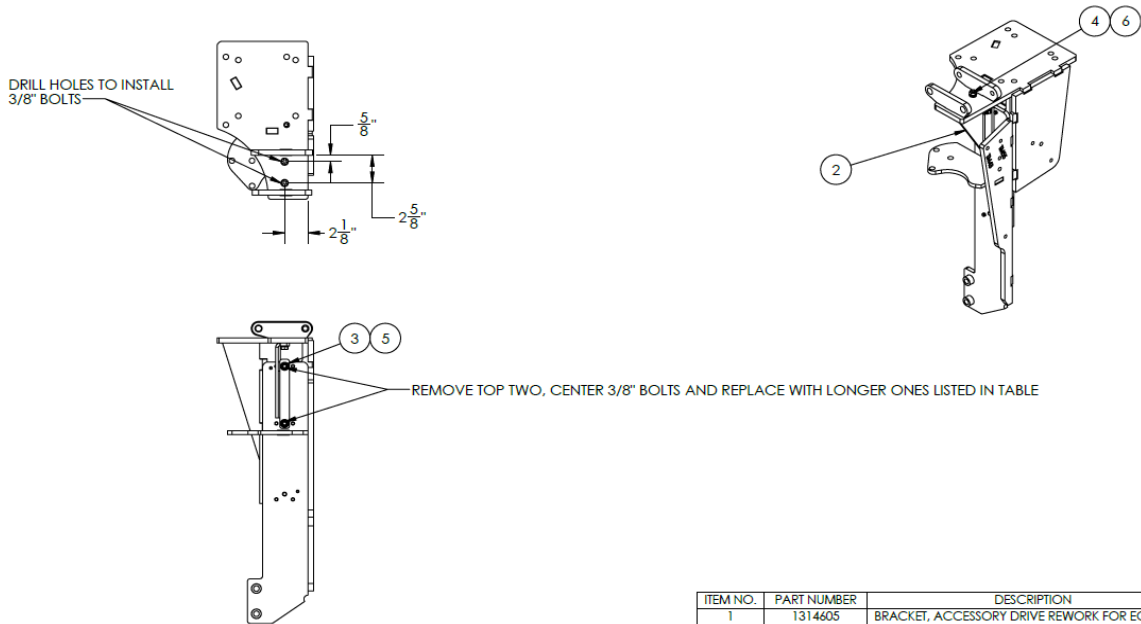

ITEM NO.	PART NUMBER	DESCRIPTION	QTY.
1	1314605	BRACKET, ACCESSORY DRIVE REWORK FOR EQUESS TD	1
2	1314692	GUSSET, RETROFIT FOR OLD ALTERNATOR BRACKET, SOE	1
3	2005527	NUT, 3/8-16 GR. ZINC FINISH FLANGE HEX NUT	4
4	616156	SCREW, CAP - 3/8X1-1/4 PERMA PLATED TUR-TORQ #633	2
5	616159	SCREW, CAP - 3/8 X 2 PERMA PLATED TUF-TORQ #636	2
6	721951	WASHER, FRP 3/8" ALLOY L/WSH	2

Dry install torque 3/8" nuts to 44 ft-lbs.