

Technical Service Bulletin

Mazda North American Operations
Irvine, CA 92618-2922



Subject: CUP HOLDER LID DOES NOT OPEN/CLOSE	Bulletin No.: 09-008/25
	Last Issued : 01/30/2025

BULLETIN NOTES

This bulletin supersedes the previously issued bulletin(s) listed below. The changes are noted in Red.

Previous TSBs:	Date(s) Issued:
09-011/24	02/12/24

APPLICABLE MODEL(S)/VINS

2024-2025 CX-90

2025 CX-70

DESCRIPTION

Some customers may complain that the cup holder lid does not open/close. This malfunction is caused by a fracture of the cup holder lid's lock pin due to excessive force applied on the lid.

Customers having this concern should have their vehicle repaired using the following repair procedure.

REPAIR PROCEDURE

1. Verify the customer concern.
2. Access the lock pin.
3. Remove the shift panel according to the workshop manual (SHIFT PANEL REMOVAL/INSTALLATION).

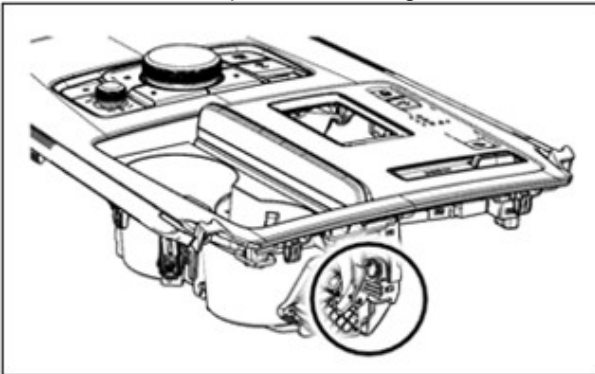

NOTE:

- Leave the cup holder lid open.
- DO NOT wipe off the grease on the lock pin installation site.

CONSUMER NOTICE: The information and instructions in this bulletin are intended for use by skilled technicians. Mazda technicians utilize the proper tools/ equipment and take training to correctly and safely maintain Mazda vehicles. These instructions should not be performed by "do-it-yourselfers." Customers should not assume this bulletin applies to their vehicle or that their vehicle will develop the described concern. To determine if the information applies, customers should contact their nearest authorized Mazda dealership. Mazda North American Operations reserves the right to alter the specifications and contents of this bulletin without obligation or advance notice. All rights reserved. No part of this bulletin may be reproduced in any form or by any means, electronic or mechanical--including photocopying and recording and the use of any kind of information storage and retrieval system ---without permission in writing.

4. Unlock the clip (1) and rotate the lock pin (2).

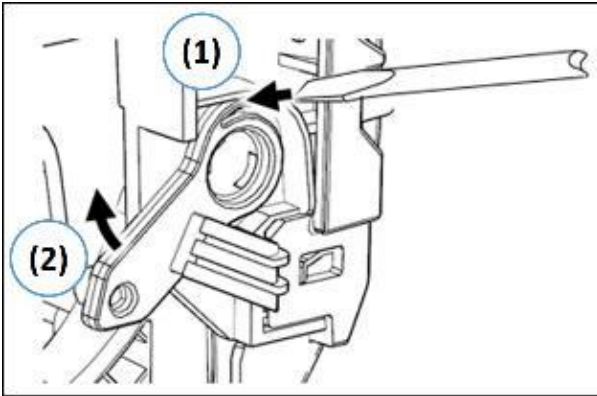

5. Remove the lock pin inserting a slotted screwdriver (1).

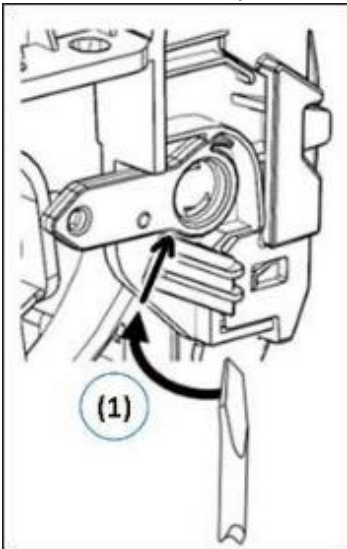

CONSUMER NOTICE: The information and instructions in this bulletin are intended for use by skilled technicians. Mazda technicians utilize the proper tools/ equipment and take training to correctly and safely maintain Mazda vehicles. These instructions should not be performed by "do-it-yourselfers." Customers should not assume this bulletin applies to their vehicle or that their vehicle will develop the described concern. To determine if the information applies, customers should contact their nearest authorized Mazda dealership. Mazda North American Operations reserves the right to alter the specifications and contents of this bulletin without obligation or advance notice. All rights reserved. No part of this bulletin may be reproduced in any form or by any means, electronic or mechanical---including photocopying and recording and the use of any kind of information storage and retrieval system ---without permission in writing.

6. Remove the washer from the lock pin.
NOTE: Keep the washer for the next step.

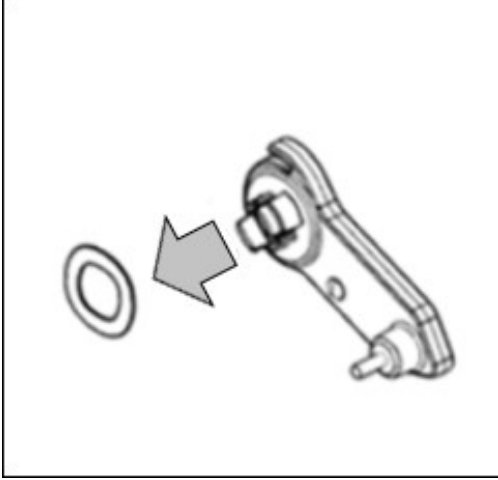

7. Install the washer on the new lock pin.

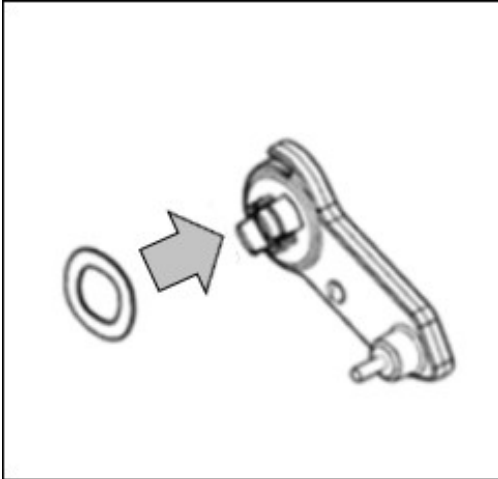

8. Install in the reverse order of removal.
 9. Verify the repair.

NOTE: Inform the customer to try not to put too much weight on the center console lid.

PARTS INFORMATION

Parts Number	Description	Qty.
KBB4-64-354	PIN	1

CONSUMER NOTICE: The information and instructions in this bulletin are intended for use by skilled technicians. Mazda technicians utilize the proper tools/ equipment and take training to correctly and safely maintain Mazda vehicles. These instructions should not be performed by "do-it-yourselfers." Customers should not assume this bulletin applies to their vehicle or that their vehicle will develop the described concern. To determine if the information applies, customers should contact their nearest authorized Mazda dealership. Mazda North American Operations reserves the right to alter the specifications and contents of this bulletin without obligation or advance notice. All rights reserved. No part of this bulletin may be reproduced in any form or by any means, electronic or mechanical---including photocopying and recording and the use of any kind of information storage and retrieval system ---without permission in writing.

WARRANTY INFORMATION

NOTE: This repair is not covered under factory warranty as it is considered damage caused by the customer and not a defect. The repair can be goodwilled using Dealer Self Authorization (DSA) within term limits or contact Warranty for Preauthorization of the repair **for one time**.

Warranty Type	A
Symptom Code	99
Damage Code	99
Part Number Main Cause	KBB4-64-354
Quantity	1
Operation Number / Labor Hours:	YY841XRX / 0.5 Hrs

CONSUMER NOTICE: The information and instructions in this bulletin are intended for use by skilled technicians. Mazda technicians utilize the proper tools/ equipment and take training to correctly and safely maintain Mazda vehicles. These instructions should not be performed by "do-it-yourselfers." Customers should not assume this bulletin applies to their vehicle or that their vehicle will develop the described concern. To determine if the information applies, customers should contact their nearest authorized Mazda dealership. Mazda North American Operations reserves the right to alter the specifications and contents of this bulletin without obligation or advance notice. All rights reserved. No part of this bulletin may be reproduced in any form or by any means, electronic or mechanical---including photocopying and recording and the use of any kind of information storage and retrieval system ---without permission in writing.