

Uncontrolled Copy

ID # CBR-2299

Version 2

Title

Battery Electric Vehicle (BEV) - Vehicle Will Not "Start", Limited Speed, Instrument Cluster Showing Neutral After Gear Selected

Abstract

Certain BEV vehicles may present one or more of the symptoms below:

- Vehicle Turns On but won't start
- Vehicle will not go into any gear
- Cluster and Gear Selector display show neutral after a gear is selected, but the vehicle does select and move Forward/Reverse
- Truck is limited to first gear when Forward is selected
- Speed limited to ~25 MPH (~40 KPH)
- Low Power
- Truck will not charge

Valid for: Mack LR Electric, Volvo VNR Electric vehicles built for model year 2021 to current.

Content

Published 20 January 2025

Valid For

Mack LR Electric, Volvo VNR Electric vehicles built for model year 2021 to current.

Solution

Some BEV trucks may be subject to one or more of the symptoms:

- Vehicle Turns On but won't start
- Vehicle will not go into any gear
- Cluster and Gear Selector display show neutral after a gear is selected, but the vehicle does select and move Forward/Reverse
- Truck is limited to first gear when Forward is selected
- Speed limited to ~25 MPH (~40 KPH)
- Low Power
- Truck will not charge

 Live UI ble that the Selector Unit bushings and/or the Bores/Cylinders in the Compact Compound Bi-Directional Actuator are not adequately lubricated.

Materials Required:

- Super Lube 93003 O-ring Silicone Grease (pictured below)



Repair

► IMPORTANT ◀

The vehicle's compressed air system must be drained before proceeding with the procedure below.

A. Lubricate all of the components in the steps below using the above silicone grease and the linked document [here](#).

- 1. Ensure the vehicle's air system is drained completely**
- 2. Review the supplementary steps for the Extension Valve Unit in Part B below.** Photographs are needed in addition to procedures in the document.
- Lubricate all of the transmission components described in the document above.
 - Bushings and bores should be lubricated first.
 - O-rings and seals should then be lubricated and assembled.
 - All pistons should be lubricated last.

B. Lubricate the Electrical Valve Unit (EVU) assembly and related

Live UI **ients: Supplementary Instructions for use with document**

1. Remove the EVU.
2. Remove the Shift Detent.



3. Disassemble the Selector Unit. The Shift Rod and Fork should move back and forth about $\frac{3}{4}$ " (20mm).
 - The detent places a side load on the Shift Rod
4. Examine the Detent point and matching internal 1-N-2 geometry on the Shift Fork Yoke through the Detent access hole.

4.1. Photograph these components. Make the photos as clear and well-lit as possible. (Add light through the EVU sensor hole for photo if needed).

5. **Check:** Does the Detent Ball Bearing Roll?

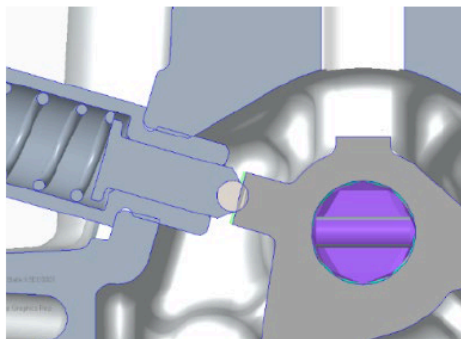
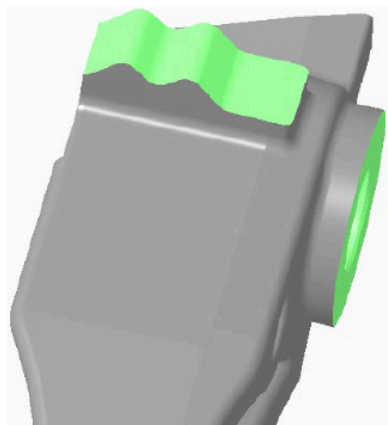

NOTE: The Detent Ball Bearing should not move or roll.

 Live UI

6. Lubricate the Selector Unit, especially the following Critical areas. If any parts show excessive wear, replace as needed.

- Front Bushing
 - Leave the Bushing in Main case.
 - Pull the Rod to the rear and lube bushing from the rear.
 - Push/pull the rod to work lube into front bushing.
- Rear Bushing in the Selector Unit Rear Cover: especially the selector rod machined notch to the bushing area.
 - **Photograph this component. Make the photos as clear and well-lit as possible.**
- Inner Cylinder Bore
- Outer Cylinder Bore
- All-O-rings and Seals

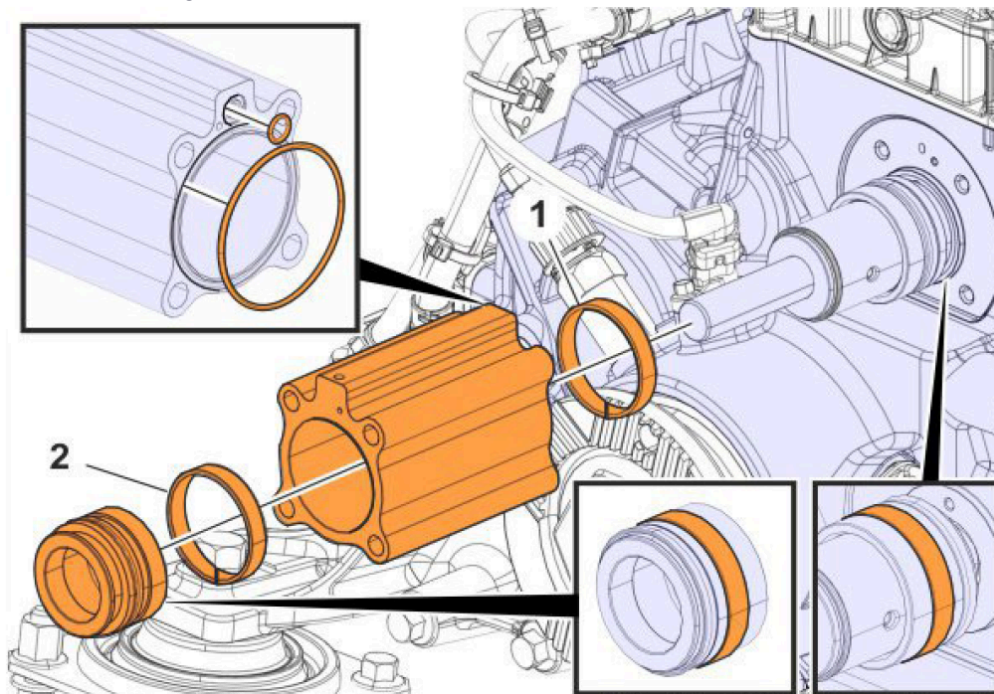

7. Lubricate the Detent and matching internal 1-N-2 geometry on the Shift Fork Yoke Detent Geometry, (through the Detent access hole).

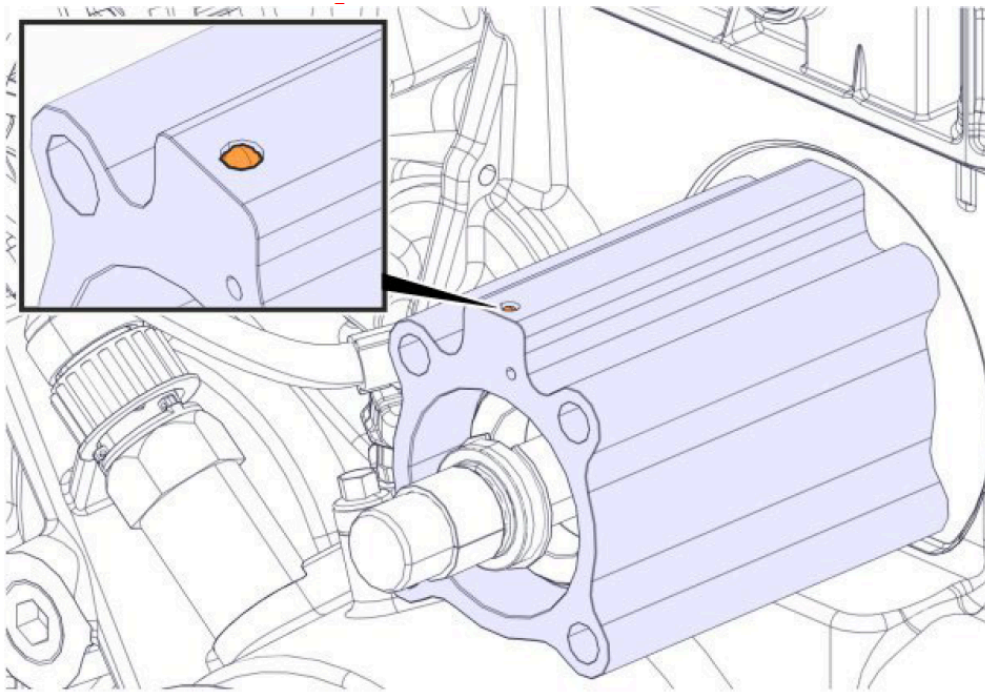

8. Apply House Air to the Air Port holes to cycle the Shifter Back and Forth once the Selector Unit is assembled.
9. With the Shift Fork in Forward position:
 - 9.1. Examine the EVU Plunger and matching internal geometry on the Shift Fork Yoke Bevel Geometry, (through the Plunger access hole).
 - 9.2. **Photograph these components. Make the photos as clear and well-lit as possible.**
 - 9.3. Lubricate the components.
 - 9.4. Reinstall the EVU.
10. Calibrate the Shift Forks **using the Resolver Function ONLY** (this is essential for engineering review).
11. Place the photos of the rebuild in an e-Service case and send the case to the eMobility Team.

Tags

bev mack volvo shut down wont start will not charge
will not start stuck in first gear 1st gear stuck in neutral

Categories *

Make and Model > Mack Americas > LR Electric

Make and Model > Volvo > VNR Electric

Vehicle System > Battery Electric Systems

Vehicle System > Transmission

Live UI