



TECHNICAL SERVICE BULLETIN

ISSUE DATE:	11/18/2021
SERVICE BULLETIN SUBJECT:	Access Doors Reinforcement Retrofit
VINs or MODELS AFFECTED:	Service Specified Buses
COMPLETE BY:	Next Service Opportunity
SERVICE BULLETIN #:	SC-21-166
LABOR OPERATION CODE:	FC48Z

NOTICE! It is expected that this process may require up to four hours per bus. Please schedule appropriately to minimize vehicle downtime.

ACCESS DOORS REINFORCEMENT RETROFIT

Description

The procedure describes the process of reinforcing the access door brackets.

Tools/Parts Required

Tools and Supplies Required:

- Ratchet
- Torx Socket Set
- Scissors
- Isopropyl Alcohol
- Shop Towels
- Calibrated Torque Wrench
- MA 530 Mixing Tips
- Paint Roller
- Latex Gloves
- Power Drill
- Metric Drill Bit Set
- 36-Grit Sanding Disks
- Cardboard
- Tongue Depressors
- Disposable Mixing/Scraping Tool
- Paint Mixing Sticks
- Standard and Metric Combination Wrench Sets
- Tape Measure
- Straight Edge
- Shop Towels

Kit Parts Required:

- 059807 Service Kit - Access Door Reinforcement (Consisting of)
 - 018575 LOCKNUT, HEX, M6-1.0, SST, DIN 6926-A2, NYLOCK 4 EA
 - 018082-007 SCREW, SOCKET BUTTON HEAD CAP, SS, M6-1.0X25 4 EA
 - 002139 RESIN, EPOXY, 4.35 GAL. JUG 1 EA
 - 050675 MEKP, COMPOSITE, BODY 1 EA
 - 018362 PLEXUS, MA-530 1 EA
 - 050674 VINYL ESTER PUTTY, COMPOSITE, BODY 1 EA
 - 018600-009 SCREW, PAN, PHIL, SS, M5-0.8X35X35 4 EA
 - 018574 LKNT, HEX FLANGE NYLON, SS, M5-0.8 4 EA
 - 042536 TOOL, SERVICE, MANUAL ADHESIVE GUN 1 EA

Additional Parts Required:

- 059807 FIBERGLASS CLOTH, COMPOSITE, BODY 10 FT

Trunk Body Ball Stud Brackets:

1. Perform the Proterra approved Lockout/Tagout procedure to make the bus safe for work.
2. Locate the two Ball Stud Brackets shown circled in red in the following illustration.



3. Determine if the Ball Stud Brackets have de-bonded from the body.
4. If the Ball Stud Brackets have not de-bonded, **proceed to step 15 in this section.**
5. Using a Heat Gun and Putty Knife, remove any excess Plexus from the Brackets and the Bus Body where the Brackets were mounted.
6. Using 36-Grit Sandpaper, scuff the Bus Body where the Ball Stud Brackets will be bonded.
7. Using a Power Drill with a 36-Grit Sanding Disk, scuff the bonding surface of each Ball Stud Bracket.
8. Using Isopropyl Alcohol and Shop Towels, clean the Ball Stud Brackets and the bonding areas on the bus.
9. Using a Plexus Gun with a clean tip, apply adhesive to the bonding surface of one of the Ball Stud Brackets.
10. Place the Ball Stud Bracket against the mounting surface of the bus.
11. Using a Tongue Depressor, remove any excess Plexus.
12. Secure the component for curing to the bus with Duct Tape.
13. Repeat the process to bond the other Ball Stud Bracket to the bus.
14. Allow the Plexus to cure for two hours before continuing the process.

15. Using the following illustration as a guide, mark the locations shown for drilling a hole through the Ball Stud Brackets and the Bus Body.

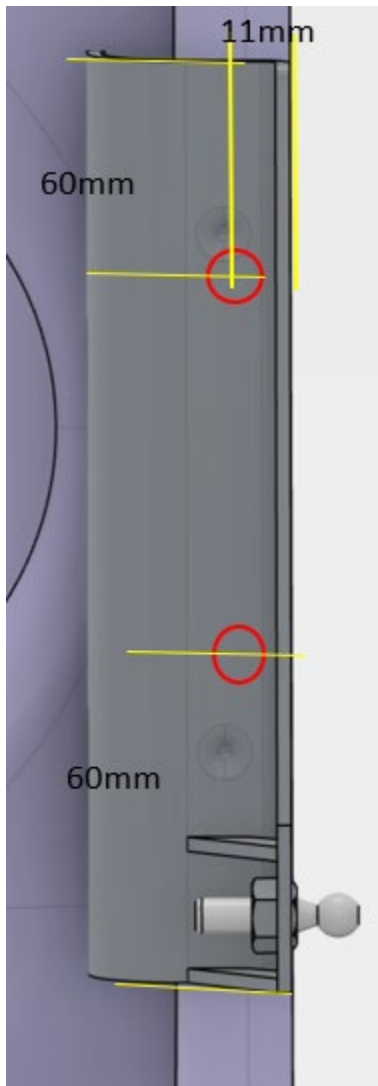

16. Using a Center Punch, dimple each marked location.
17. Using a Power Drill with a 1/8-Inch Drill Bit, drill a pilot hole in each location.
18. Using a Power Drill with a 1/4-Inch Drill Bit, enlarge each hole to its final size.
19. Repeat the process to drill two through holes on the other Ball Stud Bracket.
20. Using a 4mm Allen Driver and a 10mm Ratchet/Socket, secure the Ball Stud Brackets to the bus body using four M6 Bolts and four M6 Locknuts (018575).
21. Using a Calibrated Torque Wrench with a 10mm Socket and a 4mm Allen Driver, torque the fasteners to 60 inch pounds.
22. Using Orange Torque Stripe Paint, mark the properly torqued fasteners.

Trunk Door Ball Stud Brackets:

1. Locate the two Ball Stud Brackets on the Trunk Door as shown in the following illustration.

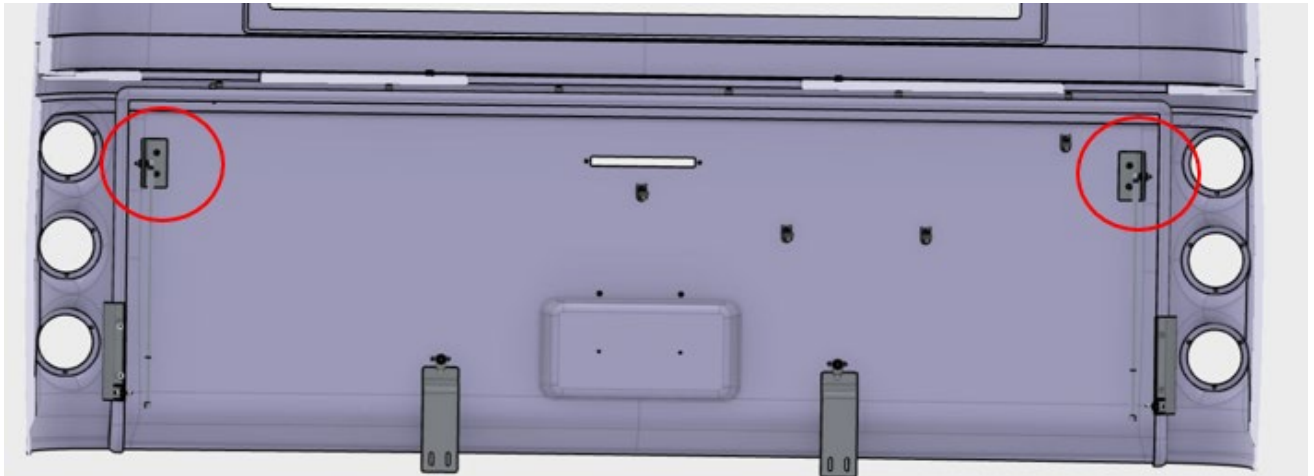

2. If the Ball Stud Brackets have not de-bonded, **proceed to step 13 in this section.**
3. Using a Heat Gun and Putty Knife, remove any excess Plexus from the Brackets and the Bus Body where the Brackets were mounted.
4. Using 36-Grit Sandpaper, scuff the Bus Body where the Ball Stud Brackets will be bonded.
5. Using a Power Drill with a 36-Grit Sanding Disk, scuff the bonding surface of each Ball Stud Bracket.
6. Using Isopropyl Alcohol and Shop Towels, clean the Ball Stud Brackets and the bonding areas on the bus.
7. Using a Plexus Gun with a clean tip, apply adhesive to the bonding surface of one of the Ball Stud Brackets.
8. Place the Ball Stud Bracket against the mounting surface of the bus.
9. Using a Tongue Depressor, remove any excess Plexus.
10. Secure the component for curing to the bus with Duct Tape.
11. Repeat the process to bond the other Ball Stud Bracket to the bus.
12. Allow the Plexus to cure for two hours before continuing the process.

13. Using a 13mm Combination Wrench, remove both Ball Studs from the Ball Stud Brackets.

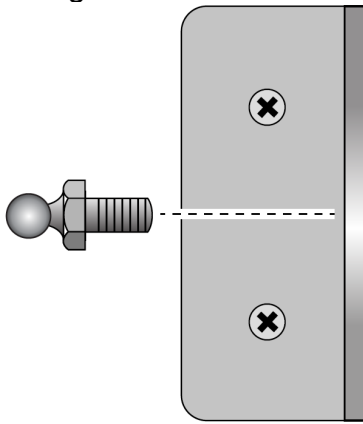

14. Using Scissors and a Tape Measure, cut two pieces of Biaxial Fiberglass Cloth (050677) to a size of 130mm by 65mm.

15. Using Scissors and a Tape Measure, cut two pieces of Biaxial Fiberglass Cloth (050677) to a size of 154mm by 77mm.

16. Set these aside for later use.

17. Using a flat piece of Cardboard as a mixing surface, mix a three inch diameter ball of VE Putty (050674) with ten cubic centimeters of MEKP (050675).

18. Using a Disposable Mixing Tool, mix the VE Putty (050674) and MEKP (050675) until the color is consistent.

19. Using Disposable Mixing Tool, apply the VE Putty (050674) around each Ball Stud Bracket (019082) as shown in the following illustration. Spread the VE Putty to create the smooth taper shown.

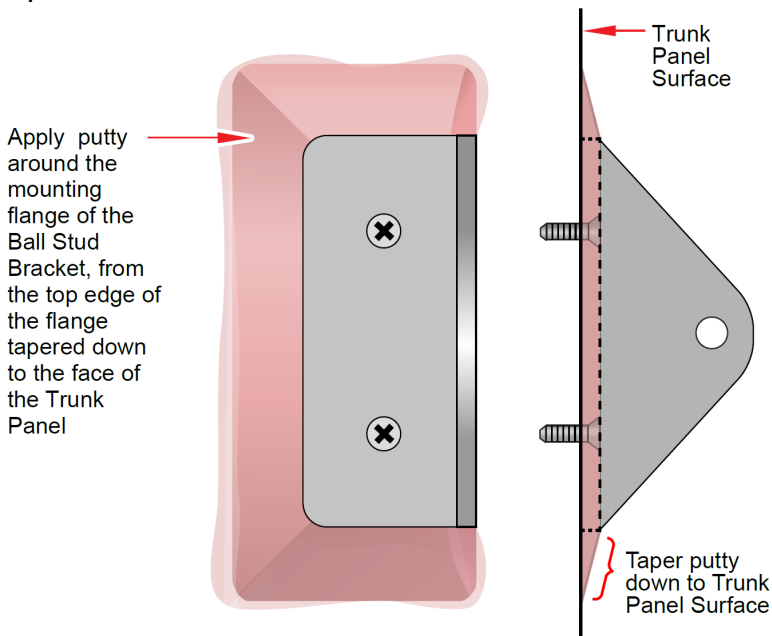

20. The Ball Stud Brackets (019082) should appear as shown in the following photograph after the VE Putty (050674) is properly applied.



21. Repeat the process to apply the VE Putty mixture to the other Ball Stud Bracket.
22. Using a Plastic Container and a Disposable Mixing Tool, combine 16 Fluid Ounces of Resin (002139) with 10 to 15 Cubic Centimeters of MEKP (050675).
23. Mix the combination thoroughly with a Disposable Mixing Tool.
24. Place the four cut sheets of Biaxial Fiberglass (050677) that were cut for the Ball Stud Brackets (019082) onto a flat sheet of Cardboard.
25. Using a Paint Brush, apply the mixture to one of the smaller cut sheets.
26. Using a Paint Brush, saturate the sheet.
27. When the sheet is saturated, flip it over and saturate the other side.
29. When both sides are saturated, place it over the Ball Stud Bracket as shown in the following illustration.

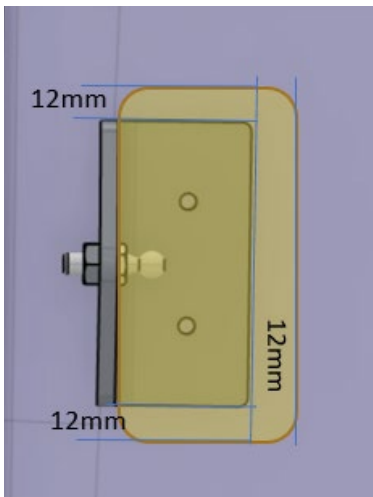

30. Repeat the process to fully saturate one of the larger sheets of Biaxial Fiberglass (050677).
31. When both sides are saturated, place it over the Ball Stud Bracket as shown in the following illustration.

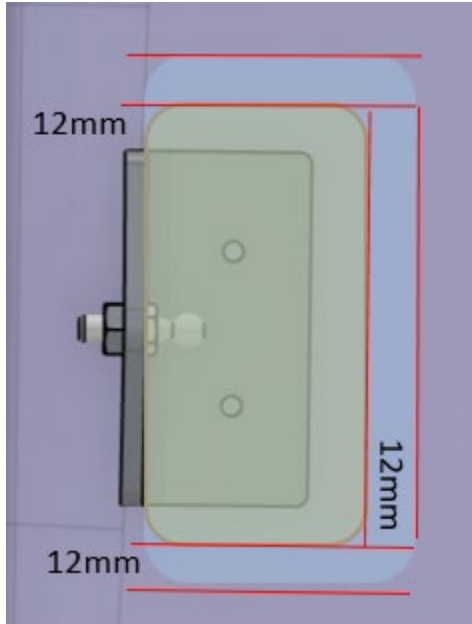

32. Repeat the process to apply the Biaxial Fiberglass (050677) to the other Ball Stud Bracket.

Lower Access Door Body Side Ball Stud Brackets:

1. Locate the two Ball Stud Brackets on the Streetside rear of the bus shown in the following illustration.

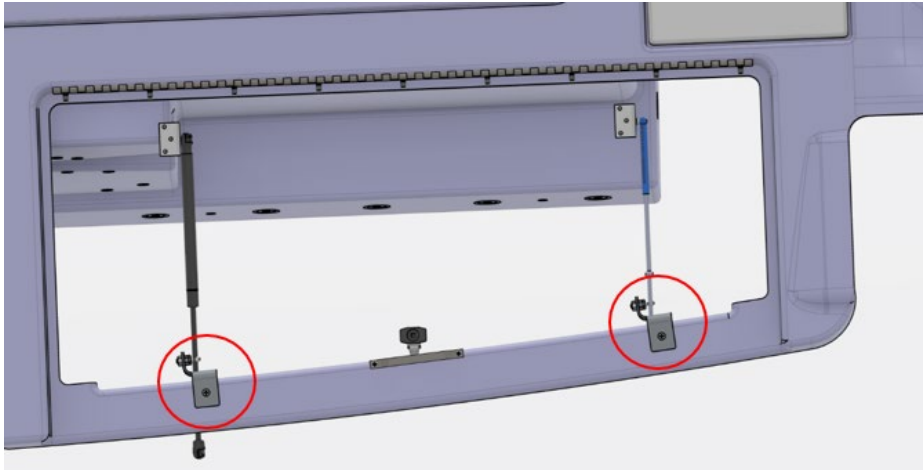

2. If the Ball Stud Brackets have not de-bonded, **proceed to step 13 in this section.**
3. Using a Heat Gun and Putty Knife, remove any excess Plexus from the Brackets and the Bus Body where the Brackets were mounted.
4. Using 36-Grit Sandpaper, scuff the Bus Body where the Ball Stud Brackets will be bonded.
5. Using a Power Drill with a 36-Grit Sanding Disk, scuff the bonding surface of each Ball Stud Bracket.
6. Using Isopropyl Alcohol and Shop Towels, clean the Ball Stud Brackets and the bonding areas on the bus.
7. Using a Plexus Gun with a clean tip, apply adhesive to the bonding surface of one of the Ball Stud Brackets.
8. Place the Ball Stud Bracket against the mounting surface of the bus.
9. Using a Tongue Depressor, remove any excess Plexus.
10. Secure the component for curing to the bus with Duct Tape.
11. Repeat the process to bond the other Ball Stud Bracket to the bus.
12. Allow the Plexus to cure for two hours before continuing the process.

13. Remove the Set Screws in the Ball Stud Brackets.
14. Using a Power Drill with 7/32-Inch Drill Bit or a 15/64-Inch Drill Bit, drill through each set screw hole and through the Aft Wrap.
15. Using a #2 Phillips Screwdriver and an 8mm Ratchet/Socket, secure the Ball Stud Brackets to the Aft Wrap using M5 Bolts (018600-009) and M5 Locknuts (018574).
16. Using a Calibrated Torque Wrench with an 8mm Socket and a #2 Phillips Screwdriver, **torque the fasteners to 35.4 inch pounds.**
17. Using Orange Torque Stripe Paint, mark the properly torqued fasteners.
18. Repeat the process to secure the Ball Stud Brackets on the Curbside of the bus.

Lower Access Door and Charge Door Body Side Ball Stud Brackets:

1. Locate the Ball Stud Brackets shown in the following illustration.

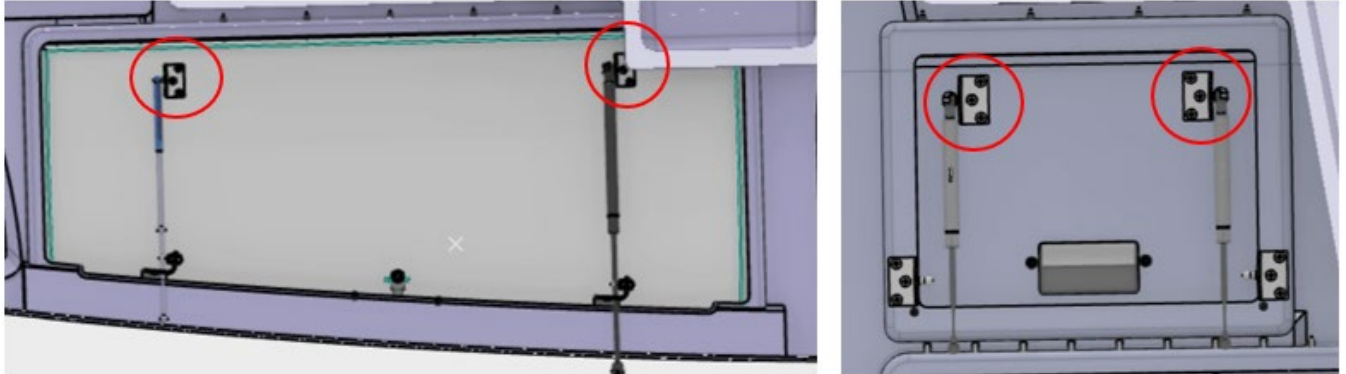

2. If the Ball Stud Brackets have not de-bonded, **proceed to step 13 in this section.**
3. Using a Heat Gun and Putty Knife, remove any excess Plexus from the Brackets and the Bus Body where the Brackets were mounted.
4. Using 36-Grit Sandpaper, scuff the Bus Body where the Ball Stud Brackets will be bonded.
5. Using a Power Drill with a 36-Grit Sanding Disk, scuff the bonding surface of each Ball Stud Bracket.
6. Using Isopropyl Alcohol and Shop Towels, clean the Ball Stud Brackets and the bonding areas on the bus.
7. Using a Plexus Gun with a clean tip, apply adhesive to the bonding surface of one of the Ball Stud Brackets.
8. Place the Ball Stud Bracket against the mounting surface of the bus.
9. Using a Tongue Depressor, remove any excess Plexus.
10. Secure the component for curing to the bus with Duct Tape.
11. Repeat the process to bond the other Ball Stud Bracket to the bus.
12. Allow the Plexus to cure for two hours before continuing the process.

13. Using Scissors and a Tape Measure, cut two pieces of Biaxial Fiberglass Cloth (050677) to a size of 130mm by 65mm.
14. Using Scissors and a Tape Measure, cut two pieces of Biaxial Fiberglass Cloth (050677) to a size of 154mm by 77mm.
15. Set these aside for later use.
16. Using a flat piece of Cardboard as a mixing surface, mix a three inch diameter ball of VE Putty (050674) with ten cubic centimeters of MEKP (050675).
17. Using a Disposable Mixing Tool, mix the VE Putty (050674) and MEKP (050675) until the color is consistent.
18. Using Disposable Mixing Tool, apply the VE Putty (050674) around each Ball Stud Bracket (019082) as shown in the following illustration. Spread the VE Putty to create the smooth taper shown.

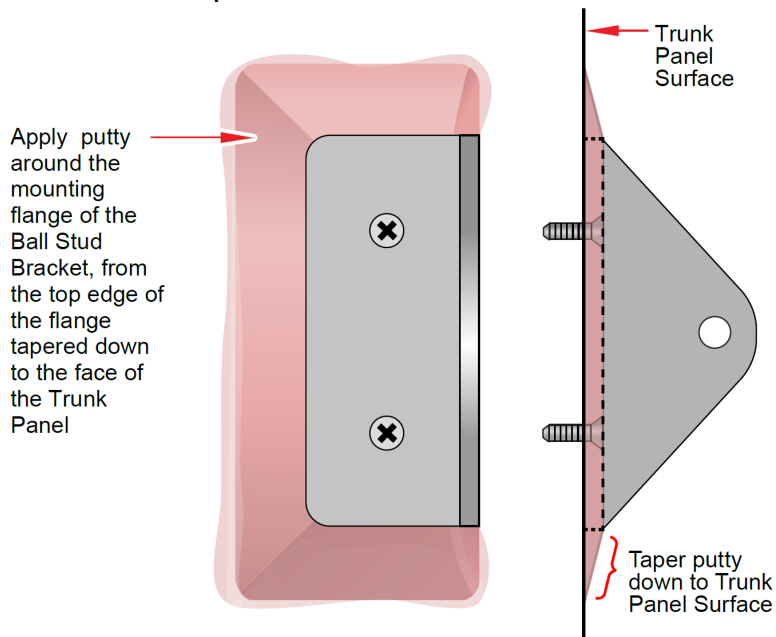

19. The Ball Stud Brackets (019082) should appear as shown in the following photograph after the VE Putty (050674) is properly applied.



20. Repeat the process to apply the VE Putty mixture to the other Ball Stud Bracket.
21. Using a Plastic Container and a Disposable Mixing Tool, combine 16 Fluid Ounces of Resin (002139) with 10 to 15 Cubic Centimeters of MEKP (050675).
22. Mix the combination thoroughly with a Disposable Mixing Tool.
23. Place the four cut sheets of Biaxial Fiberglass (050677) that were cut for the Ball Stud Brackets (019082) onto a flat sheet of Cardboard.
24. Using a Paint Brush, apply the mixture to one of the smaller cut sheets.
25. Using a Paint Brush, saturate the sheet.
26. When the sheet is saturated, flip it over and saturate the other side.
27. When both sides are saturated, place it over the Ball Stud Bracket as shown in the following illustration.

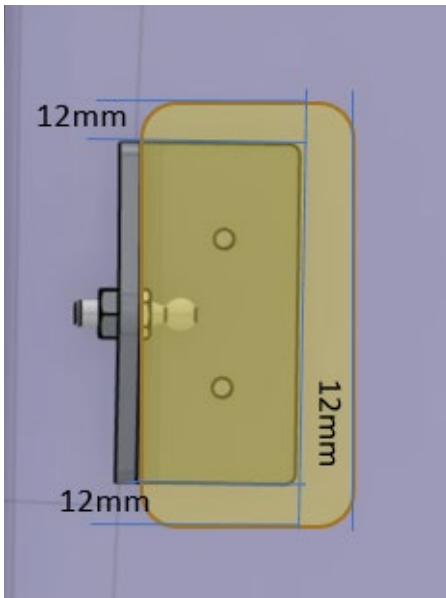

28. Repeat the process to fully saturate one of the larger sheets of Biaxial Fiberglass (050677).

29. When both sides are saturated, place it over the Ball Stud Bracket as shown in the following illustration.

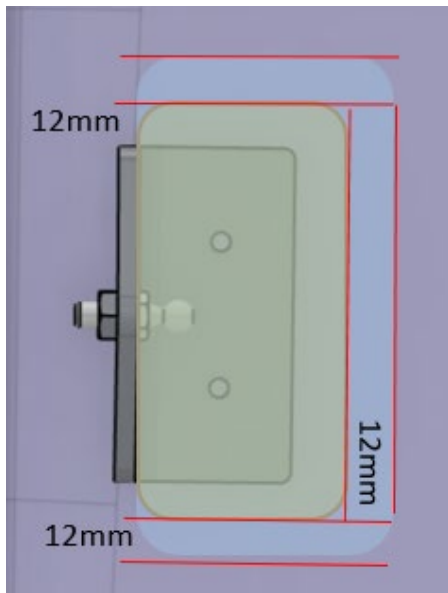

30. Repeat the process to apply the Biaxial Fiberglass (050677) to the other Ball Stud Bracket.
31. Remove the Lockout/Tagout devices and return the bus to service.