



## TECHNICAL SERVICE BULLETIN

<b>Subject</b>	ZX5.A01 BuSCoM 2.0 Software Release
<b>Issue Date</b>	5/8/2024
<b>Service Bulletin Number</b>	SC-24-013
<b>Models Affected</b>	Service Specified Vehicles
<b>Complete By</b>	Next Service Opportunity
<b>Labor Operation Code</b>	PP69Z
<b>Description</b>	Release to support bugs and enhancements for the ZX5.A01 fleet. The following ECUs will be updated throughout the procedure Dash (v5.3.0), Vehicle Controller (v3.13.08), Body Controller (v2.2.2), and Duo Power-

Labor Table				
	Operation	Technicians	Hours	Labor Time (T x H)
1	Steps 1-66	1	1.25	1.25 Hours
		<b>Total Labor Time:</b>		1.25 Hours

Contact the PhoenixEV Customer Service Team with any questions related to the following procedure.

**864-243-7572**

**[TransitWarranty@phoenixmotorcars.com](mailto:TransitWarranty@phoenixmotorcars.com)**



---

## **Overview:**

This document contains the necessary information and instructions to successfully program the vehicles ECUs for vehicle bugs and enhancements.

---

### **Added Features/Resolved Issues**

#### **BTMS System thermal efficiency and optimization**

- John Deere CalPro BTMS Efficiency changes to optimize battery performance across different operating temperatures

#### **Port B SW version Number on VCAN**

- Port B SW version will be available on VCAN to support PDT and Valence tools.

#### **Charge Controller CCID Communication for VIC and Port B**

- Restoring broadcast of CCID to re-enable remote tool monitoring functions.

#### **Metric Dash**

- Change to common units for all Metric customers based on field feedback.

#### **Vapor Door Switch Button Support**

- Software to support Vapor Doors with integrated ramp and ride height switch buttons

#### **Remington door obstruction response**

Change in the Remington door obstruction response to match the function in current Roadrunner fleet.

#### **VIC HVIL Faulted Shutdown improvement**

Increased VIC robustness to closing contactor under load condition on startup after faulted shutdown

#### **Compressor Diagnostic Robustness improvements**

SPN 1351 FMI 7 false failure fix

#### **Power steering Diagnostic Robustness improvements**

- SPN 520855 FMI 7 Power steering compressor RPM target and diagnostic maturity time change to prevent false failure during normal operation

---

## **HV Diagnostic Robustness improvements**

- BMS waking cyclically under corner case Port B charging scenario fix, shunt voltage diagnostic fixes

## **Vapor Door Sensitive Edge Improvements**

- Fixes bug preventing correct operation of drag detection and sensitive edge.

## **Rooftop Pack flow improvement**

- For buses equipped with Valeo HVAC increased flow through rooftop packs
- Requires hardware update on Valeo buses before implementation
- No changes for non-Valeo

## **Interlock Fault Robustness Improvements**

- Changes to prevent false failure of interlock diagnostics causing red fault lamp
- SPN 520821 FMI 1
- SPN 520822 FMI 1

## **Critical Battery Fault Improvements**

- ESM monitors moisture and isolation signals from BMS to detect critical battery faults.

---

## Prerequisites:

The vehicle must have the previous software campaign complete SC-23-052, specifically the LVD contactor must set to its new parameters and shutdown override switch to be a momentary switch. If the vehicle does not have a WO signed off please verify the shutdown override switch is momentary before proceeding.

For best results during this flashing procedure, have the LV batteries fully charged, if the batteries cannot sustain the bus to be in low voltage for 30 minutes at a time it is required to have an external battery bank to support the bus during the flashing procedure.

The same applies to your laptop, must be fully charged and able to hold power continuously through the flashing procedure.

Have all software files stored on the local harddrive of the laptop. Using a file that is located on the cloud can cause undesirables results.

If all these conditions are not met for this procedure you run the risk of bricking a controller resulting in unexpected downtime.

If vehicle powertrain is not **equal to or greater than 4.0.0** on the PCM this campaign must be put on hold due to Phoenix Diagnostic tool issues. The PCM will not be configurable on the PDT and 4.0.0 released new EEPROMs

Following the link below please have the Manufacturing Diag Tool installed on your laptop to update a VIC EEPROM.

<https://diag.phoenixmotorcars.com/mdt/>

---

Software Link:

[https://business-site-7460.my.salesforce.com/sfc/p/Ho000002fy70/a/Ho000000Btcx/76vMbcaBsHPmrOVzS9P\\_ujicB8gX\\_AjM2mVwA65Om9Y](https://business-site-7460.my.salesforce.com/sfc/p/Ho000002fy70/a/Ho000000Btcx/76vMbcaBsHPmrOVzS9P_ujicB8gX_AjM2mVwA65Om9Y)

Password: Hck3FjyD

---

## VEHICLE SOFTWARE UPDATE PROCEDURE

### Step 1:

Turn ON the 12/24V rear Vehicle Master Disconnect located at the curbside rear charge port access panel and the LV Battery Saver Switch near the LV batteries.



---

### Step 2:

Connect the Nexiq USB Link2 device to the laptop and to the OBDII Diagnostic Port located in the rear deck above the rear window.

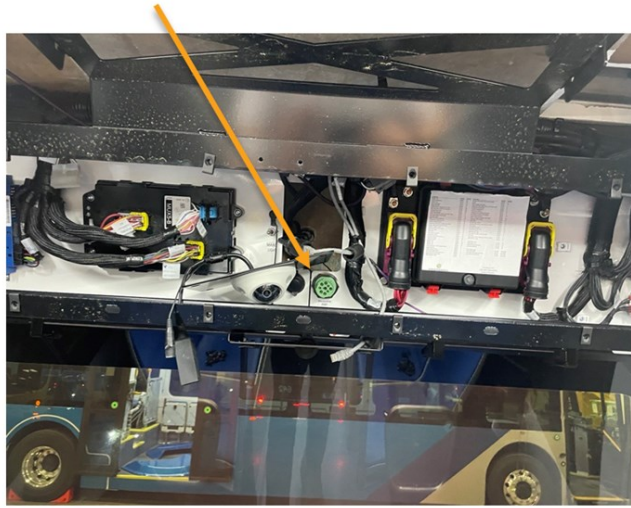

---

### Step 3:

Make sure the Master Switch is in the “OFF” position and the Hazard Switch is “ON”.

**Note**– Other Systems may cause the hazard lights to be on. Ensure the hazard switch is on for flashing purposes.



---

### Step 4:

On the laptop, double-click on the Phoenix Diagnostics Tool software icon to start the software.

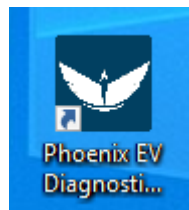

---

### Step 5:

When the program opens, read and click “OK” for the high-voltage safety prompt

---

### Step 6:

On the Home tab, select the appropriate device from the drop down and click “Connect”



---

### Step 7:

Once the diagnostic tool has connected to the vehicle, a VIN number and connection status will be displayed on the Home screen, and tabs available to navigate. If you do not see the Home Screen, check that the low-voltage batteries are connected and that the Nexiq tool is plugged in. If there are still errors, try restarting the Phoenix Diagnostic Tool application.

**NOTE:** 800V Protterra vehicles are equipped with an automatic battery disconnect that will protect the low-voltage batteries from a deep discharge.

---

### Step 8:

Before beginning the programming process, check the bus for existing faults by clicking on the “Diagnostics” button below and make a note of any found.

---

### Step 9:

Click on the “Overhead Charging” button on the left side of the screen.

**NOTE:** If the bus that you are working on is not capable of overhead charging, skip the next step.

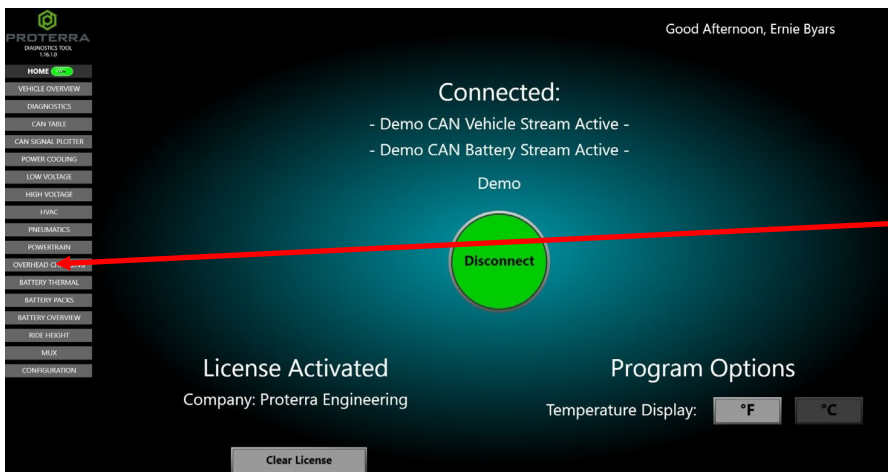

Click “Overhead Charging”

### Step 10:

Record the value displayed in the “Vehicle Tag” data field. This will be re-entered into the controller after the software update.

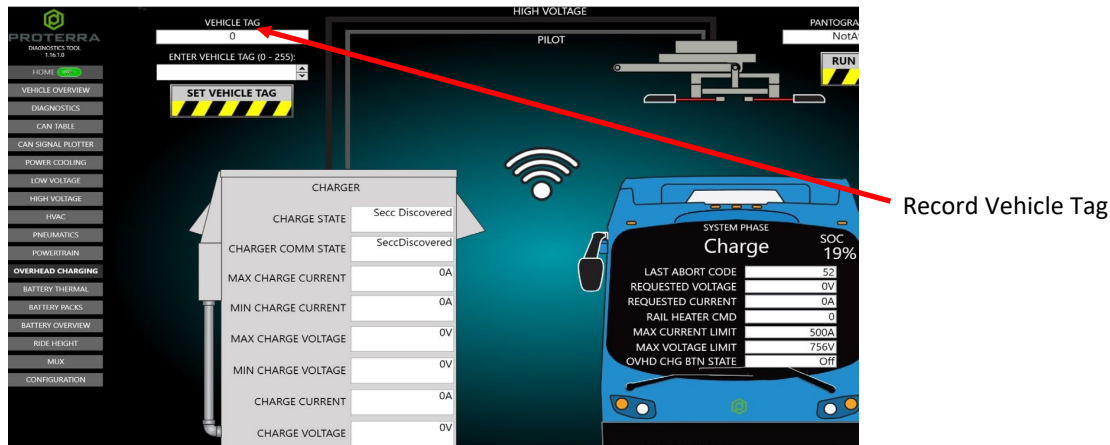

### Step 11:

Navigate to the “VIC CONFIG” tab in the left menu.

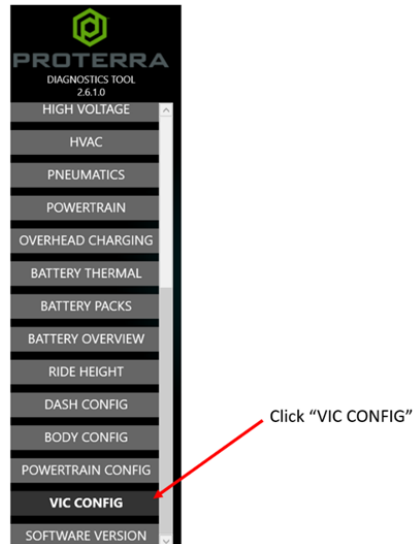

### Step 12:

Select the option for Vehicle Controller “START FLASH”. There will be a status pop-up to confirm that the Master Switch is OFF, and the Hazard Switch is ON.

NOTICE: The “INITIAL FLASH” button is only for offline programming of the Vehicle Controller with an Offline Programming Kit.

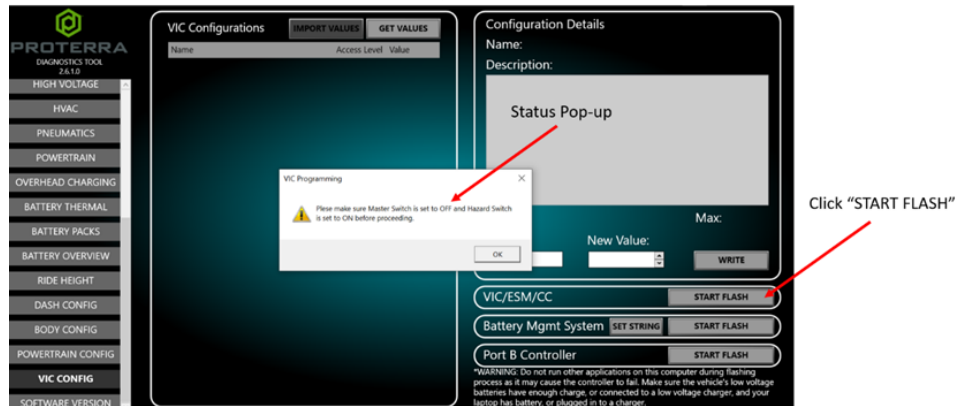

### Step 13:

After pressing OK, it will prompt you to press the “START FLASH” button again. BEFORE YOU DO THAT, press the “GET VALUES” button to get the current controller configuration values. Save these values in case the automatic restore does not work.

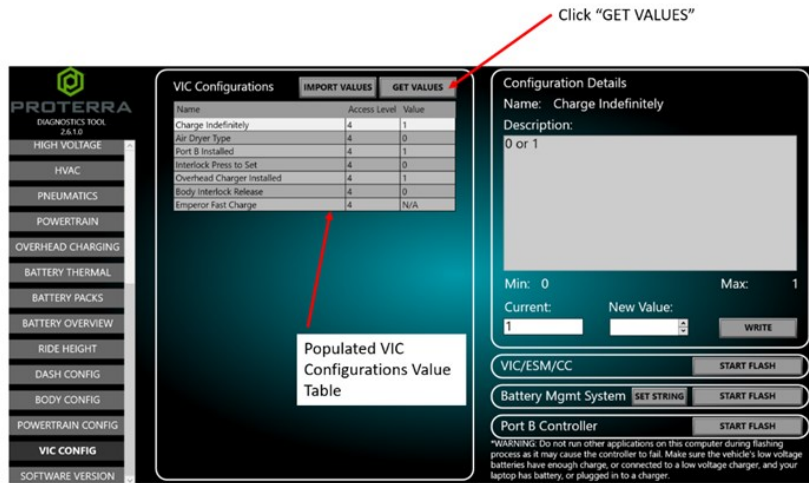

### Step 14:

Now, press the “START FLASH” button once more and a pop-up window should appear. In the pop-up window, select the software flash file to load the controller. The correct file is named “VIC\_Remington\_v3\_13\_08.hex”.

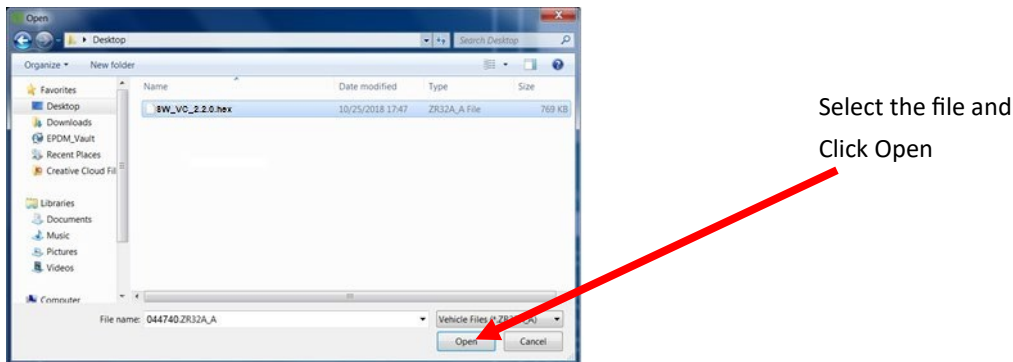

### Step 15:

The Programming window will come up and will take a few minutes to complete.

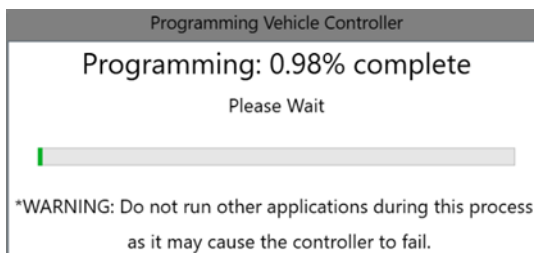

---

**Step 16:**

Click on the “Overhead Charging” button on the left side of the screen.

**NOTE:** If the bus that you are working on is not capable of overhead charging, skip the next step.

---

**Step 17:**

The following screen will appear. Enter the “Vehicle Tag” that you recorded previously into the field circled in red below. Click the button under the field. This will populate the “Vehicle Tag” into the field above and into the controller.

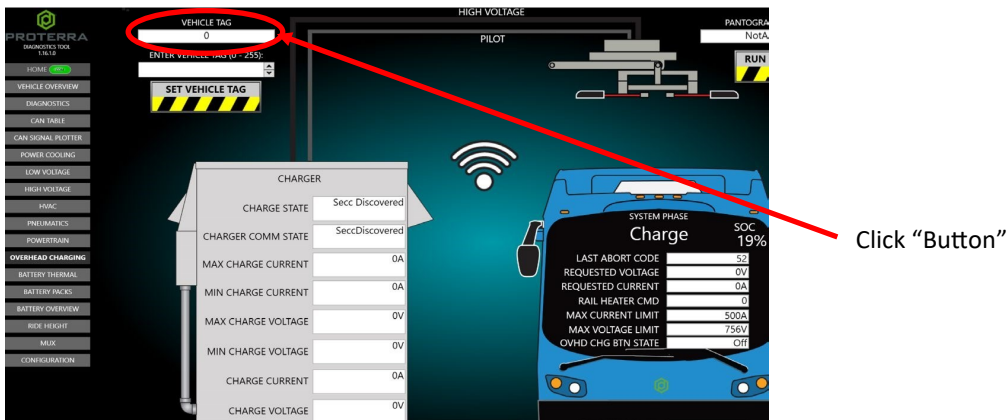

---

**Step 18:**

Set EEPROM “Emperor Fast Charge” to 0. If you cannot see the EEPROM on the PDT, use the MDT tool. Link provided above.

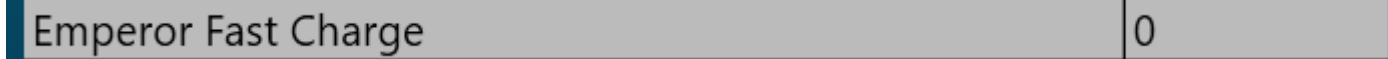

---

**Step 19:**

Turn the Hazard Switch OFF, Turn OFF the Master Switch. Turn off the Master Disconnect and battery saver switch.

Close the PDT.

---

## DUOPOWER POWERTRAIN SOFTWARE UPDATE PROCEDURE

**Step 20:**

Turn ON the 12/24V rear Vehicle Master Disconnect located at the curbside rear charge port access panel and the LV Battery Saver Switch near the LV batteries.

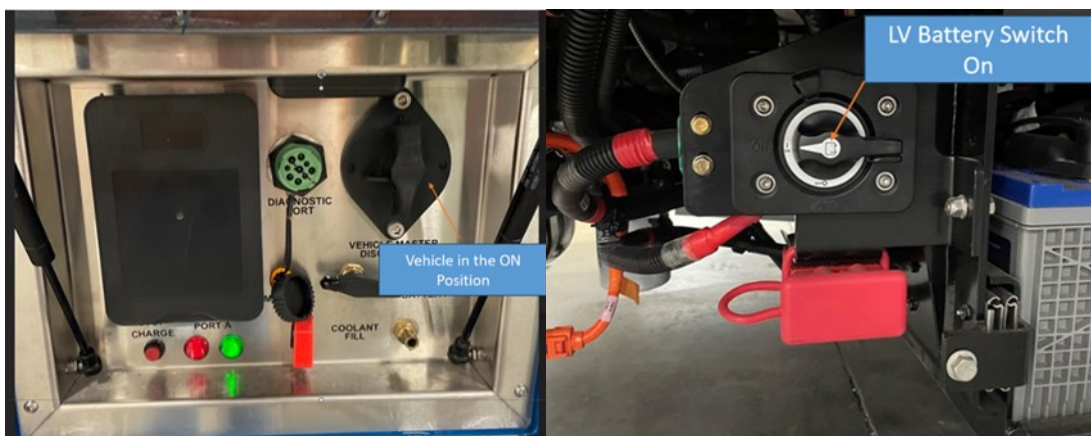

---

**Step 21:**

Turn the Master Switch to the “DAY RUN” position and turn the Hazard Switch ON and record the Odometer Value.

**NOTE** – DO NOT PRESS THE START PB. THIS WILL ENGAGE HV.

**NOTE** – Other systems may cause the hazard lights to be on. Ensure the Hazard Switch is on for flashing purposes



---

**Step 22:**

Access the Rear Deck above the rear window and remove the protective cap.

---

**Step 23:**

Connect to the vehicle using the Nexiq USB Link2 and PDT similarly to the steps above in the Vehicle controller flashing procedure.

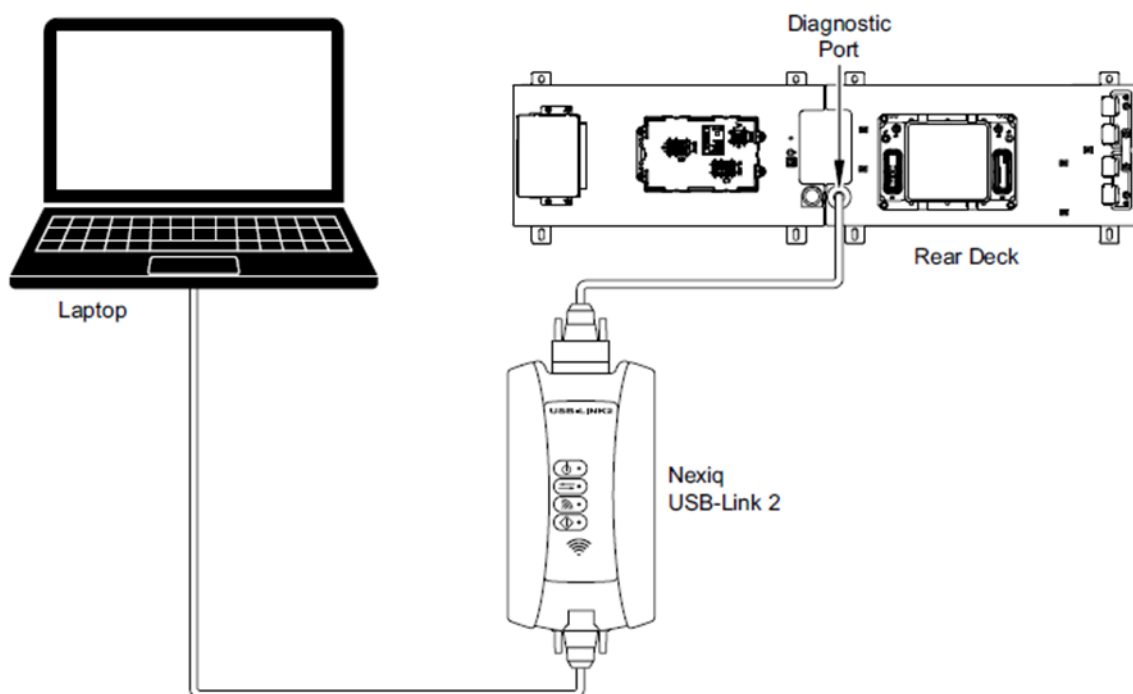

---

**Step 24:**

On the laptop, double-click on the Phoenix Diagnostics Tool software icon to start the software.

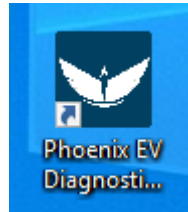

---

**Step 25:**

When the program opens, read and click "OK" for the prompt

---

**Step 26:**

On the Home tab, select the appropriate device from the drop down and click "Connect".

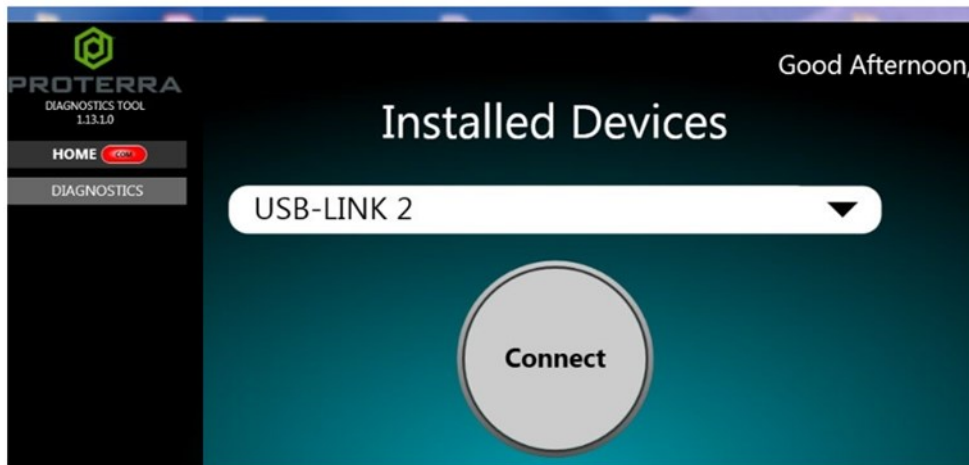

---

**Step 27:**

Once the diagnostic tool has connected to the vehicle, a VIN number and connection status will appear on the Home screen, along with selectable tabs to navigate

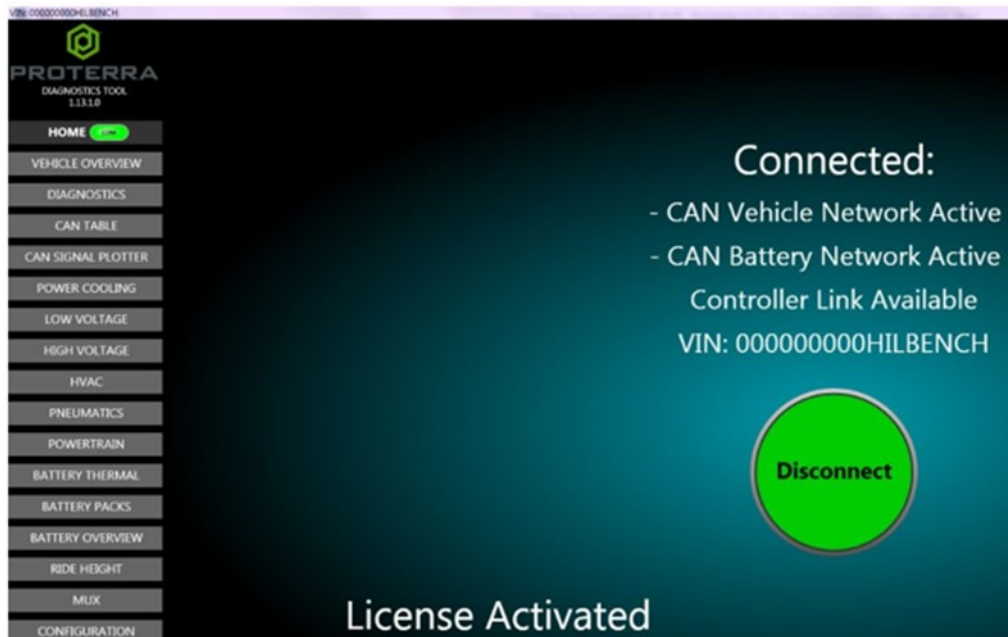

---

**Step 28:**

Ensure you have the latest software file “066116.hex“ on the computer's hard drive.

---

**Step 29:**

Click on the “Powertrain Config” tab on the left-hand side of the screen.

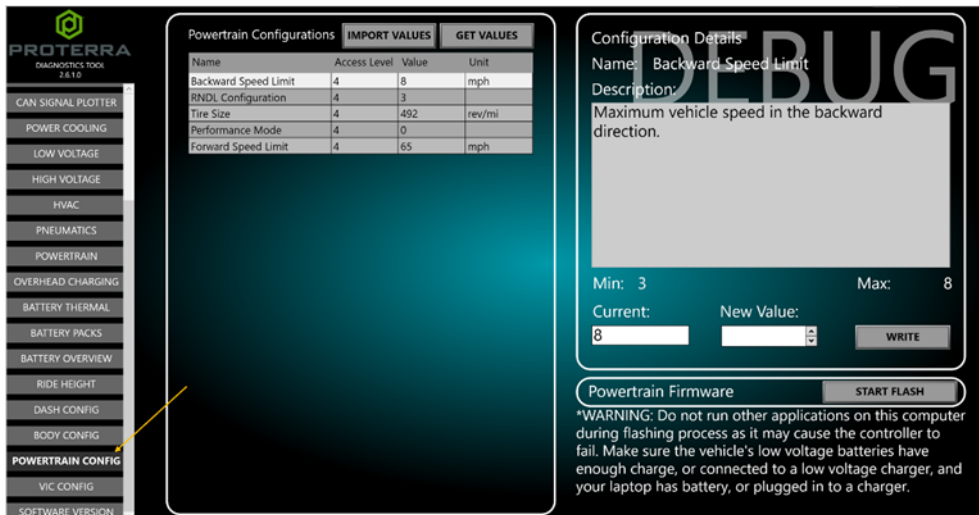

---

**Step 30:**

On the Powertrain Configurations tab, Click on “Get Values”.

---

**Step 31:**

After clicking on Get Values, note down the values set for Forward Speed limit, Backward Speed Limit, Tire Size, Performance Mode, RNDL Configuration, Yard Speed Limit, and Odometer for future reference.

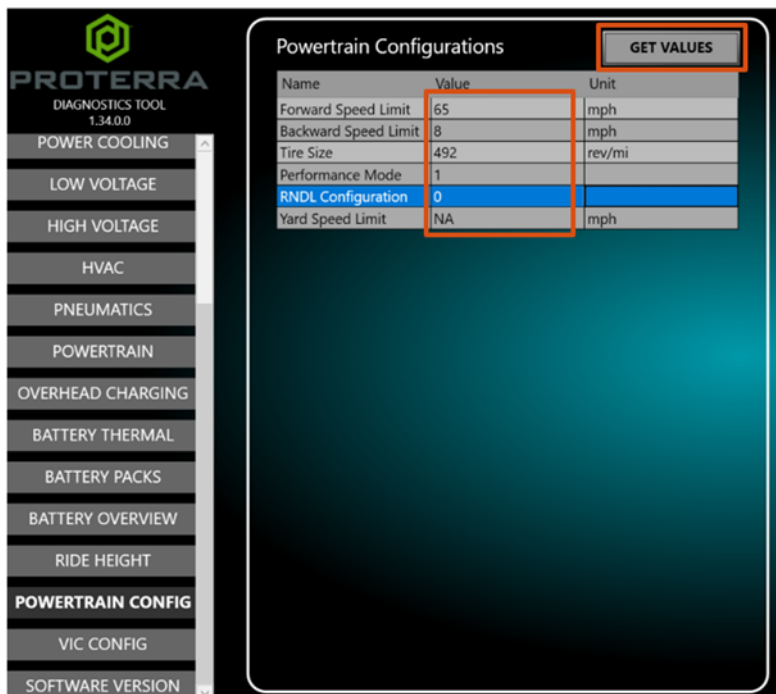

### Step 32:

Click the Powertrain Firmware “Start Flash” button.

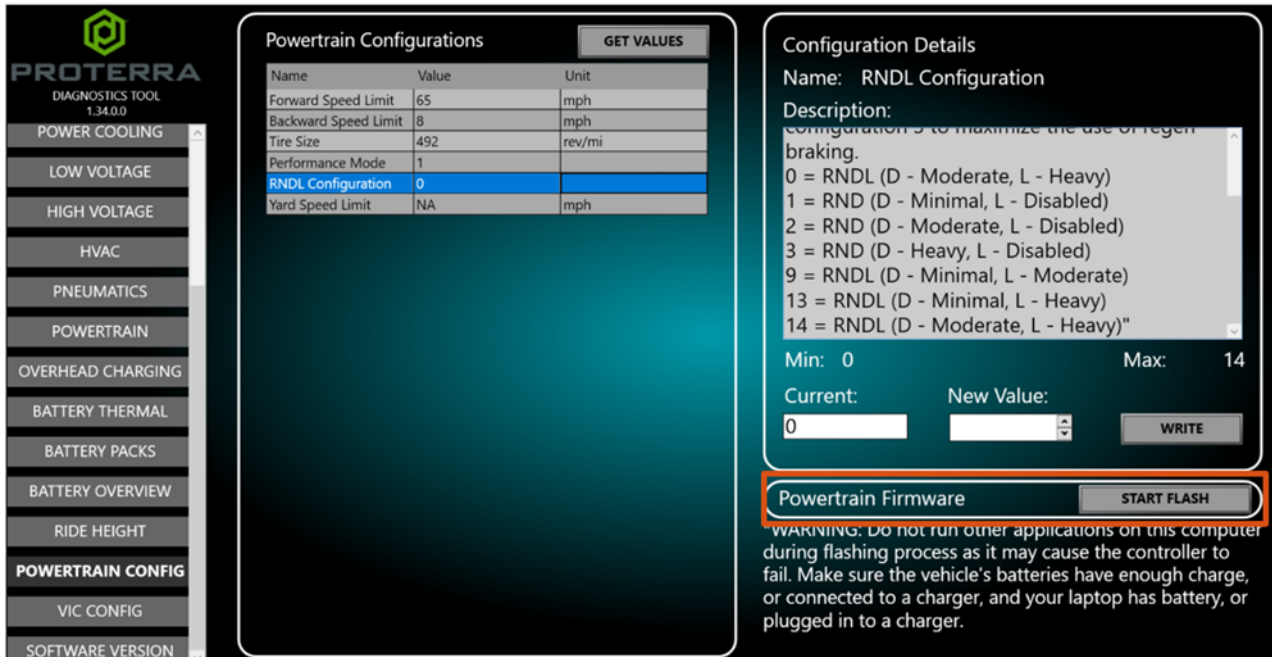

### Step 33:

The following screen will be displayed. Navigate to the location where you stored the configuration file earlier. Select the software file downloaded previously and click “Open” to load the “066116.hex” file.

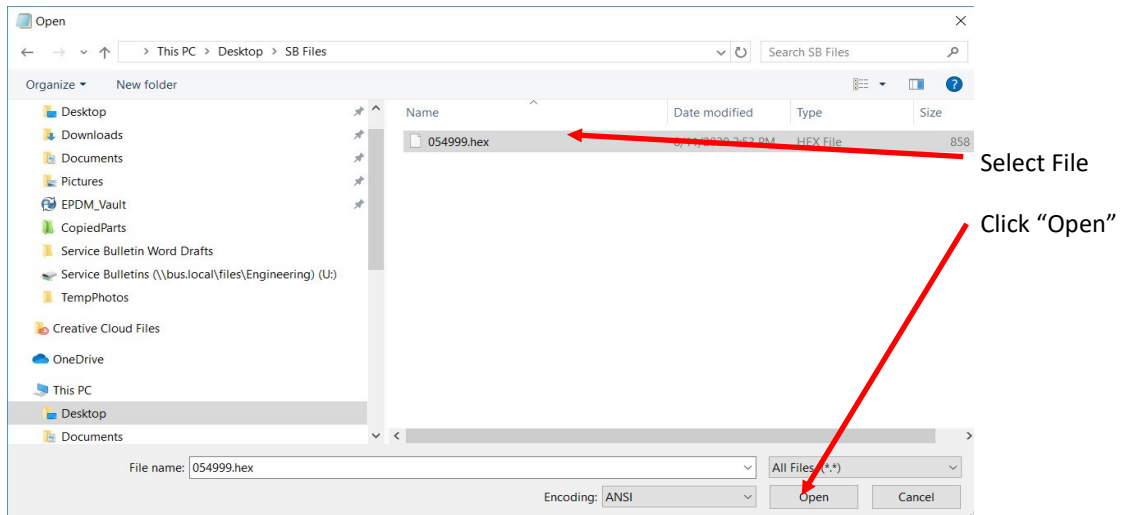

### Step 34:

The Phoenix Diagnostic Tool will attempt to connect to the device.

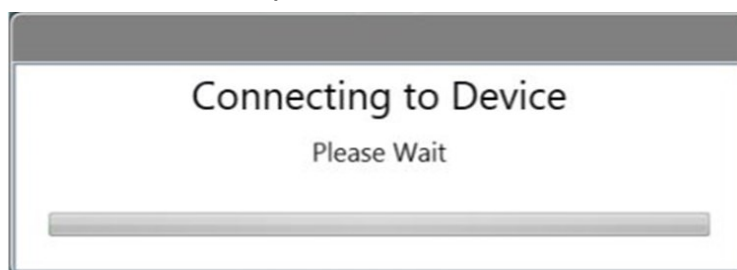

---

**Step 35:**

When the software update begins, the following screens will be displayed.

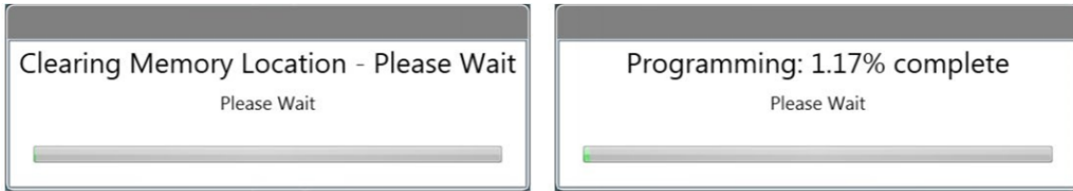

---

**Step 36:**

The software update may take several minutes to complete. When the update is complete the following will be displayed. Click the “OK” button to complete the update process.

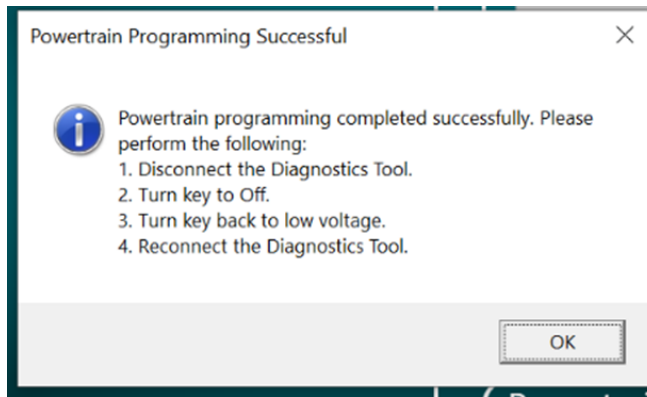

---

**Step 37:**

Disconnect the diagnostic tool and turn the Master Switch to **OFF**, the Hazard Switch **OFF**, and then turn the Master Switch back to DAY RUN and the Hazard Switch back **ON**.

---

**Step 38:**

Reconnect the Phoenix Diagnostic Tool.

---

**Step 39:**

Check the odometer value displayed on the dash, if it doesn't match the recorded value, then pro-

---

**Step 40:**

Navigate to the Powertrain tab and type the recorded odometer value in the Odometer value field, then click “Set odometer value.”

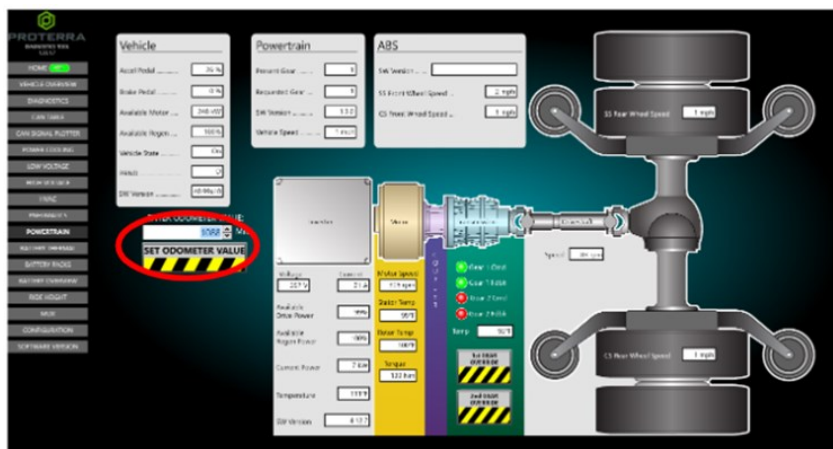

---

**Step 41:**

The Phoenix Diagnostic Tool will display the following when the odometer update process completes successfully. If the Proterra Diagnostic Tool displays Failed or Timeout please check for active faults on the Diagnostics tab.

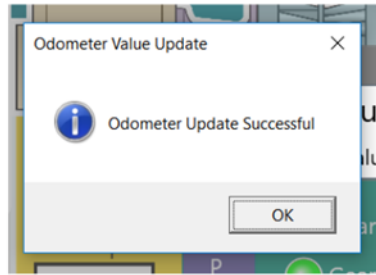

---

**Step 42:**

Verify that the odometer value displayed on the dash matches the recorded odometer value. Note that it's okay if the new odometer value differs by up to 1 mile. The odometer update process is now complete.

---

**Step 43:**

Navigate to the "Powertrain Config" tab and click on "Get Values".

---

**Step 44:**

Verify all the configurations are same as noted previously.

---

**Step 45:**

If the configurations are same, then the programming process is complete, else go to the next step.

---

**Step 46:**

Reset the configurations by selecting each configuration parameter individually.

---

**Step 47:**

Enter the value noted in steps above, in the "New Value" box and click on the "WRITE" button for each parameter.

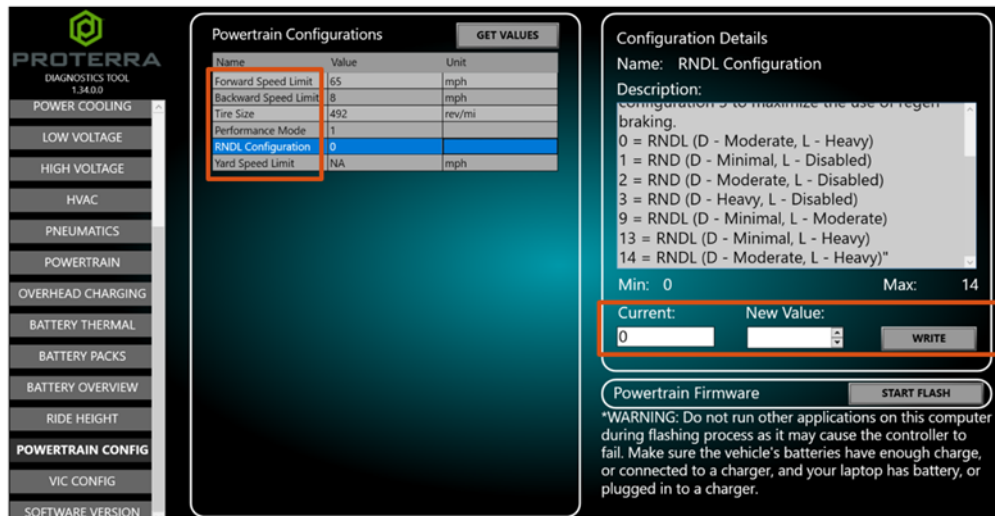

---

**Step 47:**

Close PDT.

---

## **BODY CONTROLLER SOFTWARE UPDATE PROCEDURE**

### **Step 48:**

Turn on the 12/24V rear Vehicle Master Disconnect located behind the vehicle curbside rear charge port access panel.

---

### **Step 49:**

Make sure the Master Switch is OFF and the Hazard Switch is ON.



---

### **Step 50:**

Access the Rear Deck above the rear window and remove the protective cap.

---

### **Step 51:**

Connect to the vehicle using the Nexiq USB Link2 and PDT .

---

### **Step 52:**

On the laptop, double-click on the Phoenix Diagnostics Tool software icon to start the software.

---

### **Step 53:**

When the program opens, read and click “OK” for the prompt.

---

### **Step 54:**

On the Home tab, select the appropriate device from the drop down and click “Connect”.

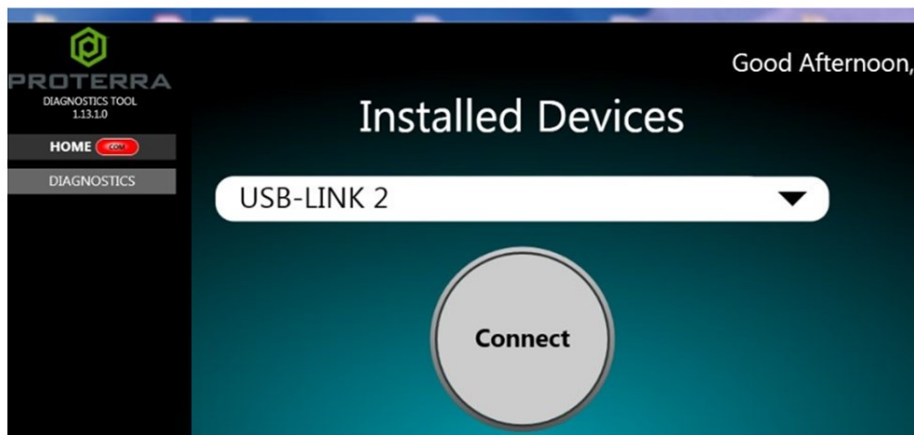

### Step 55:

Ensure you have the latest software file “Body\_2\_2\_2\_pn066281.mhx” on the computer’s hard drive.

### Step 56:

After connecting to the vehicle using the Phoenix Diagnostic tool at the Diagnostic Port, navigate to the “Body Config” tab

The screenshot shows the Phoenix Diagnostic tool interface. On the left is a navigation menu with 'BODY CONFIG' highlighted. The main area is split into two panels. The left panel, titled 'Body Parameters', contains a table with columns 'Name', 'Access Level', and 'Value'. The right panel, titled 'Parameter Details', shows details for 'NVP\_CORE\_DaytimeRunning', including a description 'Daytime Running Lights', a 'WRITE' button, and a 'Body Firmware' section with 'SET VIN' and 'START FLASH' buttons. A large 'DEBUG' watermark is overlaid on the right panel.

Name	Access Level	Value
NVP_DOOR_EntranceTimeLimit	4	30
NVP_EXLI_BrakeLightsDuringRegen	4	1
NVP_HVAC_HeatIsoMonitor	4	0
NVP_HVAC_HeatCycleWithCharger	4	0
NVP_DWC_SeatBeltSensor	4	0
NVP_OPTN_BrakeWearLimit_pct	4	10
NVP_CORE_LVIdleTimeLimit_min	4	30
NVP_CORE_HVIdleTimeLimit_min	4	30
NVP_CORE_RearRunHVTimeLimit_min	4	0
NVP_INLK_AntiTheftSecurity_xx	1	0
NVP_INTLI_CleanTime	4	15
NVP_INLK_AntiTheftCANTimeout_min	1	0
NVP_OPTN_TPMSInstalled	4	0
NVP_DOOR_DoorType	4	0
NVP_DOOR_CSFStandStillRRRCrossing	1	0
NVP_INLK_ITSAutoNeutral	1	0
NVP_EXLI_HazardsWhenDoorsOpen	1	0
NVP_DWC_DriverInSeatSensor	4	0
NVP_DWC_FansOffWhenFDoorOpen	1	0
Cornering Lights options	1	0
seconds to leave ADA underseat lights on	1	0
NVP_INTLI_WorkTime	4	30
LVD Time Delay EEPROM	1	5
NVP_EXLI_RampLights	4	2
NVP_EXLI_RHSCLights	4	2
NVP_EBUZ_RampAudible	4	1

### Step 57:

Select “Get Values”. To store a back up copy of the EEPROMs.

### Step 58:

Select start Flash on the “Body Config” Tab.

The screenshot shows the Phoenix Diagnostic tool interface. On the left is a navigation menu with 'BODY CONFIG' highlighted. The main area is split into two panels. The left panel, titled 'Body Parameters', contains a table with columns 'Name', 'Access Level', and 'Value'. The right panel, titled 'Parameter Details', shows details for 'NVP\_CORE\_DaytimeRunning', including a description 'Daytime Running Lights', a 'WRITE' button, and a 'Body Firmware' section with 'SET VIN' and 'START FLASH' buttons. A large 'DEBUG' watermark is overlaid on the right panel.

Name	Access Level	Value
NVP_CORE_DaytimeRunning	4	1
NVP_INTLI_CSFWalkwayLights	4	3
NVP_EBUZ_AlertDuringKneel	4	1
NVP_EBUZ_AudibleTurnSignal	4	0
NVP_HVAC_FixedCabinSetpoint	4	20
NVP_HVAC_AuxHeaterInstalled	4	0
NVP_HVAC_MinOnlyDieselTime_min	4	60
NVP_HVAC_MinOnlyElectricTime_min	4	10
NVP_HVAC_NoAuxWithCharger	4	0
NVP_HVAC_MaxAuxHeatMainTemp	4	10
NVP_INLK_InterlockOverrideAlarm	4	1
NVP_DOOR_CSFDoorInterlockSetting	4	0
NVP_INTLI_CSRWalkwayLights	4	3
NVP_DOOR_CSRDoorInterlockSetting	4	1
NVP_RHSC_InterlockDuringKneel	4	1
NVP_INLK_SeparateINLKOverrides	4	0
NVP_DOOR_CSFStandStillSpeed_mph	4	3
NVP_DOOR_CSFStandStillOverride	1	0
NVP_RHSC_DrivingHeightEnabled	4	1
NVP_RHSC_ParkBrakeForKneel	4	0
NVP_RHSC_KneelSetting	4	2
NVP_RHSC_FDoorOpenReqForKneel	4	0
NVP_RHSC_DisableAutoAdjustDoors	4	0
NVP_INTLI_SSFWalkwayLights	4	3
NVP_RHSC_DoorsClosedForKneel	4	0
NVP_RAMP_ParkBrakeForRamp	4	0
NVP_RAMP_KneelMainRampDeploy	4	1

## Step 59:

Select the Body SW “Body\_2\_2\_2\_pn066281.mhx”. The extension type must be .MHX file.

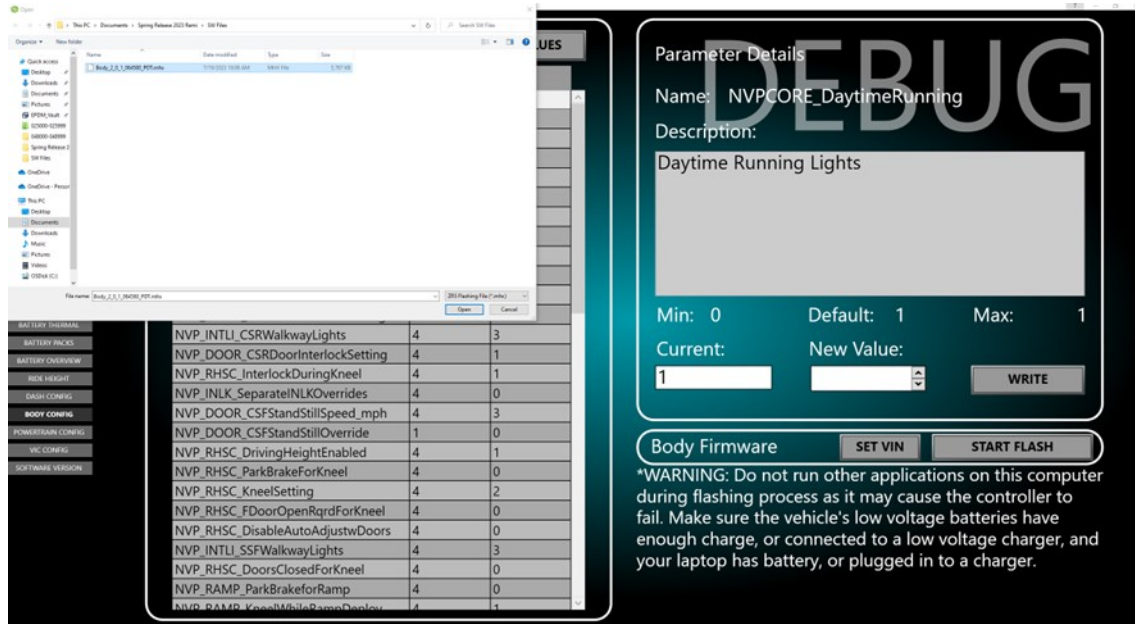

## Step 60:

Once the SW is flashed the following screen will pop up. Select “Ok”. Then close the PDT and remove connection to the bus.

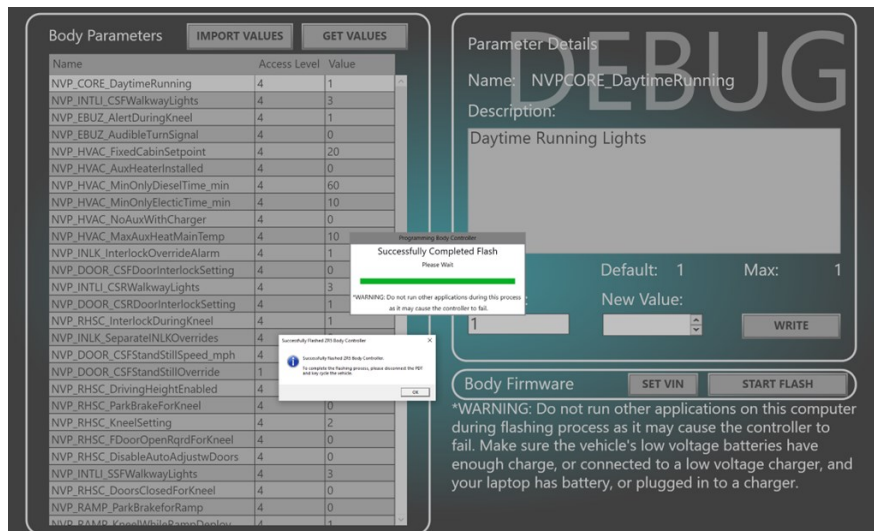

## Step 61:

Power down the bus at the Curbside Rear, turn both the Vehicle Master Disconnect and LV Battery Switch to OFF.

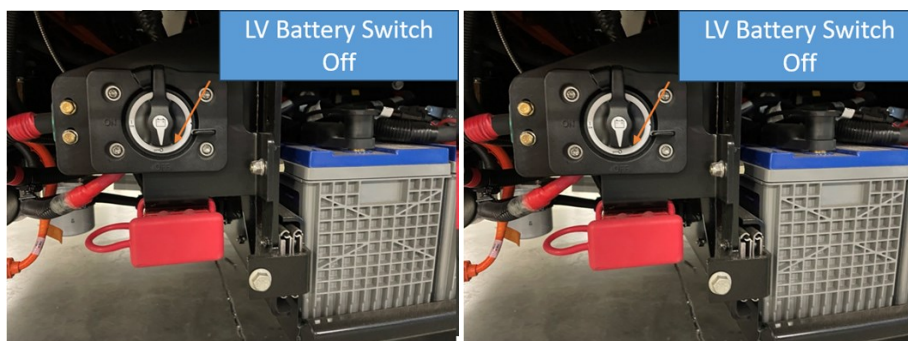

## MVP DASH SOFTWARE UPDATE PROCEDURE

### Step 62:

Ensure you have the latest software file “066144\_MVP12\_Flashing\_v5.3.0.MVP12\_A” downloaded to your local machine.

### Step 63:

Turn the vehicle on at the rear both the battery saver switch and master disconnect to ON.

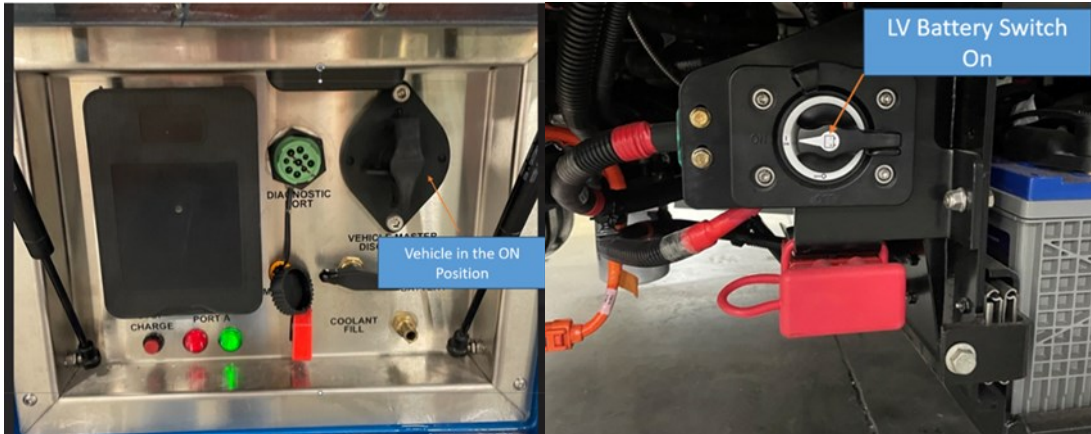

### Step 64:

Set the Master Switch to OFF and Hazard Switch to ON.



### Step 65:

Boot up the PDT and attach the Nexiq in the following configuration at the rear deck.

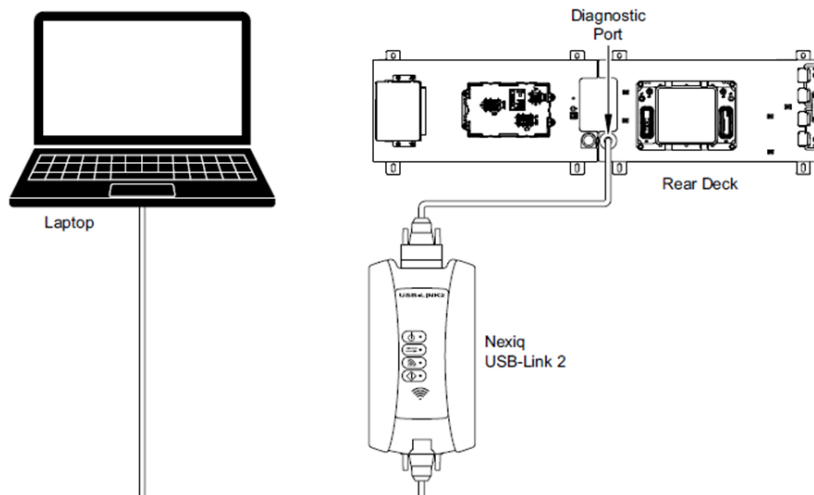

## Step 66:

Once the PDT is launched navigate to the “Dash Config” tab.

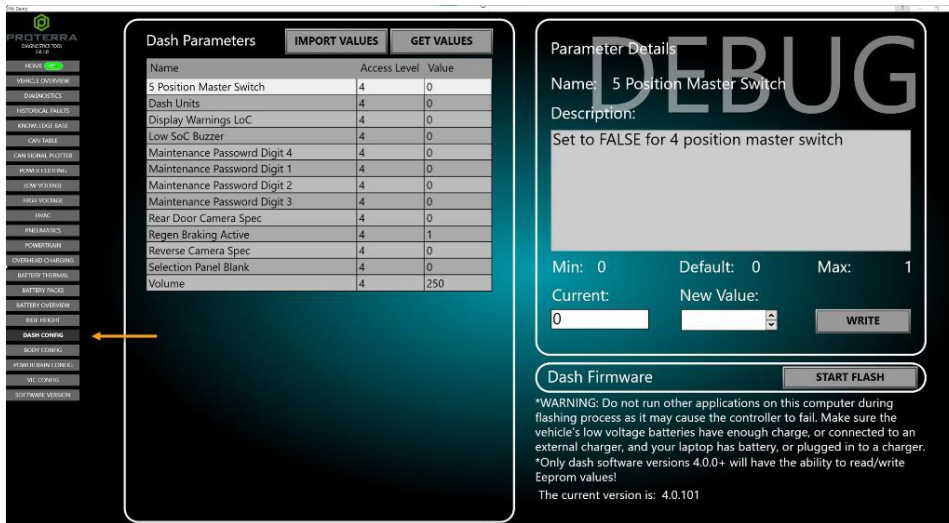

## Step 67:

Select the Dash Firmware “Start Flash” icon.



## Step 68:

When prompted select the file “066144\_MVP12\_Flashing\_v5.3.0.MVP12\_A” from your hard drive.

## Step 69:

Once you get the pop up below, turn on the working light in the SSWB. Select “OK”. Software update is complete.

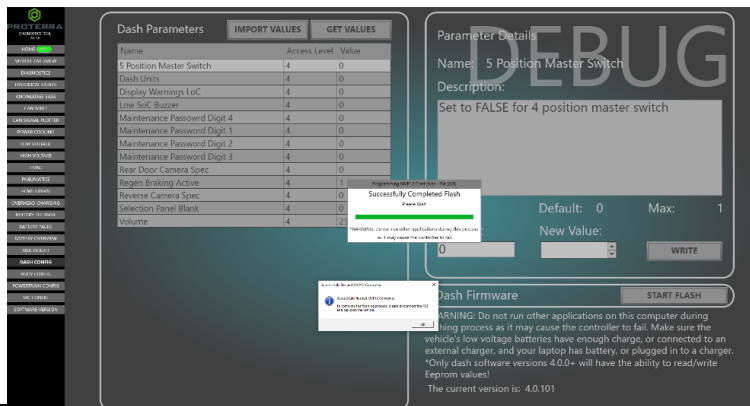

## Step 70:

Power down the bus at the Curbside Rear of the vehicle and at the Battery Saver Switch.

Close PDT.

# **Proterra EV Battery Fire Safety Guide**

## **Thermal Event Diagnostics, Prevention & Response**

### **LEGAL DISCLAIMER**

#### **PLEASE READ**

**This document provides general guidance to the owner/customer (“Owner”) to develop its own safe work procedures related to Proterra’s electric vehicle and electric vehicle battery pack (individually and collectively, the “Product”). Any reference to standards, regulations or laws is not exhaustive, nor intended to advise the Owner of its legal duties or compliance obligations.**

**This document is not based on a specific Product configuration. Proterra assumes that all who purchase the Product have expertise to properly and safely receive, handle, store, use, and service the Product. Accordingly, this document is intended as a helpful supplement for the Owner and not a substitute for the Owner’s expertise or responsibility regarding these topics. If any Owner lacks such expertise or does not agree to the foregoing limited purpose, such Owner should immediately notify Proterra in writing and should not procure, take delivery of, or use the Product.**

**This document is provided “as is,” and Proterra assumes no liability or responsibility for any loss, damage or expense resulting from the Owner’s, or any agent or affiliate of the Owner’s, reliance upon, or use of, this document. Proterra makes no warranty or representation, and expressly disclaims any such warranties or representations, that the content of this document is complete, accurate, reliable or error free, to the fullest extent permitted by applicable law. Each Owner assumes the entire risk as to its reliance upon, or use of, this document. Proterra is not responsible to update the content of this document at any time, including based on changes, combinations, or conversions of the Product.**

# 1 FIRE-SAFETY GUIDELINES FOR AN EV BATTERY

---

- a) In the event there is a battery fire, immediately stop operating or working in/around the vehicle. All individuals should move *at least* twenty feet away from the vehicle.
- b) Immediately call the local emergency number (e.g., “911”) to report the battery fire and ask for assistance from fire, police, and medical departments. See First Responder Guide below.
- c) It requires specialized training and personal protective equipment (“PPE”) to safely extinguish a battery fire. The Owner should establish a site-specific safety plan related to EV vehicles and all on-site first responders should be trained to execute the safety plan. The safety-plan should take the following factors into consideration:
  - i) A battery fire may require application of **large amounts of water** to the battery pack for a **long period of time** from a **safe distance** to extinguish a battery fire.

**Do not:**

- Stand close to the vehicle while attempting to extinguish a battery fire.
  - Attempt to open a battery pack for purposes of cooling it with water.
  - Attempt to extinguish a battery fire with a small, limited quantity of water.
  - Use an “ABC” rated fire extinguisher to put out a battery fire.
- ii) **Always** wear the appropriate PPE, including full body covering fire-fighting clothing and self-contained breathing apparatus. Hot metals may be ejected from the battery during a fire, and materials contained inside the battery pack are flammable, corrosive, and should not be inhaled or allowed to contact the eyes or skin.
  - iii) The battery pack may vent hot gases composed of volatile organic compounds such as alkyl-carbonates, methane, ethylene, and ethane, as well as hydrogen gas, carbon dioxide, carbon monoxide, soot, and particulates containing oxides of nickel, aluminum, lithium, copper, and cobalt. Vented gas temperatures may exceed 600°C. The gases may cause burns upon contact. The gases may ignite unexpectedly creating a fire or explosion.
  - iv) Battery pack fires may require up to 24 hours to extinguish. It may be necessary to allow the battery pack to burn while protecting structures or other objects in the vicinity. When all smoke and fire has visibly subsided and cleared, a thermal imaging camera should be used to actively measure the temperature of the high voltage battery and monitor temperature trends — i.e., is the battery consistently cooling down over time, or is it heating up again?
  - v) The battery pack must be completely cooled and there must not be fire, smoke, or heat present in the high voltage battery for at least one hour before the vehicle can be released to second responders (such as vehicle transporters). Second responders must be advised that

there is a risk of battery pack re-ignition. Damaged high voltage lithium ion batteries require special transportation measures, and therefore are prohibited from regular transportation.

- vi) Do not contact any high voltage components and always use insulated tools during overhaul.
- vii) A battery fire may damage the vehicle's airbag inflators, stored gas inflation cylinders, gas struts, and other components which can result in an unexpected explosion. A full "knock down" procedure should be performed.

d) First Aid Measures

- i) **Electric Shock/Electrocution:** Seek immediate medical attention (suspected or confirmed); call 911.
- ii) **Contact with Leaked Material (Electrolyte, Coolant):** The contents of an open or broken constituent battery cell may cause skin irritation and/or chemical burns. In the event of contact, immediately flush skin with water and wash affected area with soap/water. Seek immediate medical attention if a burn or other irritation does not resolve. For eye contact, immediately flush with a significant amount of water for at least 15 minutes without rubbing and seek immediate medical attention; call 911.
- iii) **Vapor or Gas Inhalation (Electrolyte Vapor, Vent Gas):** Immediately move to fresh air source. If not breathing, perform artificial respiration and call 911.

## 2 FIRST RESPONDER GUIDE

Information for first responders to respond to a battery fire involving an electric vehicle can be found at the National Fire Protection Association website:

<https://www.nfpa.org/Training-and-Events/By-topic/Alternative-Fuel-Vehicle-Safety-Training/Emergency-Response-Guides/Proterra>

A sample of the information for first responders located at this website is shown below for reference. First responders may also contact Proterra at [service@proterra.com](mailto:service@proterra.com) if they have any questions.

If a fire develops, the Incident Commander should determine whether an attempt will be made to suppress the fire (aggressive firefighting) or allow the battery pack to burn until it self extinguishes, while protecting surrounding materials (defensive firefighting). Establish a 20 foot radius "safety zone" around the vehicle.

Virtually all fires involving lithium-ion batteries can be controlled with water. To date, water has been found to be the most effective agent for controlling lithium-ion battery fires. Water will suppress flames and can cool cells, limiting propagation of thermal runaway reactions. If water is used, electrolysis of water (splitting of water into hydrogen and oxygen) may contribute to the flammable gas mixture formed by venting cells, burning plastic, and burning of other combustibles. Thus copious volumes of water should be used to fight a lithium-ion battery fire.

Gaseous agents such as CO<sub>2</sub> or Halon, or dry chemical suppressants may temporarily suppress flaming of lithium-ion battery packs, but they will not cool lithium-ion batteries and will not limit the propagation of cell thermal runaway reactions. Metal fire suppressants such as LITH-X, graphite powder, or copper powder are not appropriate agents for suppressing fires involving lithium-ion battery packs as they are unlikely to be effective.

A battery fire may continue for several hours and it may take 24 hours or longer for the battery pack to cool. A lithium-ion battery fire that has been extinguished can re-ignite due to the exothermic reaction of constituent materials from broken or damaged cells. To avoid this, remove sources of ignition and cool the burned mass by flooding with water.

 **When fire is present, always wear appropriate PPE, including self-contained breathing apparatus.**

**NOTE: Direct hose streams toward the outside edge of the battery packs as shown in the diagram below. Apply copious amounts of water.**

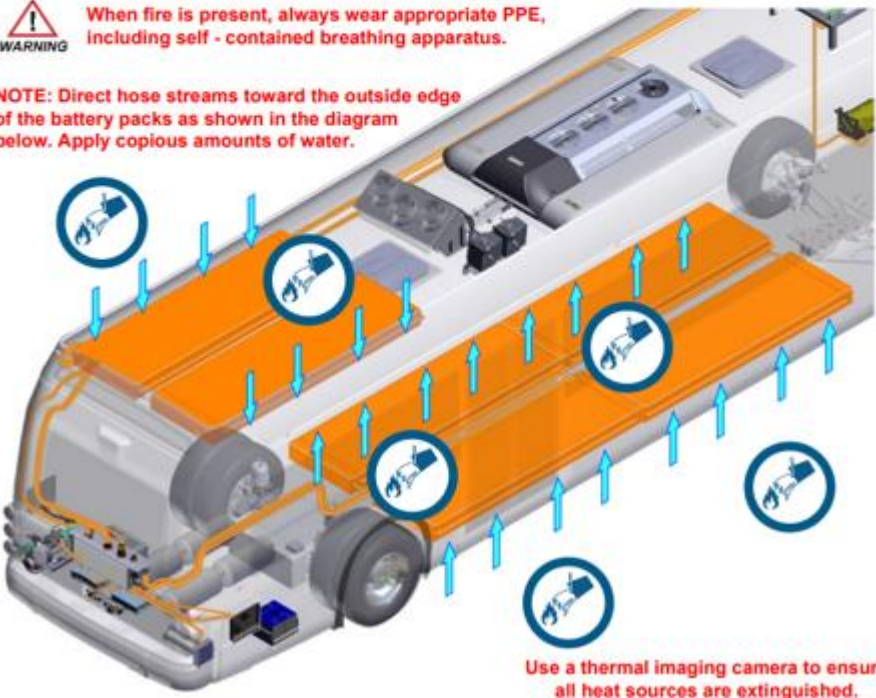

**Use a thermal imaging camera to ensure all heat sources are extinguished.**

## 3 BACKGROUND

---

### 3.1 THERMAL EVENT VS. THERMAL RUNAWAY.

Each Proterra battery consists of multiple battery cells. Proterra’s diagnostic system is set up to detect a battery “thermal event” where a single battery cell fails in a manner that may cause an unintended chemical reaction to occur inside the cell. The battery pack is designed to contain a single battery cell “thermal event” and prevent a “thermal runaway” (or fire) that involves neighboring battery cells. A “thermal runaway” may occur if other abnormal conditions exist such that the single cell “thermal event” is not contained (e.g., physical impact that causes significant damage to the battery pack). A “thermal runaway” is detectable by smoke, a burning smell, a flame, and other indications of a fire.

If there are any signs that the battery pack may be experiencing a “thermal runaway,” or fire (e.g. smoke, a burning smell, abnormal popping or whistling noises, a flame, etc.), then you must immediately discontinue use of the vehicle and follow the emergency guidelines outlined in the above Fire-Safety Guidelines for an EV Battery.

### 3.2 DIAGNOSTICS, DRIVER NOTIFICATION & VEHICLE RESPONSE

Proterra vehicles have battery sensors and diagnostics used to detect signals related to temperature, humidity, internal pack air pressure and isolation. If an abnormal battery condition is detected, Proterra’s diagnostic system will transmit a message on the vehicle CAN bus. This information will be communicated to the driver via the vehicle dash as described below.

Critical battery faults which indicate the potential for a thermal event will result in a Fast Flash Red Stop Lamp in the vehicle dash that blinks at a rate of two times per second, and an audible alarm that pulses twice per second (collectively, the “Critical Battery Fault Warnings”). *Critical Battery Fault Warnings indicate a critical battery failure which could result in a thermal event.* When the Critical Battery Fault Warnings are active, please immediately follow the procedures set forth in the Operator/Driver Guidelines section below, as well as the instructions in any applicable sections of the Proterra Driver’s manual.

For any other types of driver’s dash display warning lights (including but not limited to solid, non-flashing red or yellow “warning” lights) and/or audible alarms, please refer to the vehicle owner’s manual for an explanation of these warnings and recommended actions.

Figure 1 below shows the Red Stop Lamp as presented on the original Proterra dash. Figure 2 below shows the Red Stop Lamp as presented on the updated Proterra digital dash.

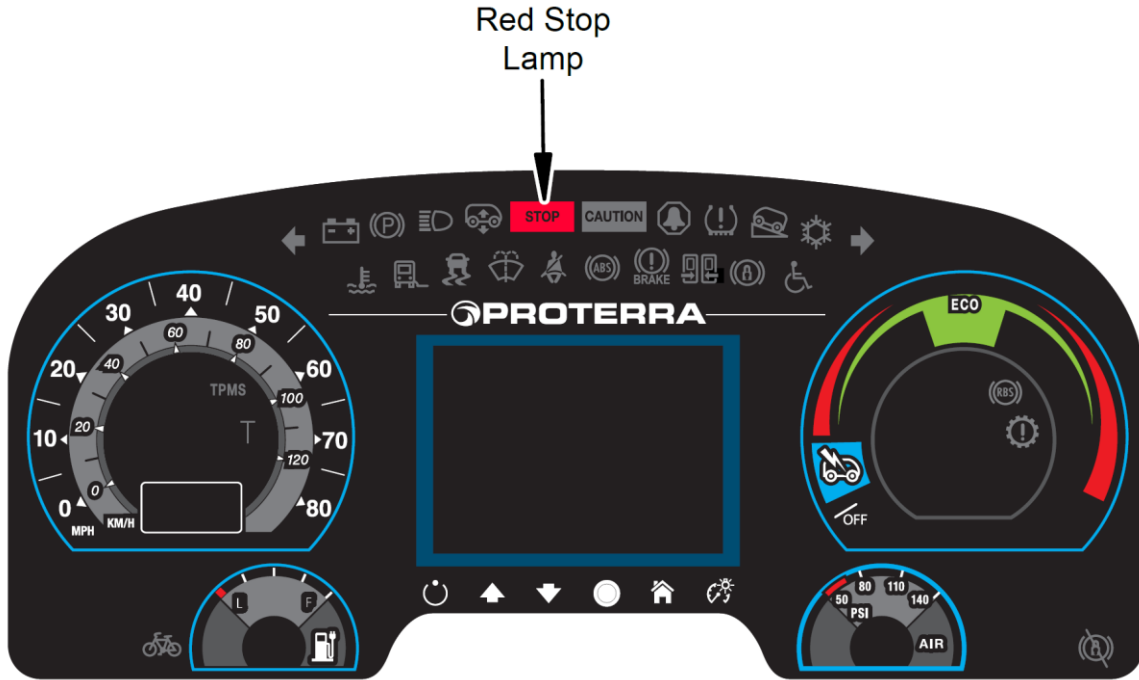

Figure 1 – Red Stop Lamp on Original Dash

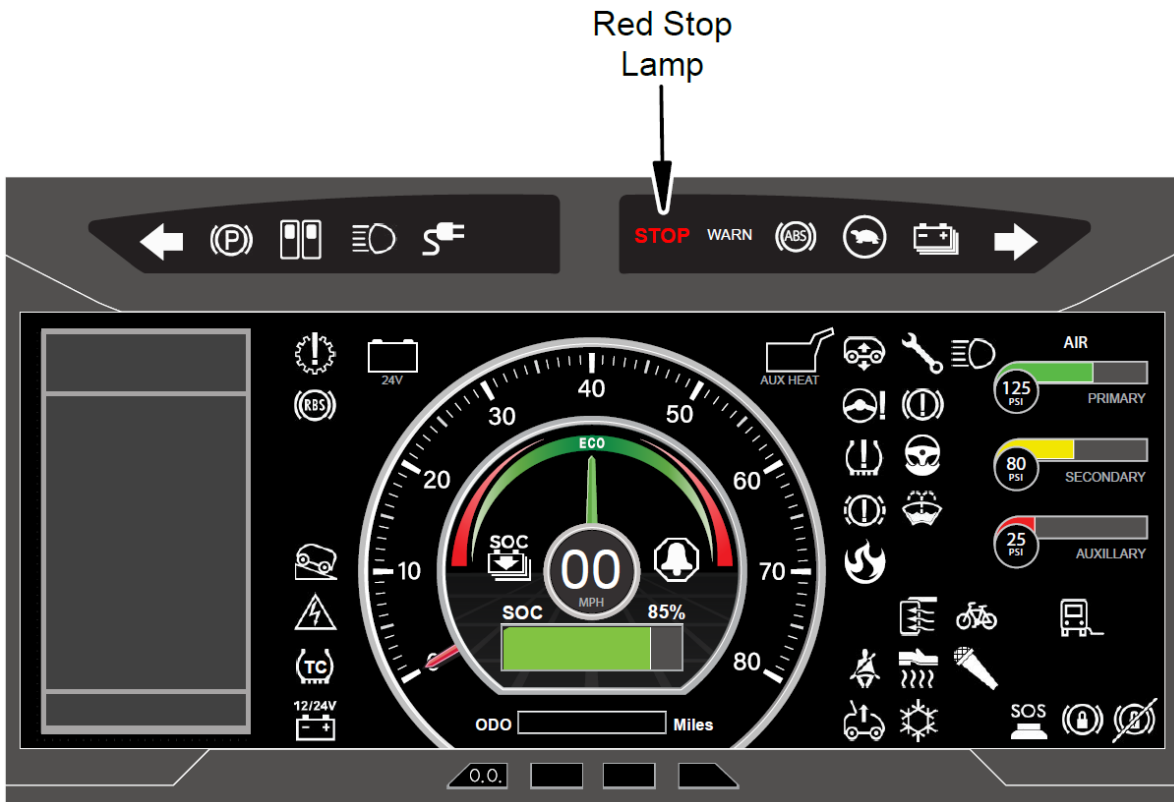

Figure 2 – Red Stop Lamp on Digital Dash

**OWNERS SHOULD ALWAYS MONITOR AND RESPOND TO DASH FAULT LIGHTS AS PART OF THE VEHICLE OPERATION AND MAINTENANCE ROUTINE. OWNERS MUST PERFORM FOLLOW-UP INVESTIGATION WHEN DASH FAULT LIGHTS PRESENT. DO NOT IGNORE A DASH FAULT LIGHT.**

In addition to the Critical Battery Fault Warnings, a critical battery fault will prevent the vehicle from charging and cause the vehicle to immediately enter a “limp home” state where the propulsion system is limited to 50 kW. The “limp home” state will provide enough power to launch the vehicle and maintain 35 mph on a flat road with an unloaded bus. In addition to the Critical Battery Fault Warnings, the Owner’s service technicians should be trained by Proterra in use of Proterra’s diagnostic tool to identify and detect abnormal battery conditions (see <https://www.proterra.com/proterra-diagnostics-tool/> to download the tool and access training material). The Owner’s consistent and routine use of the Proterra diagnostic tool is recommended to identify and monitor issues that may require further investigation.

## 4 OPERATOR/DRIVER GUIDELINES

---

Prior to operating the vehicle, the driver must perform all recommended safety checks set forth in the Proterra Driver's Manual. This inspection includes, but is not limited to, a visual inspection for signs of damage/malfunction and confirmation that the fault lights in the dashboard display are not illuminated.

If there are any signs of fire prior to operation or while the vehicle is in use (e.g., smoke, a burning smell, abnormal popping or whistling noises, a flame, etc.), the driver must immediately stop the vehicle in a safe location and evacuate all passengers in accordance with the emergency guidelines in Fire-Safety Guidelines for an EV Battery (Section 1). Note -- the vehicle may be in a "limp home" state with limited propulsion as described above.

If the Critical Battery Fault Warnings are active as described in Section 3.2 (but there is no smoke, burning smell, abnormal popping or whistling noises, flame, etc.), the vehicle should be promptly parked in a safe outdoor location at least 20 feet away from other objects such as buildings, trees and other vehicles, and at least 100 feet away from highly flammable items such as gas stations or propane tanks. Once the vehicle has been moved to a safe location, the operator and passengers may exit the vehicle and the vehicle should be removed from service.

The vehicle high voltage system may be left in either state; on or turned off. However, DO NOT open the 12/24 Master Disconnect Switch or Battery Saver Switch (if equipped). Keeping these switches closed will allow the battery coolant pumps to operate as intended to mitigate heat buildup as well as providing power to telemetry systems for remote data review.

### Next Steps

- Call the Proterra Regional Field Service Representative (FSR) as soon as possible to report the issue. Proterra will respond within 2 hours (Mon- Fri between 6 am-6pm ET) or by 9 AM ET the following business day.
- DO NOT attempt to charge the vehicle.
- Continue to monitor the vehicle for signs that there could be a thermal runaway (smoke, burning smell, abnormal popping or whistling noises, flame, etc.).
- DO NOT operate or work on the vehicle until Proterra's service personnel have had the opportunity to assess the situation and the parties have an agreed action plan.  
If there are any signs of a fire (e.g., smoke, a burning smell, abnormal popping or whistling noises, a flame, etc.), follow the emergency guidelines outlined in Fire-Safety Guidelines for an EV Battery (Section 1).

## 5 MONITORING BATTERIES WITH DIAGNOSTIC TOOL

---

The Proterra Diagnostic Tool (the "Diagnostic Tool") enables customers to monitor the humidity and isolation levels of a battery pack that may indicate a critical battery safety condition. These metrics are used by the software systems described above. **As part of a customer's routine maintenance program, the Diagnostic Tool should be used every *three months* to monitor the humidity and internal isolation levels of each battery pack as described below. If a vehicle has been turned off for three months or**

more, the customer must use the Diagnostic Tool to check each battery pack *prior to* starting, operating or charging the vehicle.

### Steps to Use Diagnostic Tool to Check Humidity and Internal Isolation of Battery Packs

**Step 1:** Connect the Diagnostic tool to a vehicle diagnostic port that has BCAN access. NOTE: The diagnostic port location varies based on the vintage of the vehicle.

**Step 2:** View the “Battery Thermal” screen on the left-hand side. Example:

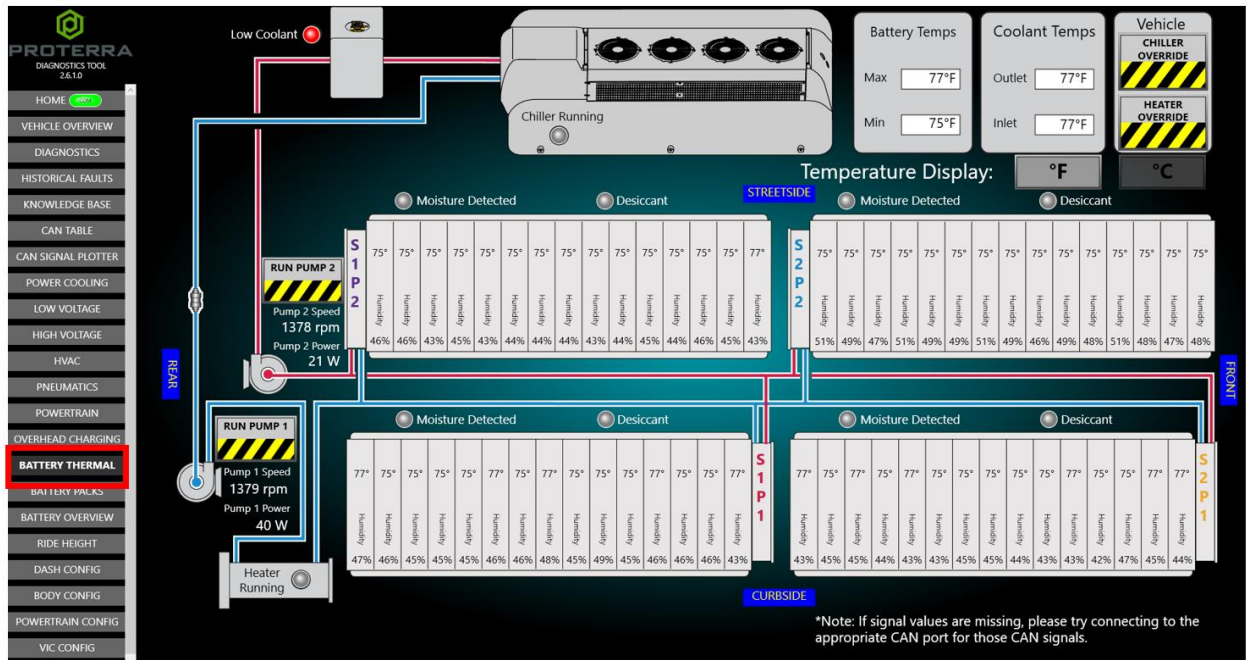

**Step 3:** View the humidity level of each module per battery pack; the pack ID is located on the graphic of the A-Bay. If the module humidity levels are less than 70%, the battery pack check is complete. If there is one or more module(s) that exceeds 70% humidity, you must proceed to the next step.

**Example:** S1P1, S1P2, S2P1 and S2P2 as shown below. NOTE: your screen and Pack ID may look different based on the vintage of vehicle.



**Step 5:** With the relevant Pack ID selected in the pulldown menu, the internal isolation value should be recorded.

The screenshot shows the Proterra Diagnostics Tool interface. The 'Isolation Internal' value is highlighted in red as 47640 kΩ. Other displayed values include Pack Voltage: 324.90 V, Pack Current: -13.80 A, Coolant Supply Temp: 50°F, and Coolant Return Temp: 50°F. The interface also shows a sidebar menu with options like HOME, VEHICLE OVERVIEW, DIAGNOSTICS, HISTORICAL FAULTS, KNOWLEDGE BASE, CAN TABLE, CAN SIGNAL PLOTTER, POWER COOLING, LOW VOLTAGE, HIGH VOLTAGE, HVAC, PNEUMATICS, POWERTRAIN, OVERHEAD CHARGING, BATTERY THERMAL, BATTERY PACKS, BATTERY OVERVIEW, RIDE HEIGHT, DASH CONFIG, BODY CONFIG, POWERTRAIN CONFIG, and VIC CONFIG. A table of battery cell voltages is displayed, with all values in volts.

75°	75°	75°	75°	75°	75°	75°	75°	75°	75°	75°	75°	75°	75°	75°
3.586	3.586	3.585	3.586	3.585	3.585	3.585	3.585	3.585	3.586	3.585	3.585	3.586	3.585	3.585
3.586	3.587	3.586	3.586	3.586	3.586	3.585	3.585	3.585	3.586	3.585	3.586	3.585	3.585	3.585
3.585	3.586	3.585	3.585	3.585	3.583	3.585	3.585	3.585	3.586	3.585	3.585	3.586	3.585	3.583
3.585	3.586	3.586	3.586	3.585	3.585	3.586	3.585	3.585	3.585	3.585	3.586	3.585	3.583	3.586
3.585	3.586	3.586	3.586	3.586	3.585	3.585	3.585	3.585	3.586	3.585	3.586	3.585	3.586	3.586
3.584	3.585	3.585	3.585	3.584	3.585	3.585	3.583	3.585	3.585	3.585	3.585	3.585	3.586	3.585

\*Note: If signal values are missing, please try connecting to the appropriate CAN port for those CAN signals. \* All battery values are shown in volts

**Step 6:** If either of the following conditions are met, proceed to [Step 7](#) below.

- a. Condition 1:
  - Humidity greater than 90%
- b. Condition 2:
  - Humidity greater than 70% AND
  - Internal Isolation less than 20,000 Kohms

If neither of these conditions are met, no issue has been found with respect to the recorded battery pack(s) humidity and internal isolation levels, and the battery pack check is complete.

**Step 7: If Condition 1 or 2 are present:**

The vehicle should be promptly parked in a safe outdoor location at least 20 feet away from other objects such as buildings, trees and other vehicles, and at least 100 feet away from highly flammable items such as gas stations or propane tanks. Once the vehicle has been moved to a safe location, the operator and passengers may exit the vehicle and the vehicle should be removed from service.

The vehicle high voltage system may be left in either state; on or turned off. However, DO NOT open the 12/24 Master Disconnect Switch or Battery Saver Switch (if equipped). Keeping these switches closed will allow the battery coolant pumps to operate as intended to mitigate heat buildup as well as providing power to telemetry systems for remote data review.

- Call the Proterra Regional Field Service Representative (FSR) as soon as possible to report the issue. Proterra will respond within 2 hours (Mon- Fri between 6 am-6pm ET) or by 9 AM ET the following business day.
- DO NOT attempt to charge the vehicle.
- Continue to monitor the vehicle for signs that there could be a thermal runaway (smoke, burning smell, abnormal popping or whistling noises, flame, etc.).
- DO NOT operate or work on the vehicle until Proterra’s service personnel have had the opportunity to assess the situation and the parties have an agreed action plan.

If there are any signs of a fire (e.g., smoke, a burning smell, abnormal popping or whistling noises, a flame, etc.), follow the emergency guidelines outlined in Fire-Safety Guidelines for an EV Battery (Section 1).