

01/29/2025
CAL FTL 13-003

Subject: 114SD's Ordered with 2-Cylinder Air Compressors Delivered Without Pressure Relief Valve

Make: Freightliner

Model: Business Class M2 and 114SD

Model Year Affected: 2024-2025

Build Date Range: Selected Vehicles Built Between October 14th, 2023 & January 11th, 2025.

Our records indicate that you are the owner of certain vehicles; therefore, DTNA has decided to share the following documentation with you.

Please see the attached communication in this email. We hope you find this information helpful.

01/29/2025
CAL FTL 13-003

General Information

1. Park the vehicle on a level surface, shut down the engine, and set the parking brake. Chock the tires.
2. [Figure 1](#), module 131, shows the 2-cylinder air compressor (grey color) with the correct pressure relief valve (Ref ST1), Tee (Ref CMB), and adapter (Ref CMA).

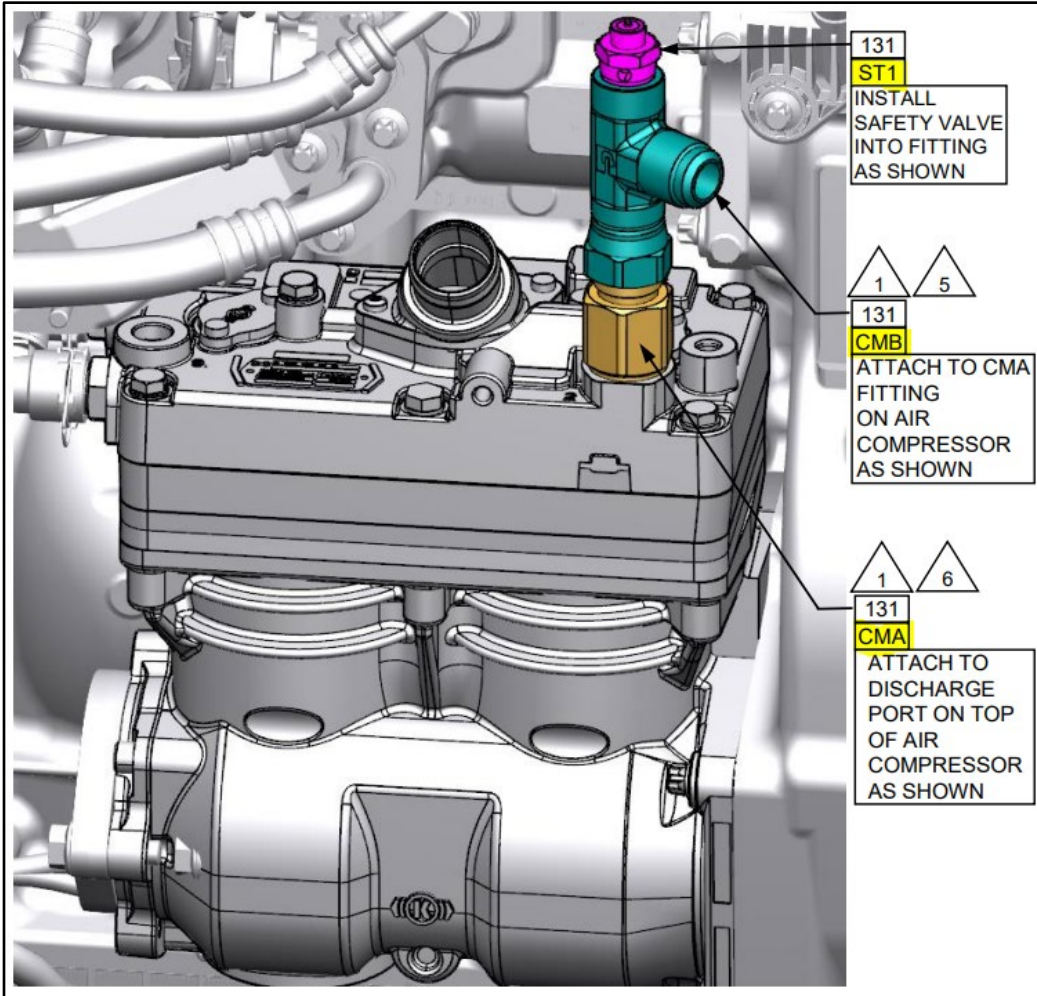

Fig. 1 Safety Valve, Fitting and Discharge Port

3. See [figure 2](#) for adapter (Ref ADP), module 480.

01/29/2025
CAL FTL 13-003

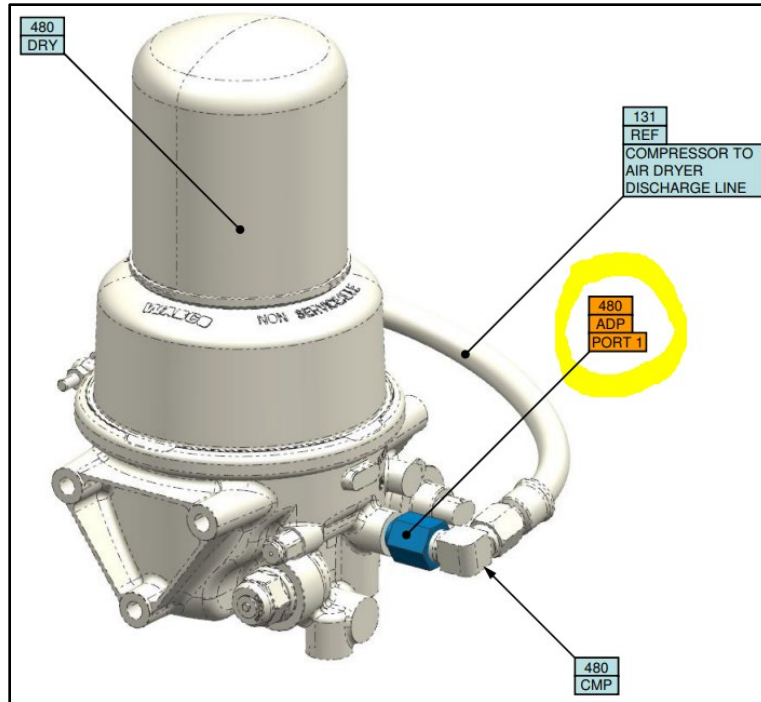

Fig. 2 Adapter

- See [Table 1](#) for the list of serial numbers that require updating with the correct 2-cylinder air compressor discharge BOM, the new module 480 fitting, and the responsible DSM.

SERIAL	NEW 2CYL BOM	ADDITIONAL NEW ADAPTER (REF ADP) MODULE 480	# OF UNITS	CUSTOMER	Dealer	DSM
VB1667	131-C19945	210502 000046	1	GARDEN STATE	NORTH JERSEY TRUCK CENTER, INC 236 ROUTE 46 EAST SADDLE BROOK NJ	Jason Grobble
VB1668	131-C19945	210502 000046	1	GARDEN STATE	NORTH JERSEY TRUCK CENTER, INC 236 ROUTE 46 EAST SADDLE BROOK NJ	Jason Grobble
VC0102	131-C19953	210502 000046	1	COMMERCIAL T	NEW WEST TRUCK CENTRES 5925 79TH AVENUE S.E. CALGARY AB Zip:	Shawn Evoy
VG2631	131-C19953	210502 000046	1	CARCO INDUST	FREIGHTLINER NORTHWEST 90975 ROBERTS ROAD COBURG	Shawn Pham
VG2632	131-C19953	210502 000046	1	CARCO INDUST	FREIGHTLINER NORTHWEST 90975 ROBERTS ROAD COBURG	Shawn Pham
VG3611	131-C19932	210502 000046	4	SUMMIT MATER	PREM TRUCK GRP OF SALT LAKE CI 2240 SOUTH 5370 WEST SALT LAKE CITY UT	Nahum Veach
VH1866	131-C19937	210502 000046	1	PRO GRO MIXE	PREMIER TRUCK GROUP OF SALEM 4060 INTERSTATE PLACE NE SALEM	Shawn Pham
VP6821	131-C19932	210502 000046	4	SUMMIT MATER	PREM TRUCK GRP OF SALT LAKE CI 2240 SOUTH 5370 WEST SALT LAKE CITY UT	Nahum Veach
VP6825	131-C19932	210502 000046	2	SUMMIT MATER	PREM TRUCK GRP OF SALT LAKE CI 2240 SOUTH 5370 WEST SALT LAKE CITY UT	Nahum Veach
WG8035	131-C19953	210502 000046	1	LONESTAR TRUCK GROUP TEMPLE	LONESTAR TRUCK GROUP TEMPLE	Jacob Brewer

Table 1. Serial Number, BOM and Responsible DSM