



PROTERRA



FLEET CHECK

ISSUE DATE:	6/23/2022
SERVICE BULLETIN SUBJECT:	VROD Bracket Securement Inspection
VINs or MODELS AFFECTED:	Service Specified Buses
COMPLETE BY:	Next Service Opportunity
SERVICE BULLETIN #:	FC-22-75
LABOR OPERATION CODE:	SR42Z

NOTICE! It is expected that this process may require up to one hour per bus. Please schedule appropriately to minimize vehicle downtime.

VROD BRACKET SECUREMENT RETROFIT

Description

This procedure describes the process of inspecting the VROD Bracket for proper securement.

Tools/Parts Required

Tools and Supplies Required:

- Ratchet
- Socket Set
- TOOL, FEELER GAUGE, .04-1MM, 25 FEATHERS (061913)
- Calibrated Torque Wrench
- Orange Torque Stripe Paint

Kit Parts Required:

- 013573-006 BOLT, HEX, FLG, STL,1000HSS, CLASS10.9, M16-2.0X50X50 TBD

4. Using the following illustrations as a guide, take a photograph of each area of the bus.

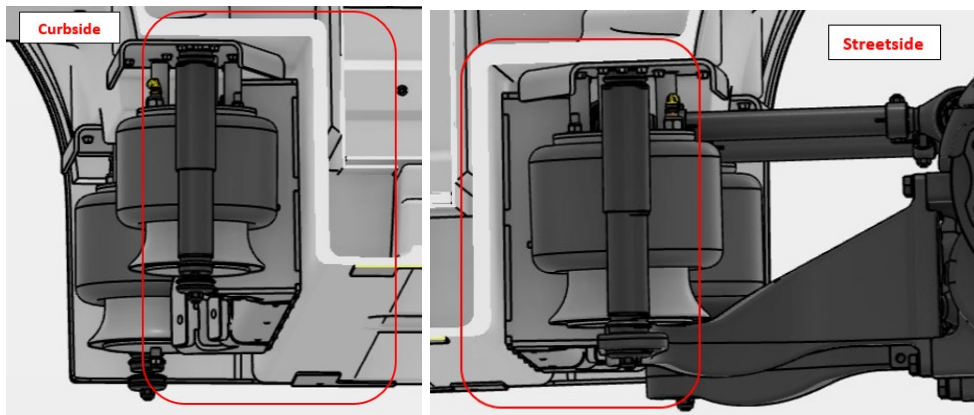
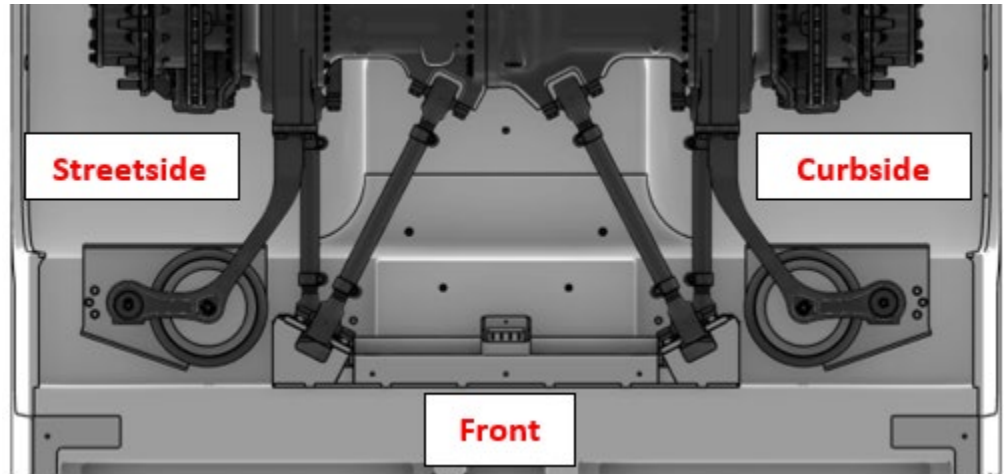

5. Using the following illustration as a guide, inspect the torque stripes on the suspension link bracket bolts.

