



---

## FIELD SERVICE CAMPAIGN – 24111R1

09 December 2024

---

### SUBJECT:

Coolant hose reroute for the cabin heater.

### MODELS INVOLVED:

IC Bus® Electric CE Series buses.

### REASON FOR REVISION:

Added section and parts for heat exchangers with shutoff valve (feature 48PPP). Added image showing correct installation of parts for the overall cabin heater system. Revised steps and images throughout the document for consistency and clarity.

### DEFECT DESCRIPTION:

Certain IC Bus® Electric CE Series buses may have incorrect coolant hose routing for the cabin heat which may cause coolant to leak from the cabin heat surge tank overflow hose.

### ELIGIBILITY:

This procedure applies ONLY to vehicles marked in the International® Service Portal<sup>SM</sup> with FSC 24111. Also complete any other open campaigns listed on the Service Portal at this time.

### TOOLS REQUIRED:

Description	Tool Number
Coolant Management Tool	KL5007NAV
Cooling System Adapter	09-040-03
High-Voltage Personal Protective Equipment (PPE) including Class 0 electrical insulating gloves (Red Label), Electrical Hazard (EH) rated safety shoes / boots, flame resistant clothing, and face shield	N/A

**Table 1** Tools Information

**PARTS REQUIRED:**

Part Number	Part Description	Quantity
8900381R91	Kit, Cabin Heat Plumbing	1
N/A	1 x 5/8-in Adapter (source locally)	2

**Table 2** Parts Information

**8900381R91** contains the following parts:

Item	Part Number	Part Description	Length / Quantity
1	L2643485	Hose, Heater, 5/8-in ID Premium	18.3-in (465 mm)
2	3817028C1	Hose, Heater, Bus Body	1
3	L2643493	Hose, Heater, 1-in ID Premium	2.95-in (75 mm)* 9.84-in (250 mm)**
4	4310950C1	T-fitting, 1 x 1 x 5/8 in	2
5	L2643493	Hose, Heater, 1-in ID Premium	2.4-in (61 mm)* 5.15-in (131 mm)**
6	L2643493	Hose, Heater, 1-in ID Premium	49.2-in (1250 mm)* 65.0-in (1651 mm)**
7	4421530C1	Hose, Heater, PSGR 90-degree 5/8 in	1
8	3878141C1	Adapter, Double 5/8-in Hose Barb	1
9	2643485R1	Hose, Heater, 5/8-in ID Premium	49.7-in (1263 mm)
10	1622034C1	Clamp, Air Duct Hose, 0.81–1.50-in	10
11	1514759C1	Clamp, Rad Inlet Hose, 13/16–1-1/16-in	6
* Hose length for vehicle with shutoff valve (feature 48PPP).			
** Hose length for vehicle without shutoff valve.			

**NOTE: Hoses in the kit will need to be cut to size as required in each step.**

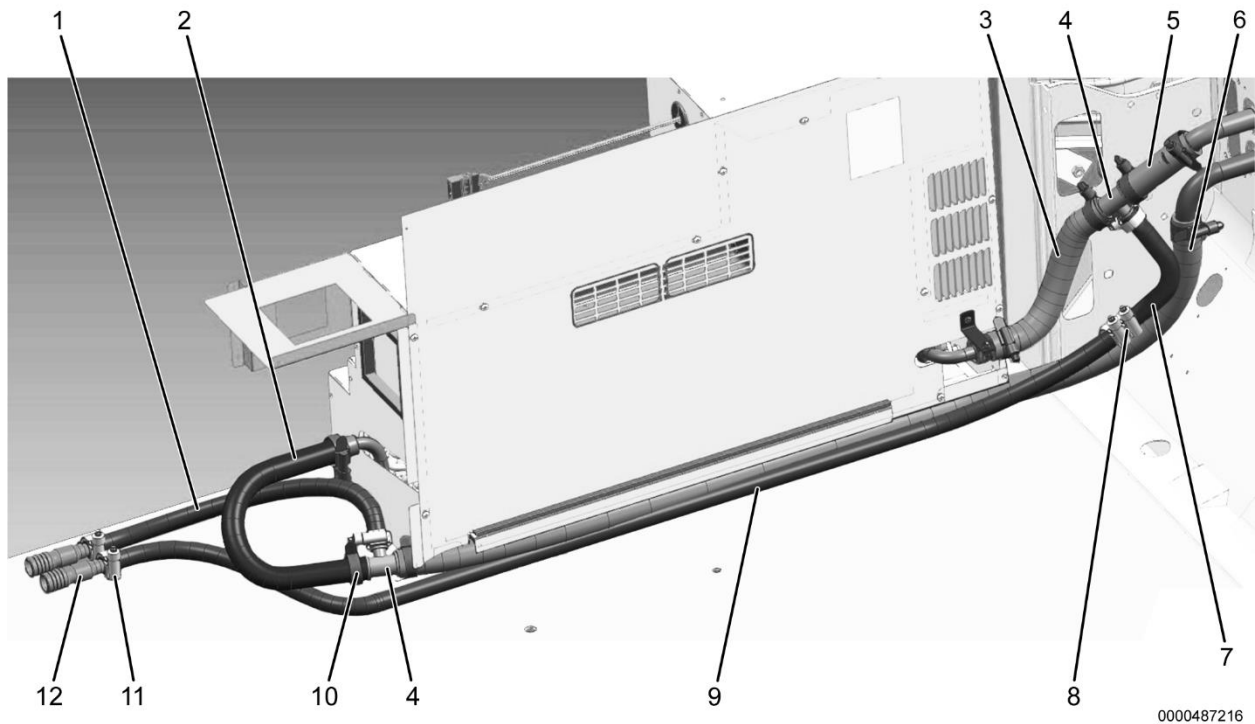

Figure 1. Driver Heater Hose Parts (Configuration Without Shutoff Valve Shown)

## WORK INSTRUCTIONS

**GOVERNMENT REGULATION:** Engine fluid (oil, fuel, and coolant) may be a hazard to human health and the environment. Handle all fluid and other contaminated materials (such as filters and rags) in accordance with applicable regulations. Recycle or dispose of engine fluids, filters, and other contaminated materials according to applicable regulations.

**WARNING!** To prevent personal injury and / or death, or damage to property, park vehicle on hard flat surface, turn the engine off, set the parking brake, and install wheel chocks to prevent the vehicle from moving in both directions.

**WARNING!** To prevent personal injury and / or death, always wear safe eye protection when performing vehicle maintenance.

**WARNING!** To prevent personal injury and / or death, or damage to property, keep flames or sparks away from vehicle and do not smoke while servicing the vehicle's batteries. Batteries expel explosive gases.

**WARNING!** To prevent personal injury and / or death, or damage to property, remove the ground cable from the negative terminal of the battery before disconnecting any electrical components. Always connect the ground cable last.

**WARNING!** To prevent personal injury and / or death, wear and use approved high-voltage Personal Protective Equipment (PPE) when near a high-voltage electric vehicle. Inspect PPE before use. Do not use gloves or other PPE with expired dates, holes, cracks, or damage. NEVER touch energized ORANGE high-voltage cables or high-voltage components without wearing approved high-voltage PPE.

**WARNING!** To prevent personal injury and / or death, read all information in the Safety Information and High-Voltage Safety sections of the service manual.

1. Park vehicle on a dry, level surface.
2. Put drive mode selector in Park or Neutral and set parking brake.
3. Turn ignition to Key OFF position.
4. Install wheel chocks.
5. Turn 12V disconnect switch OFF.
6. Perform High-Voltage Isolation Level 1. Refer to appropriate service manual for detailed procedure.
7. Perform coolant drain procedure on the cabin heater coolant system. Refer to appropriate service manual for detailed procedure.
8. Remove the driver heat exchanger trim and closeout panels to gain access to the cabin heat supply and return hoses. Make note of which hose is supply and return connecting to the underseat heater.
9. Check if the the hoses at the front of the heat exchanger have a shutoff valve (feature 48PPP).
  - a. Yes: Continue to Step 10. See *Replacing and Routing Supply Hoses at Front of Heat Exchanger (WITH Shutoff Valve, Feature 48PPP)*.
  - b. No: Proceed to Step 21. See *Replacing and Routing Supply Hoses at Front of Heat Exchanger (WITHOUT Shutoff Valve)*.

## Replacing and Routing Supply Hoses at Front of Heat Exchanger (WITH Shutoff Valve, Feature 48PPP):

Perform the following steps for buses with a shutoff valve near the front of the heat exchanger (feature 48PPP).

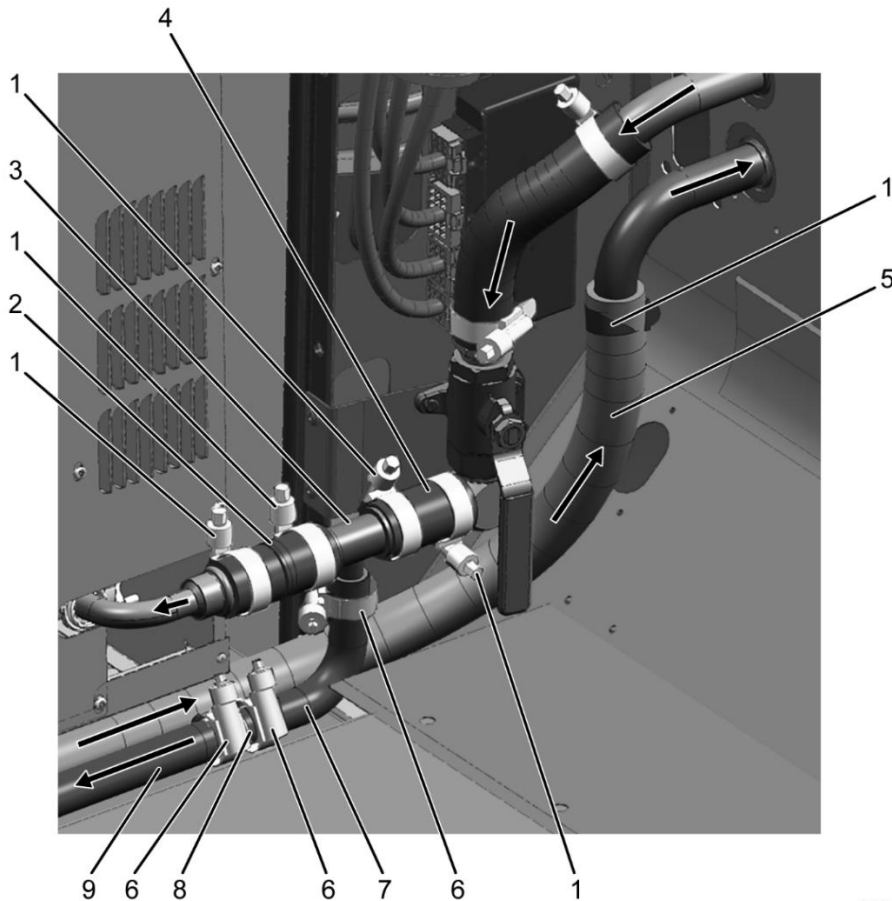

0000486848

**Figure 2. Hose Routing (Front of Heat Exchanger With Shutoff Valve)**

1. 1-in clamp
2. 2.95-in (75 mm) length of 1-in hose
3. 1 x 1 x 5/8-in T-fitting
4. 2.4-in (61 mm) length of 1-in hose
5. 49.21-in (1250 mm) length of 1-in hose
6. 5/8-in clamp
7. 90-degree 5/8-in hose
8. 5/8-in double barb adapter
9. 49.72-in (1263 mm) length of 5/8-in hose

10. With cooling system completely drained, disconnect the return coolant hose at the cowl.
11. Install 49.21-in (1250 mm) length of 1-in hose (Figure 2, Item 5) on the coolant return port on the cowl.
12. Remove and discard the coolant supply hose between the shutoff valve and the driver heat exchanger.
13. Install 2.4-in (61 mm) length of 1-in hose (Figure 2, Item 4) at the shutoff valve outlet. Secure with 1-in clamp (Figure 2, Item 1).
14. Install 1 x 1 x 5/8-in T-fitting (Figure 2, Item 3) behind the 2.4-in (61 mm) length of 1-in heater hose. Position the T-fitting at the 6 o'clock position. Secure with 1-in clamp (Figure 2, Item 1).
15. Install 2.95-in (75 mm) length of 1-in hose (Figure 2, Item 2) between the T-fitting and driver heater inlet. Secure with 1-in clamp (Figure 2, Item 1).
16. Install 90-degree 5/8-in hose (Figure 2, Item 7) at the 5/8-in connection on the T-fitting. Secure with 5/8-in clamp (Figure 2, Item 6).
17. Install the 5/8-in double barb adapter (Figure 2, Item 8) to the 90-degree 5/8-in hose (Figure 1, Item 7). Secure with a 5/8-in clamp (Figure 2, Item 6).
18. Install 65.0-in (1651 mm) of 5/8-in heater hose (Figure 2, Item 9) to the double barb adapter (Figure 2, Item 8). Secure with a 5/8-in clamp (Figure 2, Item 6).
19. Route the heater hose toward the outlet at the rear of the driver heat exchanger.
20. Proceed to Step 30. See *Replacing and Routing Supply and Return Hoses (Rear of Heat Exchanger)*.

## Replacing and Routing Supply Hoses at Front of Heat Exchanger (WITHOUT Shutoff Valve):

Perform the following steps for buses without a shutoff valve near the front of the heat exchanger.

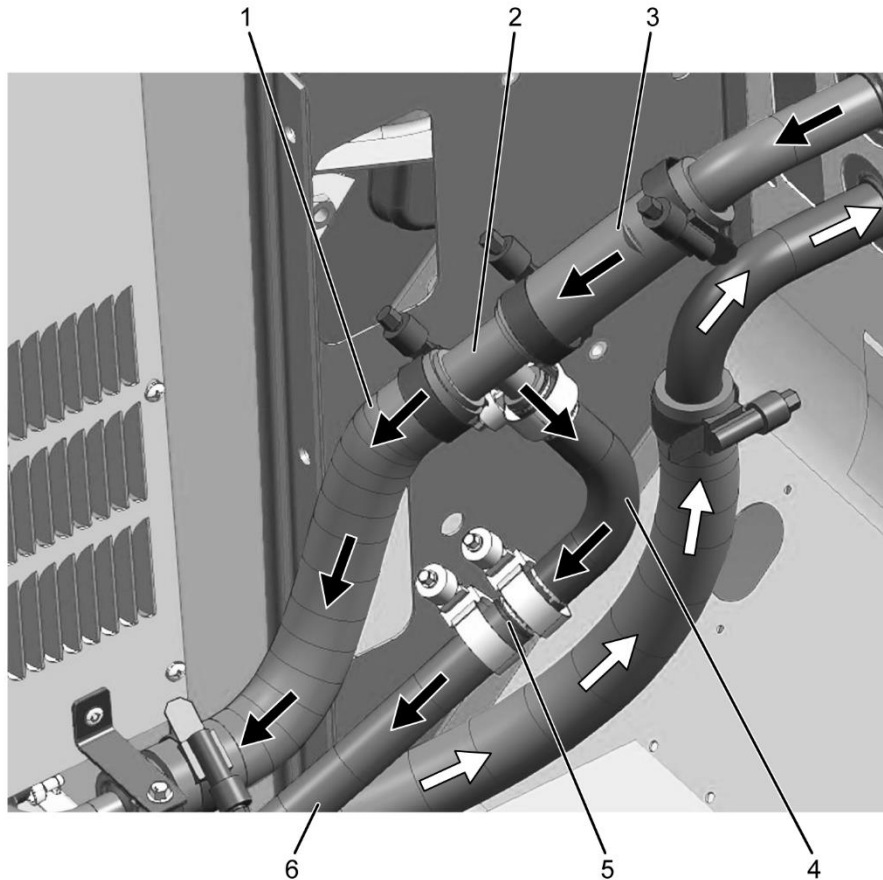

0000485666

**Figure 3. Hose Routing (Front of Heat Exchanger Without Shutoff Valve)**

1. 9.84-in (250 mm) length of 1-in hose
2. 1 x 1 x 5/8-in T-fitting
3. 5.15-in (131 mm) length of 1-in hose
4. 90-degree 5/8-in hose
5. 5/8-in double barb adapter
6. 65.0-in (1651 mm) length of 5/8-in hose

21. Disconnect existing coolant supply hose between the firewall and driver heat exchanger.
22. Install 5.15-in (131 mm) length of 1-in hose (Figure 3, Item 3) at the firewall. Secure hose with a 1-in clamp.
23. Install 1 x 1 x 5/8-in T-fitting (Figure 3, Item 2) to the 5.15-in (131 mm) length of hose. Rotate T-fitting to 6 o'clock position (with 5/8-in port pointing downward). Secure with 1-in clamp.
24. Install 9.84-in (250 mm) length of 1-in hose (Figure 3, Item 1) between the T-fitting (Figure 3, Item 2) and the driver heater inlet. Secure hose with 1-in clamps.
25. Install the 90-degree 5/8-in hose (Figure 3, Item 4) to the 5/8-in port on the T-fitting (Figure 3, Item 2). Secure with a 5/8-in clamp.
26. Install the 5/8-in double barb adapter (Figure 3, Item 5) to the 90-degree hose. Secure with a 5/8-in clamp.
27. Install 65.0-in (1651 mm) of 5/8-in heater hose (Figure 3, Item 6) to the 5/8-in double barb adapter (Figure 3, Item 5). Secure with a 5/8-in clamp.
28. Route the heater hose toward the outlet at the rear of the driver heat exchanger.
29. Proceed to Step 30. See *Replacing and Routing Supply and Return Hoses (Rear of Heat Exchanger)*.

## Replacing and Routing Supply and Return Hoses (Rear of Heat Exchanger):

Perform the following steps for all hose configurations.

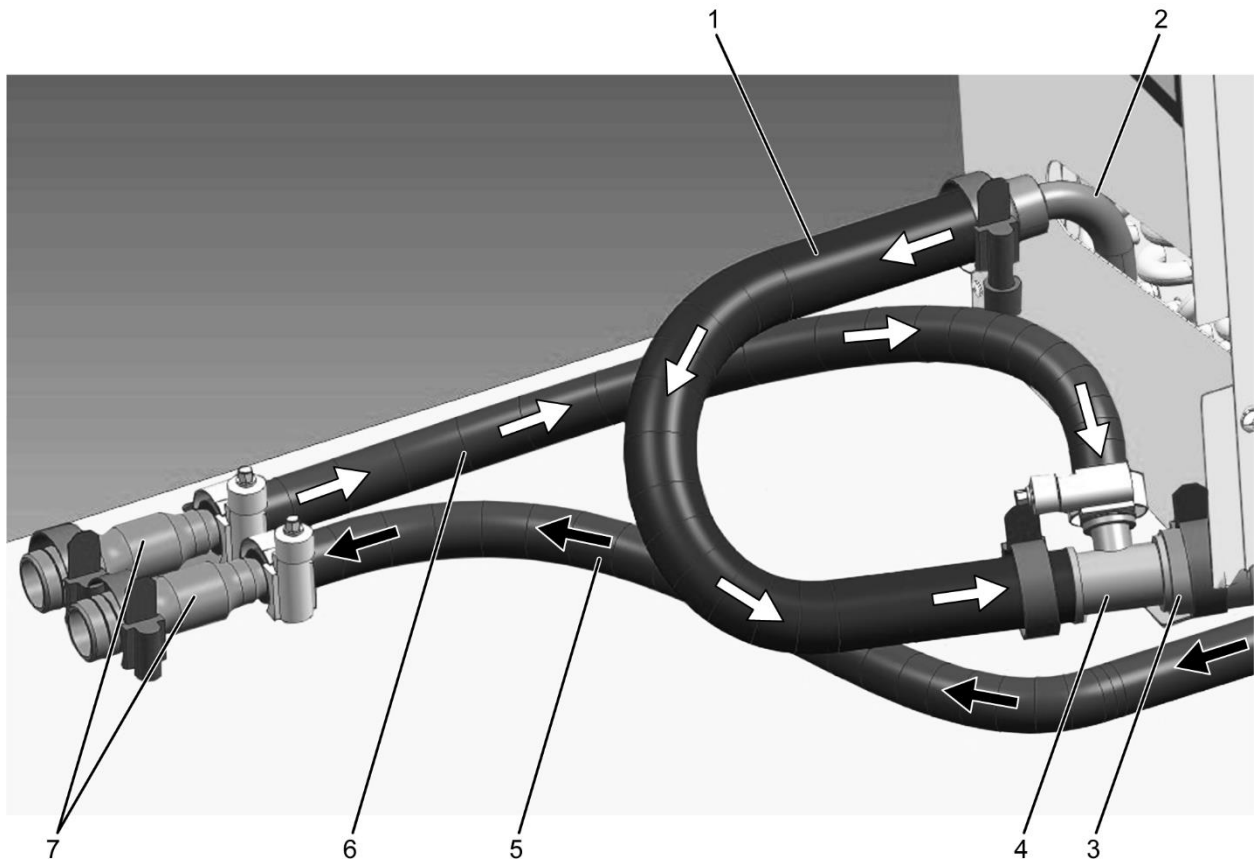

0000485667

**Figure 4. Hose Routing Behind Heat Exchanger**

1. Bus body hose
2. Driver heat exchanger outlet
3. 1-in coolant return hose
4. 1 x 1 x 5/8-in T-fitting
5. 49.7-in (1263 mm) length of 5/8-in hose
6. 18.3-in (465 mm) length of 5/8-in hose
7. 1 x 5/8-in adapter

30. Disconnect the existing 1-in hose from the driver heat exchanger outlet (Figure 4, Item 2).
31. Install bus body hose (Figure 4, Item 1) on the driver heat exchanger outlet (Figure 4, Item 2). Secure hose with 1-in clamp.
32. Install 1 x 1 x 5/8-in T-fitting (Figure 4, Item 4) between the bus body hose (Figure 3, Item 1) and the 1-in coolant return hose (Figure 4, Item 3). Secure with 1-in clamps.
33. Install 18.3-in (465 mm) length of 5/8-in hose (Figure 4, Item 6) to the 5/8-in port on the T-fitting (Figure 4, Item 4). Secure with 1-in clamp.
34. Install 1 x 5/8-in adapter (Figure 4, Item 7) to 5/8-in coolant return hose (Figure 4, Item 6). Secure with 5/8-in clamp.
35. Cut the 1-in return hose connected to the underseat heat exchangers leaving enough length to connect to the 1 x 5/8-in adapter installed in the previous step. Secure with 1-in clamp. Discard length of 1-in hose that was cut off.
36. Install 1 x 5/8-in adapter (Figure 4, Item 7) to 5/8-in coolant supply hose (Figure 4, Item 5). Secure with 5/8-in clamp.
37. Cut the 1-in supply hose connected to the underseat heat exchangers, leaving enough length to connect to the 1 x 5/8-in adapter installed in previous step. Secure with 1-in clamp. Discard length of 1-in hose that was cut off.
38. Proceed to Step 39 (see *Completion*).



0000485668

**Figure 5. Hose Routing Example (Front of Heat Exchanger)**

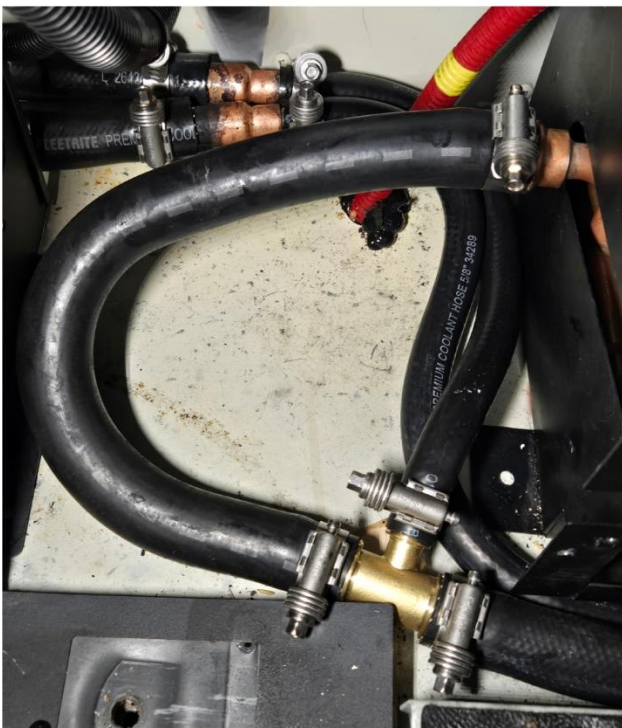

0000485669

**Figure 6. Hose Routing Example (Rear of Heat Exchanger)**

**Completion:**

- 39. Perform coolant system fill procedure. Refer to appropriate service manual for detailed procedures.
- 40. Perform cooling system pressure test on cabin heater circuit and inspect for leaks. Refer to appropriate service manual for detailed procedures.
- 41. Reinstall driver heat exchanger trim and closeout panels.
- 42. Reconnect High-Voltage Isolation Level 1. Refer to appropriate service manual for detailed procedure.
- 43. Turn 12V disconnect switch ON.
- 44. Close and latch hood.
- 45. Remove wheel chocks.

**LABOR INFORMATION**

Operation number must appear on all claims.

<b>Operation Number</b>	<b>Description</b>	<b>Time</b>
A40-24111-1	Coolant valve reroute	3.0 hrs

**Table 3** Labor Information

**WARRANTY CLAIMS**

Warranty claim expense is to be charged to Warranty. Claims are to be submitted in the normal manner, making reference to Field Service Campaign 24111.

Section 7 of the Warranty Policy and Procedures Manual contains further information related to the submission and processing of AFC / Recall claims.

As with all claim submissions, items acquired locally must be submitted in the “Other Charges” tab. The cost of any bulk items (such as a bag of cable tie straps, roll of wire, barrel of oil, or tube of silicone) should be prorated for the cost of the individual pieces / amount used during each repair.

To make sure this important improvement is made in a timely manner, all claims for 24111 activity must be submitted by 30 September 2025 or within the normal warranty period for the component repaired, if after 30 September 2025.

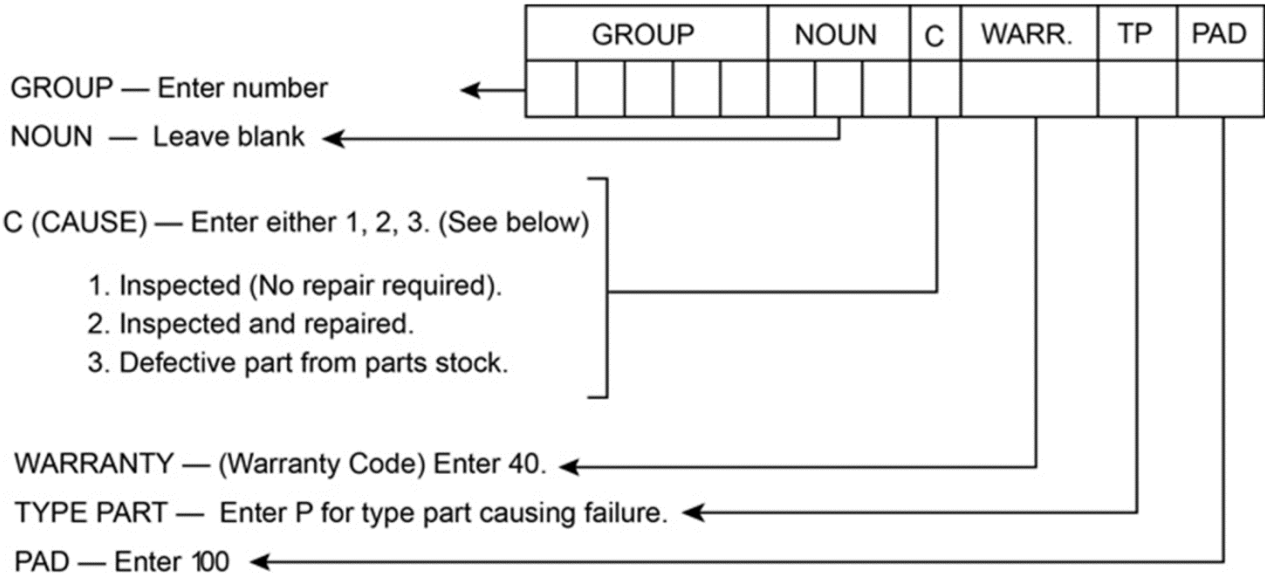

000047910