

# 2025 Tacoma and Tacoma HV Pre-Delivery Service (PDS)

**Service Category** General

**Section** Pre-Delivery Service

**Market** USA

Toyota Supports  
 ASE Certification 

## Applicability

YEAR(S)	MODEL(S)	ADDITIONAL INFORMATION
2025	Tacoma, Tacoma HV	

## Introduction

Pre-Delivery Service (PDS) is a critical step in satisfying our new car customers. Customer feedback indicates the following areas deserve special attention when performing PDS:

- Careful inspection for paint chips/scratches and body dents/dings.
- Proper operation of electrical accessories (including interior light, clock, and radio reset).
- Interior cleanliness.
- Proper function of mechanical systems.

Customer retention and proper maintenance of vehicles are, and have always been, a major focus for Toyota. To help remind customers that regular service is essential to the proper maintenance of the vehicle, dealers are required to install a service reminder sticker before delivery. By doing this, customers will be reminded to return to your dealership for service. Your current service reminder sticker may be used. (See PDS Check Sheet item 8 of "Final Inspection and Cleaning.")

This bulletin contains the PDS procedures that apply specifically to 2025 model year Tacoma and Tacoma Hybrid vehicles.

Refer to [T-SB-0028-24](#), the universal *Check Sheet* that contains PDS steps that apply to all 2025 model year Toyota vehicles. To properly perform a complete PDS, you must complete all procedures contained in this TSB as well as the universal PDS Check Sheet.

In addition, if the vehicle is stored for over 30 days, refer to [T-SB-0023-24](#), *Long-Term Vehicle Storage Guidelines*.

## 2025 Tacoma and Tacoma HV Pre-Delivery Service (PDS)

---

### Introduction (continued)

Refer to the table below for a definition of terms that may be used in this bulletin.

**Table 1.**

TERM	ACRONYM	DEFINITION
Conventional Vehicle	CV	A vehicle with only a gasoline engine for propulsion
Electrified Vehicle	EV	A vehicle that utilizes a hybrid, plug-in hybrid, fuel cell, or battery electric system for propulsion
Hybrid Electric Vehicle	HEV	A vehicle with both a gasoline engine and a HV Battery
Plug-in Hybrid Electric Vehicle	PHEV	A vehicle with both a gasoline engine and a HV Battery that can be charged externally
Battery Electric Vehicle	BEV	A vehicle with only a HV Battery that can be charged externally
Fuel Cell Electric Vehicle	FCEV	A vehicle with both a hydrogen fuel cell and a HV Battery
State of Charge	SOC	The remaining capacity available in a battery
12-Volt	12V	Standard 12V battery used to power electrical systems separate from high voltage components
High Voltage	HV	HV Battery used to power the electrified vehicle

## 2025 Tacoma and Tacoma HV Pre-Delivery Service (PDS)

---

### Table of Contents

- [Warranty Policy](#) ..... 4
- [Warranty Information](#) ..... 4
- [Required Tools & Equipment](#) ..... 4
- [D/C Cut Fuse Installation](#) ..... 5
- [Front License Plate and Mounting Bracket Installation\\*](#) ..... 6
- [Check Torque of Wheel Fasteners](#) ..... 7
- [Power Running Boards Initialization\\*](#) ..... 8
- [Initialization of Power Tail Gate\\*](#) ..... 8
- [Tire Pressure Warning System \(TPWS\) Initialization](#) ..... 8
- [Head Unit System Reset](#) ..... 9
- [Customize ACC Function](#) ..... 9
- [Dealer Contact Information for Call Dealer Head Unit Function\\*](#) ..... 9
- [Navigation — Set Date & Time by GPS](#) ..... 9

\*If applicable.

## 2025 Tacoma and Tacoma HV Pre-Delivery Service (PDS)

### Warranty Policy

If the need for additional repairs or adjustment is noted during PDS, the required service should be performed under warranty. Reimbursement will be managed under the warranty policy.

**The Warranty Policy and Procedures Manual requires that you maintain the completed Check Sheet in the customer's file.** If you cannot produce a completed form for each retailed vehicle upon TMS and/or Region/Distributor audit, the PDS payment amount will be subject to debit.

An additional Repair Order completed in conjunction with normal PDS MUST have time punch/flags for service. If multiple repairs are performed, separate time flags MUST be punched for each repair.

### Warranty Information

OP CODE	DESCRIPTION	MODEL	TIME	OPF	T1	T2
001013	Pre-Delivery Service (PDS)	Tacoma	0.9	-	-	-
		Tacoma HV	1.4	-	-	-

### Required Tools & Equipment

REQUIRED EQUIPMENT	SUPPLIER	PART NUMBER	QTY
Techstream ADVi*	ADE	TSADVUNIT	1
Techstream 2.0		TS2UNIT	
Techstream Lite		TSLITEPDLR01	
Techstream Lite (Green Cable)		TSLP2DLR01	

\*Essential SST.

**NOTE**

- Only ONE of the Techstream units listed above is required.
- GTS+ software version 2024.03.004.02 or later is required.
- Additional Techstream units may be ordered by calling Approved Dealer Equipment (ADE) at 1-800-368-6787 or by visiting *TIS – Diagnostics – Tools & Equipment – Techstream Order Portal*.

## 2025 Tacoma and Tacoma HV Pre-Delivery Service (PDS)

### D/C Cut Fuse Installation

To minimize battery discharge during transportation and storage, the D/C cut fuse (30A) has been removed at the assembly plant and temporarily stored in the blank space of the relay block in the engine compartment. During PDS, reinstall the D/C cut fuse (30A) to its original location and confirm ALL related Diagnostic Trouble Codes (DTCs) are cleared.

Remove the D/C cut fuse (30A) from the blank space of the relay block in the engine compartment and install the D/C cut fuse (30A) in the relay block as shown.

**Figure 1.**

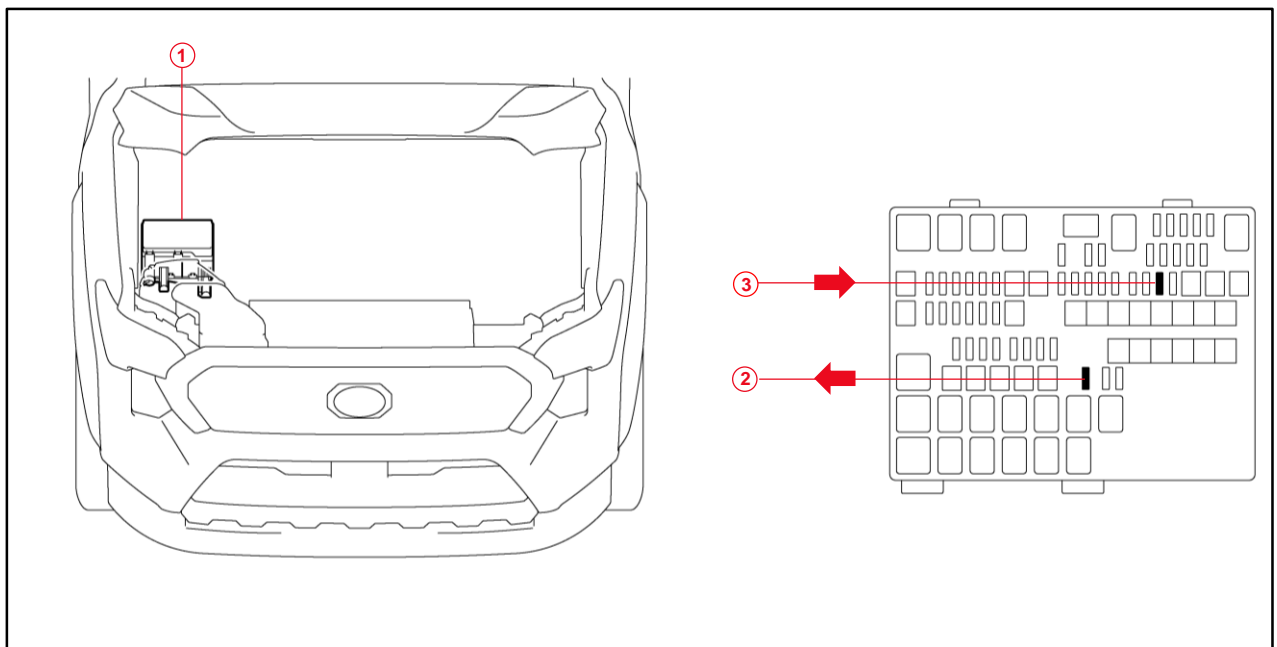

<b>1</b>	<b>Relay Block</b>
<b>2</b>	<b>Remove the D/C Cut Fuse (30A)</b>

<b>3</b>	<b>Install the D/C Cut Fuse (30A) (Original Location)</b>
----------	---

**NOTE**

- With the D/C cut fuse (30A) removed, if ANY DTCs are detected when the ignition is turned ON during transportation, use Global Techstream Software (GTS+) to clear ALL DTCs AFTER ensuring that there are NO malfunctions.
- While the vehicle is stored at the dealership, disconnect the negative (-) battery terminal to prevent battery discharge. Refer to [T-SB-0021-24](#), *Battery Inspection and Maintenance During PDS* for battery maintenance information.

## 2025 Tacoma and Tacoma HV Pre-Delivery Service (PDS)

### Front License Plate and Mounting Bracket Installation

The front license plate bracket and two self-tapping screws are loaded in the vehicle at the assembly plant. Follow this procedure to install the front license plate bracket and front license plate in states where it is required by law.

**NOTICE**

- Do NOT drill holes through the bumper cover.
- Do NOT over-tighten the self-tapping screws.

1. Disengage the clips to remove the two hole covers from the front bumper.

2. Install the two grommets to the front bumper.

**Figure 2.**

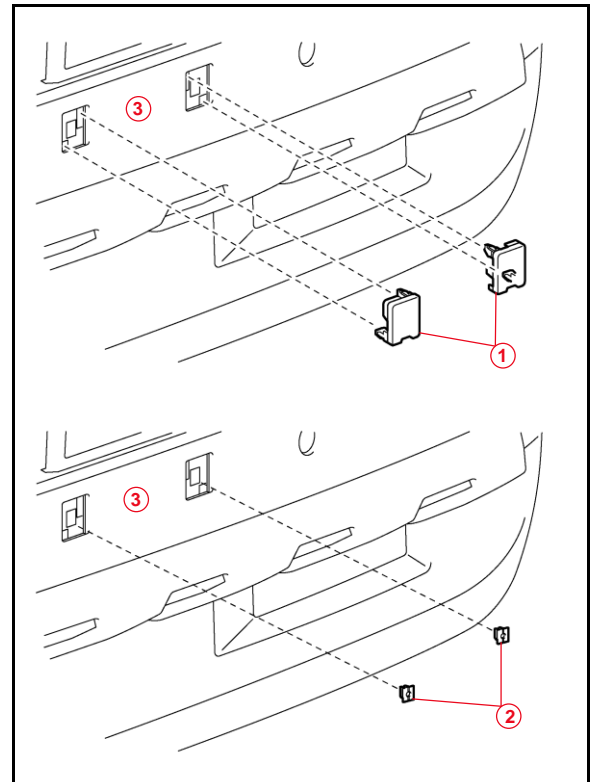

<b>1</b>	<b>Hole Covers</b>
<b>2</b>	<b>Grommets</b>
<b>3</b>	<b>Front Bumper</b>

## 2025 Tacoma and Tacoma HV Pre-Delivery Service (PDS)

### Front License Plate and Mounting Bracket Installation (continued)

3. Insert the front license plate onto the tabs on the bracket.
  
4. Align the holes on the license plate with the holes on the license plate bracket.
  
5. Install the license plate with the two self-tapping screws to the front bumper in the order as shown in Figure 3.

**Figure 3.**

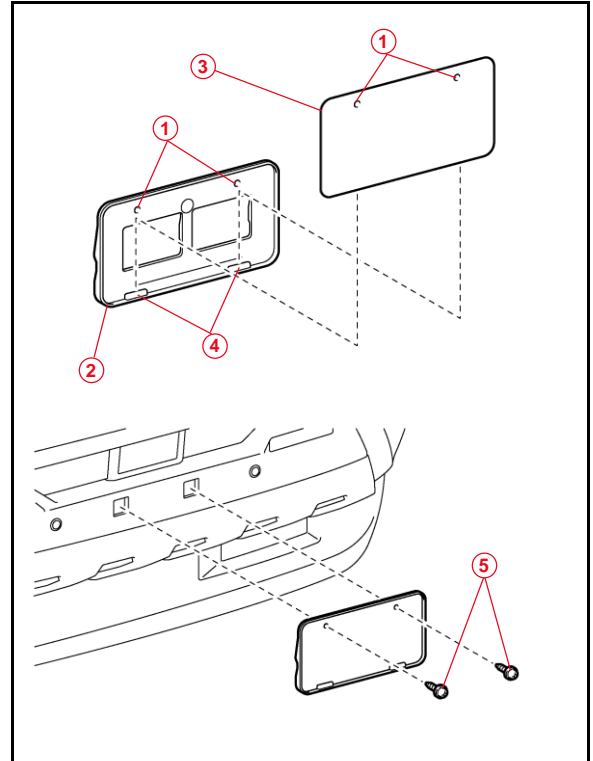

<b>1</b>	<b>Holes</b>
<b>2</b>	<b>License Plate Bracket</b>
<b>3</b>	<b>Front License Plate</b>
<b>4</b>	<b>Tabs</b>
<b>5</b>	<b>Self-tapping Screws</b>

### Check Torque of Wheel Fasteners

Using a calibrated torque wrench, verify the wheel fasteners on each wheel are tightened to at least the specified torque listed in the Repair Manual:

- [2025](#) Tacoma and Tacoma HV:  
*General – Maintenance – Tire and Wheel – Installation*

**NOTICE**

**Do NOT continue to tighten once verified.**

## 2025 Tacoma and Tacoma HV Pre-Delivery Service (PDS)

---

### Power Running Boards Initialization (Limited Only)

When removing the D/C cut fuse, it is necessary to initialize the power running board system. Refer to the applicable Repair Manual for the Power Running Board System initialization procedure:

- [2025](#) Tacoma and Tacoma HV:  
*Vehicle Exterior – Exterior Panels / Trim – Power Running Board System – Initialization*

**NOTE**

Jam protection will NOT be active during this procedure.

### Initialization of Power Tail Gate (TRD Off Road or Limited)

As a result of the removal of the D/C cut fuse with the tail gate opened, the automatic function of the power tail gate will be inoperative due to loss of the stored tail gate position memory. Refer to the applicable Repair Manual for the Power Tail Gate System initialization procedure:

- [2025](#) Tacoma and Tacoma HV:  
*Vehicle Exterior – Door / Hatch – Power Tail Gate System – Initialization*

**HINT**

If the D/C cut fuse is removed with the tail gate closed, initialization will not be required.

### Tire Pressure Warning System (TPWS) Initialization

Refer to the applicable Repair Manual for the TPWS initialization procedure:

- [2025](#) Tacoma and Tacoma HV:  
*Suspension – Tire Pressure Monitoring –  
Tire Pressure Warning Receiver (For Single Cab) – Initialization*
- [2025](#) Tacoma and Tacoma HV:  
*Suspension – Tire Pressure Monitoring –  
Tire Pressure Warning Receiver (For Double Cab) – Initialization*

**NOTE**

- To adjust the tire pressure correctly when the outside temperature is significantly colder than shop temperature, perform a Health Check using GTS+ and select the compensation tire pressure checkbox. Compensation pressures will display on the Health Check results screen. Adjust the tire pressure when the tires are cold.
- The spare tire does NOT have a TPWS sensor.

## 2025 Tacoma and Tacoma HV Pre-Delivery Service (PDS)

---

### Head Unit System Reset

Prior to vehicle delivery, please confirm that the welcome screen with language options appears on the head unit display when ignition is switched to the ON position. There may be instances where the welcome screen with language options may not properly appear on the head unit display.

If the welcome screen showing language options is not displayed, complete the following steps:

1. Select the Settings option (gear icon).
2. Scroll down and select the Info & Security option.
3. The System Reset dialogue box will appear. Select Reset to confirm the resetting of the system.
4. Confirm that the welcome screen with language options is now displayed.

### Customize ACC Function

The pre-startup function detects when a user enters the vehicle and energizes the audio head unit (+BA) so that the multimedia system can quickly be used. This function is not enabled at the factory to reduce parasitic current draw in transit and storage. To enable this function, it is necessary to set the ACC customization function in the navigation display to OFF.

1. Turn the engine switch (power switch) to the ON position (ON mode).
2. Enter the following menus: *Settings – Vehicle Customization – Utility – ACC Customize*.
3. Change the setting to OFF.

### Dealer Contact Information for Call Dealer Head Unit Function

Refer to the *Multimedia System Owner's Manual* to add dealer contact information.

- [2025](#) Tacoma and Tacoma HV:  
*Section 2-8 Vehicle settings – Setting dealer information*

### Navigation — Set Date & Time by GPS

Prior to vehicle delivery, it is necessary to turn the Set Date & Time by GPS setting to the ON position.

1. Turn the engine switch (power switch) to the ON position (ON mode).
2. Navigate the following menus in the head unit: *Settings – General – Date & Time – Set date & time by GPS*.
3. Ensure the Set Date & Time by GPS function is set to the ON position.