



## Seat Belt Buckle Update (U.S)

*This instruction refers to other documents that are necessary to do the procedure.*

This instruction is applicable to the RH and LH side. The illustrations show the LH side.

This instruction is applicable to Agera RS US version.

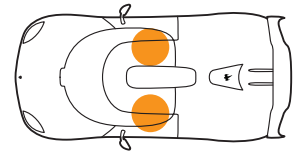

If you have issues while you follow the instruction, do not continue with this instruction. Submit a KATS ticket to contact Koenigsegg.

### Situation

The seat belt reminder may be activated when the seat belt is fastened.

### Action

Install the new belt buckle with the new harness.

PARTS	REFERENCE	QUANTITY
M8 flange lock nut	130-141-2008	8*
Seat belt buckle with harness	170-884-2001	2
Seat belt buckle rework harness	1031882	2
TOOLS	SPECIFICATION	QUANTITY
General mechanical tools	–	–
Removal tool for GT 150 and 280	100903	1
CONSUMABLES	REFERENCE	QUANTITY
Tesa fleece tape 15x9 (Cable tape)	3718-011	–
Zip ties	–	–
Zip tie anchor**	130-371-9033	10

\*Quantity for two seats. \*\*This is only necessary if the old zip tie anchor has become loose.

### Prepare

Remove the seat, refer to [WOM-00540](#).

### Replace the Belt Buckle

1. Remove the T40 screw **A** from the clip that holds the harness in position.

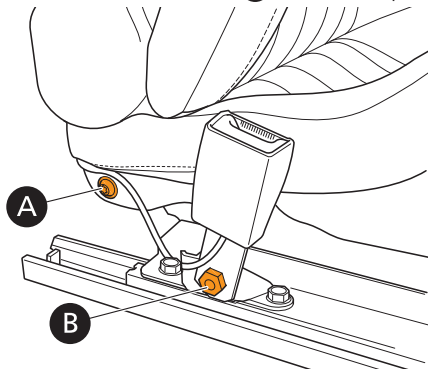

2. Remove the 16 mm nut **B** from the belt buckle.
3. Put the seat with the bottom up on a flat and smooth surface.
4. Record the routing of the belt buckle harness.





5. Record the position and number of zip ties along the belt buckle harness.
6. Cut the zip ties from the belt buckle harness.
7. Disconnect the X279 connector **C** from the belt buckle harness.

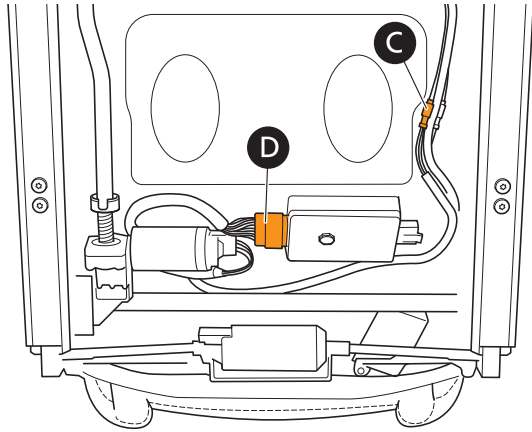

### Note

Follow the harness from the belt buckle to the connector and make sure that you disconnect the correct connector.

8. Remove the belt buckle together with the harness from the seat.
9. Send the belt buckle to Koenigsegg, refer to *Parts to be Returned*.
10. Record the position and number of zip ties on the seat bottom harness, from the X279 connector **C** to the X274 connector **D**.
11. Remove the zip ties:
  - If a zip tie anchor is loose, replace it with a new one.
  - If the old zip tie anchor has a cutout to make it install in the correct position, it is also necessary to make a cutout in the new one.
12. Cut off the X279 connector **C** from the wires that are attached to the seat bottom harness.

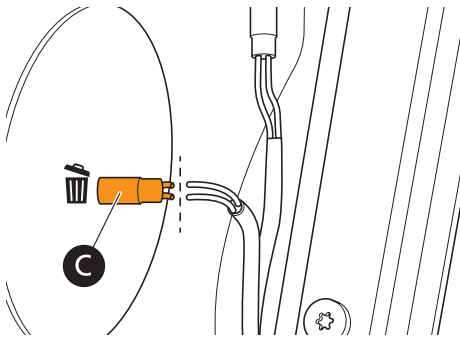

13. Discard the X279 connector **C**.
14. Disconnect the X274 connector **D** from the seat node.
15. Remove the cover from the X274 connector:

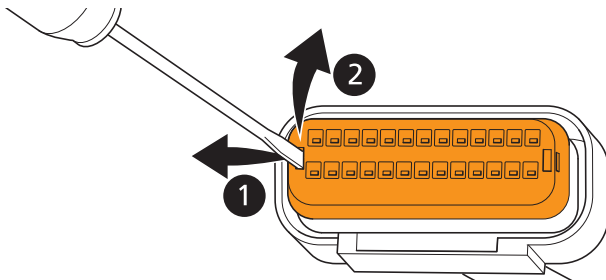



- 15.1 Use a small flat head screwdriver on one side of the cover and pull out ❶ from the connector and at the same time pull the cover up ❷.
- 15.2 Do step 15.1 for the other side of the cover.

### Note

If the cover for the connector is missing, a new one must be installed.

- 16. Unwind approximately 10 cm of tape from the connector.

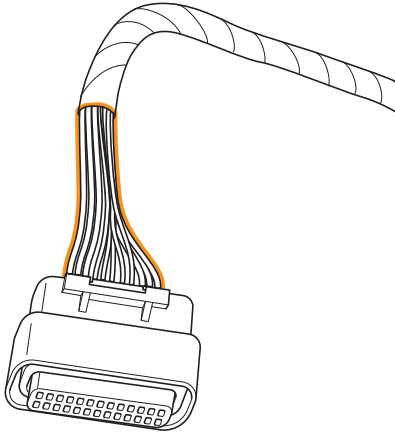

- 17. Disconnect the white wire from pin 24 on the X274 connector ❸.

Tool: 100903

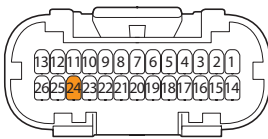

View from the wire side

- 17.1 Insert the removal tool parallel and as close to the terminal ❹ as possible.

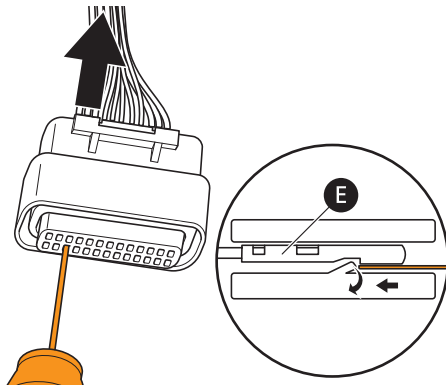

- 17.2 Push in and at the same time push away from the terminal ❸ and pull the wire out.

- 18. Disconnect the brown wire from pin 11 on the X274 connector:

Tool: 100903

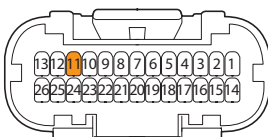

View from the wire side

- Do steps 17.1 thru 17.2 for the brown wire.

- 19. Cut off the terminals from the two wires that you disconnected.





20. Discard the terminals.
21. Fold back the brown and white wire over the harness.

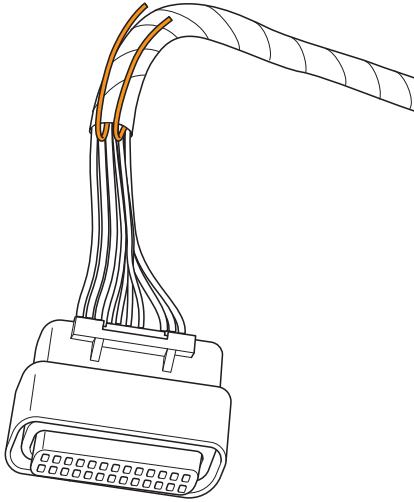

22. Put the new harness in position.  
**Part:** 1031882
23. Put the white wire terminal from the new harness into pin 24. Listen for a click to make sure the terminal is fully in.
  - Carefully pull the harness to make sure that it is correctly connected.

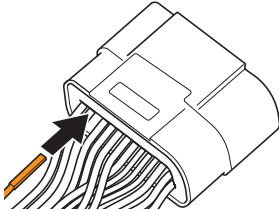

24. Put the brown wire terminal from the new harness into pin 11. Listen for a click to make sure the terminal is fully in.
  - Carefully pull the harness to make sure that it is correctly connected.

25. Install the cover for the X274 connector.
26. Use tape to attach the cables along the harness.

**Consumable:** Cable tape

27. Do the routing of the new harness along the seat bottom harness.
28. Make sure that the new X279 connector is at the same position as the old one was.
29. Put tape around the new harness together with the seat bottom harness, from the X274 connector to the X279 connector.

**Consumable:** Cable tape

30. Connect the X274 connector to the seat node.
31. Put the belt buckle with the harness in position.  
**Part:** 166-884-2001
32. Install the belt buckle with the 16 mm bolt **B**.

**Torque:** 70 Nm

33. Connect the X279 connector.
34. Attach the belt buckle harness with zip ties. Use the same positions as recorded in step 5.
35. Attach the seat bottom harness with zip ties. Use the same positions as recorded in step 10.
36. Attach the belt buckle harness in the clip under the bolt **A**.
37. Install the T40 screw **A** on the clip.

**Torque:** 6 Nm

38. Install the seat with the new nuts, refer to [WOM-00540](#).

**Part:** 130-141-2008





### Warranty Information

If the repair is covered by the warranty terms, refer to Koenigsegg Warranty Process.

**OPERATION**

KWO902613

**PART NO**

Refer to the invoiced kit number

### Parts to be Returned

PARTS	REFERENCE	QUANTITY
Seat belt buckle	166-884-2004	2

