



Service Engineering Operations
Customer Service Division

Ford Motor Company
PO Box 1904
Dearborn, Michigan 48121

December 2, 2024

TO: All U.S. Ford and Lincoln Dealers

SUBJECT: **Customer Satisfaction Program 24N04 – Supplement #1**
Certain 2021-2023 Model Year F-150 HEV and 2022-2023 Model Year Maverick
HEV Vehicles
Replacement of Exhaust Gas Heat Recovery System If Failed

New! REASON FOR THIS SUPPLEMENT

- *Program Terms now include F-150s.*
- *Service Action – all vehicles can now be repaired, F-150 HEVs and Maverick HEV's*
- *Owner Notification Mailing Schedule – Owner letters are expected to be mailed in 1st Quarter, 2025.*
- *Updated Administrative Information:*
 - *Owner Refund information now includes F-150 HEV.*
- *Updated Labor Allowances and Parts Ordering Information:*
 - *New labor operation code for F-150 HEV*
 - *Updated parts ordering information*

New! PROGRAM TERMS

This program provides a one-time replacement (if needed) to the Exhaust Gas Heat Recovery (EGHR) system for 15 years of service or 150,000 miles from the warranty start date of the vehicle, whichever occurs first

This is a one-time repair program.

If a vehicle has already exceeded either the time or mileage limits, then this repair will last through March 31, 2026.

Coverage is automatically transferred to subsequent owners.

VEHICLES COVERED BY THIS PROGRAM

Vehicle	Model Year	Assembly Plant	Build Dates
F-150 HEV	2021-2023	Dearborn Truck	January 10, 2020 through September 8, 2023
Maverick HEV	2022-2023	Hermosillo	February 3, 2021 through January 13, 2023

US population of affected vehicles: 166,526. Affected vehicles are identified in OASIS.

REASON FOR PROVIDING A NO-COST, ONE-TIME REPAIR

In some of the affected vehicles, the printed circuit board within the EGHR actuator housing may fail due to water ingress, causing the EGHR valve to become stuck in position, and illuminating the Malfunction Indicator Light (MIL). In addition, for F-150 only, the EGHR coolant inlet port may break and cause engine coolant to leak out of the vehicle's cooling system.

New! SERVICE ACTION

- *Dealers are now authorized to repair all vehicles, F-150 HEVs and Maverick HEV's.*
- If the MIL is illuminated for an EGHR-related Diagnostic Trouble Code (DTC), per the technical instructions for this program, then the dealer will service the EGHR with an EGHR service kit. For new vehicle storage guidelines, refer to EFC13033, Storage Guidelines for New Vehicles.

To assist vehicle owners to have this repair completed when parts are available, dealers should:

- Arrange to pick up the owner's vehicle and drive it to the dealership for repairs
 - Re-deliver the owner's vehicle after repairs have been completed.
- Pick-Up & Delivery should be made available for all customers. Refer to the Rental and Claiming sections for further details.

New! OWNER NOTIFICATION MAILING SCHEDULE

Pending Agency approval and service part availability, Owner Letters are expected to be mailed during the 1st Quarter, 2025. Dealers should complete the repair if required and if the vehicle is eligible, whether or not the customer has received a letter.

New! ATTACHMENTS

- *Administrative Information*
- *Labor Allowances and Parts Ordering Information*
- Technical Instructions
- Mobile Service Repair Assessment
- Mobile Repair/Vehicle Pick-Up & Delivery Record
- Owner Notification Letters

QUESTIONS & ASSISTANCE

For questions and assistance, contact the Special Service Support Center (SSSC) via the SSSC Web Contact Site. The SSSC Web Contact Site can be accessed through the Professional Technician System (PTS) website using the SSSC link listed at the bottom of the OASIS VIN report screen or listed under the SSSC tab.

Customer Service Division

Customer Satisfaction Program 24N04 – Supplement #1**MOBILE SERVICE REPAIR ASSESSMENT LEVEL**

Ⓢ - Not a Mobile Service Repair

OASIS ACTIVATION

OASIS will be activated on September 30, 2024.

FSA VIN LISTS ACTIVATION

FSA VIN Lists will not be activated for this service action.

SOLD VEHICLES

- Only owners with affected vehicles that exhibit the covered condition will be directed to dealers for repairs.
- Dealers are to prioritize repairs of customer vehicles over repairs of new and used vehicle inventory.

STOCK VEHICLES

- Do not perform this program unless the affected vehicle exhibits the covered condition.

BRANDED / SALVAGED TITLE VEHICLES

Branded / salvaged title vehicles and vehicles with canceled warranty coverage is eligible for this program unless emission coverage is explicitly canceled, as indicated by one of the following OASIS Warranty Cancellation Messages only:

- SCRAPPED UNIT – ALL WARRANTY CANCELLED – TOTAL INCLUDING EMISSIONS
- ALL WARRANTIES CANCELLED INCLUDING EMISSIONS

New! OWNER REFUNDS

- Ford Motor Company is offering a refund for owner-paid repairs covered by this program if the repair was performed before the date of the Owner Notification Letter. This refund offer expires **March 31, 2026**.
- Dealers are also pre-approved to refund owner-paid emergency repairs that were performed away from an authorized servicing dealer after the date of the Owner Notification Letter. Non-covered repairs, or those judged by Ford to be excessive, will not be reimbursed.
- Refunds will only be provided for the cost associated with replacement of the EGHR actuator or the complete EGHR assembly.

Customer Satisfaction Program 24N04 – Supplement #1**RENTAL VEHICLES**

The use of rental vehicles is not approved for this program.

FORD PICK-UP & DELIVERY

- Dealers participating in the Remote Experience Program –
 - Refer to EFC14125, 2024 Remote Experience Program, Pick-Up & Delivery (PDL) Offset section for additional details.
- Dealers NOT participating in the Remote Experience Program –
 - Dealers may claim one-half labor hour per repair for vehicle Pick-Up & Delivery services.
 - Dealers must retain a Vehicle Pick-Up & Delivery Record with the repair order documentation.

REPAIR PHOTO SUBMISSION

Ford has requested photo evidence prior to performing the repair for this FSA.

Contact the SSSC and submit a VIN-specific Part Order contact via the SSSC Web Contact Site, and upload the necessary documentation as an attachment for review:

- File showing applicable DTCs present
- Vehicle mileage on cluster
- Door tag showing VIN
- This can be done in two ways:
 - Directly in the SSSC contact request form while submitting your contact on your desktop.
 - Via PTS Mobile under the Images / Files Upload menu selection
 - You should select SSSC in the sub-menu and ensure your P&A code is correct. Upload the photo(s) by selecting the appropriate FSA with the option to use a prior contact ID. These photo(s) will be associated with your SSSC contact during submission.
 - If you have not submitted a SSSC contact yet, then you can still upload the photo(s) via PTS Mobile, and the photo(s) will be available when opening your SSSC contact for this VIN and program.
- Upon approval, the SSSC will provide an approval code that must be used for claiming.

ADDITIONAL REPAIR (LABOR TIME AND/OR PARTS)

Additional repairs identified as necessary to complete the FSA should be managed as follows:

- For related damage and access time requirements, refer to the Warranty and Policy Manual – Section 6 – Ford & Lincoln Program Policies / General Information & Special Circumstances for FSA's / Related Damage.
- For vehicles within new vehicle bumper-to-bumper warranty coverage, no SSSC approval is required, although related damage must be on a separate repair line with the Related Damage radio button checked.
 - Ford vehicles – 3 years or 36,000 miles
- For vehicles outside new vehicle bumper-to-bumper warranty coverage, submit an Approval Request to the SSSC Web Contact Site before completing the repair.

Customer Satisfaction Program 24N04 – Supplement #1**CLAIMS PREPARATION AND SUBMISSION**

- **Technician Competency Requirement:** The STST Competency 10 certification requirement in the U.S. market only will be enforced starting with repair orders opened on or after April 1, 2024. FSA repairs will reject if the repairing technician is not certified in STST Competency 10 FSA. See EFC14251 for more details.
- **Note:** All repairs for this program should be claimed using the claim entry direction below regardless if the vehicle is still under the New Vehicle Limited Warranty.
 - Service Part Warranty (SPW) and/or Ford/Lincoln Loyalty Plans (ESP) eligible vehicles – Claim repairs to FSA 24N04 if the vehicle is still within time and mileage limits.
- **Claim Entry:** Enter claims using Dealer Management System (DMS) or One Warranty Solution (OWS) online.
 - When entering claims:
 - Claim type 31: Field Service Action
 - Sub Code: 24N04
 - Customer Concern Code (CCC): E29 “Check Engine” light troubles
 - Condition Code (CC): 42 Does Not Operate Properly
 - Causal Part Number: 5K245, Quantity 0
 - For additional claims preparation and submission information, refer to the Recall and Customer Satisfaction Program (CSP) Repairs in the OWS User Guide.
- **Related Damage/Additional labor and/or parts:** Must be claimed as Related Damage on a separate repair line from the FSA with the same claim type and subcode as described in Claim Entry above.

IMPORTANT: Click the Related Damage Indicator radio button.
- **Refunds:** Submit refunds on a separate repair line.
 - Program Code: 24N04 - Misc. Expense: ADMIN
 - Misc. Expense: REFUND - Misc. Expense: 0.2 Hrs.
 - Multiple refunds should be submitted on one repair line and the invoice details for each repair should be detailed in the comments section of the claim.
- **FORD PICK-UP & DELIVERY:**
 - Dealers participating in the Remote Experience Program –
 - Refer to EFC14125, 2024 Remote Experience Program, Pick-Up & Delivery (PDL) Offset section for additional details.
 - Dealers NOT participating in the Remote Experience Program –
 - Dealers may claim one-half labor hour per repair for vehicle Pick-Up & Delivery services.
 - Dealers must retain a Vehicle Pick-Up & Delivery Record with the repair order documentation.

Customer Satisfaction Program 24N04 – **Supplement #1**

New! LABOR ALLOWANCES

Description	Labor Operation	Labor Time
<p>Maverick – Check DTCs, and if DTCs P2C22, P2C23, P237C, P237D, P237E and/or P237F are present in the powertrain control module (PCM), replace Exhaust Heat Exchanger Actuator with the service kit – Includes time for actuator alignment using FDRS and clearing codes.</p> <p>Note: If DTCs are not present, program does not apply.</p>	24N04B	0.5 Hours
<p>F-150 – Check DTCs, and if DTCs P2C22, P2C23, P237C, P237D, P237E and/or P237F are present in the powertrain control module (PCM), replace Exhaust Heat Exchanger Actuator with the service kit – <u>Includes time for coolant top off, actuator alignment using FDRS and clearing codes.</u></p> <p>Note: If DTCs are not present, program does not apply.</p>	24N04C	0.8 Hours
<p>Ford Vehicle Pick-Up & Delivery Allowance: This allowance is only for <u>non-eligible</u> 2024 Remote Experience Program Dealers. NOTE: This allowance is for dealer-performed vehicle Pick-Up & Delivery for dealership repairs only. Can only be claimed once, regardless of outstanding FSAs repaired.</p>	24N04PP	0.5 Hours
<p>Time allowed to submit evidence of applicable DTCs P2C22, P2C23, P237C, P237D, P237E and/or P237F in the powertrain control module (PCM)</p>	24N04ZZ	0.2 Hours

New! PARTS REQUIREMENTS / ORDERING INFORMATION

Restricted Part Ordering:

To place an order for an **EGHR service kit** submit a VIN-specific Part Order contact via the SSSC Web Contact Site.

Vehicle must be present in the dealership. The VIN-specific part order must provide the following:

1. File showing applicable DTCs P2C22, P2C23, P237C, P237D, P237E and/or P237F in the powertrain control module (PCM).
2. Attach a photo of vehicle mileage.
3. Attach a photo of door tag showing VIN.
4. If the vehicle is off road, then refer to EFC14236. VOR escalation is required in DOW.
5. Upon approval, the SSSC will provide an approval code that must be used for claiming.

Service Part Number	Claim Quantity	Package Order Quantity	Number in Package	Description
PL3Z-5K245-B	1	1	1	F-150 HEV EGHR Service Kit
NZ6Z-5K245-A	1	1	1	Maverick HEV EGHR Service Kit

Dealers will be notified via a DOES II communication if circumstances warrant a change in part supply strategy and when open ordering resumes.

Customer Satisfaction Program 24N04 – **Supplement #1**

PARTS REQUIREMENTS / ORDERING INFORMATION (continued)

Order the parts below through normal order processing channels:

Service Part Number	Claim Quantity	Package Order Quantity	Number in Package	Description
VC-13DL-G	0.25	1	1	F-150 HEV only – 1 Quart Coolant – top off only (0.25 of 1 gallon)

To guarantee the shortest delivery time, an emergency order for parts must be placed.

DEALER PRICE

For the latest prices, refer to DOES II.

PARTS RETENTION, RETURN, & SCRAPPING

Follow the provisions of the Warranty and Policy Manual, Section 1 - WARRANTY PARTS RETENTION AND RETURN POLICIES. If a replaced part receives a scrap disposition, the part must be scrapped by all applicable local, state, and federal environmental protection and hazardous material regulations.

EXCESS STOCK RETURN

The excess stock returned for credit must have been purchased from Ford Customer Service Division by Policy Procedure Bulletin 4000.

REPLACED FSA PARTS INSPECTION AND SIGN OFF

Effective March 1st, 2021 all parts replaced as part of an FSA repair with a repair order open date of March 1st, 2021, or later must be inspected and signed off on the repair order by a member of your dealer fixed operations management team or an employee the task has been delegated to. If the task is to be delegated to a non-management employee, the employee needs to be someone other than the technician who completed the repair and needs to understand the importance of completing this task consistently and accurately.

- All parts replaced as part of an FSA repair should be returned to the parts department following the Warranty Parts Retention and Return Policies.
- Inspect the replaced parts to verify the FSA repair was completed.
- If the FSA repair is found to be complete, the designated employee signs the repair order line or parts return stamp area (electronic or hand signed) for the FSA repair indicating the parts were inspected and validated to have been replaced.
- After the parts have been inspected, they should be handled based on the guidance in the parts status report in the Online Warranty System (Hold, Return, CORE, Scrap, etc.). Please visit FMCDEALER > PARTS & SERVICE > WARRANTY ADMINISTRATION & WARRANTY PARTS RETURN for the latest [Immediate Scrap List](#) information.
- This process is subject to review during warranty audits for FSA repairs with a repair order open date of March 1st, 2021, or later. Any eligible FSA claims requiring parts replacement found not to have been inspected and signed off during a warranty audit will be subject to chargeback and consideration for enrollment into the Dealer Incomplete Recall Repair Process.

Customer Satisfaction Program 24N04 – *Supplement #1*

REPLACED FSA PARTS INSPECTION AND SIGN OFF (continued)

Note: Other approvals (electronic or handwritten) for add-on repair lines, dealer-owned vehicle repairs, and repeat repairs do not qualify as FSA parts inspection approvals. The post-repair FSA parts inspection process (electronic or handwritten) is independent of other warranty approval requirements. The approval by the designated employee implies that the FSA parts were found to be replaced and must be able to be identified on the Repair Order. If multiple FSAs require approval on a single Repair Order, each applicable occurrence will require individual post-repair approval by the designated employee.

CERTAIN 2021-2023 MODEL YEAR F-150 HEV AND 2022-2023 MODEL YEAR MAVERICK HEV VEHICLES — REPLACEMENT OF EXHAUST GAS HEAT RECOVERY SYSTEM IF FAILED

SERVICE PROCEDURE

IMPORTANT! The Service Technician Specialty Training (STST) Competency 10 certification requirement, for U.S. market only, will be enforced starting with repair orders opened on or after April 1, 2024. Field Service Action (FSA) repairs will reject if the repairing technician is not certified in STST Competency 10 FSA. See Electronic Field Communication (EFC) 14251 for more details.

IMPORTANT: This procedure was modified from the original Workshop Manual (WSM) procedure. Follow technical instructions carefully.

Perform Self Test

1. Log into Ford Diagnostic and Repair System (FDRS).

NOTE: Vehicle information is automatically retrieved by the diagnostic software and a Network Test is run. Vehicle identification data appears on the screen when this is complete.

2. Click **Read VIN from Vehicle** or manually enter the Vehicle Identification Number (VIN).

3. From the list on the RH side of the screen, select **Self-Test** and click **RUN**.

4. Check for the following Diagnostic Trouble Codes (DTCs): P2C22, P2C23, P237C, P237D, P237E, and/or P237F

- Are one or more of the above DTCs present?

No - This Field Service Action (FSA) does not apply.

Yes - Capture evidence of the DTCs and continue to Step 5.

5. Contact the SSSC and upload the necessary photo(s) or copy of documentation(s) as an attachment for review.

- File showing applicable DTCs present
- Vehicle mileage on cluster
- Door tag showing VIN



6. There are two ways to submit the requested items to SSSC.

- a. Directly in the SSSC contact request form while submitting your contact on your desktop.
- b. Via PTS Mobile under the Images/Files Upload menu selection. Select SSSC in the sub-menu and ensure your P&A code is correct. Upload the item(s) by selecting the appropriate FSA with the option to use a prior contact ID. The item(s) will be associated with your SSSC contact during submission.

NOTE: If you have not submitted an SSSC contact yet, then you can still upload the item(s) via PTS mobile, and the item(s) will be available when opening your SSSC contact for this VIN and recall.

7. Upon approval, the SSSC will provide an approval code that must be used for claiming.

8. For Maverick vehicles, proceed to **MAVERICK VEHICLES ONLY**, below. For F-150 vehicles, proceed to **F-150 VEHICLES ONLY**.

MAVERICK VEHICLES ONLY

1. Install *new* exhaust heat exchanger actuator. Follow the procedures in WSM Manual Section 309-00B.
2. Proceed to **FDRS ALIGNMENT PROCEDURE** on Page 9.

F-150 VEHICLES ONLY

1. Clamp off the heat exchanger coolant spigots. See Figure 1.

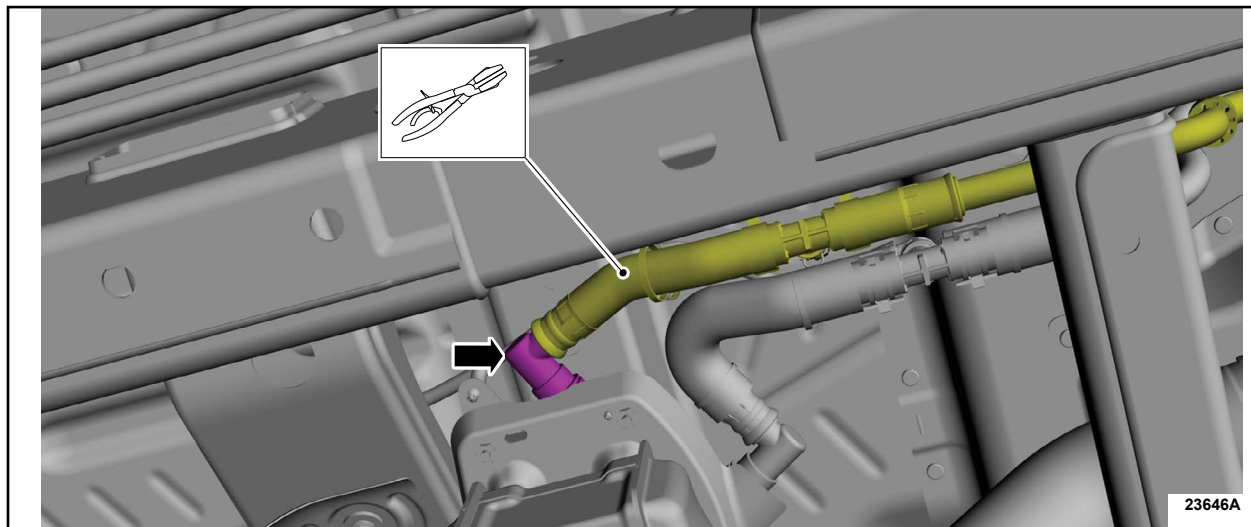

FIGURE 1



2. Disconnect the electrical connector and detach the wire retainer. See Figure 2.

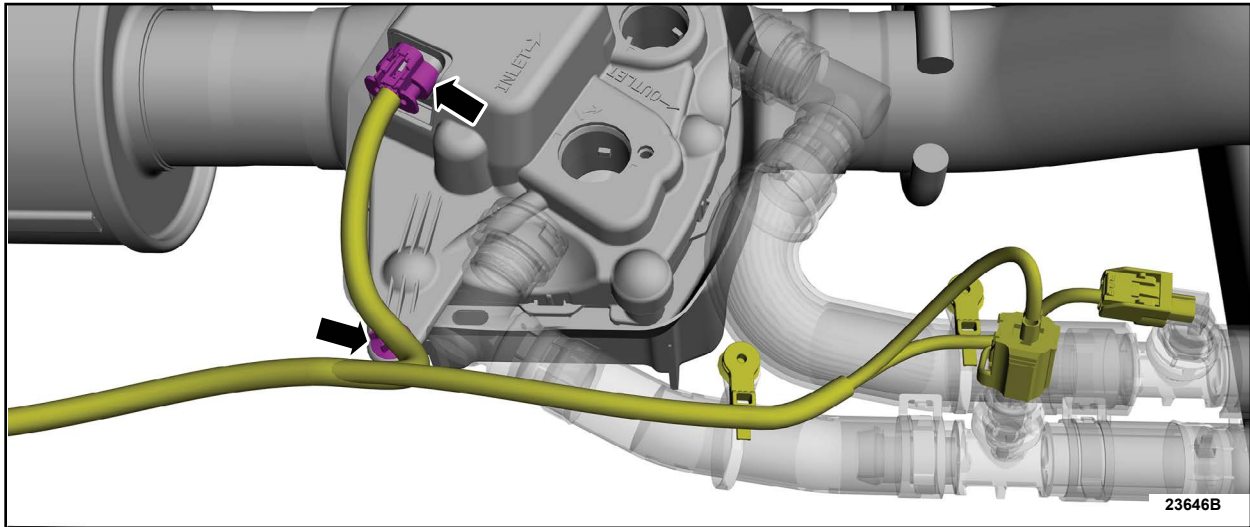

FIGURE 2

3. Release the tabs and remove the actuator cover. See Figure 3.

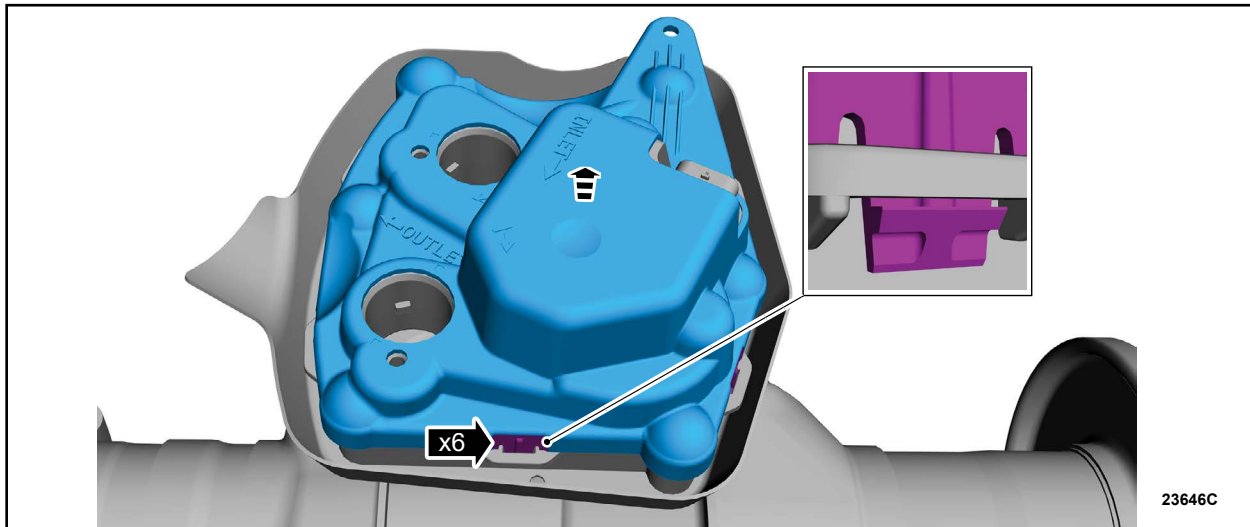

FIGURE 3



4. Remove the bolts and the exhaust heat exchanger actuator. See Figure 4.

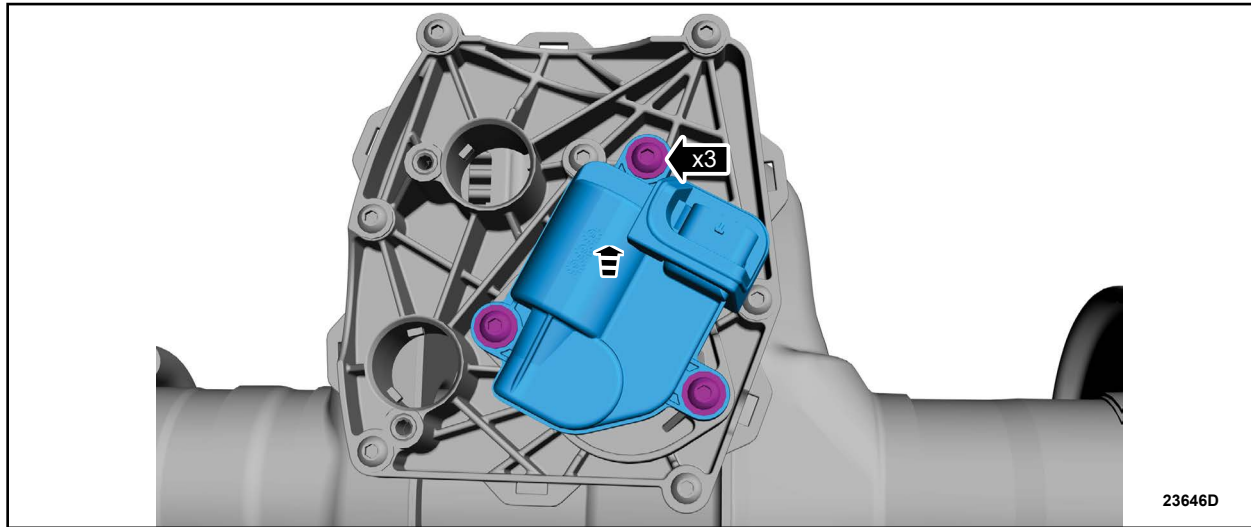

FIGURE 4

5. Inspect the heat exchanger and actuator for the O-ring seal. Remove the O-ring seal if it is on the heat exchanger. See Figure 5.

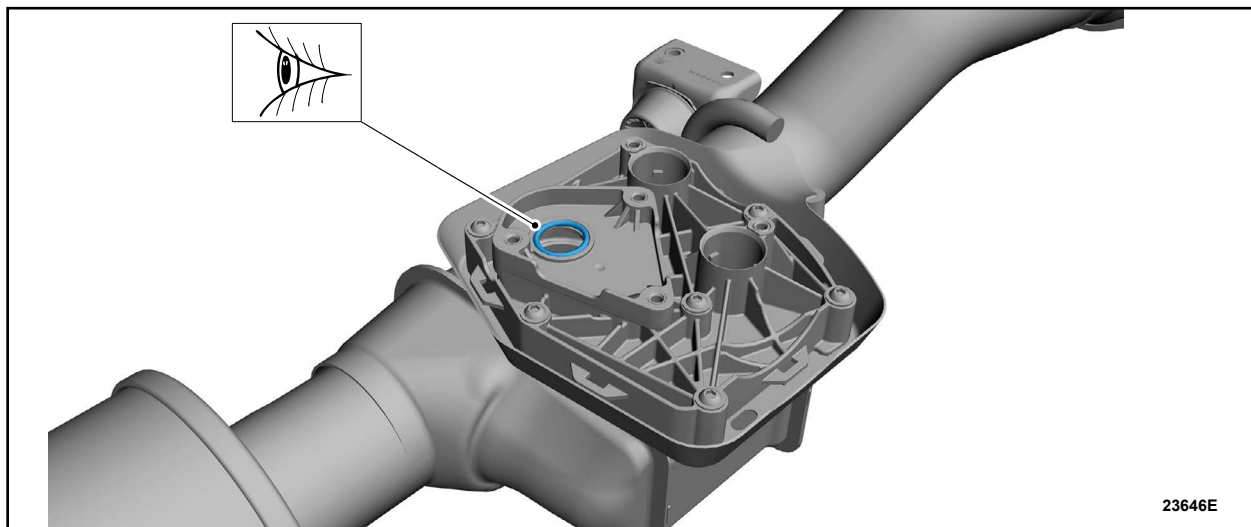

FIGURE 5



6. Position the dust seal on the actuator electrical connector area. See Figure 6.

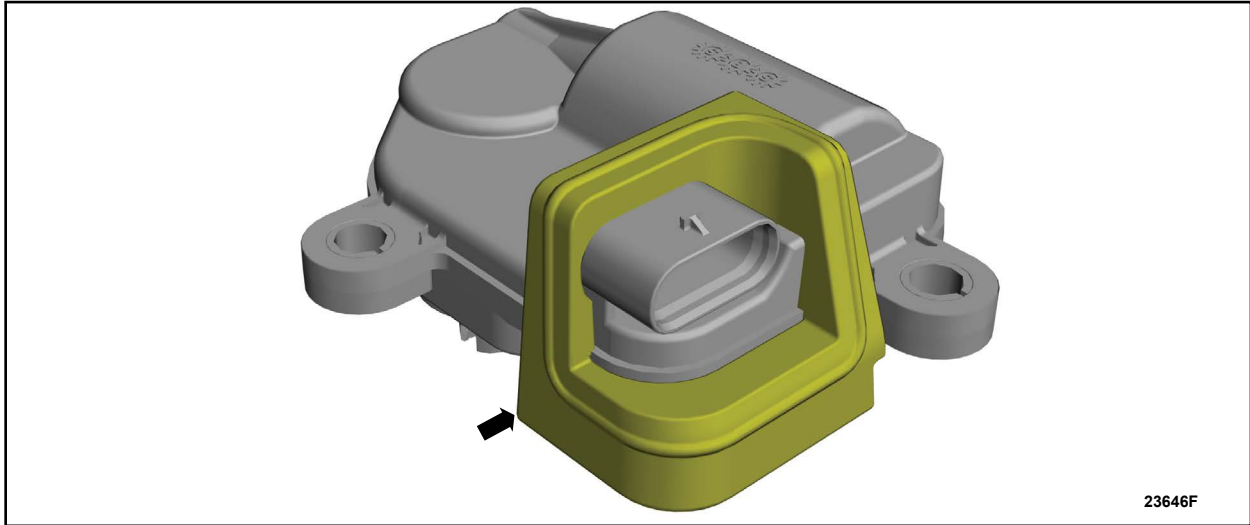

FIGURE 6

7. Install the O-ring seal on the actuator. See Figure 7.

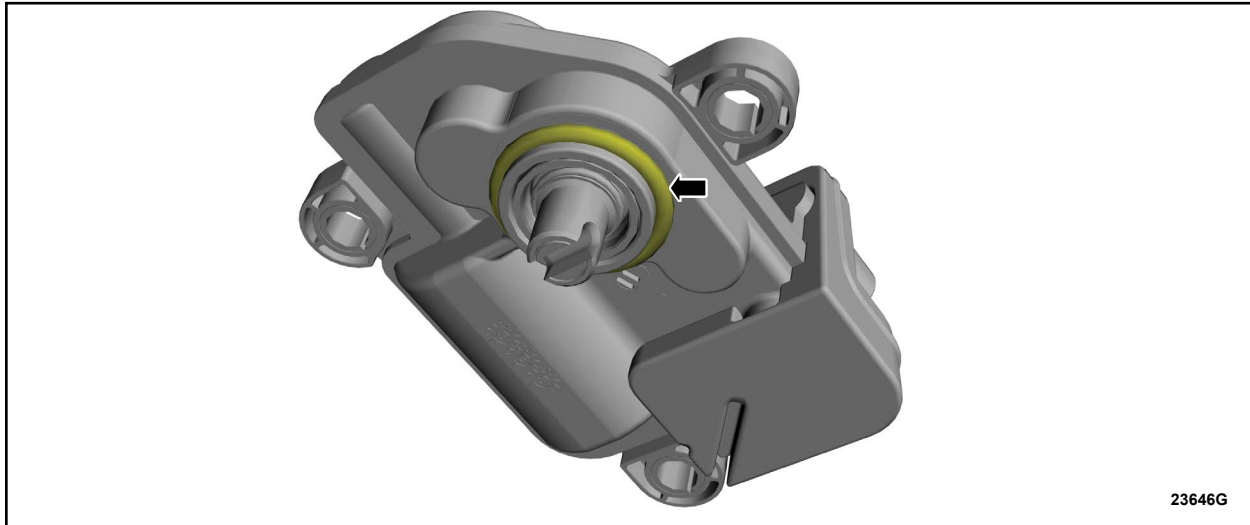

FIGURE 7



8. Align the slot on the actuator with the spring in the heat exchanger and install the actuator on the heat exchanger. See Figure 8.

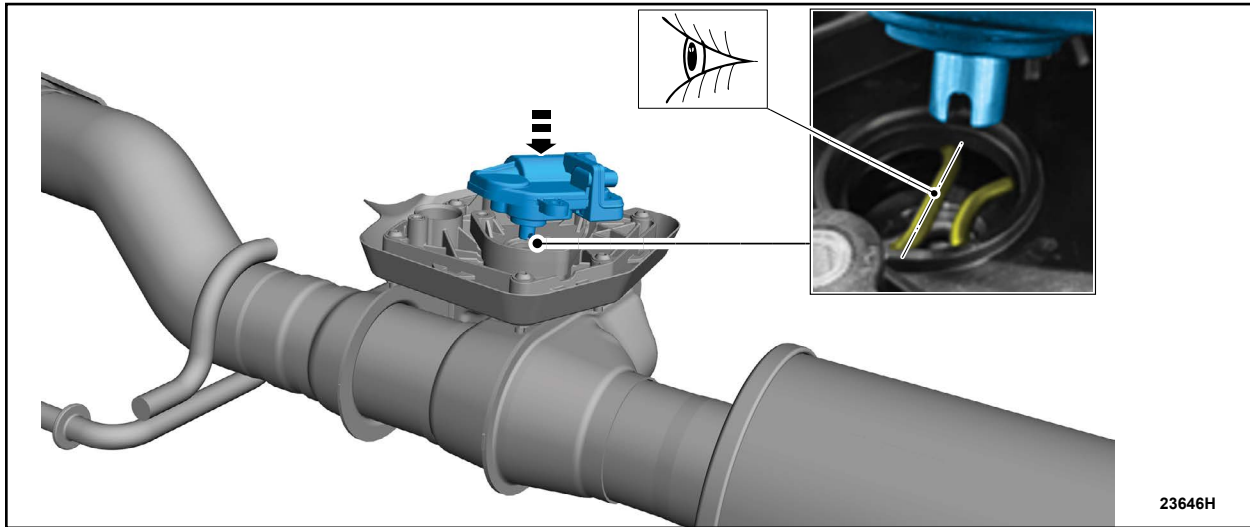

FIGURE 8

9. Align the bolt holes and install the bolts. See Figure 9.

NOTE: Only tighten the bolts finger tight at this stage.

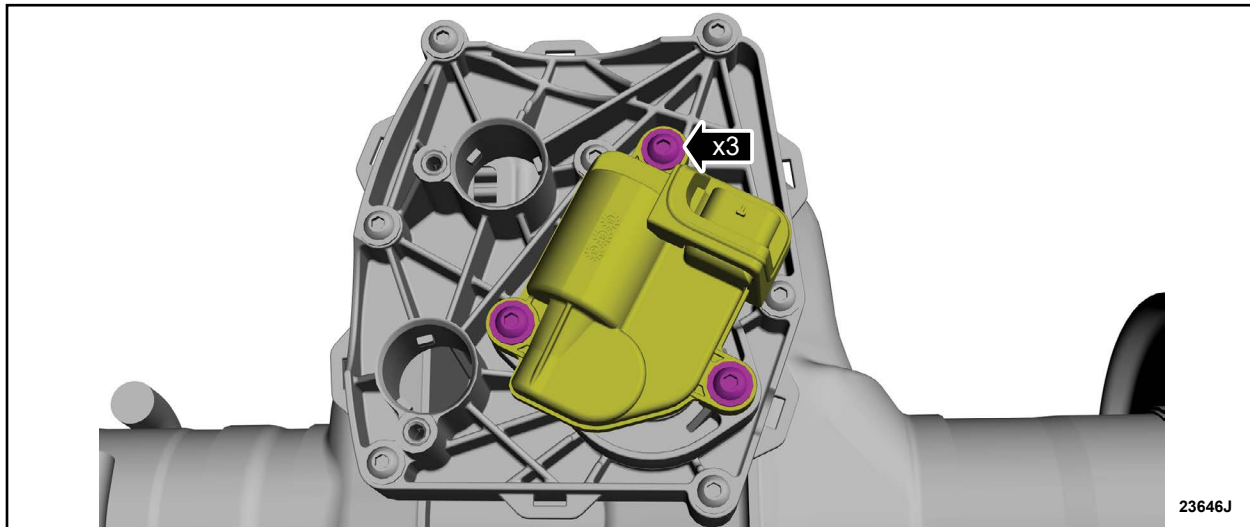

FIGURE 9



10. Torque the bolts in the sequence shown. See Figure 10.

- Torque: 71 lb.in (8Nm)

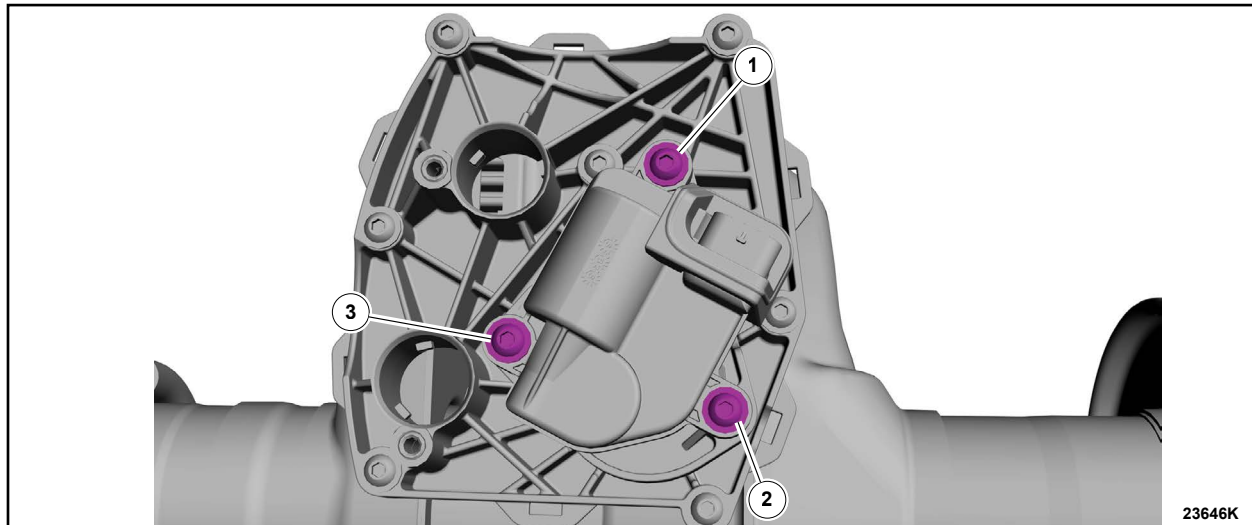

FIGURE 10

11. Install the cover. See Figure 11.

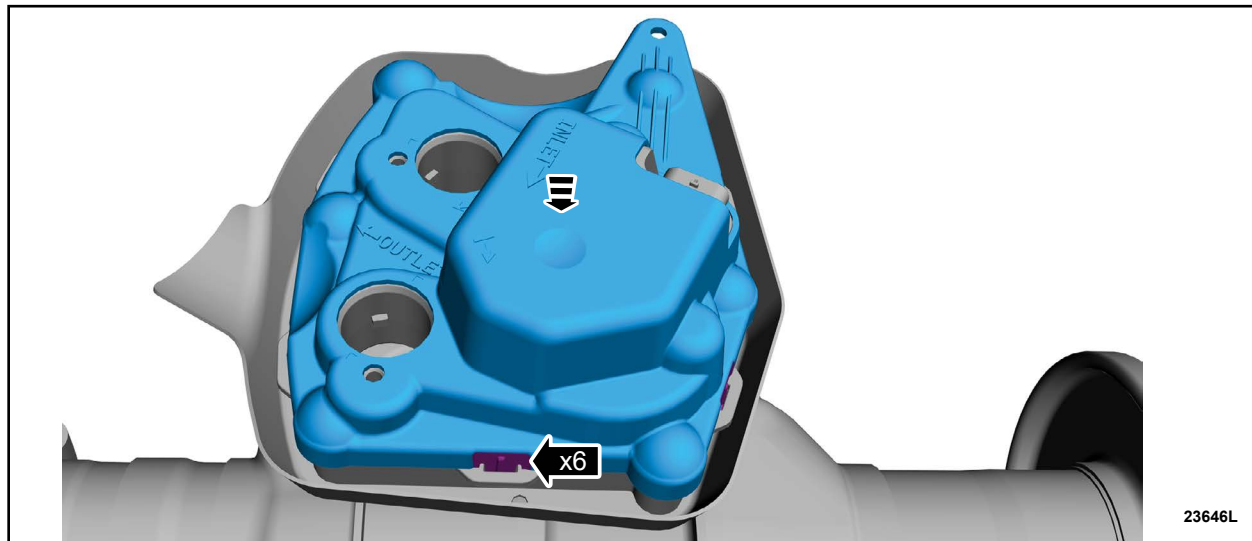

FIGURE 11



12. Connect the electrical connector and install the wire retainer. See Figure 12.

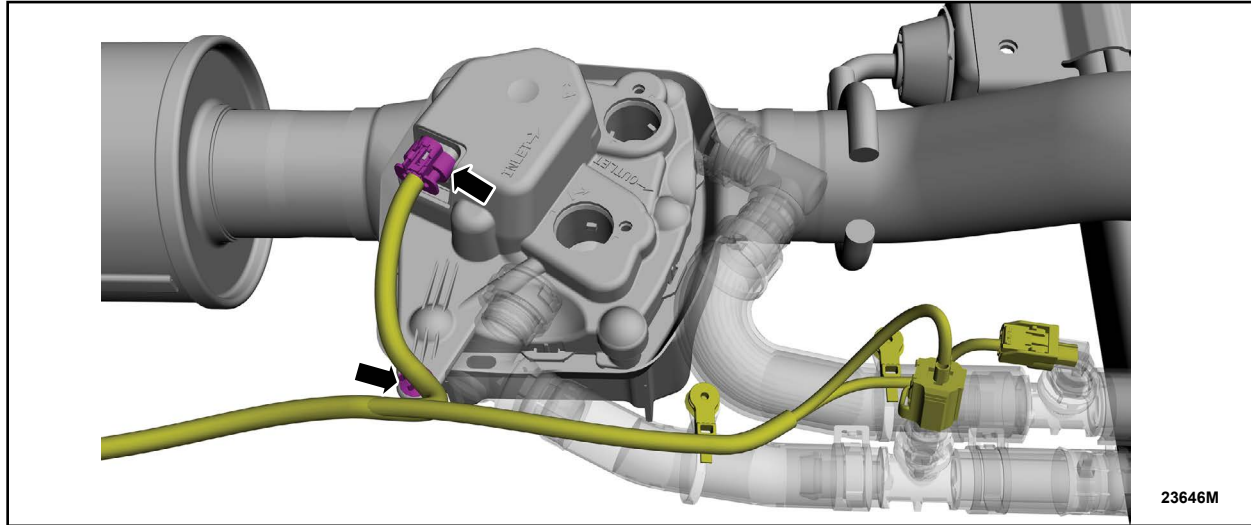

FIGURE 12

13. Unclamp the heat exchanger coolant spigots. See Figure 13.

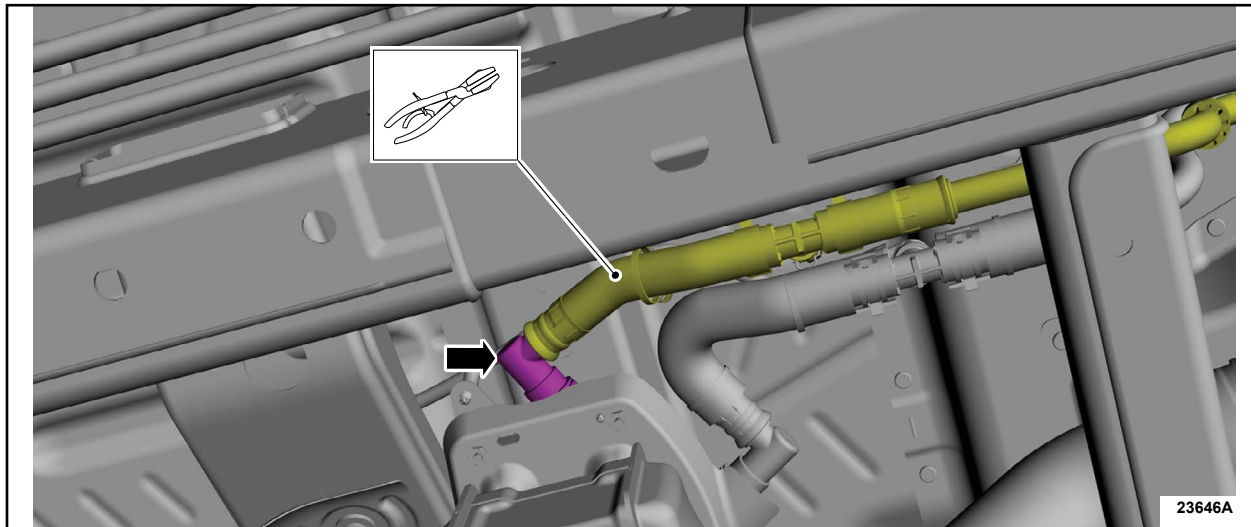

FIGURE 13



14. Check the coolant level and fill to the required level. Follow the procedures in WSM Manual Section 309-03D.

15. Proceed to **FDRS ALIGNMENT PROCEDURE** below.

FDRS ALIGNMENT PROCEDURE

1. In FDRS click on the **Data Logger** tab.

2. In the PID Search bar type: *ehe_ebva*, then click the Search Icon. See Figure 14.

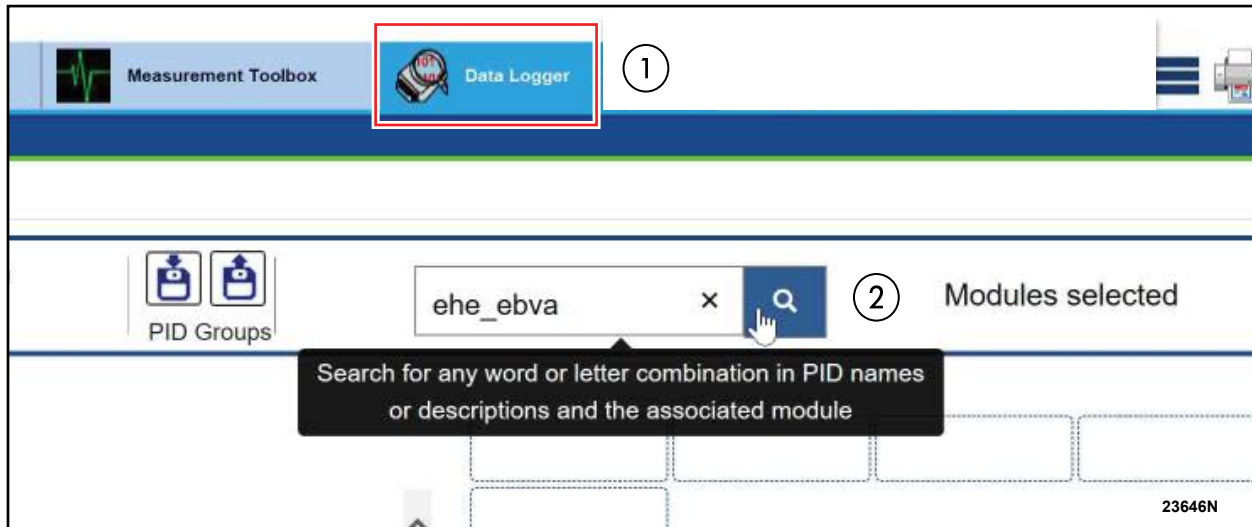

FIGURE 14



3. Command EHE_EBVA_CTRL_DC # from 5% to 95%. See Figure 15.

NOTE: Ensure to command the signal down to 5% or it could cause the alignment indication to show as not valid.

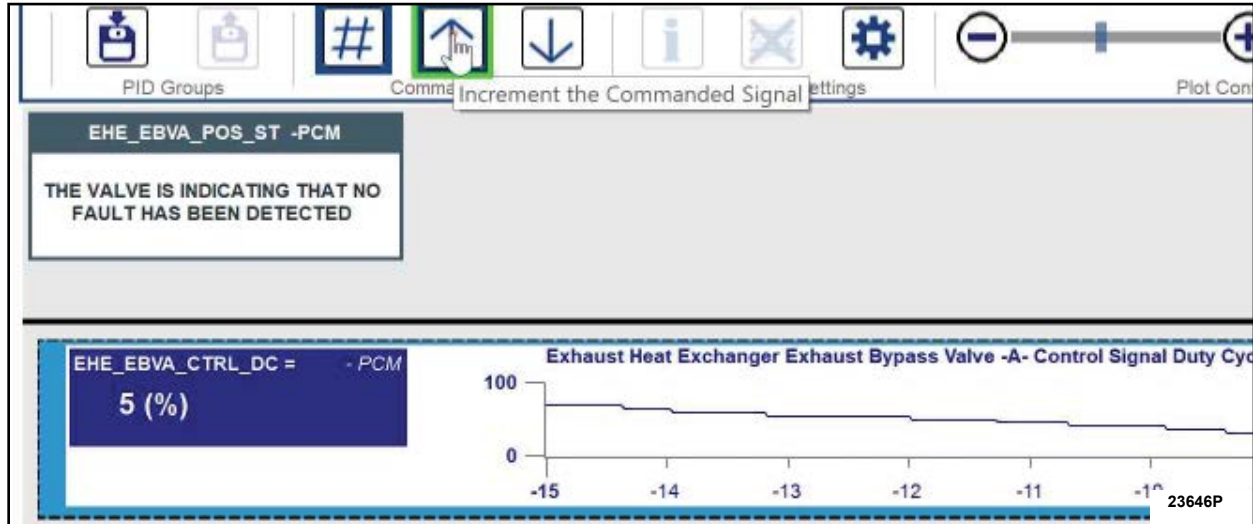

FIGURE 15

4. Monitor the EHE_EBVA_POS_ST. A statement of alignment successful will display.

5. If EHE_EBVA_POS_ST indicates the alignment is not valid, then repeat the **FDRS ALIGNMENT PROCEDURE**.

IMPORTANT NOTE: Federal law prohibits selling motor vehicle parts or components that are under safety, compliance, or emissions recall. Unless a part is requested to be returned to Ford, all parts replaced under this FSA must be scrapped in accordance with all applicable local, state and federal environmental protection and hazardous material regulations. Refer to the Parts Retention, Return, & Scrapping section of the FSA dealer bulletin for further information.

