



Service Engineering Operations  
Customer Service Division

Ford Motor Company  
PO Box 1904  
Dearborn, Michigan 48121

December 17, 2024

**TO:** All U.S. Ford and Lincoln Dealers

**SUBJECT:** **Customer Satisfaction Program 24B68**  
Certain 2024-2025 Model Year Econoline Vehicles  
Transmission Selector Lever Cable Inspection

### **PROGRAM TERMS**

This program will be in effect through December 31, 2025. There is no mileage limit for this program.

### **AFFECTED VEHICLES**

<b>Vehicle</b>	<b>Model Year</b>	<b>Assembly Plant</b>	<b>Build Dates</b>
Econoline	2024-2025	Ohio Assembly	July 18, 2022, through September 29, 2023

US population of affected vehicles: 33,744. Affected vehicles are identified in OASIS and FSA VIN Lists.

**Note:** Some vehicles may be in the process of being repaired at the plant. Monitor OASIS before opening an RO and/or beginning a repair. Parts purchased for an FSA can be returned for credit if required. See the EXCESS STOCK RETURN details in Labor Allowances and Parts Ordering Information for more information.

### **REASON FOR THIS PROGRAM**

On some affected vehicles, the shifter cable may rest on the exhaust due to the degradation of the hold-down clip retainer, which may result in progressively higher shifting efforts over time due to damage to the shifter cable.

### **SERVICE ACTION**

Dealers are to resecure the shifter cable. This service must be performed on all affected vehicles at no charge to the vehicle owner.

### **OWNER NOTIFICATION MAILING SCHEDULE**

Owner letters are expected to be mailed the week of January 6, 2025, or sooner. Dealers should repair any affected vehicles that arrive at their dealerships, whether or not the customer has received a letter.

### **ATTACHMENTS**

- Administrative Information
- Labor Allowances and Parts Ordering Information
- Technical Instructions
- Mobile Service Repair Assessment
- Owner Notification

## **QUESTIONS & ASSISTANCE**

For questions and assistance, contact the Special Service Support Center (SSSC) via the SSSC Web Contact Site. The SSSC Web Contact Site can be accessed through the Professional Technician System (PTS) website using the SSSC link listed at the bottom of the OASIS VIN report screen or listed under the SSSC tab.

Customer Service Division

## Customer Satisfaction Program 24B68

### **MOBILE SERVICE REPAIR ASSESSMENT LEVEL**

- All repairs in this program have the following assessment level.  
Ⓢ - Not a Mobile Service Repair

### **OASIS ACTIVATION**

OASIS will be activated on December 17, 2024.

### **FSA VIN LISTS ACTIVATION**

FSA VIN Lists will be available through <https://web.fsavinlists.dealerconnection.com> on December 17, 2024. Owner names and addresses will be available by December 17, 2024.

**NOTE:** Your FSA VIN Lists may contain owner names and addresses obtained from motor vehicle registration records. The use of such motor vehicle registration data for any purpose other than in connection with this program is a violation of law in several states, provinces, and countries. Accordingly, you must limit the use of this listing to the follow-up necessary to complete this service action.

### **SOLD VEHICLES**

- Owners of affected vehicles will be directed to dealers for repairs.
- Immediately contact any of your affected customers whose vehicles are not on your VIN list but are identified in OASIS. Give the customer a copy of the Owner Notification Letter (when available) and schedule a service date.
- Correct other affected vehicles identified in OASIS brought to your dealership.
- Dealers are to prioritize repairs of customer vehicles over repairs of new and used vehicle inventory.

### **STOCK VEHICLES**

- Correct all affected units in your new vehicle inventory before delivery.
- Use OASIS to identify any affected vehicles in your used vehicle inventory.

### **BRANDED / SALVAGED TITLE VEHICLES**

Affected branded/salvaged title vehicles are eligible for this service action.

### **OWNER REFUNDS**

Refunds are not approved for this program.

### **RENTAL VEHICLES**

Rental vehicles are not approved for this program.

**Customer Satisfaction Program 24B68****ADDITIONAL REPAIR (LABOR TIME AND/OR PARTS)**

Additional repairs identified as necessary to complete the FSA should be managed as follows:

- For related damage and access time requirements, refer to the Warranty and Policy Manual / Section 6 – Ford & Lincoln Program Policies / General Information & Special Circumstances for FSAs / Related Damage.
- For vehicles within new vehicle bumper-to-bumper warranty coverage, no SSSC approval is required, although related damage must be on a separate repair line with the “Related Damage” radio button checked.
  - Ford vehicles – 3 years or 36,000 miles
- For vehicles outside new vehicle bumper-to-bumper warranty coverage, submit an Approval Request to the SSSC Web Contact Site before completing the repair.

**CLAIMS PREPARATION AND SUBMISSION**

- **Technician Competency Requirement:** The STST Competency 10 certification requirement in the U.S. market only will be enforced starting with repair orders opened on or after August 31, 2024. FSA repairs will be rejected and the claim will not be paid if the repairing technician is not certified in STST Competency 10 FSA. See EFC15332 for more details.
- **Claim Entry:** Enter claims using Dealer Management System (DMS) or One Warranty Solution (OWS) online.
  - When entering claims:
    - Claim type 31: Field Service Action
    - Sub Code: 24B68
    - Customer Concern Code (CCC): P51 - AT Difficult to operate shift lever.
    - Condition Code (CC): 30 – Chafed excess frayed
    - Causal Part Number: 00817, Quantity 0
  - For additional claims preparation and submission information, refer to the Recall and Customer Satisfaction Program (CSP) Repairs in the OWS User Guide.
- **Related Damage/Additional labor and/or parts:** Must be claimed as Related Damage on a separate repair line from the FSA with the same claim type and subcode as described in the Claim Entry above.

**IMPORTANT:** Click the Related Damage Indicator radio button.
- **Provision for Locally Obtained Supplies:** Includes Coroplast brand high-temperature abrasion tape. Submit on the same line as the repair.
  - Program Code: 24B68
  - Misc. Expense: OTHER
  - Misc. Expense: Claim up to \$10

Customer Satisfaction Program 24B68

**LABOR ALLOWANCES**

Description	Labor Operation	Labor Time
Reposition shifter cable.	24B68B	0.6 Hours

**PARTS REQUIREMENTS / ORDERING INFORMATION**

Service Part Number	Claim Quantity	Package Order Quantity	Number in Package	Description
FU5Z-14A594-H	2	2	1	Zip Tie – High Temperature Resistant
AU5Z-00817-B	2	2	1	Push Pin
NAI837X	As required misc. other			Coroplast® brand Tape (one roll will service several vehicles pkg of 6 roles) Available in the Rotunda RTTP program.

Order your parts requirements through normal order processing channels. To guarantee the shortest delivery time, an emergency order for parts must be placed.

**DEALER PRICE**

For the latest prices, refer to DOES II.

**EXCESS STOCK RETURN**

The excess stock returned for credit must have been purchased from Ford Customer Service Division by Policy Procedure Bulletin 4000.

**REPLACED FSA PARTS INSPECTION AND SIGN OFF**

Effective March 1<sup>st</sup>, 2021, all parts replaced as part of an FSA repair with a repair order open date of March 1<sup>st</sup>, 2021, or later must be inspected and signed off on the repair order by a member of your dealer’s fixed operations management team or an employee the task has been delegated to. If the task is to be delegated to a non-management employee, the employee needs to be someone other than the technician who completed the repair and needs to understand the importance of completing this task consistently and accurately.

- All parts replaced as part of an FSA repair should be returned to the parts department following the Warranty Parts Retention and Return Policies.
- Inspect the replaced parts to verify the FSA repair was completed.
- If the FSA repair is found to be complete, the designated employee signs the repair order line or parts return stamp area (electronic or hand-signed) for the FSA repair indicating the parts were inspected and validated to have been replaced.
- After the parts have been inspected, they should be handled based on the guidance in the parts status report in the Online Warranty System (Hold, Return, CORE, Scrap, etc.). Please visit FMCDEALER > PARTS & SERVICE > WARRANTY ADMINISTRATION & WARRANTY PARTS RETURN for the latest [Immediate Scrap List](#) information.

Customer Satisfaction Program 24B68

**REPLACED FSA PARTS INSPECTION AND SIGN OFF (continued)**

- This process is subject to review during warranty audits for FSA repairs with a repair order open date of March 1<sup>st</sup> 2021, or later. Any eligible FSA claims requiring parts replacement found not to have been inspected and signed off during a warranty audit will be subject to chargeback and consideration for enrollment into the Dealer Incomplete Recall Repair Process.

**Note:** Other approvals (electronic or handwritten) for add-on repair lines, dealer-owned vehicle repairs, and repeat repairs do not qualify as FSA parts inspection approvals. The post-repair FSA parts inspection process (electronic or handwritten) is independent of other warranty approval requirements. The approval by the designated employee implies that the FSA parts were found to be replaced and must be able to be identified on the Repair Order. If multiple FSAs require approval on a single Repair Order, each applicable occurrence will require individual post-repair approval by the designated employee.

## CERTAIN 2024-2025 MODEL YEAR ECONOLINE VEHICLES — TRANSMISSION SELECTOR LEVER CABLE INSPECTION

### INSPECTION PROCEDURE

**IMPORTANT!** The Service Technician Specialty Training (STST) Competency 10 certification requirement, in the U.S. market only, will be enforced starting with repair orders opened on or after August 31, 2024. Field Service Action (FSA) repairs will reject and the claim will not be paid if the repairing technician is not certified in STST Competency 10 FSA. See Electronic Field Communication (EFC) 15332 for more details.

**NOTE:** Figure 1 shows the area for the following inspection.

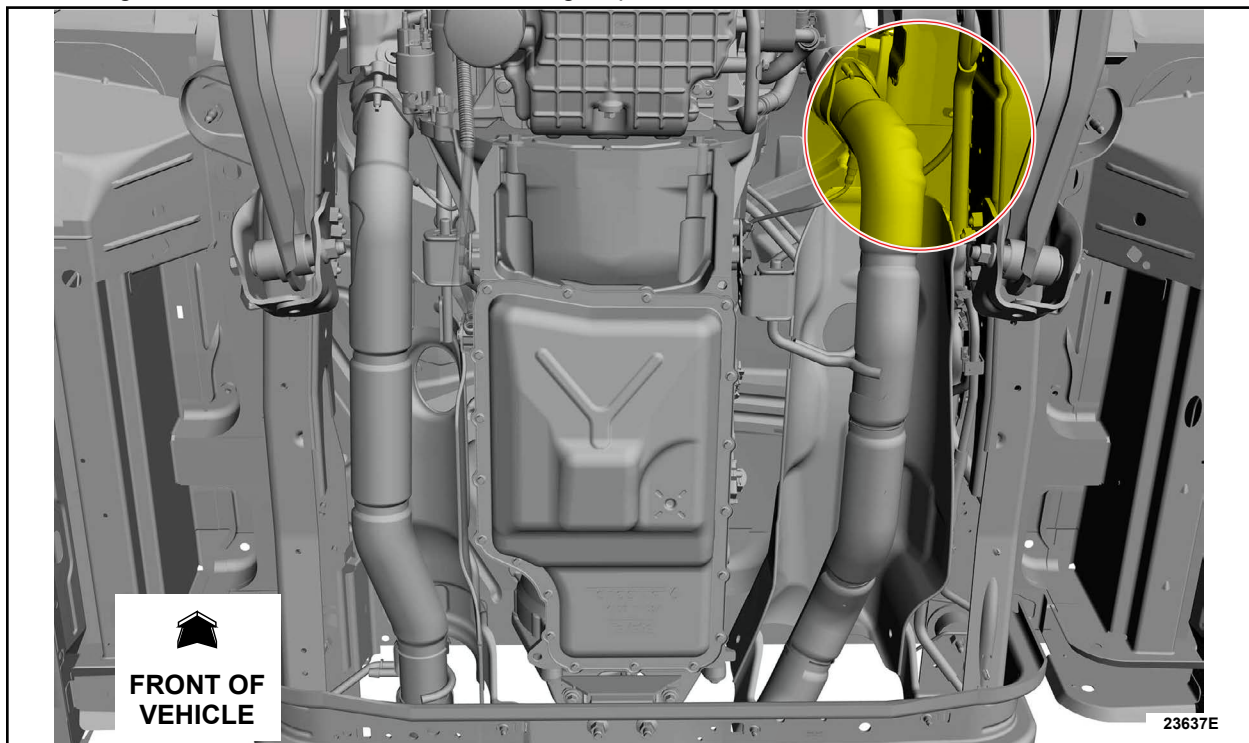

**FIGURE 1**



1. With the vehicle in Neutral (N), position it on a hoist. Follow the Workshop Manual (WSM) procedures in Section 100-02
2. Inspect the transmission selector lever cable retaining clip and protective heat shield, in the location shown in Figures 1 and 2. Has the selector lever cable retainer become detached from the plastic bracket (attached to the main underbody wiring harness) and has the cable protective heat shield been melted/damaged due to contacting the exhaust system?

**Yes** - Contact the Special Service Support Center (SSSC) to order a *new* transmission selector lever cable. Then, install the *new* transmission selector lever cable by following the Workshop Manual (WSM) procedures in Section 307-05 and then, perform the SERVICE PROCEDURE on Page 3.

**No** - Proceed to the SERVICE PROCEDURE on Page 3.

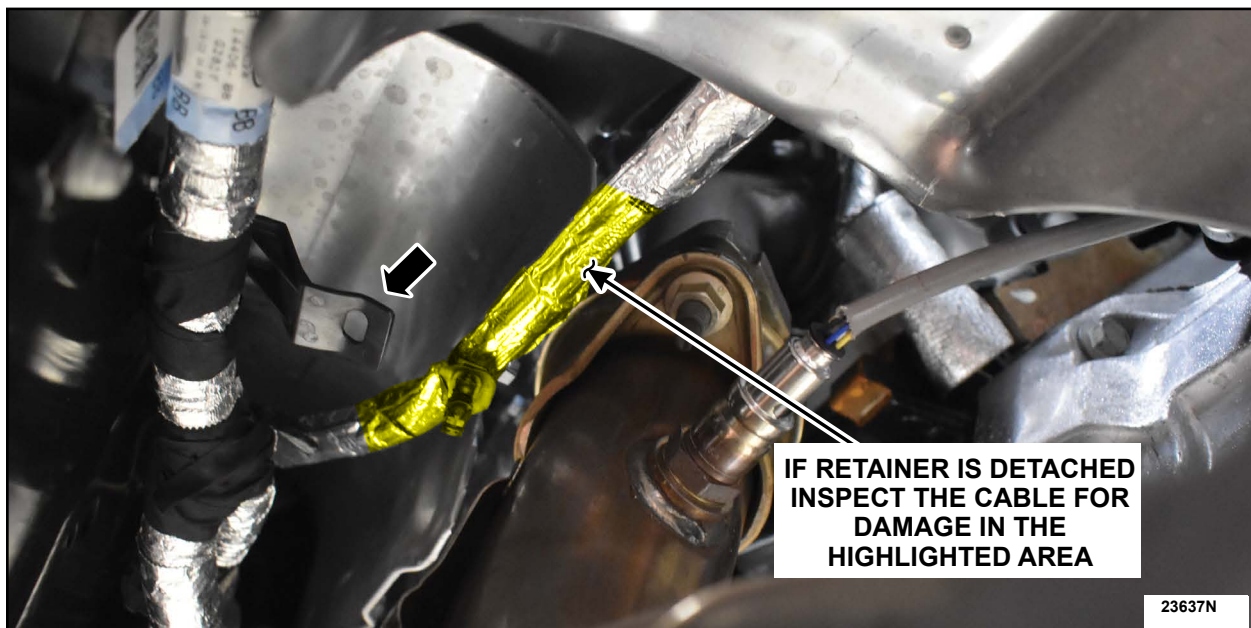
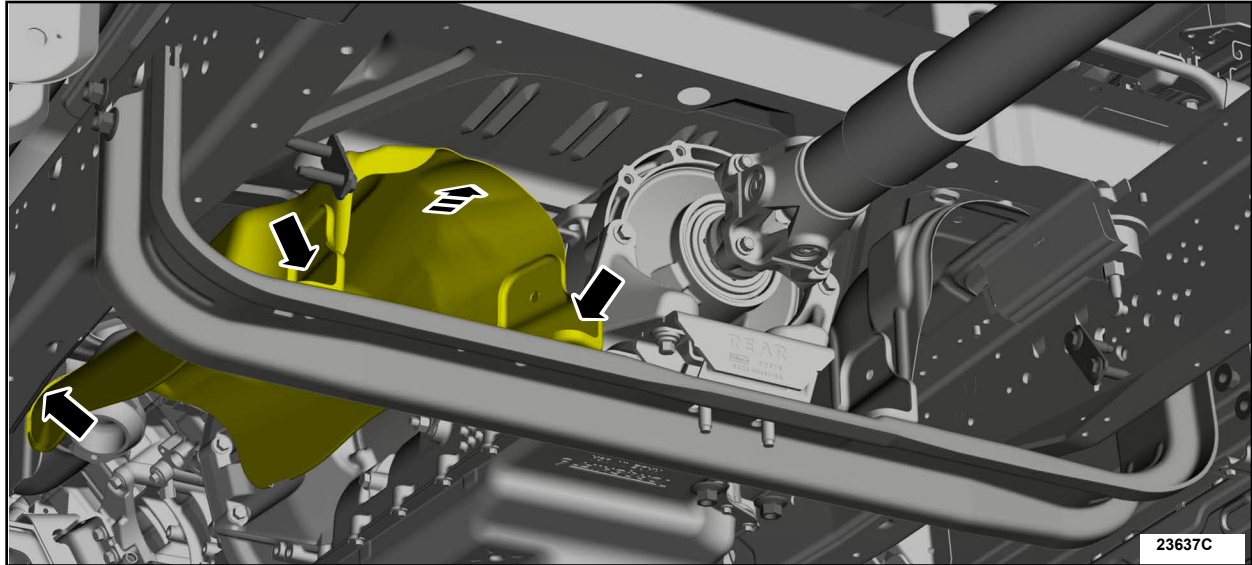

FIGURE 2



## SERVICE PROCEDURE

1. Remove the three (3) retainers and position the exhaust heat shield rearward, over the transmission support crossmember. See Figure 3.



**FIGURE 3**

2. Detach two of the white, main underbody wiring harness, frame-mounted clips. One forward of the main wiring harness part number tag and one rearward as shown in Figure 4.

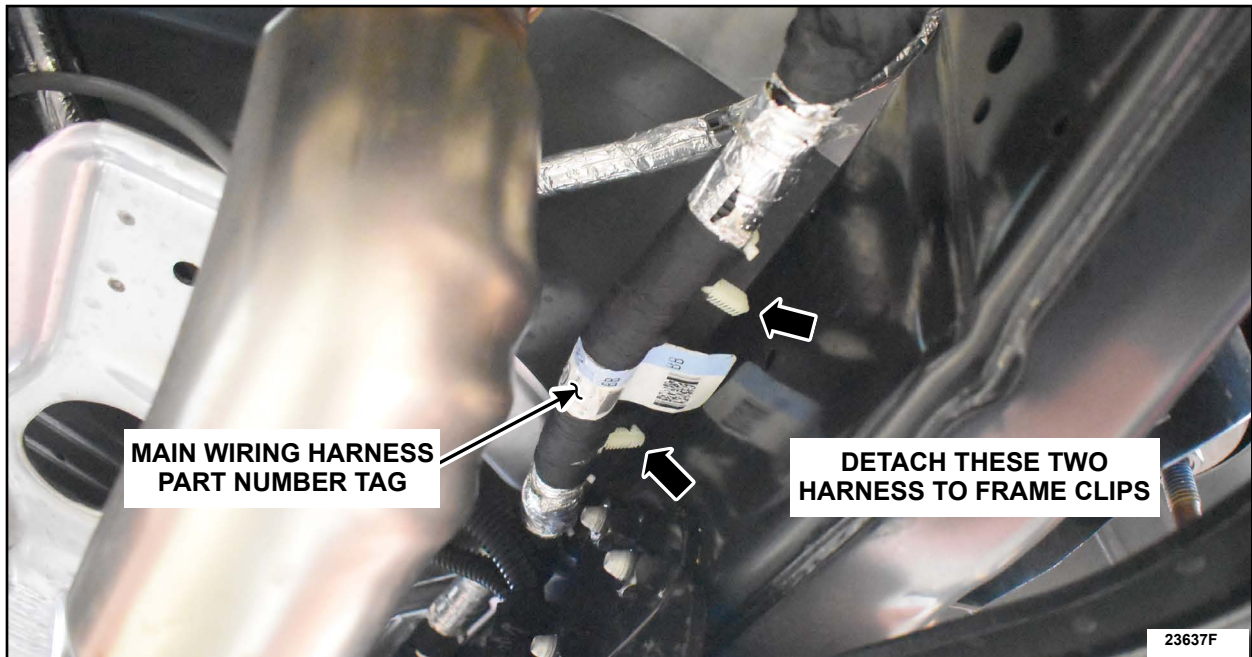

**FIGURE 4**



3. If still attached, detach the selector lever retainer from the plastic bracket on the main underbody wiring harness. Then, using a cutting tool, cut the tape and remove the plastic bracket retainer holder, from the main underbody wiring harness. **Note** the forward harness to frame clip will also be removed at the same time. See Figure 5.

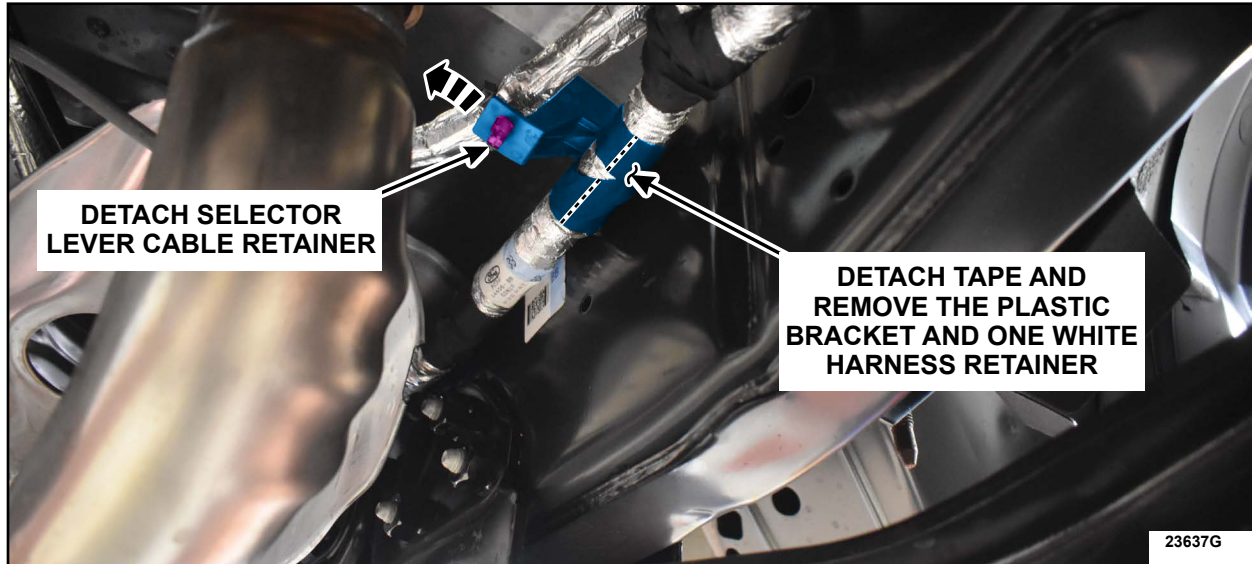

FIGURE 5

4. Using a cutting tool, cut the tape and remove the rearward white clip, from the main underbody wiring harness, that was released from the frame, as shown in Figure 6.

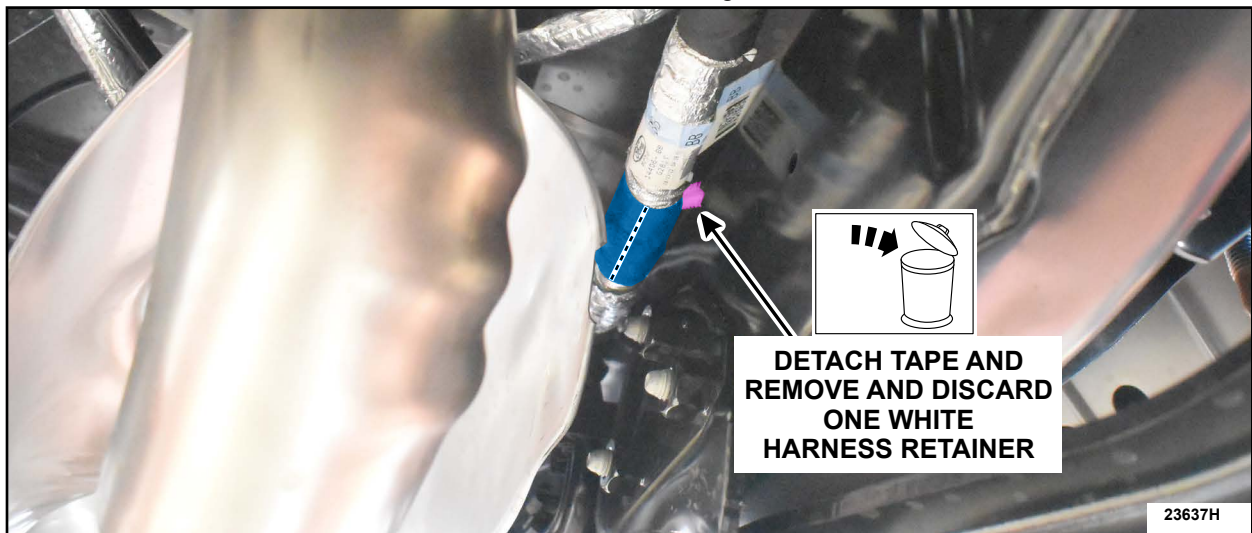

FIGURE 6



5. Wrap Coroplast® tape around the harness, including the frame rail clips that were removed in the previous steps, on both sides of the part number tag as shown in Figure 7.

**NOTE:** Make sure the protective heat shields are facing inboard toward the hot components.

**NOTE:** Make sure to cover any cuts/tears on the protective heat shield with Coroplast® tape.

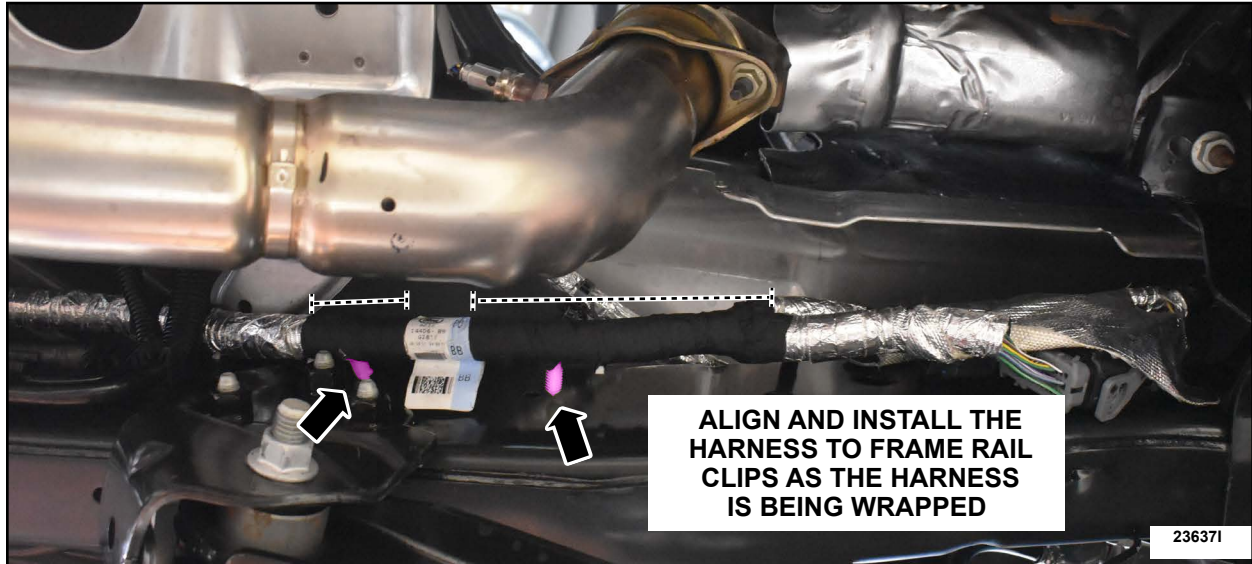
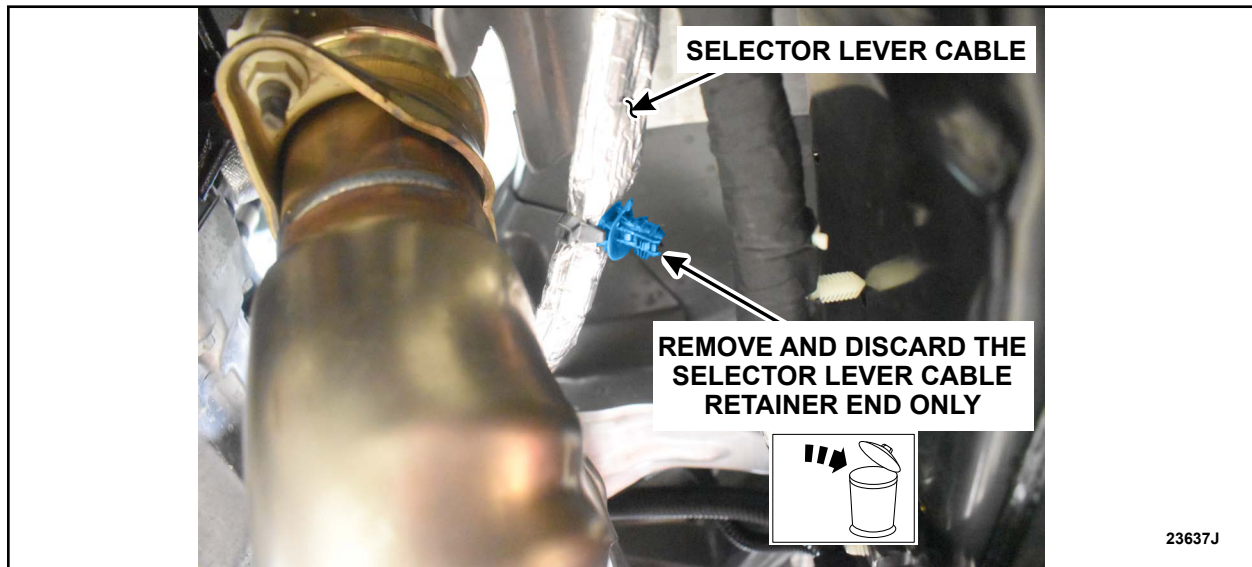

**FIGURE 7**

6. Remove and discard the retainer end only on the selector lever cable. See Figure 8.

**NOTE:** Do not attach the main underbody wiring harness to the frame at this time.

**NOTE:** Make sure to leave the zip tie portion of the selector lever cable retainer attached to the cable.



**FIGURE 8**



7. Position the selector lever cable back over the main underbody wiring harness and loosely install both *new* zip ties on either side of the part number tag. See Figure 9.

**NOTICE:** The use of standard zip ties run the risk of melting, losing strength, and aging rapidly. Use Only the specified heat rated zip ties referenced in the Dealer Bulletin.

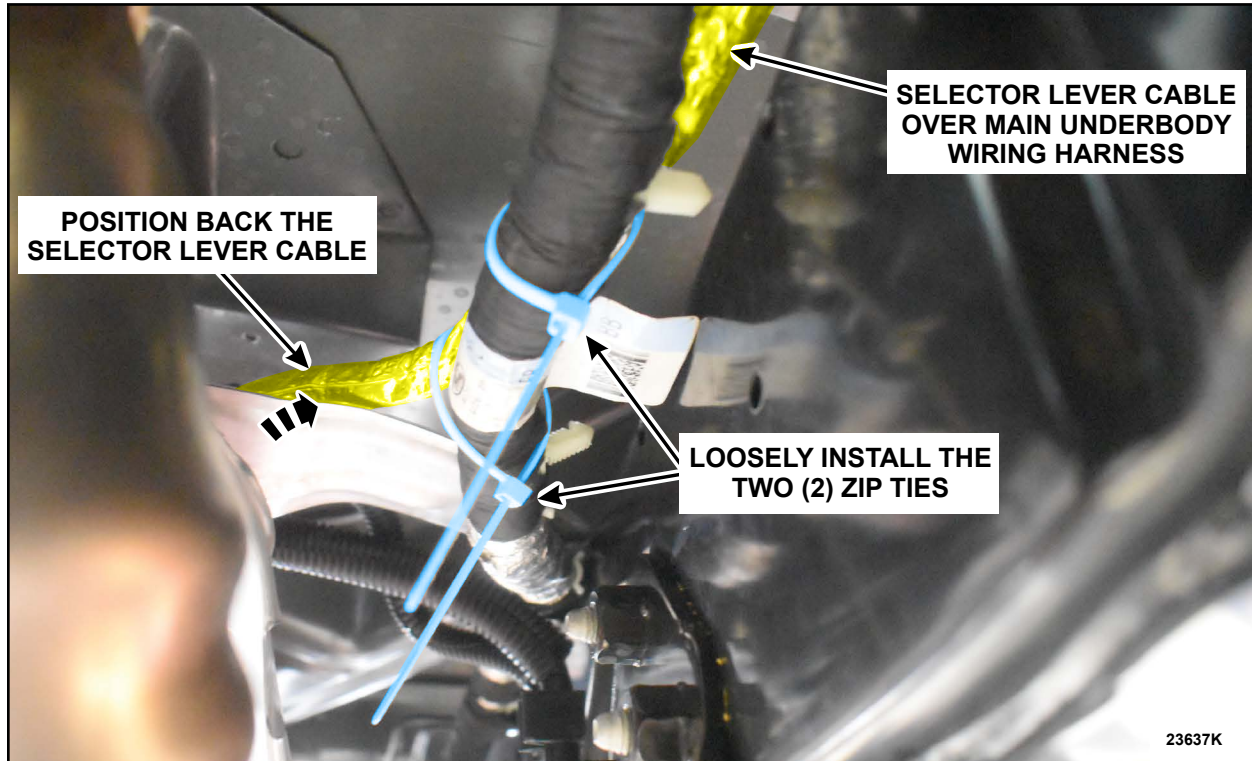

FIGURE 9

8. Attach both *new* clips into their original locations in the frame. See Figure 10.

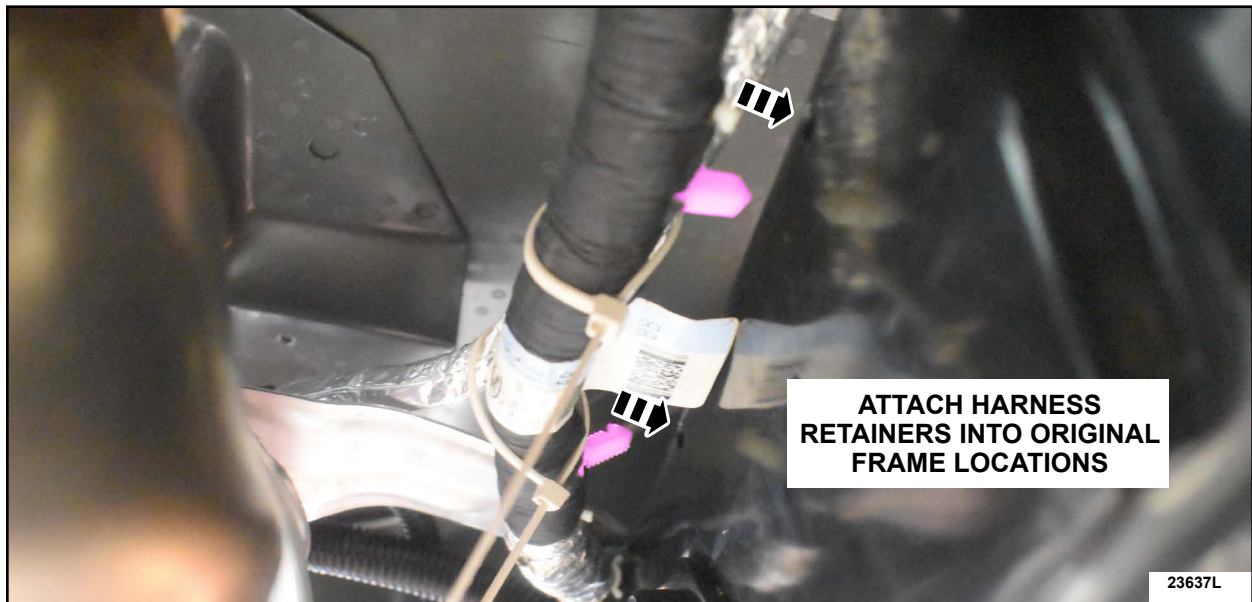

FIGURE 10



9. Make sure the selector cable is on top of the wiring harness and the heat shield is facing hot components. Then, secure the zip ties and cut off the ends. See Figure 11.



**FIGURE 11**

10. Position back the exhaust heat shield and install the retainers. See Figure 3.

- Torque: 14.7 lb. ft (20 Nm).

**IMPORTANT NOTE:** Federal law prohibits selling motor vehicle parts or components that are under safety, compliance, or emissions recall. Unless a part is requested to be returned to Ford, all parts replaced under this FSA must be scrapped in accordance with all applicable local, state and federal environmental protection and hazardous material regulations. Refer to the Parts Retention, Return, & Scrapping section of the FSA dealer bulletin for further information.



**Customer Satisfaction Program 24B68**  
 Certain 2024-2025 Model Year Econoline  
 Transmission Selector Lever Cable Inspection







**Mobile Service Repair Assessment**

Assessment levels have been identified to help determine the ease of performing eligible mobile service repairs for a Field Service Action (FSA) outside of the dealership service facility.

**Dealer Bulletin**

Within the Administrative Information Attachment of the dealer bulletin a mobile service repair assessment level(s) will be provided. These assessment levels have been determined using the amount of time, equipment and labor identified to perform the intended service action.

**Assessment Levels**

-  - Mobile Reprogramming (MRA1)
-  - Light Mobile Service (MRA2)
-  - Enhanced Mobile Service (MRA3)
-  - Advanced Mobile Service (MRA4)
-  - Not a Mobile Service Repair (MRA5)
-  - Wheel and Tire Mobile Service (MRA6)
-  - Advanced Driver Assistance System (ADAS) Mobile Repair (MRA7)

**Description of each level that is used to determine the overall assessment.**

-  – Mobile Reprogramming (MRA1)
  - Module Programming or similar type services
  - Minimum tools maybe required other than an **IDS/FDRS** setup
  - FDRS programming that requires internet connection (wi-fi or mobile hotspot)
  - Make sure vehicle has a charge port to ensure battery voltage is maintained during flashing of the module(s)
  - Repairs not greater than 1 hour in length (including time to wait for programming)

*Note: The location will need a charging station or wall box to maintain the 12-volt battery.*
-  – Light Mobile Service (MRA2)
  - Interior repair procedures that do not require seat, dash, or headliner removal
  - Under hood repairs that do not require large component removal
  - Exterior repairs that do not require large component/panel removal
  - Repairs may require standard hand tools (Access to a Technician starter kit or similar)

**Customer Satisfaction Program 24B68**  
Certain 2024-2025 Model Year Econoline  
Transmission Selector Lever Cable Inspection

   – Enhanced Mobile Service (MRA3)

- **A two-person process is required anytime a procedure requires work under the vehicle**
- Brake Inspection and Brake Repair/Replacement
- Limited Suspension Component replacement (no alignment)
- Under Vehicle access for limited repairs (no large component removal)
- Vehicle Check Up - VCU
- Pre-Delivery Inspection - PDI
- Used Car Inspection/Presale Inspection
- May require floor jack, jack stands, and impact tools

*Note: Wheel lock may be required.*

    – Advanced Mobile Service (MRA4)

- Fluid Exchange/Oil Change
- Light Repairs
- Brake Hydraulic Repairs

 – Not a Mobile Service Repair (MRA5)

1. Large component removal
2. BEV Battery Replacement
3. Requires a vehicle hoist – to complete the repair (more than inspection)
4. Required vehicle alignment
5. Requires significant vehicle disassembly
6. Repairs greater than 2-3 hours
7. Any repairs that require M-Time
8. Includes a service procedure where the vehicle owner may be distressed about the state of their vehicle.

 – Wheel and Tire Mobile Service (MRA6)

- Tire Removal from Wheel
- Tire Balancing
- Tire Repair

*Note: Specialized Mobile Service unit and equipment including Tire balancer and Tire Changer required.*

 – Advanced Driver Assistance System (ADAS) Mobile Repair (MRA7)

- Requires the uses of a ADAS Mobile Service Kit.
- May require a post repair test drive.
  - Parking Lot Maneuvers to capture parking lines for camera alignment.
  - Steady speed cruising (45 MPH).
- **The vehicle service location will have to be validated before scheduling an appointment to determine if a mobile repair is appropriate.**



Ford Motor Company  
Customer Service Division  
PO Box 1904  
Dearborn, Michigan 48121

December 2024

Customer Satisfaction Program 24B68

Mr. John Sample  
123 Main Street  
Anywhere, USA 12345

12345678901234567

At Ford Motor Company, we are committed not only to building high-quality, dependable products but also to building a community of happy, satisfied customers. To demonstrate that commitment, we are providing a no-charge Customer Satisfaction Program for your vehicle.

**Why are you receiving this notice?** On your vehicle, it may be possible the shifter cable may rest on the exhaust due to the degradation of the hold-down clip retainer.

**What is the effect?** This may result in progressively higher shifting efforts over time due to damage to the shifter cable.

**What will Ford and your dealer do?** **Parts are now available to repair your vehicle.** In the interest of customer satisfaction, Ford Motor Company has authorized your dealer to resecure the shifter cable free of charge under the terms of this program. This Customer Satisfaction Program will be in effect until December 31, 2025, regardless of mileage. Coverage is automatically transferred to subsequent owners.

**How long will it take?** The time needed for this repair is less than half a day. However, due to service scheduling requirements, your dealer may need your vehicle for a longer period. Additional time may be required to allow the engine to cool before performing this repair. In addition, your vehicle will require an inspection to determine if additional parts need to be ordered.

**What should you do?** Please call your dealer without delay to schedule a service appointment for Customer Satisfaction Program 24B68. If you do not already have a servicing dealer, you can access [ford.com/support](https://ford.com/support) for dealer addresses, maps, and driving instructions. Ford Motor Company wants you to have this service action completed on your vehicle. The vehicle owner is responsible for making arrangements to have the work completed. Ford Motor Company can deny coverage for any vehicle damage that may result from the failure to have this service action

**What should you do?  
(continued)**

performed on a timely basis. Therefore, please have this service action performed as soon as possible.

NOTE - You can receive information about Recalls and Customer Satisfaction Programs through our FordPass App. The app can be downloaded through the App Store or Google Play. In addition, there are other features such as reserving parking in certain locations and controlling certain functions on your vehicle (lock or unlock doors, remote start) if it is equipped to allow control.

**What if you no longer own this vehicle?**

If you no longer own this vehicle and have an address for the current owner, please forward this letter to the new owner.

You received this notice because our records, which are based primarily on state registration and title data, indicate that you are the current owner.

**Can we assist you further?**

If you have difficulties getting your vehicle repaired promptly and without charge, please contact your dealership's Service Manager for assistance.

**RETAIL OWNERS:** If you have questions or concerns, please contact our **Ford Customer Relationship Center (CRC) at 1-866-436-7332** and one of our representatives will be happy to assist you. The CRC is open on weekdays from 8:00 AM – 11:00 PM and on Saturday from 8:00 AM - 8:00 PM (Eastern Time). TTY/TDD users, please contact the CRC at the number listed using the Telecommunication Relay Service by dialing 711.

If you wish to contact us through the internet, our address is [ford.com/support](http://ford.com/support).

**FLEET OWNERS:** If you have questions or concerns, please contact our **Ford Pro Contact Center at 1-800-34-FLEET**, choose Option #1, and one of our representatives will be happy to assist you. If you wish to contact us through the Internet, our address is [fleet.ford.com](http://fleet.ford.com).

Representatives are available Monday through Friday: 7:00 AM – 11:00 PM and Saturday 7:00 AM – 5:00 PM (Eastern Time).

**MOTORHOME OWNERS:** If you have questions or concerns, please contact our **Motorhome Customer Assistance Center toll-free at 1-866-906-9811**. Representatives are available 24 hours a day.

Thank you for your attention to this important matter.

Customer Service Division



Ford Motor Company  
División de Servicio al Cliente  
PO Box 1904  
Dearborn, Michigan 48121

Diciembre 2024

Programa de satisfacción del cliente 24B68

Sr. Juan Pérez  
Calle Principal 123  
Ciudad, EE. UU. 12345

12345678901234567

El compromiso de Ford Motor Company no es solo fabricar productos confiables y de alta calidad, sino que también lograr la plena satisfacción del cliente. Para demostrar este compromiso, estamos proporcionando un programa de satisfacción del cliente sin cargo para su vehículo.

**¿Por qué recibe este aviso?**

Es posible que el cable de la palanca de cambios descansa sobre el escape debido a la degradación del retenedor del clip de sujeción.

**¿Cuál es el efecto?**

Esto podría requerir esfuerzos de cambio progresivamente mayores con el tiempo, debido a daños en el cable de la palanca de cambios.

**¿Qué medidas adoptarán Ford y su concesionario?**

**Las piezas para reparar su vehículo ya se encuentran disponibles.** Para satisfacer a nuestros clientes, Ford Motor Company ha autorizado a su concesionario a reasegurar el cable de la palanca de cambios sin costo alguno, conforme a los términos de este programa.

Este Programa de satisfacción del cliente estará vigente hasta el 31 de diciembre de 2025, independientemente del millaje. La cobertura se transferirá automáticamente a los siguientes propietarios.

**¿Cuánto tiempo tomará?**

El tiempo necesario para esta reparación será menos de medio día. Sin embargo, debido a los requisitos de planificación de servicio, es posible que su concesionario tarde un poco más. Es posible que se necesite más tiempo para permitir que el motor se enfríe antes de realizar esta reparación. Además, será necesario realizar una inspección a su vehículo para determinar si es necesario pedir piezas adicionales.

**¿Qué debe hacer?**

Llame a su concesionario lo antes posible para que programe una cita de servicio para realizar el Programa de satisfacción del cliente 24B68. Si aún no tiene un concesionario para realizar el servicio, puede acceder a [ford.com/support](https://ford.com/support) para conocer las direcciones de los concesionarios, ver mapas y obtener las instrucciones para llegar.

**¿Qué debe hacer?  
(continuación)**

Ford Motor Company le recomienda realizar esta acción de servicio en su vehículo. El propietario del vehículo es responsable de efectuar los arreglos necesarios para llevar a cabo el trabajo. Ford Motor Company puede negar la cobertura en caso de que el vehículo hubiese sufrido daños por no haber realizado la acción de servicio de manera oportuna. Por lo tanto, le solicitamos que realice esta acción de servicio lo antes posible.

NOTA: Puede recibir información sobre las campañas y los programas de satisfacción del cliente a través de la aplicación FordPass. La aplicación se puede descargar a través de App Store o Google Play. Adicionalmente, existen otras funciones como reserva de estacionamientos en determinados lugares, además de control de ciertas funciones en el vehículo (bloqueo o desbloqueo de puertas, arranque remoto) si así está equipado para permitir el control.

**¿Qué pasa si ya no es el propietario del vehículo?**

Si ya no es el propietario del vehículo y tiene la dirección del propietario actual, le solicitamos que le reenvíe esta carta.

Este aviso lo recibió porque en nuestros archivos, basados principalmente en datos de registro y propiedad de los EE. UU., aparece como el propietario actual.

**¿Podemos hacer algo más por usted?**

Si tiene problemas para reparar su vehículo de inmediato y sin costo alguno, comuníquese con el gerente de servicio de su concesionario para solicitar ayuda.

**PROPIETARIOS MINORISTAS:** Si tiene dudas o preguntas, comuníquese con nuestro **Centro de Relación con Clientes (CRC) Ford al 1-866-436-7332** y uno de nuestros representantes con gusto lo atenderá. El CRC está abierto de lunes a viernes de 8:00 a. m. a 11:00 p. m. y los sábados de 8:00 a. m. a 8:00 p. m. (hora del este). Si es usuario de TTY/TDD, comuníquese con el CRC al número que se menciona, mediante el servicio de retransmisión de telecomunicaciones, para esto, marque el 711.

Si desea comunicarse con nosotros a través de Internet, nuestra dirección es [ford.com/support](http://ford.com/support).

**PROPIETARIOS DE FLOTAS:** Si tiene dudas o preguntas, comuníquese con nuestro **Centro de contacto de Ford Pro al 1-800-34-FLEET**, elija la opción n.º 1 y uno de nuestros representantes con gusto lo atenderá. Si desea comunicarse con nosotros a través de Internet, nuestra dirección es [fleet.ford.com](http://fleet.ford.com).

Los representantes atienden de lunes a viernes, de 7:00 a.m. a 11:00 p.m. y sábado de 7:00 a.m. a 5:00 p.m. (hora del este).

**PROPIETARIOS DE CASAS RODANTES:** Si tiene dudas o preguntas, comuníquese con nuestro **Centro de Asistencia a Clientes de Casas Rodantes sin cargo al 1-866-906-9811**. Los representantes se encuentran disponibles las 24 horas del día.

Gracias por su atención en este asunto sumamente importante.

División de Servicio al Cliente