



# TECHNICAL SERVICE BULLETIN

## Equipped With Minor Feature Code HUKAJ - 400 Watt DC/AC Inverter System Inoperative With B1330:9A In The BCM

24-2443

20 December  
2024

This bulletin supersedes 24-2039. Reason for update: update the affected vehicles, the Service Procedure and the Parts List

### Model:

<b>Ford</b> 2021-2023 F-150	Equipped with minor feature code HUKAJ (400 watt DC/AC inverter system with a pickup bed AC power outlet socket)
--------------------------------	--

**Markets:** North American markets only

**Issue:** Some 2021-2023 F-150 non-Lightning vehicles equipped with the minor feature code HUKAJ (400 watt DC/AC inverter system with a pickup bed AC power outlet socket) may experience the DC/AC inverter system inoperative with DTC B1330:9A stored in the BCM. To confirm a vehicle is built with a certain minor feature code, review the build information by double-clicking the VIN in the upper left corner in the PTS. This may be due to a connection issue at C4628. To correct the condition, follow the Service Procedure to inspect the connector and secure the harness.

**Action:** Follow the Service Procedure to correct the condition if the vehicle meets all of the following criteria:

- 2021-2023 F-150 non-Lightning
- Minor feature code HUKAJ (400 watt DC/AC inverter system with a pickup bed AC power outlet socket)
- DC/AC inverter system inoperative with DTC B1330:9A stored in the BCM

**NOTE:** This article does not apply to vehicles with an inverter system other than the 400 watt DC/AC inverter system with a pickup bed AC power outlet socket.

### Parts

Service Part Number	Claim Quantity	Package Order Quantity	Number in Package	Description
8U5Z- 14A163-E	1	1	1	Retainer
XG-12	1	1	1	Motorcraft® Electrical Grease

### Parts - Parts To Inspect And Replace Only If Necessary

Service Part Number	Claim Quantity	Package Order Quantity	Number in Package	Description
MU5Z-19A464-A	Only If Necessary (1 Possible)	Only If Necessary (1 Possible)	1	Auxiliary Power Outlet
W716503-S300	Only If Necessary (Up To 8 Possible)	Only If Necessary (Up To 2 Possible)	4	Rear Fender Moulding Retainer (F-150 Raptor)
13A409	Only If Necessary (1 Possible)	Only If Necessary (1 Possible)	1	Wire Harness - Refer To The Parts Catalog For The VIN Specific Application

**Warranty Status:** Eligible under provisions of New Vehicle Limited Warranty (NVLW)/Service Part Warranty (SPW)/Service Part New Vehicle (SPNV)/Extended Service Plan (ESP) coverage. Limits/policies/prior approvals are not altered by a TSB. NVLW/SPW/SPNV/ESP coverage limits are determined by the identified causal part and verified using the OASIS part coverage tool.

## Labor Times

Description	Operation No.	Time
2021-2023 F-150, 2021-2023 F-150 Raptor/PowerBoost: Check DTCs, Disconnect C4628, Replace AC Power Outlet Socket Harness Retainer, Inspect Connector C4628, (Pass), Download And Run The BCM - Reset Battery Monitor Sensor Learned Values And BCM LIN New Module Initialization Check DTCs (Do Not Use With Any Other Labor Operations)	242443A	0.6 Hrs.
2021-2023 F-150: Check DTCs, Disconnect C4628, Replace AC Power Outlet Socket Harness Retainer, Inspect Connector C4628, (Fail), Replace Outlet Socket Assembly And 13A409 Body Harness Assembly, Download And Run The BCM - Reset Battery Monitor Sensor Learned Values And BCM LIN New Module Initialization Check DTCs (Do Not Use With Any Other Labor Operations)	242443B	1.7 Hrs.
2021-2023 F-150 Raptor: Check DTCs, Disconnect C4628, Replace AC Power Outlet Socket Harness Retainer, Inspect Connector C4628, (Fail), Replace Outlet Socket Assembly And 13A409 Body Harness Assembly, Download And Run The BCM - Reset Battery Monitor Sensor Learned Values And BCM LIN New Module Initialization Check DTCs (Do Not Use With Any Other Labor Operations)	242443C	2.2 Hrs.
2021-2023 F-150 3.5L PowerBoost: Check DTCs, Disconnect C4628, Replace AC Power Outlet Socket Harness Retainer, Inspect Connector C4628, (Fail), Replace Outlet Socket Assembly And 13A409 Body Harness Assembly, Download And Run The BCM - Reset Battery Monitor Sensor Learned Values And BCM LIN New Module Initialization Check DTCs (Do Not Use With Any Other Labor Operations)	242443D	1.9 Hrs.

## Repair/Claim Coding

Causal Part:	19A464
Condition Code:	43

## Service Procedure

1. Disconnect connector C4628 and remove the pickup bed AC power outlet socket harness retainer from the body located in Figure 1.

Figure 1

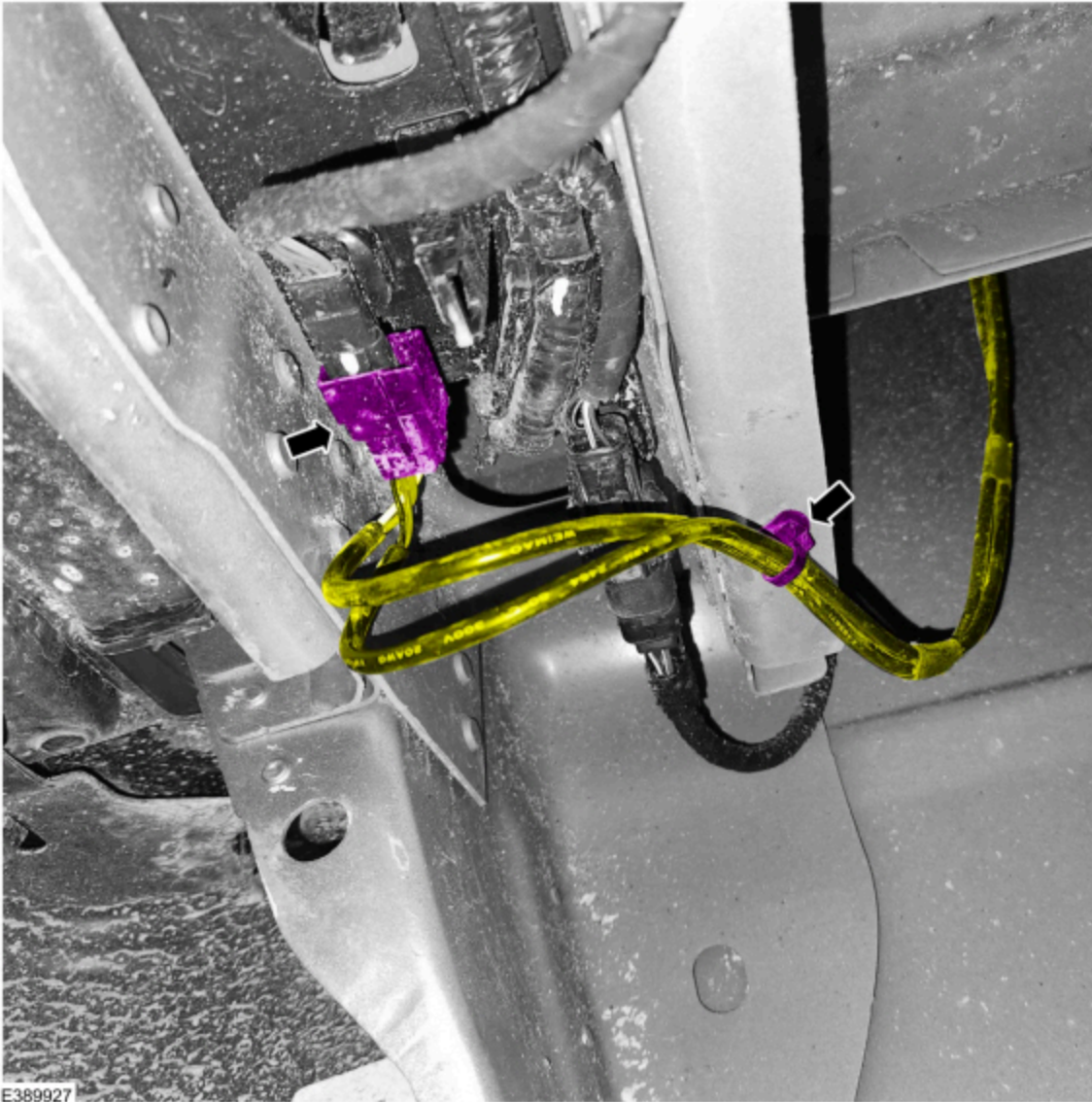

2. Using a suitable tool, carefully cut and remove the pickup bed AC power outlet socket harness retainer from the pickup bed AC power outlet socket harness. Discard the retainer.
3. Is the vehicle a Raptor?
  - (1). Yes - proceed to Step 4.
  - (2). No - proceed to Step 7.
4. For Raptor vehicles, inspect connector C4628 for the presence of corrosion, dirt and/or damage. Is corrosion, dirt and/or damage present in connector C4628? (Figure 2)

Figure 2

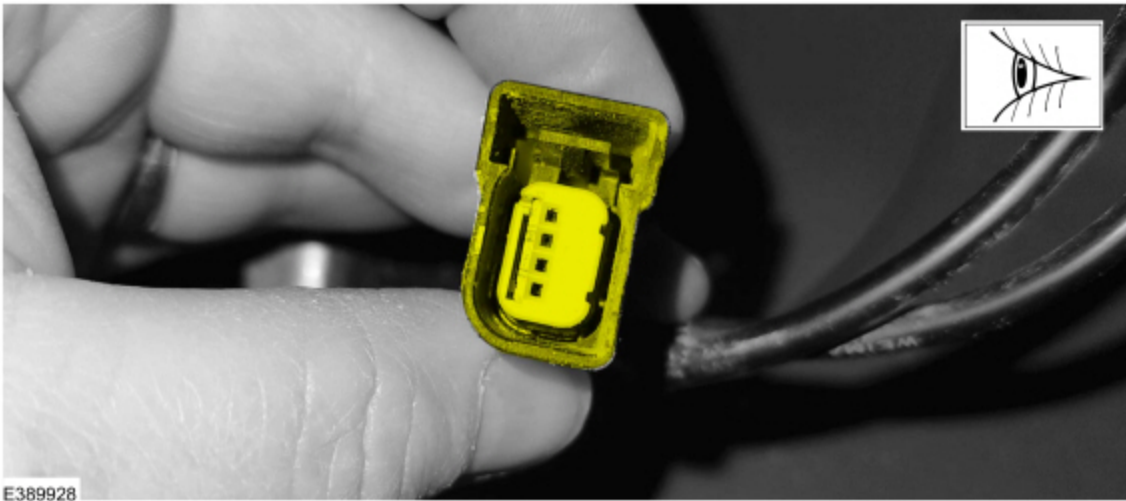

(1). Yes - proceed to Step 5.

(2). No - proceed to Step 8.

5. Replace the pickup bed AC power outlet socket assembly. Refer to WSM, Section 414-05. Proceed to Step 6.

6. Replace the body side harness assembly (13A409) of connector C4628. To gain access to the body side harness assembly (13A409), remove the left pickup bed lower moulding. Refer to WSM, Section 501-08 Exterior Trim and Ornamentation > Removal and Installation > Rear Quarter Panel Moulding. Then remove the three rearmost screws and the four rearmost retainers from the left rear fender moulding. (Figures 3-4) This will allow sufficient access to the remainder of the body side harness assembly (13A409). (Figure 5) Proceed to Step 8.

Figure 3

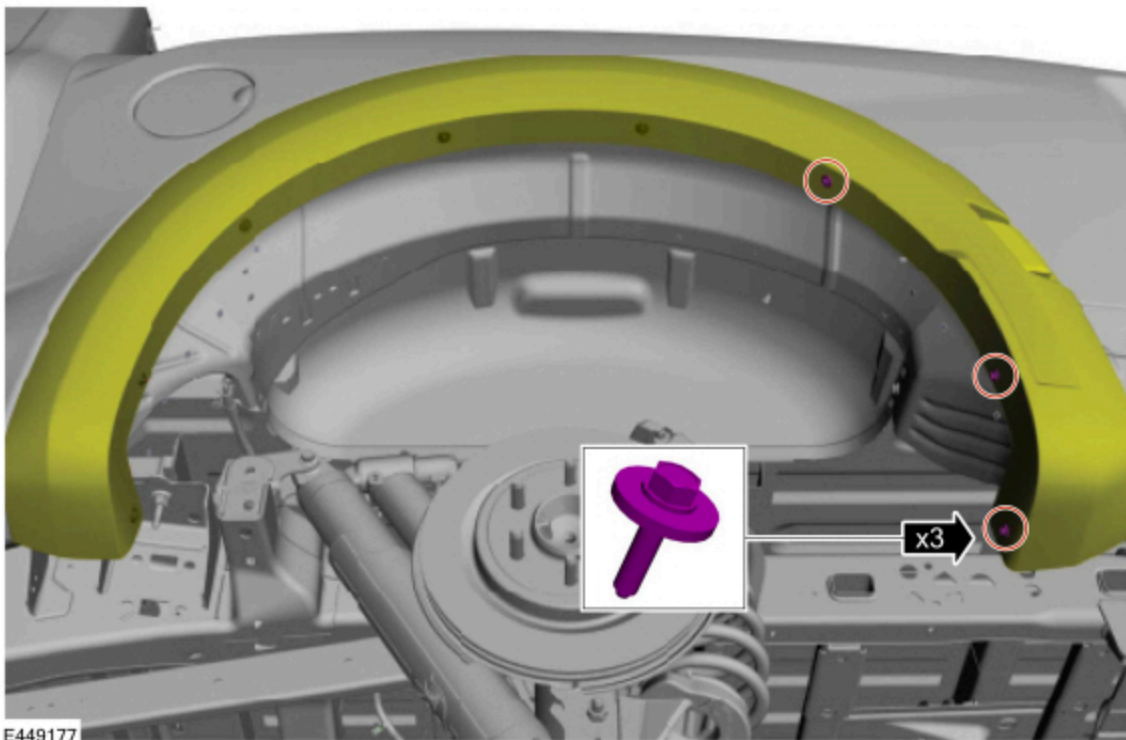
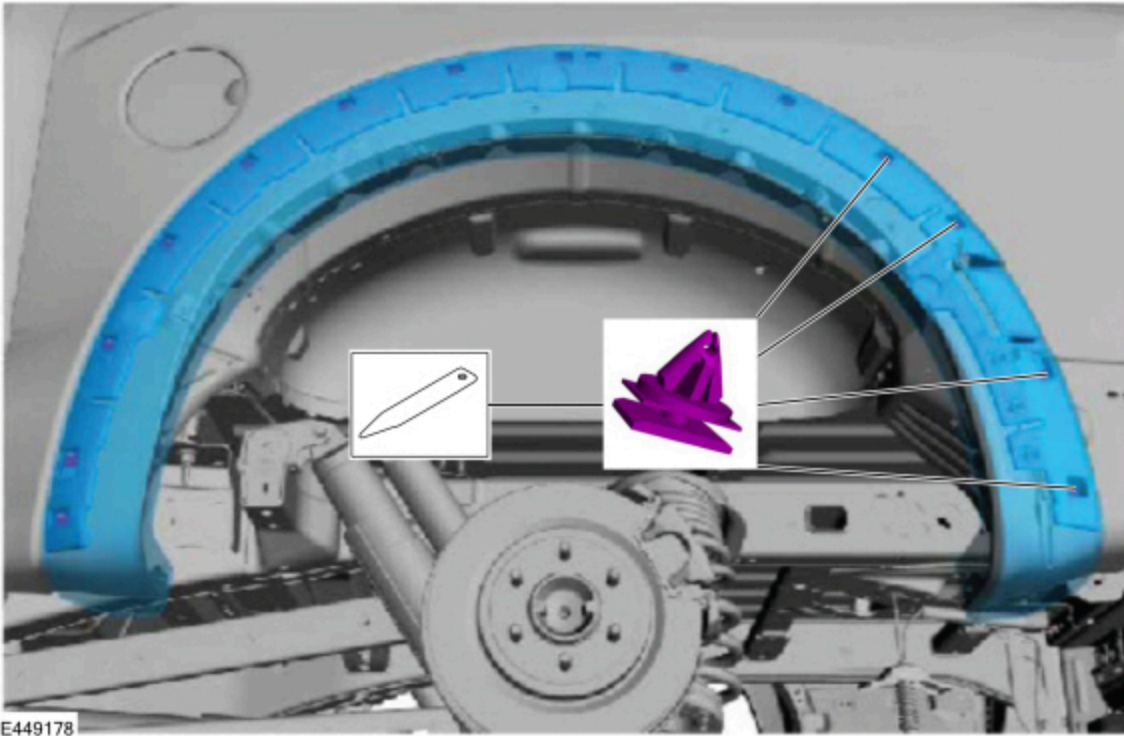
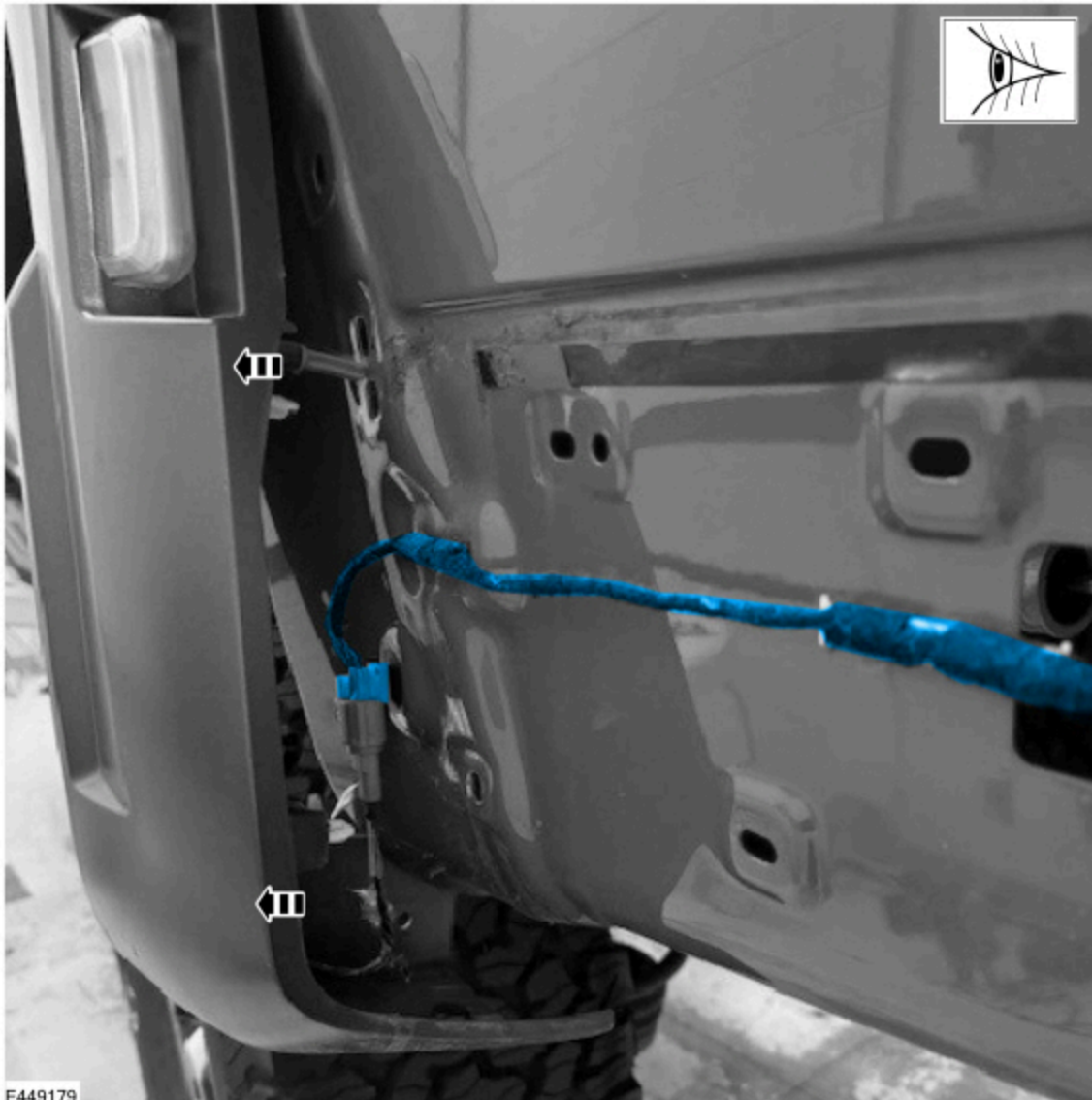

Figure 4



E449178

Figure 5



7. Inspect connector C4628 for the presence of corrosion, dirt and/or damage. Is corrosion, dirt and/or damage present in connector C4628? (Figure 2)

(1). Yes - replace the pickup bed AC power outlet socket assembly. Refer to WSM, Section 414-05. Replace the body side harness assembly (13A409) of connector C4628. Proceed to Step 8.

(2). No - proceed to Step 8.

8. Install a new pickup bed AC power outlet socket harness retainer 4.3 in. (110 mm) from the back of the pickup bed power outlet harness connector. If the pickup bed AC power outlet socket has been replaced, remove and discard the factory-installed harness retainer and install the new harness retainer. (Figure 6)

Figure 6

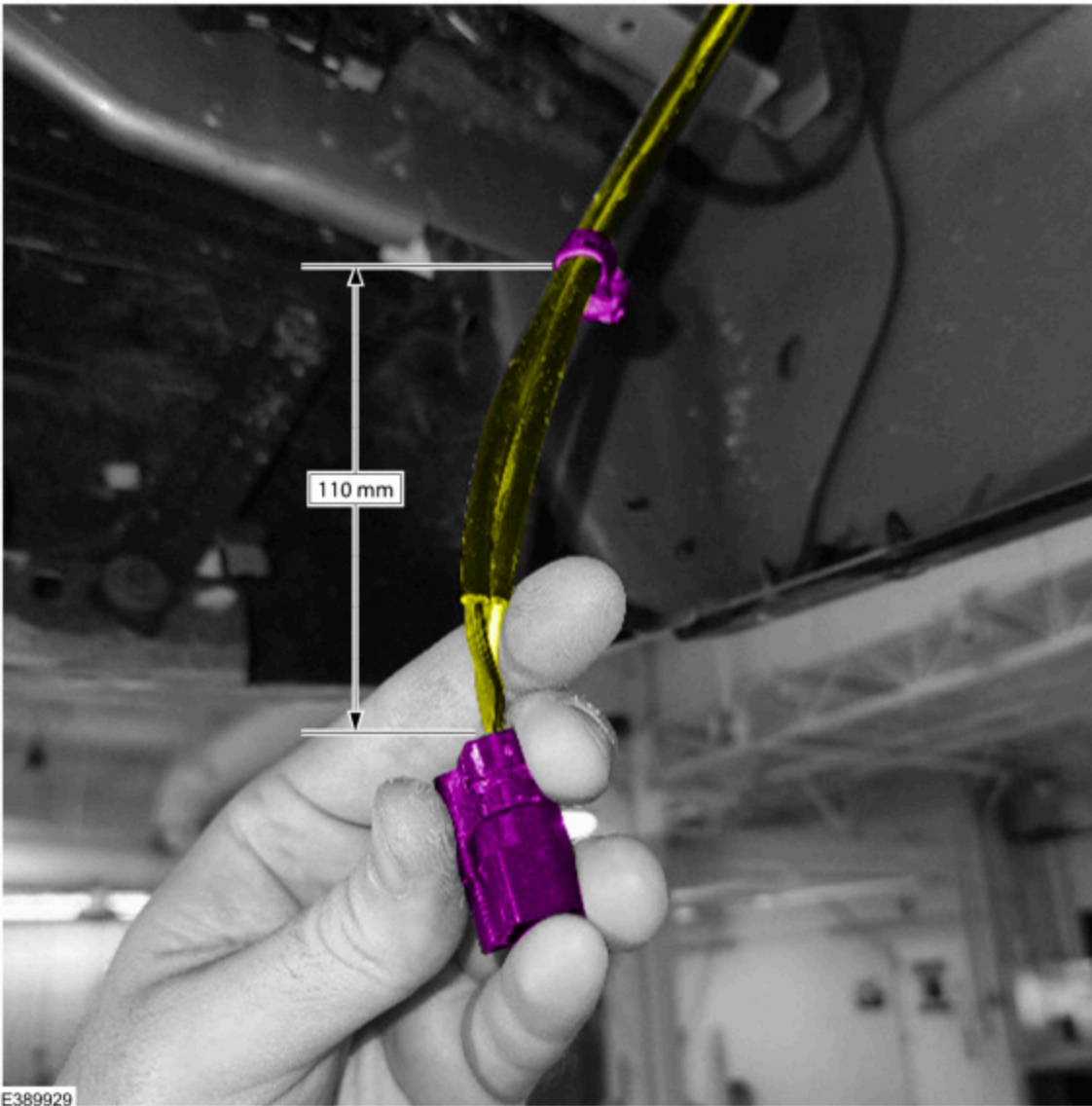

9. Apply Motorcraft® Electrical Grease to the pickup bed AC power outlet socket connector and reconnect to the C4628 bodyside harness. Secure the harness retainer to the body. (Figure 7)

Figure 7

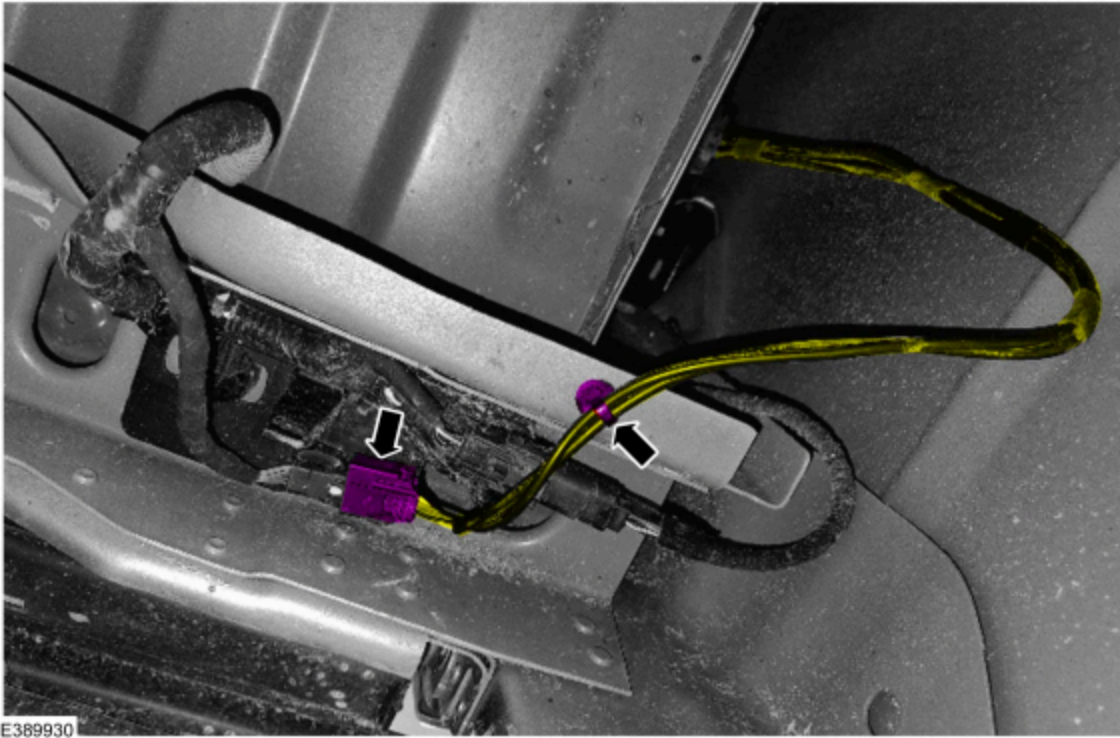

**⚠ CAUTION: The bend radius of the pickup bed AC power outlet socket harness should be no less than 4 mm. Hard kinks and tight bends of the pickup bed AC power outlet socket harness can lead to wire damage.**

**10.** Fold approximately 7 in. (185 mm) of the remaining/loose pickup bed AC power outlet socket harness in 2 bends just behind the pickup bed AC power outlet socket panel. Secure the folded wire with a wire tie. Inspect the routing of the harness to make sure it is not pulled too tight against the body sheet metal near the harness retainer and provides just enough length. (Figure 8)

Figure 8



11. Tightly compress the bends and completely wrap the folded pickup bed AC power outlet socket harness section with anti-abrasion electrical tape. (Figure 9)

Figure 9



12. Download and run the "BCM - Reset the Battery Monitoring Sensor Learned Values" application and then the "BCM - Local Interconnect Network (LIN) New Module Initialization" in the FDRS to relearn the DCACA outlet configuration and retest. If DTC B1330:9A persists, continue with normal diagnostics in the WSM, Section 414-05.

© 2024 Ford Motor Company

All rights reserved.

NOTE: The information in Technical Service Bulletins is intended for use by trained, professional technicians with the knowledge, tools, and equipment to do the job properly and safely. It informs these technicians of conditions that may occur on some vehicles, or provides information that could assist in proper vehicle service. The procedures should not be performed by "do-it-yourselfers". Do not assume that a condition described affects your car or truck. Contact a Ford or Lincoln dealership to determine whether the Bulletin applies to your vehicle. Warranty Policy and Extended Service Plan documentation determine Warranty and/or Extended Service Plan coverage unless stated otherwise in the TSB article. The information in this Technical Service Bulletin (TSB) was current at the time of printing. Ford Motor Company reserves the right to supersede this information with updates. The most recent information is available through Ford Motor Company's on-line technical resources.