

Diagnostic Sheet

FROM: Maserati TSO

TO: Maserati Network



Maserati

PERSONAL SERVICE LAB

MASTERS OF CARE

BSG Belt Diagnosis

DATE: December 5, 2024

This document aims to provide diagnostic information regarding problems of abnormal noise or breakage of the BSG (Belt Starter Generator) belt. **This diagnostic sheet requires a BOL under "Support Request" to be opened.**

MODELS: M182 Grecale (L4 engines only) – All MYs

SUBJECT: Diagnosis of abnormal noise or breakage of the BSG belt

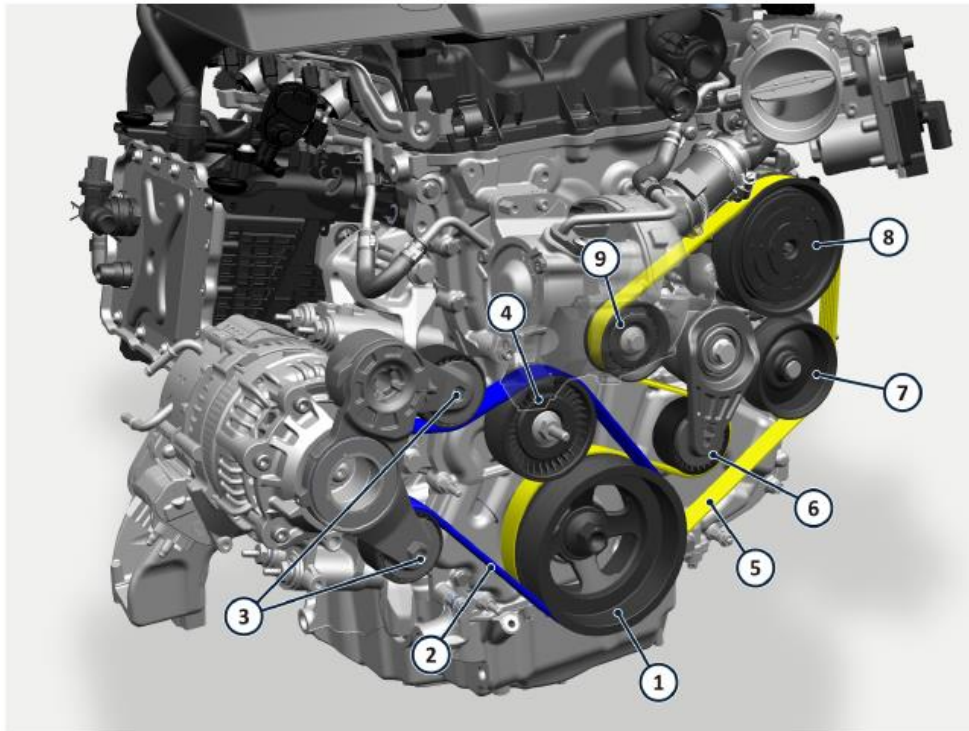

- | | |
|-------------------------|-------------------------------|
| 1. Crankshaft pulley | 6. Accessory belt tensioner |
| 2. BSG belt | 7. Coolant pump pulley |
| 3. BSG belt tensioner | 8. A/C compressor pulley |
| 4. BSG belt idle pulley | 9. Accessory belt idle pulley |
| 5. Accessory belt | |

CHECKLIST:

- 1) Collect the following information from the customer:
 - a. Driving conditions at the first occurrence of the complaint (e.g. during acceleration, idling, etc.)
 - b. Did the problem appear when the engine was cold/hot?
 - c. Environmental conditions (e.g. external temperature, climate conditions, etc.)
 - d. Location of vehicle usage (e.g. 100% urban, mixed, mostly highway, etc.)
- 2) Provide a complete PDF scan report of all ECUs.
- 3) Provide photographic documentation of the components before carrying out any rework (front and top views).
- 4) If the BSG belt is noisy, please provide a short video that clearly shows the problem under the following conditions:
 - a. with cold engine
 - b. with warm engine
 - c. during engine acceleration, with the gearbox in P
 - d. at idle, with the gearbox in P
- 5) In case of breakage, even partial, recover and keep any pieces of the belt.
- 6) Remove the BSG protective cover and provide additional photographic documentation.
- 7) If possible, measure the belt tension **with the engine cold** (by using a Clavis Tension Meter, or equivalent). Carry out three measurements at the point indicated by the red arrow in the image below and report the frequency values found (in Hz).

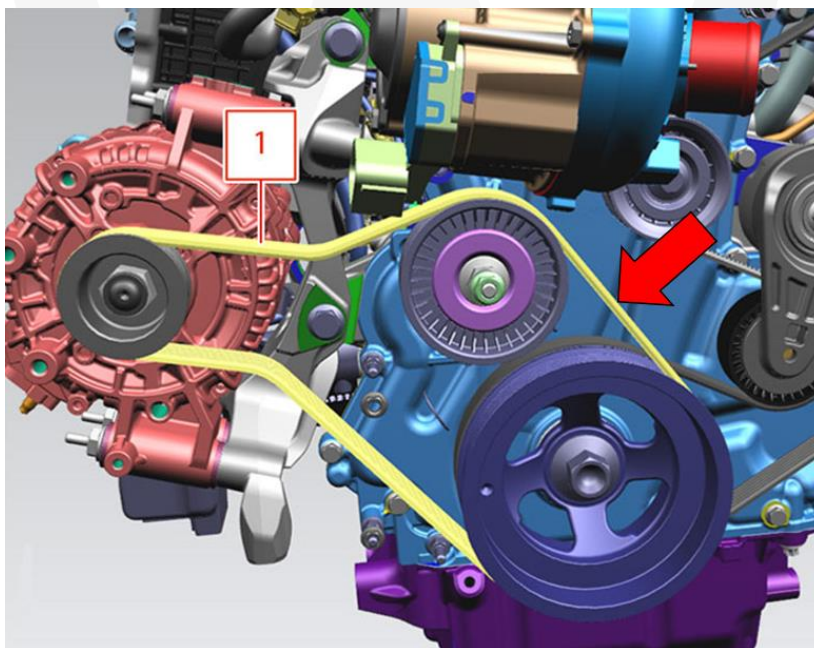

- 8) Manually check the movement of the BSG belt tensioner (component n.3 on page one). Is there any abnormal movement? Is the BSG support moving? Record a short video during the check.
- 9) Manually check the rotation of the BSG idler pulley (component n.4 on page one). Record a short video during the check.
- 10) Using a torque wrench, check the tightening of the BSG fixing screws, referring to the nominal torques reported in the workshop manual. Report any anomalies.
- 11) Manually check that there is no relative movement between the BSG and its fixing bracket (component number "5", in the figure below), and between the bracket and the crankcase. If abnormal movements are found, document the problem with a video.

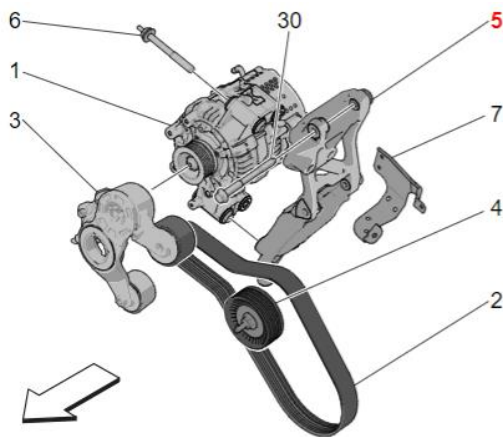

- 12) Open a BOL as a "Factory Information", reporting all the information collected during the diagnosis and related attachments. The compromised elements (BSG, belt, belt tensioner, and idler pulley) will be requested back for further analysis.

NOTE: If the BSG pulley is not damaged, it is not necessary to replace the BSG.

- 13) In case of damage or breakage of the BSG belt on L4 engines with serial number lower than 1969300, during the replacement of the damaged components it is required to loosen the fixing nut of the idle pulley and tighten it to 70 Nm.

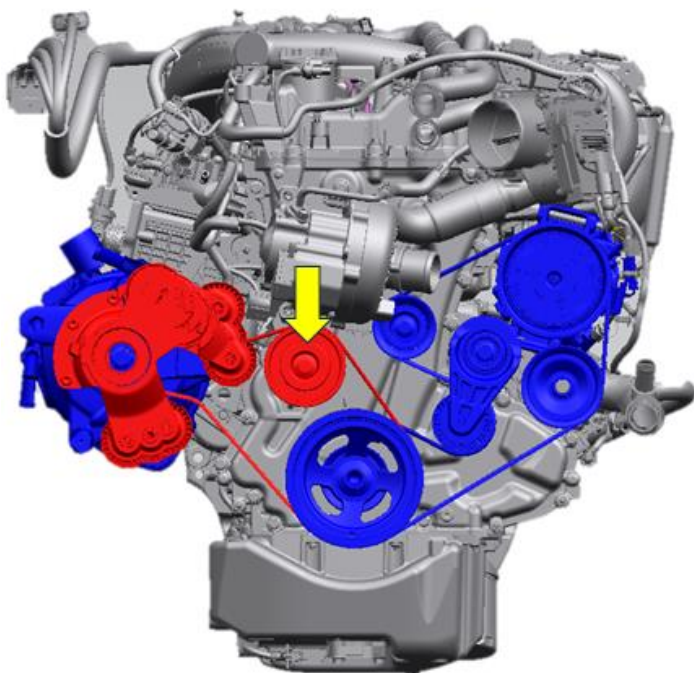

NOTE: Please note that this tightening torque value (higher than what is specified in the workshop procedure) must be applied exclusively to vehicles subject to abnormal wear, fraying or breakage of the BSG belt.

TECHNICAL SERVICE OPERATIONS