



Service Bulletin

Bulletin No.: 18-NA-210

Date: November, 2024

TECHNICAL

Subject: High Pitch Whine Noise Coming from Front Instrument Panel (IP) Speakers

Brand:	Model:	Model Year:		VIN:		Engine:	Transmission:
		from	to	from	to		
Chevrolet	Equinox	2018	2024	—	—	—	—
GMC	Terrain						

Involved Region or Country	North America, Middle East, Israel, Palestine, Argentina, Brazil, Chile, Colombia, Ecuador, Paraguay, Peru, Uruguay, GM Korea Company, Thailand, Egypt, Other Africa
Additional Options (RPOs)	Active Noise Cancellation (NKC), 6 Speaker System (UZ6)
Condition	Some customers may comment that a high pitch whine noise can be heard coming from the IP speakers. Some customers may also comment that a high pitch noise can be heard coming from the IP speakers when the vehicle is turned off.
Cause	This condition may be caused by electromagnetic interference from the TCM circuit (2173: 12V Regulated Supply Voltage 2), in close proximity of the speaker circuits while the module is receiving power. ⇒ Noise goes away when the TCM has been put in sleep mode or the fuse has been removed.
Correction	Remove the TCM fuse from the fuse block and validate if the frequency noise was eliminated. <ul style="list-style-type: none">• If the frequency has been eliminated, refer to the Service Procedure section for separating the 2173 circuit (12V Regulated Supply Voltage 2), TCM B+ from the main wiring harness.• If the frequency has not been eliminated, refer to SI for further diagnostics.

Important: Service agents must comply with all International, Federal, State, Provincial, and/or Local laws applicable to the activities it performs under this bulletin, including but not limited to handling, deploying, preparing, classifying, packaging, marking, labeling, and shipping dangerous goods. In the event of a conflict between the procedures set forth in this bulletin and the laws that apply to your dealership, you must follow those applicable laws.

Service Procedure

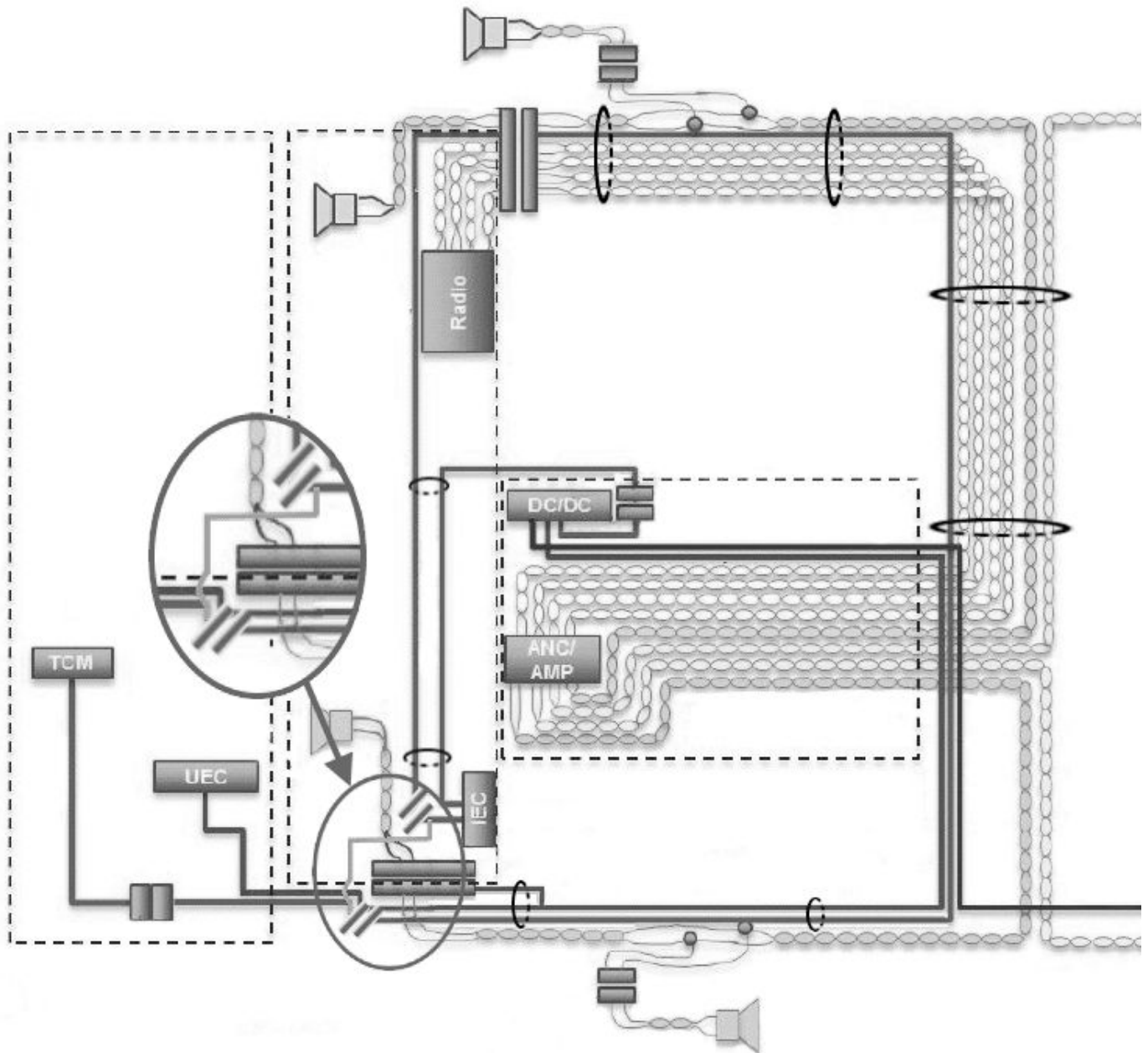

5112945

Important: Performing this repair will eliminate the 2173 circuit wire from the IP wiring harness and bypass it directly to the body side harness, as shown in green in the schematic above.

1. Remove the instrument panel (IP) fuse block from the fuse block mount.
2. Remove the TCM 20-amp fuse and set aside. Refer to the Instrument Panel (IP) fuse block cover in SI for fuse location.
3. Remove the fuse block protective cover.

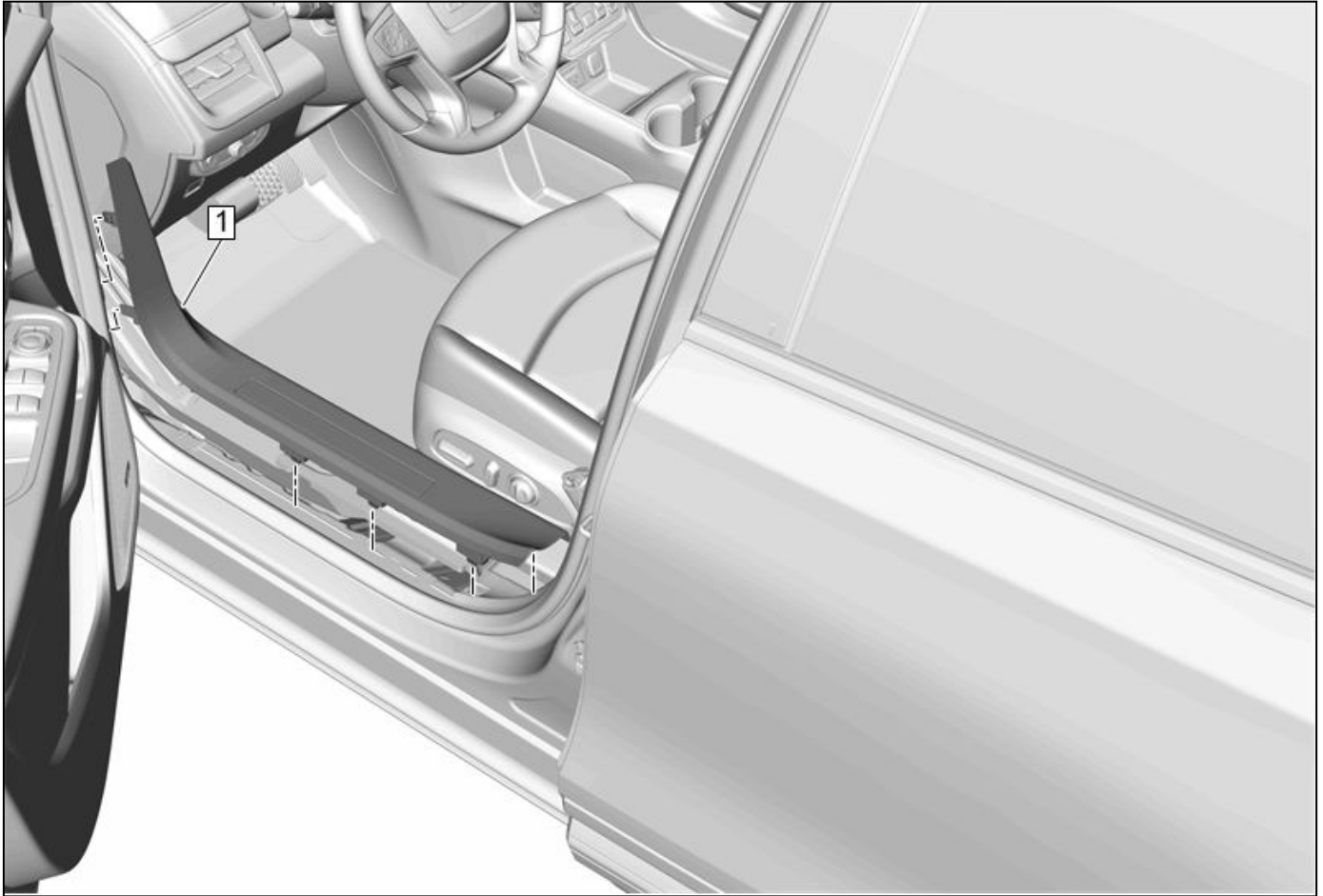

4743979

4. Remove the drivers side sill garnish molding (1).



5. Position the carpet aside.
6. Remove the footrest absorber.

5111718



5111727

7. Remove the tie straps that secure the body harness to the plastic shield.
8. Using care, cut the protective cover that is covering the body side wiring harness.
9. Separate all the Red/Green wires from the harness.



5153847

10. Utilizing a DVOM set to OHMs, locate the 2173 circuit by back probing the RD/GN wires starting from pin 36 (1) at the junction block down the body harness near the floor.
11. When the circuit has been identified, cut the RD/GN wire at the body harness near the floor.
12. Cut the other end of the harness roughly 76–102 mm (3 to 4 inches) from the junction block.
13. Determine the length of wire required from the body side harness to reach the junction block wire, cutting away at the harness cover as required.
14. When the length of wire has been determined, insert the wires into the blue colored Dura Seal™ splice sleeve and crimp and seal the splice sleeve.
15. Using Woven Polyester Electrical/Anti-Abrasive Tape (PET) or equivalent, with the 12V Regulated Supply Voltage 2 circuit separated from the IP harness bundle, tape the spliced sleeve.
16. Install the junction block protective cover.



5112022

17. Wrap the body wiring harness bundle with PET or equivalent, leaving the 12V Regulated Supply Voltage 2 circuit separated from the harness.
18. If removed, install TCM fuse.
19. Install the junction block.



5112024

20. Secure the body side harness to the plastic shield.
21. Install the footrest absorber.
22. Install the carpet.
23. Install the drivers side sill garnish molding.

Parts Information

No parts are required for this repair.

Warranty Information

For vehicles repaired under the Bumper-to-Bumper coverage (Canada Base Warranty coverage), use the following labor operation. Reference the Applicable Warranties section of Investigate Vehicle History (IVH) for coverage information.

Labor Operation	Description	Labor Time
5480548*	Instrument Panel 12V Regulated Supply Voltage 2 Wire Routing	1.2 hrs
*This is a unique Labor Operation for bulletin use only.		

Version	4
Modified	Released June 21, 2018 Revised October 16, 2018 – Added additional information to the Service Procedure. Revised July 29, 2020 – Added the 2020 Model Year, updated the Involved Region or Country section and corrected an RPO in the Additional Options (RPOs) section. Revised November 14, 2024 – Added Model Years 2021-2024.

