

## Volvo Car USA LLC

## Technical Journal

Technical Journal Title Vehicle unresponsive		Ref. No. TJ 37145.1.0	
Issuer (Dept.) Technical Service		Issue Date 11/13/24	Status Date 11/26/24
Car Market United States and Canada	Partner 3 US 7510 Volvo Car USA	Function Group 8344	
Function Description Handle, outer for side door		Page Page 1 of 3	

### Attachment

File Name	File Size
TJ_37145_1.JPG	0.0647 MB

### DESCRIPTION:

If the vehicle is unresponsive (doesn't wake up at approach or will not unlock by pressing handle sensor), please follow advice under "Service".

### CSC Customer Symptom Codes

Code	Description
VZ	Locking/unlocking/Other central locking problems

### DTC Diagnostic Trouble Codes

### Vehicle Type

Type	Eng	Eng Desc	Sales	Body	Gear	Steer	Model Year	Plant	Chassis range	Struc Week Range
356							2025-9999		-	202417-999952

### SERVICE:

Do not perform a 12V reset until you have followed the steps in correct order.

- Place the NFC (Near Field Communication) key card on the driver's side door handle and hold for 5 seconds.  
Repeat this process at least three times, allowing a 10-second interval between each attempt.
- If step 1 does not work, try unlocking the car through the Volvo app on the cell phone.
- If step 2 does not work, measure the 12V battery. This is to be done by accessing the external point under the front bumper (See attachment TJ\_37145\_1.JPG). Not on the battery.  
If it's below 8V, cancel the steps and charge the battery according to VIDA. First perform the Emergency Opening steps in VIDA to get access to the vehicle: *Information > General Information > 3 Electrical System > 300 General > Emergency Opening*  
*For charging the battery follow these steps in VIDA: Information > Cleaning, Inspection & Adjustment > 311 Battery > Battery, charging*  
If it's 12V, proceed to the next step.

## Technical Journal 37145.1.0

---

4. If step 3 does not work, try the following steps:
  - a) Pressing the release cable button next to the charging port of the car
  - b) Place the NFC key card on the driver side door handle according to step 1 again
5. If step 4 does not work, try the following steps:
  - a) Press the button for the tailgate. (Note: do not expect the tailgate to open)
  - b) Place the NFC key card on the driver side door handle according to step 1.
  - c) Repeat step 5 at least 3 times
6. If none of the steps above solves the issue, check diagnostics if any nodes are not responding (especially LPC, DDM, NFCA). If you can get into the car by any means, then perform a 12V power reset.

*(In VIDA: Planning & Diagnostics > Diagnostics > Network)*

In Vehicle Reports, please specify which steps above helped to recover the functionality. If step 6, specify which ECU was not responding.

ECU: Electronic Control Unit  
LPC: Low Power Controller  
DDM: Driver Door Module  
NFCA: Near Field Communication A

### Warranty claim info:

To get a warranty claim accepted for a job described in this TJ, use the corresponding VST OP number stated in this TJ.

Note that the TJ number must be stated in the repair order text.

### VST Operation Number

VST Operation Number	Description
99921-2	General reimbursement acc. to TJ

### VEHICLE REPORT:

Yes, please submit a Vehicle Report if the service solution described in this TJ has no effect. Use concern area "Vehicle Report" and sub concern area "Support needed", use function group 8344.

**To view TJ attachment continue to next page. This TJ has one attachment.**

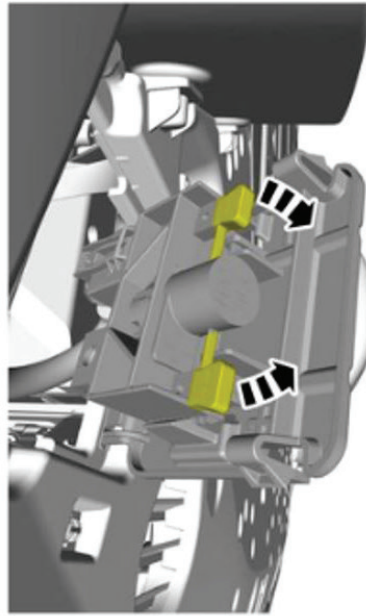
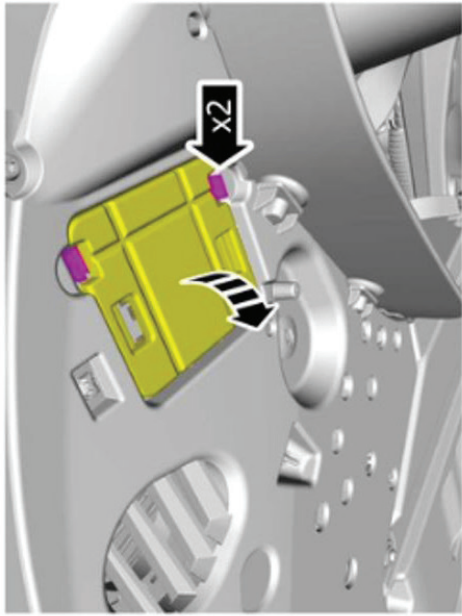

TJ 37145