

Complaint - Check Engine Error Message in Conjunction with Loss of Power or a Creaking Noise after Switching off the Engine (222/20)

Change overview:

Release	Date	Change
0	03/09/2021	<ul style="list-style-type: none"> First publication
1	11/19/2024	<ul style="list-style-type: none"> Part-ID changed from 2190 to 2193 Component designation changed from pressure converter to boost pressure control cycle valve

Model Line: **Cayman (982)/Cayman S (982)/Cayman GTS (982)/Cayman T (982)**

Model Year: **As of 2017 up to 2021**

Equipment: 4-cylinder engines

Concerns: **Boost pressure control cycle valve**

Information: **Customers complain about:**

- The Check Engine warning light coming on in conjunction with loss of power
- A creaking noise after switching off the engine and when driving at low revs

One or more of the following fault memory entries are also stored in the engine electronics (DME) control unit:

- P0234 - Boost pressure control limit exceeded
- P0299 - Boost pressure control deviation
- P2262 - Boost pressure too low for tank ventilation

Date of Introduction: A Boost pressure control cycle valve with an external air cleaner has been installed during production since December 10, 2020.

Action required: Remove old Boost pressure control cycle valve and install new Boost pressure control cycle valve with external air cleaner.

Installation

Position:

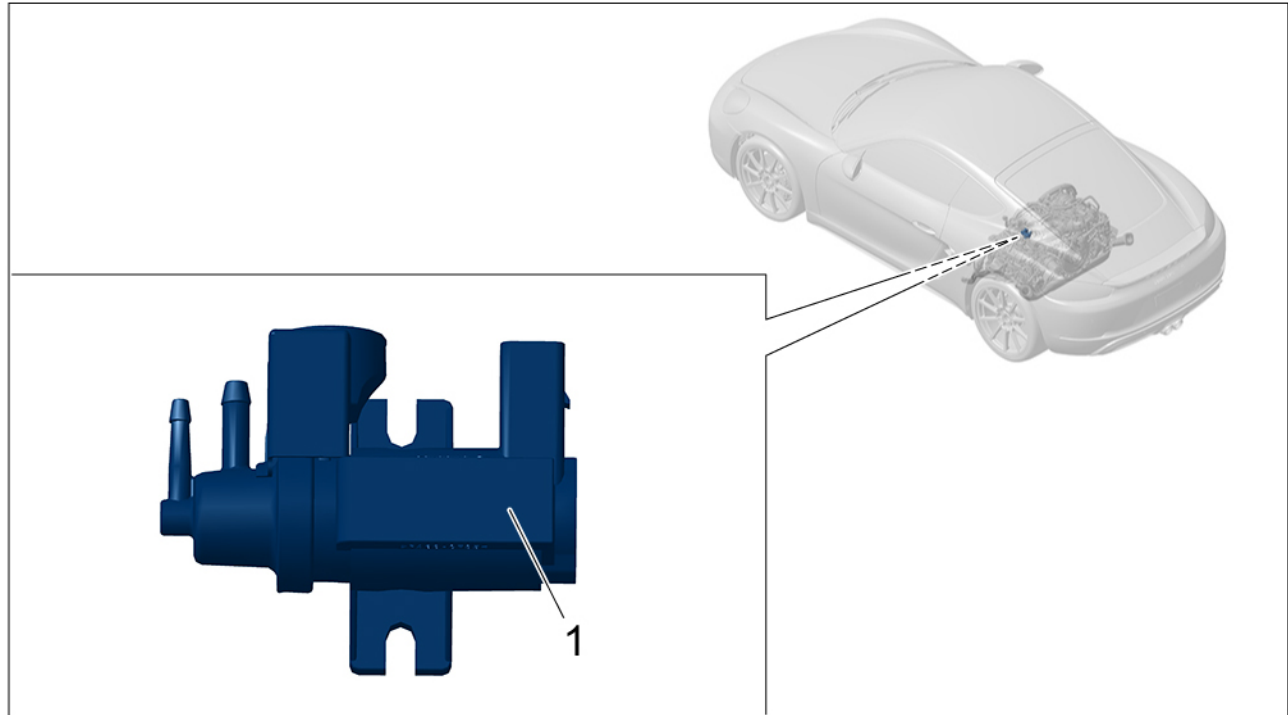

Installation position of Boost pressure control cycle valve

1 – Boost pressure control cycle valve (old)

Required tools

Tools: • V.A.G 1331A - Torque wrench, 6-50 Nm/4.5-37 ftlb.

Parts required

Parts Info:	Part No.	Designation – Location	Qty.
	9A790662700	⇒ Boost pressure control cycle valve – Turbocharger	1 ea.
	9A211008420	⇒ Air cleaner (complete) Includes: – Hose – Combination holder	1 ea.

Preparatory work

- Work Procedure: 1 Remove engine compartment lid, see ⇒ *Workshop Manual '557819 Removing and installing engine compartment lid'*.
- 2 To remove air filter housing, see ⇒ *Workshop Manual '242519 Removing and installing air filter housing'*.

Replacing Boost pressure control cycle valve

- Work Procedure: 1 Remove old Boost pressure control cycle valve.
- 1.1 Disconnect vacuum hoses ⇒ *Boost pressure control cycle valve -2-* and ⇒ *Boost pressure control cycle valve -3-* from the Boost pressure control cycle valve ⇒ *Boost pressure control cycle valve -1-* one after the other.
- 1.2 Release and disconnect electric plug connection ⇒ *Boost pressure control cycle valve -4-* on the Boost pressure control cycle valve ⇒ *Boost pressure control cycle valve -1-*.
- 1.3 Unscrew fastening screws ⇒ *Boost pressure control cycle valve -5-* on the Boost pressure control cycle valve ⇒ *Boost pressure control cycle valve -1-* and remove Boost pressure control cycle valve.

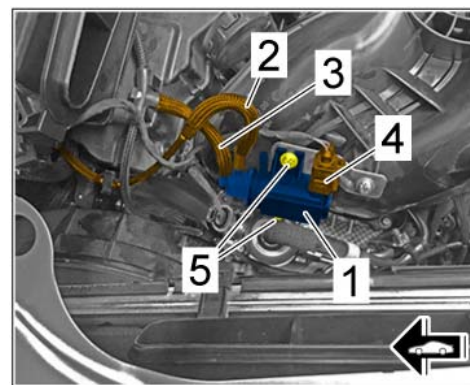

Boost pressure control cycle valve

- 2 Prepare new Boost pressure control cycle valve for installing.
- To do this, install air cleaner ⇒ *Boost pressure control cycle valve (new) -2-* as shown ⇒ *Boost pressure control cycle valve (new)* on the Boost pressure control cycle valve ⇒ *Boost pressure control cycle valve (new) -1-*.

Item	Part No.	Designation
1	9A790662700	Boost pressure control cycle valve
2	9A211008420	Air cleaner (complete) Includes: – Hose – Combination holder

**Information**

Use water as a lubricant to make installing easier if necessary.

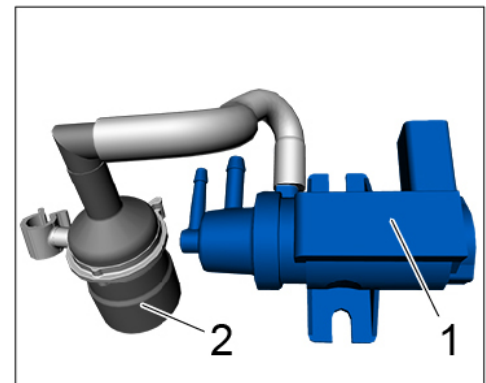

Boost pressure control cycle valve (new)

- 3 Install new Boost pressure control cycle valve with external air cleaner.
 - 3.1 Position new Boost pressure control cycle valve ⇒ *Boost pressure control cycle valve for turbocharger (new)-1-* and install and tighten fastening screws ⇒ *Boost pressure control cycle valve for turbocharger (new)-5-*.
Tightening torque 13 Nm (9.5 ftlb.)
 - 3.2 Position and connect vacuum hoses ⇒ *Boost pressure control cycle valve for turbocharger (new)-2-* and ⇒ *Boost pressure control cycle valve for turbocharger (new)-3-* on the Boost pressure control cycle valve ⇒ *Boost pressure control cycle valve for turbocharger (new)-1-* one after the other.

**Information**

Use water as a lubricant to make installing easier if necessary.

- 3.3 Connect and lock electric plug connection ⇒ *Boost pressure control cycle valve for turbocharger (new)-4-*.

- 3.4 Clip in combination holder ⇒ *Boost pressure control cycle valve for turbocharger (new)* -6- on the vacuum hose ⇒ *Boost pressure control cycle valve for turbocharger (new)* -2- underneath the anti-chafing tape.

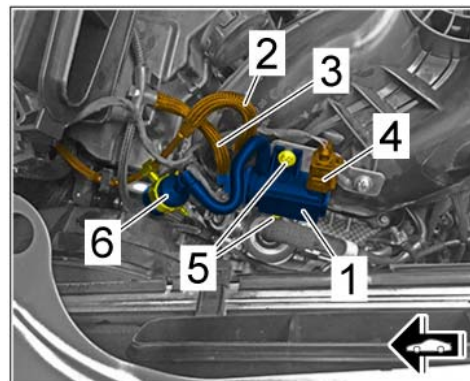

Boost pressure control cycle valve for turbocharger (new)



Information

Once installed, check the routing and position of the vacuum hoses with regard to the following points and re-position them if necessary.

- Sufficient distance from heat shields/fan housing/electric plug connection for high-pressure pump
- Vacuum hoses are not strained

Concluding work

- Work Procedure: 1 To install air filter housing, see ⇒ *Workshop Manual '242519 Removing and installing air filter housing'*.
- 2 Install engine compartment lid, see ⇒ *Workshop Manual '557819 Removing and installing engine compartment lid'*.

Invoicing

Invoicing: For documentation and warranty invoicing, enter the labor operations, PQIS coding and part numbers specified below in the warranty claim:

APOS	Labor operation	I No.
21934900	Reworking boost pressure control cycle valve	

PCSS encryption:

Location (FES5)	21930	Cycle valve
Damage type (SA4)	2022	whining, whistling

Parts Info:	Part No.	Designation	Qty.
	9A790662700	Boost pressure control cycle valve	1 ea.
	9A211008420	Air cleaner (complete)	1 ea.

References: ⇒ *Workshop Manual '242519 Removing and installing air cleaner housing'*
⇒ *Workshop Manual '557819 Removing and installing engine compartment lid'*

Important Notice: Technical Bulletins issued by Porsche Cars North America, Inc. are intended only for use by professional automotive technicians who have attended Porsche service training courses. They are written to inform those technicians of conditions that may occur on some Porsche vehicles, or to provide information that could assist in the proper servicing of a vehicle. Porsche special tools may be necessary in order to perform certain operations identified in these bulletins. Use of tools and procedures other than those Porsche recommends in these bulletins may be detrimental to the safe operation of your vehicle, and may endanger the people working on it. Properly trained Porsche technicians have the equipment, tools, safety instructions, and know-how to do the job properly and safely. Part numbers listed in these bulletins are for reference only. The work procedures updated electronically in the Porsche PIWIS diagnostic and testing device take precedence and, in the event of a discrepancy, the work procedures in the PIWIS Tester are the ones that must be followed.

© 2024 Porsche Cars North America, Inc.