

JLRTB02127NAS2

# TECHNICAL BULLETIN

01 JAN 2001



© Jaguar Land Rover North America, LLC

NOTE: The information in Technical Bulletins is intended for use by trained, professional Technicians with the knowledge, tools, and equipment required to do the job properly and safely. It informs these Technicians of conditions that may occur on some vehicles, or provides information that could assist in proper vehicle service. The procedures should not be performed by 'do-it-yourselfers'. If you are not a Retailer, do not assume that a condition described affects your vehicle. Contact an authorized Land Rover service facility to determine whether this bulletin applies to a specific vehicle.

## INFORMATION

This bulletin supersedes TSB JLRTB02127NAS1/2024 dated 27 NOV 2024, which should either be destroyed or clearly marked to show it is no longer valid (e.g. with a line across the page). Only refer to the electronic version of this Technical Bulletin in TOPIx.

## SECTION:

303-03A

## SUBJECT /CONCERN:

Engine Coolant Level Low Message Displayed on Instrument Panel

## AFFECTED VEHICLE RANGE:

MODEL:	MODEL YEAR:	VIN:	ASSEMBLY PLANT:
Range Rover (LK)	2022-2024	000001-234058	Solihull
Range Rover Sport (L1)	2023-2024	000001-400762	Solihull

## MARKETS:

NORTH AMERICA

## CONDITION SUMMARY:

### SITUATION:

A customer may express a concern that there is a 'Coolant Level Low' message displayed on the instrument panel cluster, or that the coolant level requires frequently topping up, or that the 'Coolant Level Low' message is displayed when the coolant level is at minimum or above.

### CAUSE:

Permeation of water content from the engine coolant through plastic pipes.

### ACTION:

Follow the Service Instruction below.



#### The following applies to:

All Vehicles

## PARTS:

### NOTES:

- \*When stock of 104123458 is depleted order 104123663.
- \*\*An allowance equivalent to £5.00 Sterling has been allocated to locally source engine coolant.

PART NUMBER	DESCRIPTION	QUANTITY
*104123458 or 104123633	Coolant Expansion Tank	1
**ZZZ001	Engine Coolant	£5



### The following applies to:

INGENIUM I6 3.0L Petrol / INGENIUM I6 3.0L Petrol PHEV Vehicles Only

### PARTS:

### NOTES:

- \*When stock of 202123501 is depleted order 202123527.
- \*\*The 4 undershield fixing retainers (LR165498) are required for the Plug-in Hybrid Electric Vehicle (PHEV) vehicles **only**.

PART NUMBER	DESCRIPTION	QUANTITY
*202123501 or 202123527	Fuel Supply Line	1
202123508	Fuel Supply Line to Expansion Tank Clip	1
LR185830	Fuel Supply Line to Vapour Damper Bracket Clip	1
**LR165498	Undershield Fixing Retainer	4

### SPECIAL TOOL(S)

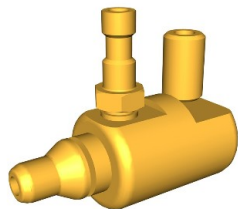

E303954

### JLR-303-1720-01

Adaptor - Coolant  
Expansion Tank  
Pressure Test

**GENERAL EQUIPMENT****EQUIPMENT NAME**

Cooling system pressure tester

**WARRANTY:****NOTES:**

- Repair procedures are under constant review, and therefore times are subject to change; those quoted here must be taken as guidance only. Use TOPIx to obtain the latest repair time.
- The JLR claims submission system requires the use of causal part numbers. Labor only claims must show the causal part number with a quantity of zero.

DESCRIPTION	SRO	TIME (HOURS)	CONDITION CODE	CAUSAL PART
Cooling System Inspection	05.10.10	0.1	*	LR151660
Cooling System Pressure Test	26.10.07	0.2	*	LR151660
Coolant Expansion Tank	26.15.01	0.5	*	LR151660
Fuel Supply Line - Range Rover - INGENIUM I6 3L Petrol	19.43.42	2.9	*	LR178362
Fuel Supply Line - Range Rover Sport - INGENIUM I6 3L Petrol	19.43.42	3.0	*	LR178362
Fuel Supply Line - Range Rover - INGENIUM I6 3L Petrol - PHEV	19.43.42	3.2	*	LR178362
Fuel Supply Line - Range Rover Sport - INGENIUM I6 3L Petrol - PHEV	19.43.42	3.2	*	LR178362
Cooling System Concentration Check	26.10.24	0.1	*	LR151660

 **NOTE:**

Normal Warranty procedures apply.

**INSPECTION**

 **WARNING:**

Injury such as scalding could be caused by escaping steam or coolant. The vehicle cooling system must be cool prior to completing this inspection.

 **CAUTIONS:**

- Engine coolant can damage the paint finished surfaces. If spilt, immediately remove the fluid and clean the area with water.
- Never remove the coolant expansion tank filler cap under any circumstances while the engine is operating. Failure to follow this instruction may result in damage to the engine.

**1.** Open the hood and check engine coolant level.

- If the level is at minimum or above and the low coolant level message is displayed on the instrument cluster, the cause may be related to a concern with the coolant level sensor.
  - Follow the TOPIx cloud workflow 'Powertrain - Warnings - Warning Message - Coolant Low' and follow the test plan 'Coolant level low message displayed on the instrument cluster' to test the coolant level sensor and wiring, then continue to next step 2.
- If the coolant level is below minimum continue to next step 3.

2.

 **NOTES:**

- Any related repairs must be claimed as a separate warranty claim.
- If the coolant expansion tank is replaced as a result of this inspection it will not be necessary to complete step 2 of the SERVICE INSTRUCTION.

If the issue was related to a wiring or coolant level sensor concern, repair as necessary following TOPIx and continue to step 1 of the service instruction.

3.

 **NOTES:**

- Any related repairs must be claimed as a separate warranty claim.
- Replace any damaged or faulty components before completing this bulletin.

Visually check the cooling system for signs of engine coolant leaks and distorted hoses. Make sure all the cooling system components are correctly installed.

- If there **are** any visual signs of engine coolant leaks **do not** continue with this bulletin. Repair as necessary with reference to TOPIx.
- If there **are no** visual signs of engine coolant leaks complete the **COOLING SYSTEM PRESSURE TEST** section of this bulletin.

## COOLING SYSTEM PRESSURE TEST

 **WARNING:**

Injury such as scalding could be caused by escaping steam or coolant. The vehicle cooling system must be cool prior to completing this procedure.

### CAUTIONS:

- Engine coolant can damage the paint finished surfaces. If spilt, immediately remove the fluid and clean the area with water.
- Never remove the coolant expansion tank filler cap under any circumstances while the engine is operating. Failure to follow this instruction may result in damage to the engine.
- Mating faces must be are clean and free of foreign material.

### NOTES:

- This procedure contains some variation in the illustrations depending on the vehicle specification, but the essential information is always correct.
- This procedure contains illustrations showing certain components removed to provide extra clarity.

1.

 **NOTE:**

Be prepared to catch escaping coolant.

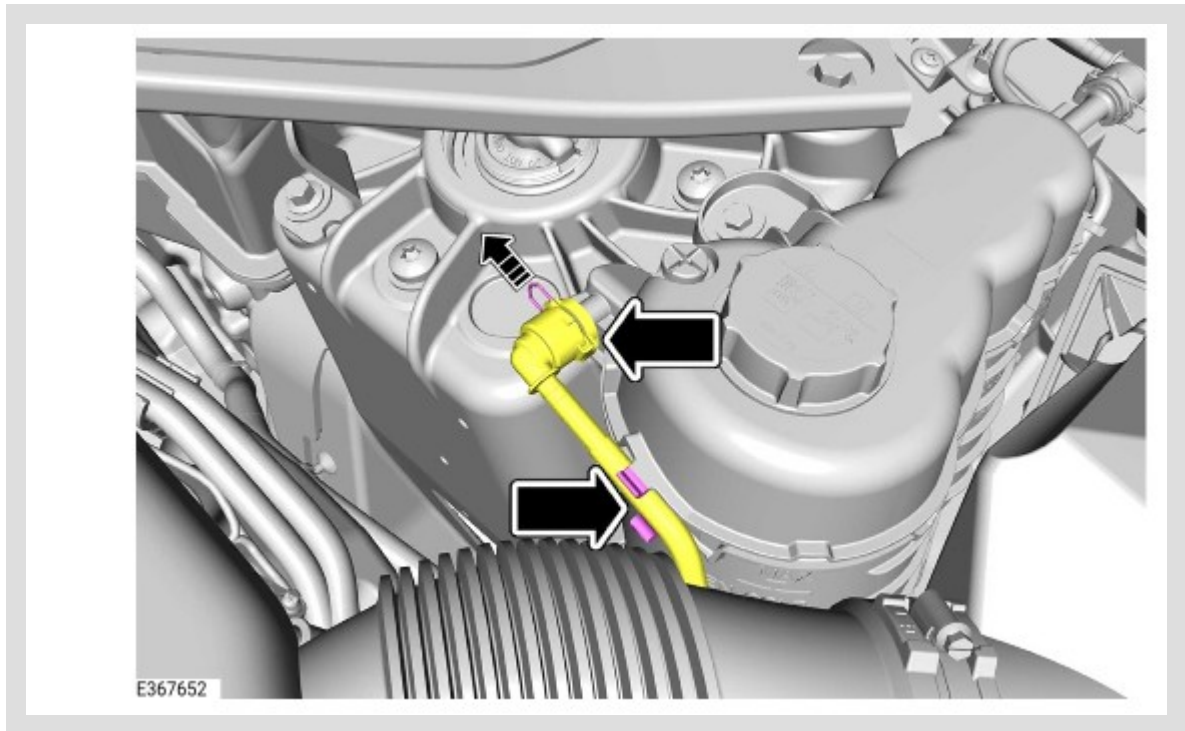

Disconnect and release the engine coolant vent pipe.

2.

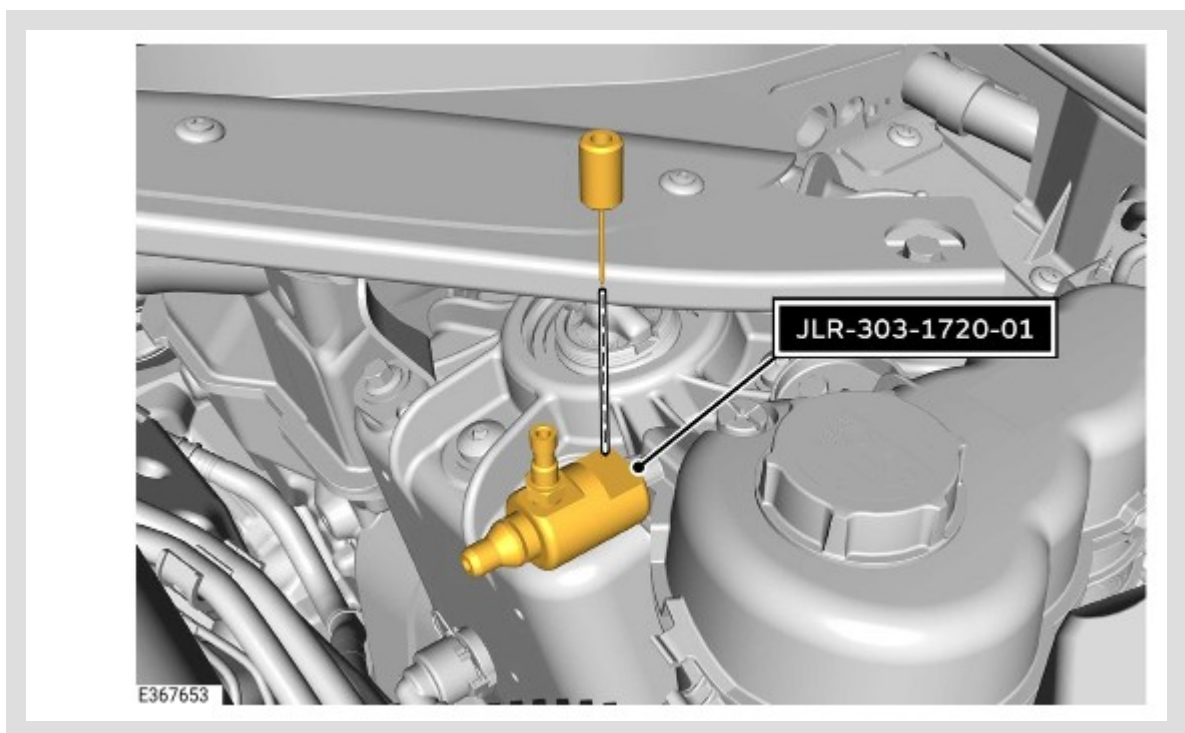

Install the special tool as illustrated.

*Special Tool(s):* [JLR-303-1720-01](#).

3.

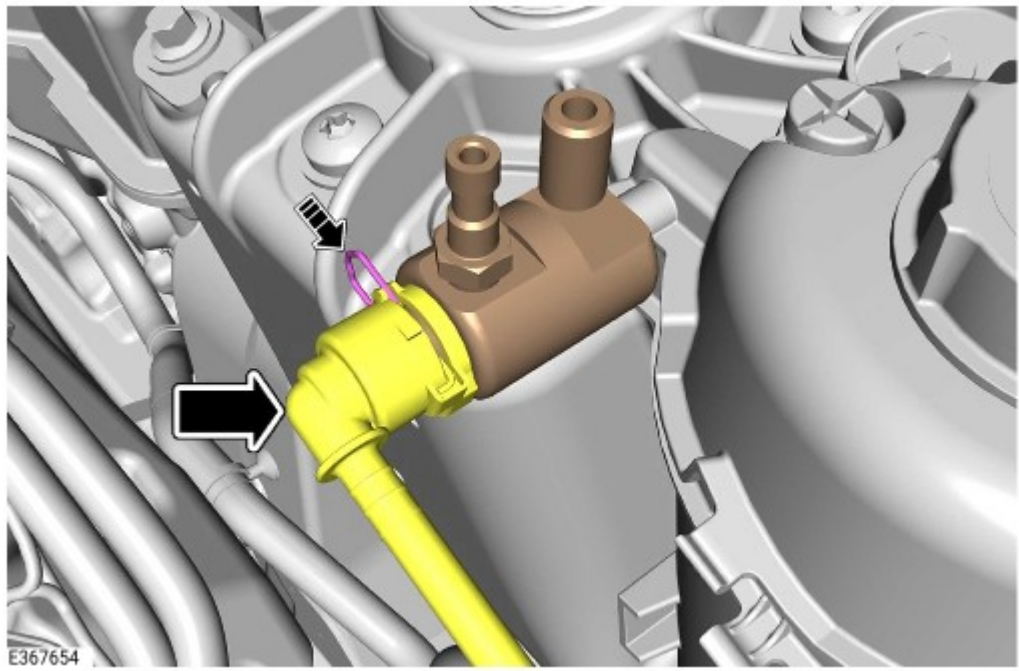

Connect the engine coolant vent pipe.

**⚠ CAUTION:**

Do not exceed 1.65 bar (24 psi - 165 kPa) when pressurizing the cooling system.

**⚠ NOTE:**

If the pressure continues to drop after the initial tolerance, the cooling system must be checked for leaks.

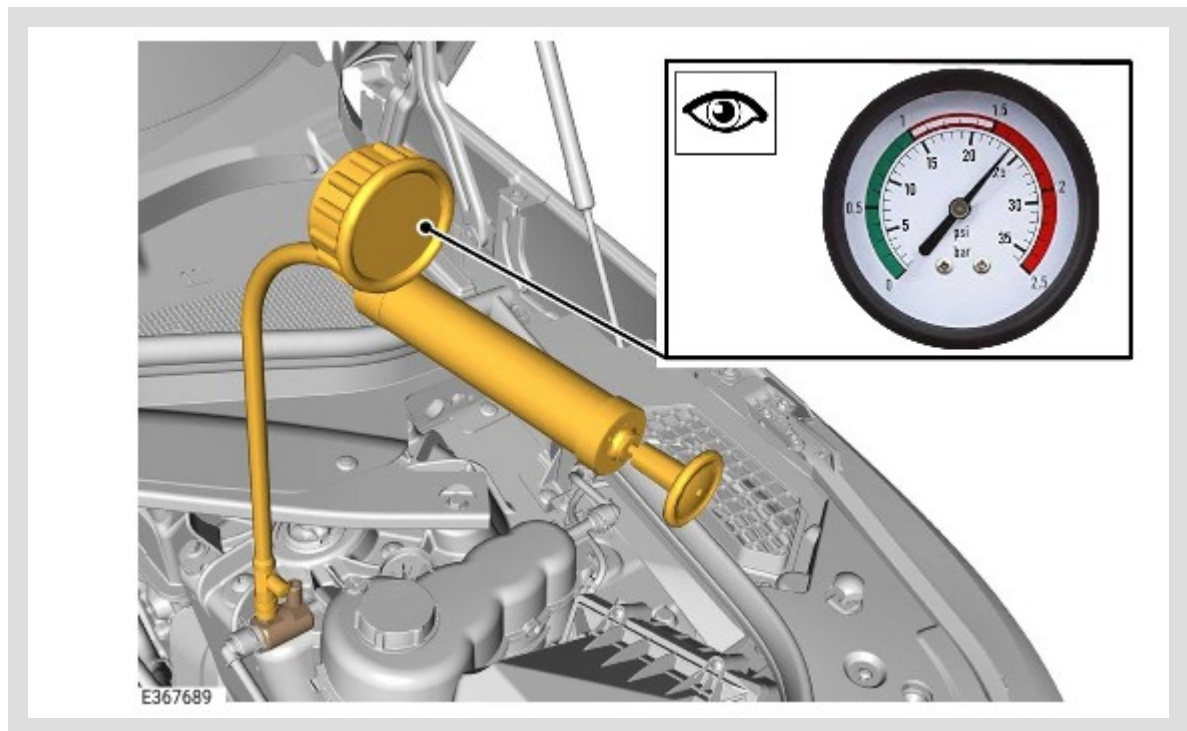

Connect the cooling system pressure tester to the cooling system pressure tester adapter.

- Slowly pressurize the cooling system until 1.65 bar (24 psi - 165 kPa) is shown on the gauge.
- No significant drop in pressure should be noted on the cooling pressure tester gauge. If after 5 minutes the pressure significantly drops, the cooling system must be inspected for leaks. A pressure drop of 0.07 bar (1psi - 100 kPa) in the first minute is considered normal operation.

*General Equipment:* [Cooling system pressure tester](#).

5.

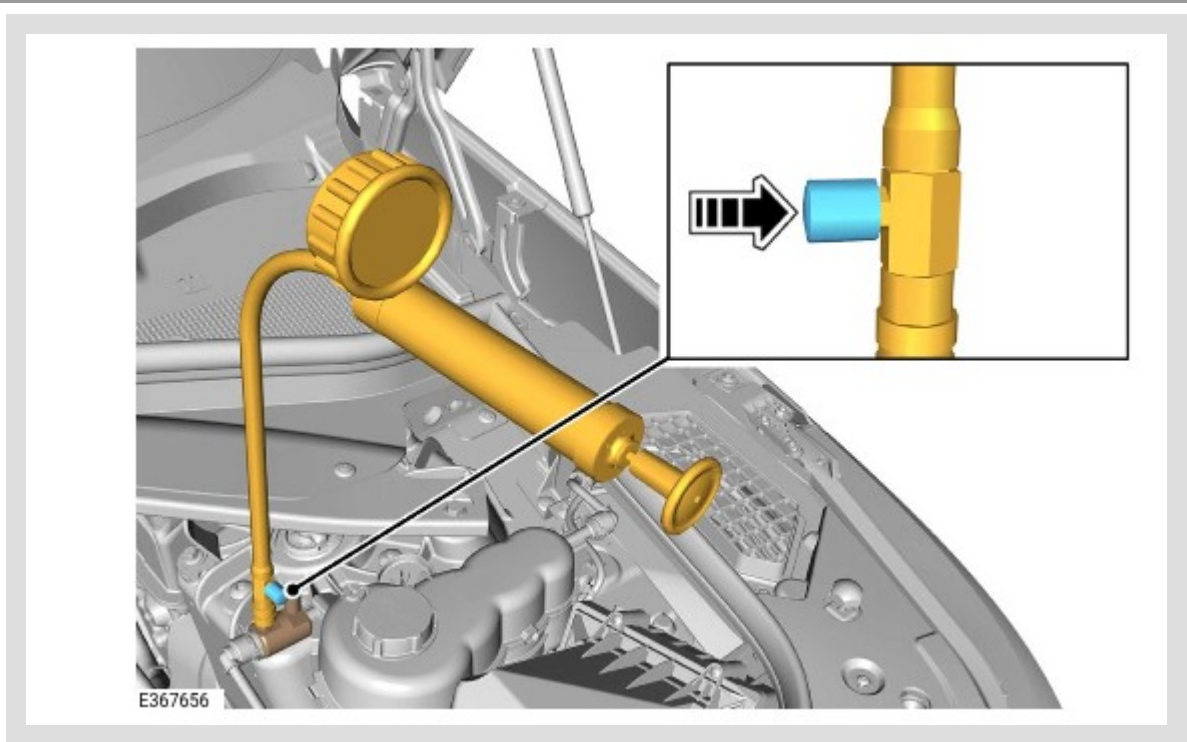

Depressurize and remove the cooling system pressure tester.

6. Disconnect the engine coolant vent pipe.

7. Remove the special tool.

*Special Tool(s):* [JLR-303-1720-01](#).

8.

**NOTE:**

Any related repairs must be claimed as a separate warranty claim.

Visually check the cooling system for signs of engine coolant leaks.

- If there **are** any visual signs of engine coolant leaks **do not** continue with this bulletin. Repair as necessary with reference to TOPIx.
- If there **are no** visual signs of engine coolant leaks complete the **SERVICE INSTRUCTION** section of this bulletin.

**SERVICE INSTRUCTION:**

**INGENIUM I6 3.0L Petrol, INGENIUM I6 3.0L Petrol PHEV Vehicles Only:**

- 
1. Remove the fuel supply line (see TOPIx Workshop Manual section 310-01: Fuel Tank and Lines - Removal and Installation - Fuel Supply Line).

**All Vehicles:**

---

2.

 **WARNING:**

**DO NOT** renew the coolant expansion tank if it was already renewed at step 2 of the INSPECTION.

Renew the coolant expansion tank (see TOPIx Workshop Manual section 303-03: Engine Cooling - Removal and Installation - Coolant Expansion Tank).

**INGENIUM I6 3.0L Petrol, INGENIUM I6 3.0L Petrol PHEV Vehicles Only:**

---

3.

Install the new fuel supply line (see TOPIx Workshop Manual section 310-01: Fuel Tank and Lines - Removal and Installation - Fuel Supply Line).

**All Vehicles:**

---

4.

Check the coolant concentration (see TOPIx Workshop Manual section 303-03: Engine Cooling - General Procedure - Cooling System Concentration Check).