



STAR ONLINE PUBLICATION



Case Number: S2323000074 Rev. A

Release Date: December 2024

Symptom/Vehicle Issue: Buzz Squeak Rattle (BSR) From Sound Bar Or Sport Bar Area.

Customer Complaint/Technician Observation: BSR noise may occur driving on rough roads or with high bass loud music.

Discussion: Using a helper to drive, duplicate the conditions necessary to create the BSR. Press upward on the sport bar trim to isolate the vibration (item 4 in Fig 1 below). If the noise is lessened or resolved with hand pressure, proceed with installing foam as shown below.

This document does not authorize warranty repairs. This communication documents a record of past experiences. STAR Online does not provide any conclusions about what is wrong with the vehicle. Rather, it captures all previous cases known that appear to be similar or related to the vehicle symptom / condition. You are the expert, and you are responsible for deciding on the appropriate course of action.

Contact STAR Center, or your Technical Assistance Center Via TechConnect, eCONTACT or Service Library entry if no solution is found.



STAR ONLINE PUBLICATION

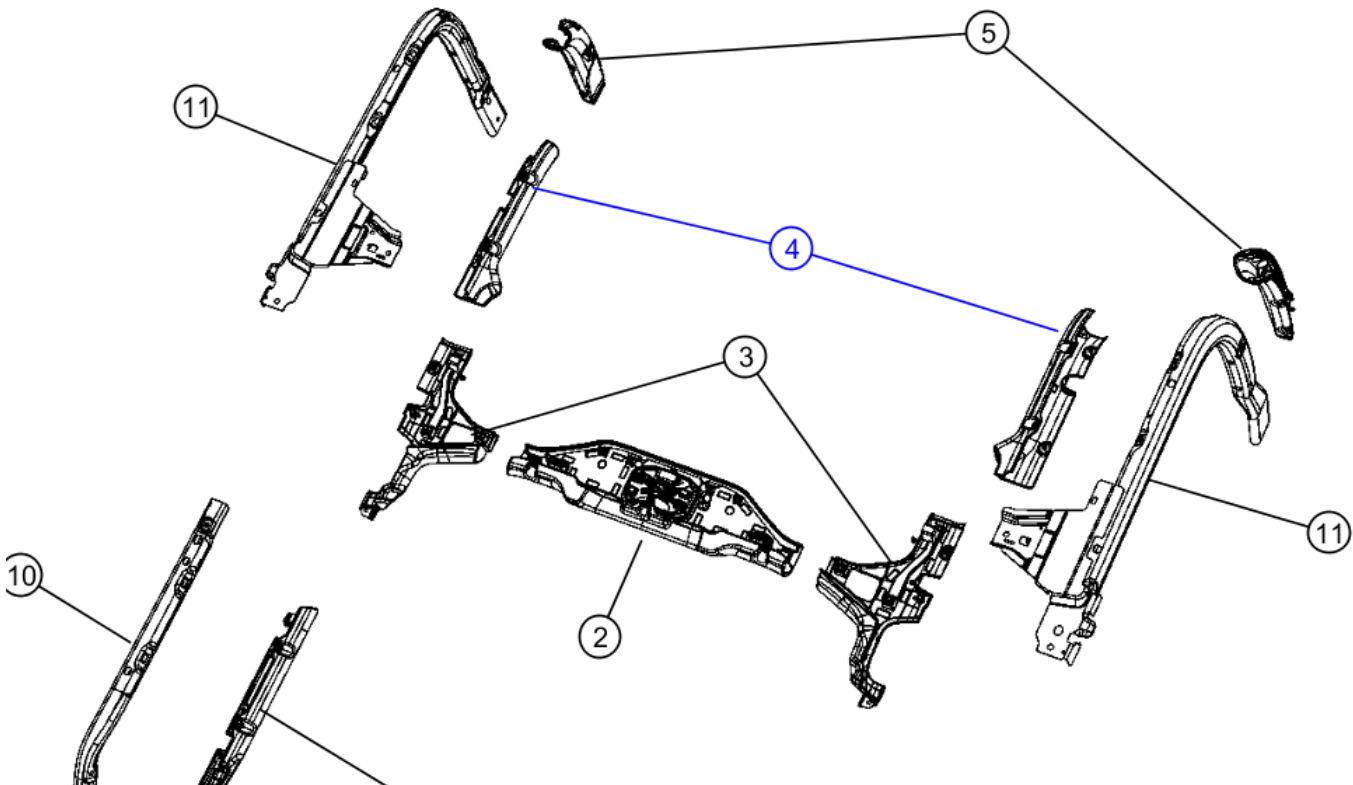

Fig 1.
Sport Bar Trim Item 4.

Remove the sport bar trim using a T25 torx bit. Review the foam application areas. Using isopropyl alcohol, wipe the area where foam is to be applied to remove grease, oils and dirt that may be present. Apply Mopar foam 68053426AA or 68643986AA on the underside of the sport bar trim as shown in Fig 2. Install foam on both right and left-hand sport bar trim as shown.

This document does not authorize warranty repairs. This communication documents a record of past experiences. STAR Online does not provide any conclusions about what is wrong with the vehicle. Rather, it captures all previous cases known that appear to be similar or related to the vehicle symptom / condition. You are the expert, and you are responsible for deciding on the appropriate course of action.

Contact STAR Center, or your Technical Assistance Center Via TechConnect, eCONTACT or Service Library entry if no solution is found.



STAR ONLINE PUBLICATION



Foam Material



B-D Mldg/Trim Left and Right equal



Foam placement on part



Close-up but not over edge



Fig 2.
Sport Bar Trim Removed. Foam application shown.

This document does not authorize warranty repairs. This communication documents a record of past experiences. STAR Online does not provide any conclusions about what is wrong with the vehicle. Rather, it captures all previous cases known that appear to be similar or related to the vehicle symptom / condition. You are the expert, and you are responsible for deciding on the appropriate course of action.

Contact STAR Center, or your Technical Assistance Center Via TechConnect, eCONTACT or Service Library entry if no solution is found.