



# Technical Service Bulletin

## 37 Noises after selecting a gear at idling speed when vehicle is stationary, noises when driving in different gears

37 24 28 2074806/2 November 22, 2024. Supersedes Technical Service Bulletin Group 37 number 24-20 dated July 31, 2024 for reasons listed below.

Model(s)	Year	VIN Range	Vehicle-Specific Equipment
A6	2016 – 2020	All	Not Applicable
A4	2017 – 2020		
A5, A5 Cabriolet, A5 Sportback, and Q5	2018 – 2020		
A7	2019	000001 - 046382	
	2020	All	
A6 allroad	2020		

### Condition

REVISION HISTORY		
Revision	Date	Purpose
2	-	Revised header (Adjusted models)
1	07/31/2024	Initial publication

### Customer States:

- Noises after selecting a gear at idle speed when the vehicle is stationary.

and/or

- Noises when driving in odd-numbered gears (1st, 3rd, 5th gear).

and/or

- Noises when driving in even-numbered gears (R, 2nd, 4th gear).

and/or

- Oil loss.



# Technical Service Bulletin

---

## Workshop findings:

- The customer complaint(s) can be reproduced.

and/or

- The noise in the vehicle interior can be reproduced (see Figure 1).



### NOTICE

**Note:** The noises change when a gear is selected/deselected (Figure 2).

For an example of the interior noise, see the video located at:

<https://audi-external.kzoplatform.com/player/medium/2800199503309706803>



*Figure 1. Example of interior noise*

For an example of the noise change with gear selected/deselected, see the video located at:

<https://audi-external.kzoplatform.com/player/medium/2800204564878333790>



*Figure 2. Example of noise change with gear selected/deselected*

and/or

- Noises from rear of gearbox (Figure 3).



# Technical Service Bulletin

---

## NOTICE

**Note: The noises change with the engine speed (Figure 4).**

For an example of the gearbox noise, see the video located at:  
<https://audi-external.kzoplatform.com/player/medium/2800197105174451664>



*Figure 3. Example of gearbox noise*

For an example of the noise change with engine speed, see the video located at: <https://audi-external.kzoplatform.com/player/medium/2800200895248209535>



*Figure 4. Example of noise change with engine speed*

**and/or**

- Noises from the area of the dual-mass flywheel (service flap).

**and/or**

- Evidence of ATF loss when the service flap is open.

**and/or**

- The noises can be allocated to accelerometer 1 and/or 2 using the Pico NVH tool (VAS 611015).
  - Please observe the instructions under Service.



# Technical Service Bulletin

---

and/or

- Abrasion visible on the permanent magnets of the oil pan (see Figure 5).



*Figure 5. Abrasion is visible on the permanent magnets of the oil pan.*

## Technical Background 1

Bearing A (Figure 9) on dual clutch.

## Production Solution

Not applicable.



# Technical Service Bulletin

---

## Service

### NOTICE

Try to reproduce the customer complaint (based on the description/workshop findings/event memory entries), so that it can be clearly assigned to this TSB. The following repair must only be carried out if all the criteria (model/type, chassis number, engine/gearbox code, PR number(s), part number, software version, code etc.) apply exactly. Otherwise, this measure will not eliminate the problem, and repeat repairs may be necessary. In such a case, we may reject the warranty claim and charge back the cost of the parts.

### Optional additional information through analysis with Pico NVH tool (VAS 611015):

- Attach acceleration sensors and microphone as described under “Measuring points\_page\_1” and “Measuring points\_page\_2”.



# Technical Service Bulletin

Messpunkte für Beschleunigungssensoren und Mikrofon  
/ measuring point for accelerometer and microphone

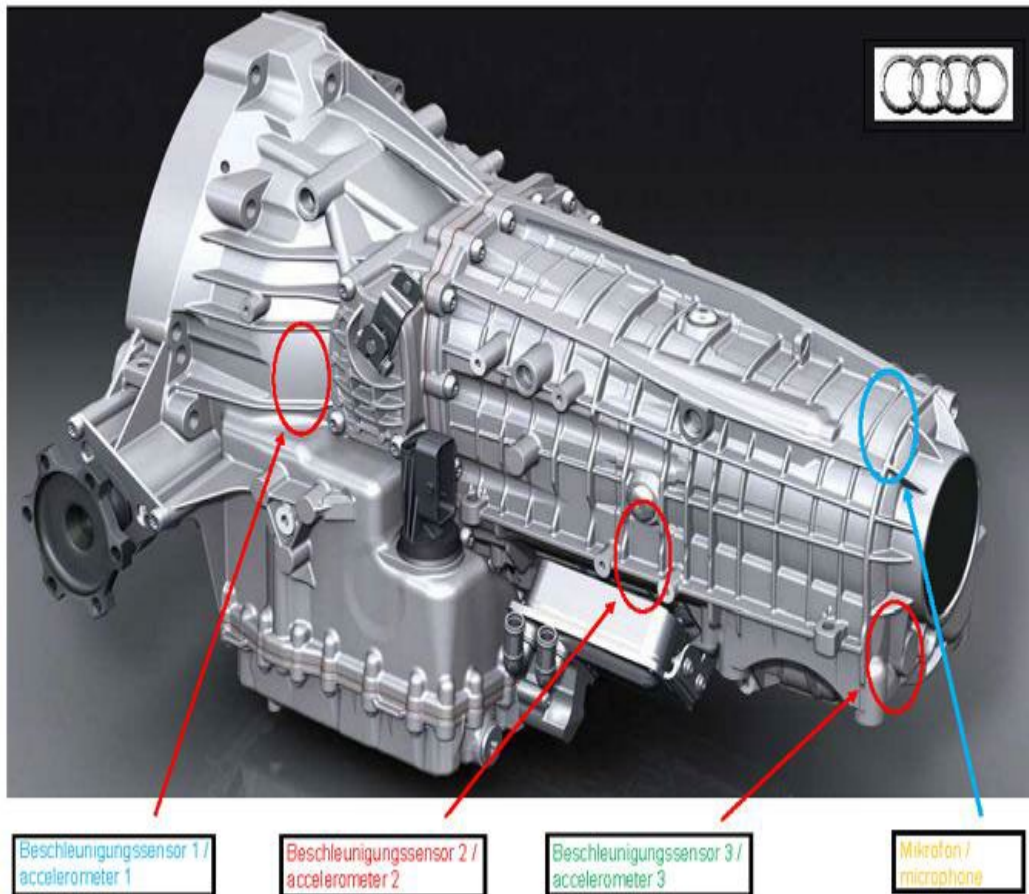

Figure 6. "Measuring points\_page\_1".



# Technical Service Bulletin

---

## Messpunkte für Beschleunigungssensoren und Mikrofon / measuring point for accelerometer and microphone





Kanal A / canal A	Kanal B / canal B	Kanal C / canal C	Kanal D / canal D
Beschleunigungssensor 1 / accelerometer 1	Beschleunigungssensor 2 / accelerometer 2	Beschleunigungssensor 3 / accelerometer 3	Mikrofon / microphone
			

Figure 7. "Measuring points\_page\_2".

- Analysis of the measurement via acceleration sensor 1/channel A and acceleration sensor 2/channel B.
  - Frequency range of approx. 250-600Hz can be detected here.

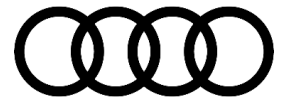

# Technical Service Bulletin

Auswertung der Messung / analysis of the measurement

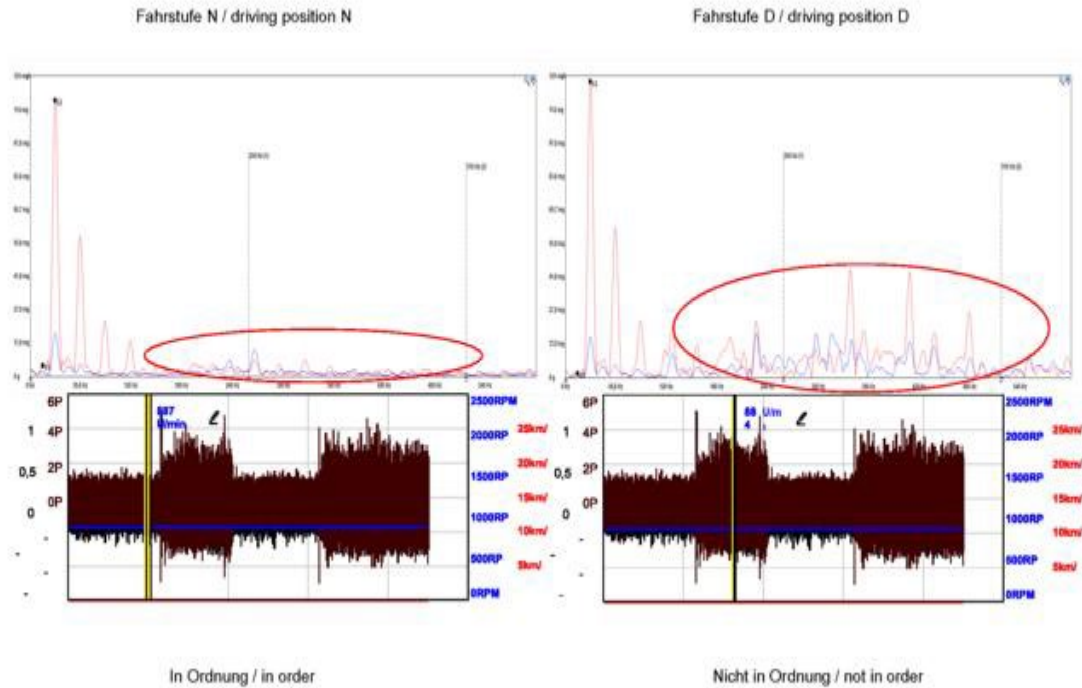
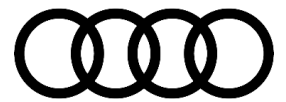

**Figure 8.** Please note the visualization showing a measurement in the attachment (“measurement” and “measurement1”).

**Please also provide an audio and/or video file and/or photos that clearly document your findings.**

Also perform a visual check of bearing A in cover for dual clutch and document your findings with detailed photos.

- To do so, remove the oil seal on bearing A (Figure 9 -> marked in red) of the dual clutch that was removed.
- Document any possible malfunctions of bearing A (see Figure 10 -> red arrow) with a photo clearly showing the issue.



# Technical Service Bulletin

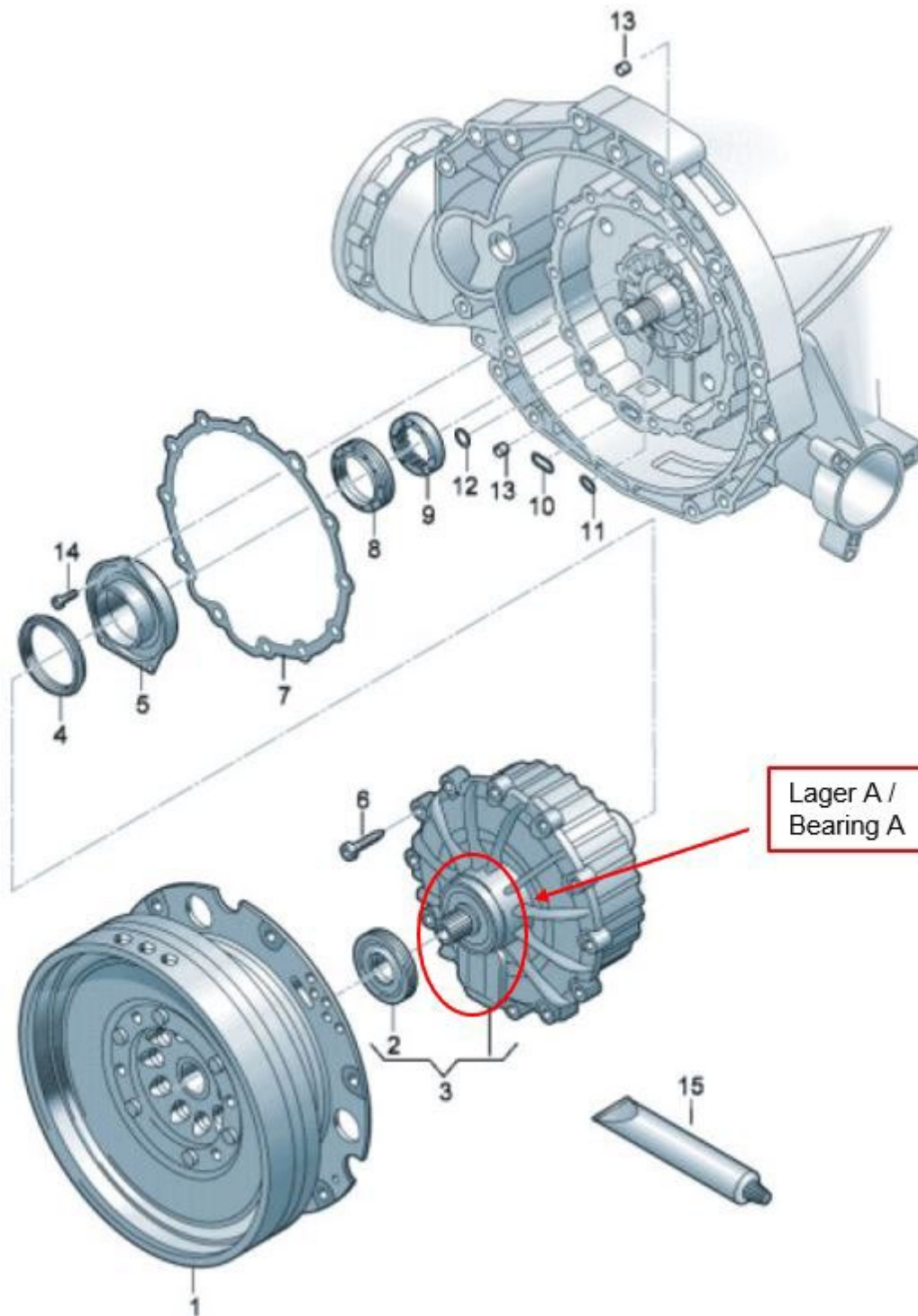
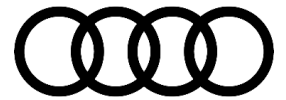
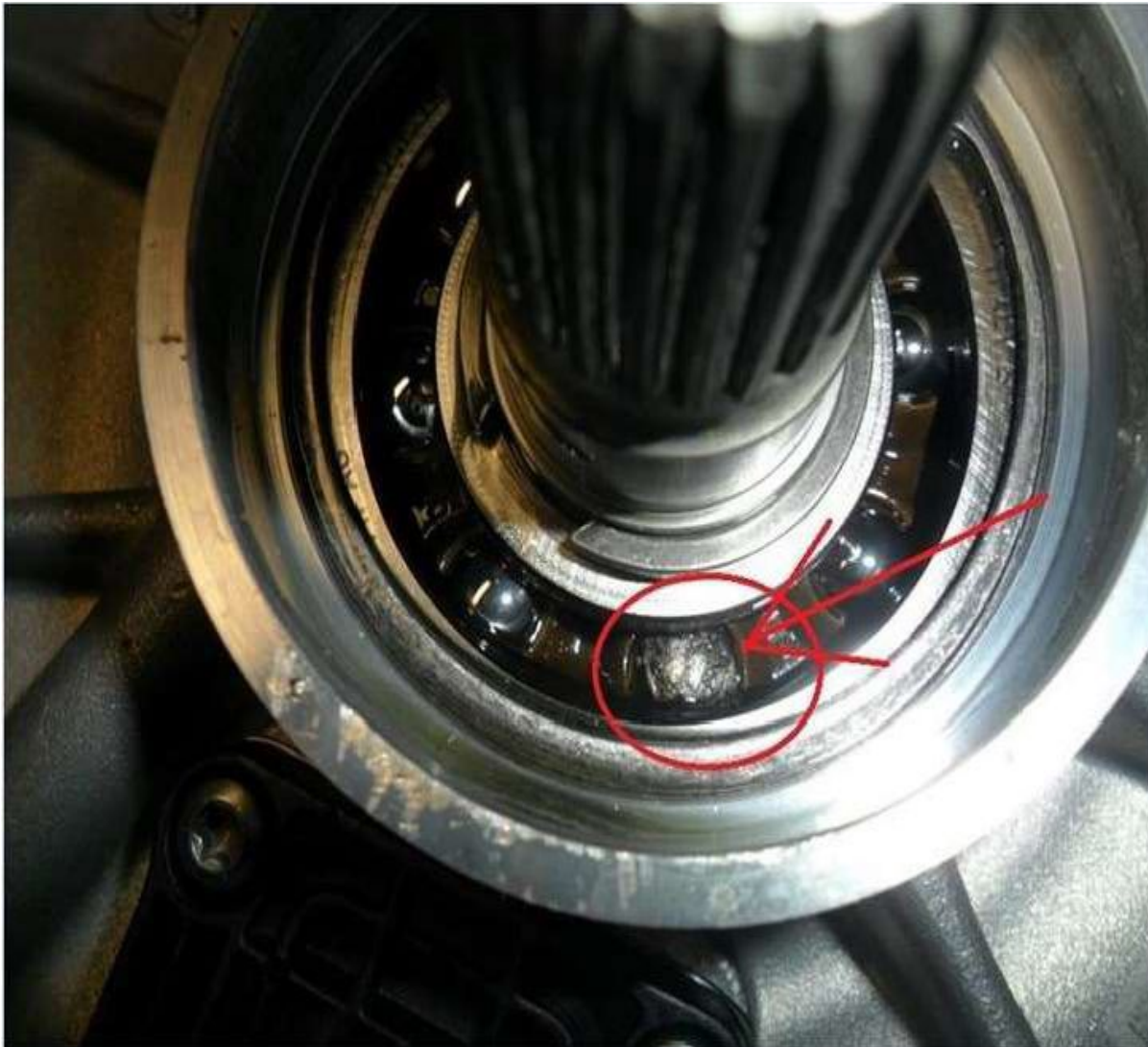

Figure 9. Bearing A on dual clutch.



# Technical Service Bulletin

---



*Figure 10. Bearing A circled, with red arrow.*

**Perform the following measures as described in the Workshop Manual:**

**1) Decision on repair level that can be performed -> based on repair work required for bearing A:**

- Replace bearing A in cover for dual clutch if you find the following functional issue on bearing A:
  - Wear can be seen on bearing A and ball cage is still in bearing A (see Figure 11).



# Technical Service Bulletin

---



Intellectual property rights of Audi of America, Inc., its affiliated companies, and its licensors. All rights are reserved to make changes at any time without notice. No part of this document may be reproduced, stored in a retrieval system, or transmitted in any form or by any means, electronic, mechanical, photocopying, recording, or otherwise, nor may these materials be modified or reposted to other sites, without the prior expressed written permission of the publisher.

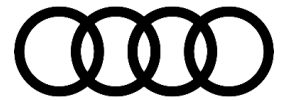

# Technical Service Bulletin

---

*Figure 11. Bearing A and ballcage.*

- Replace the entire dual clutch if you find the following functional issue in the installation space around bearing A:
  - Ball cage no longer in bearing A or irreparable damage to ball cage -> ball guidance no longer provided (see Figures 11 and 12).



*Figure 12. Damage is irreparable.*



*Figure 13. Damage is irreparable.*

## 2) Further repair steps:

- Replace the high-pressure filter, the low-pressure filter and the intake filter.
  - After removing the filter, thoroughly **clean** the valve body in this area and **avoid** getting it dirty.
- Replace the permanent magnets in the gearbox oil pan.
- Also replace the ATF.

**After completing the measures, carry out the following basic settings of the gearbox in the order listed here:**

- Calibration of clutch valves -N215,-N216.
- Calibration of movement sensors -G487...G490.

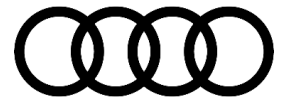

# Technical Service Bulletin

- Clutch engagement point adaptation.



**Do not delete any learnt values for the gearbox!**

**Do not complete the test plans of the Guided Fault Finding for:**

**Replacing gearbox; replacing mechatronic unit; and/or replacing valve body.**

**Do not update the gearbox software as part of this measure.**



**If the documentation of the test steps is incomplete (e.g. without photos), the warranty claim may be rejected.**



**A technical repair query is not necessary.**

## Warranty

<b>Claim Type:</b>	<ul style="list-style-type: none"> <li>• If the vehicle is outside of any warranty, this Technical Service Bulletin is informational only.</li> </ul>		
<b>Service Number:</b>	Dual Clutch Replacement: 3060, Bearing A replacement: 3059		
<b>Damage Code:</b>	Dual Clutch Replacement: 0010, Bearing A replacement: 0015		
<b>Labor Operations:</b>	Remove and install gearbox	3435 19xx	See SRT with associated operations
	Remove and install multiple clutch	3060 19xx	See SRT with associated operations

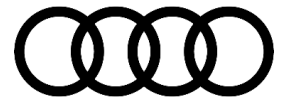

# Technical Service Bulletin

---

	Replace input shaft bearing	3545 5599	Please bill according to the time required
	Replace (all) oil filters (includes remove, install, and clean mechatronic unit)	3488 5599	190 TU
	Gearbox oil pan (replace magnet)	3460 5599	10 TU
	Check bearing (take photo of bearing)	3546 0199	10 TU
<b>Diagnostic Time:</b>	GFF	0150 0060	Labor according to the diagnostic log
	Set-up time for noise analysis tool	0161 0000	According to APOS
	Charge battery	2706 8950	According to APOS
<b>Claim Comment:</b>	As per TSB 2074806/2		

All warranty claims submitted for payment must be in accordance with the *Audi Warranty Policies and Procedures Manual*. Claims are subject to review or audit by Audi Warranty.

## Additional Information

All part and service references provided in this TSB (**2074806**) are subject to change and/or removal. Always check with your Parts Department and/or ETKA for the latest information and parts bulletins. Please check the Repair Manual for fasteners, bolts, nuts, and screws that require replacement during the repair.

©2024 Audi of America, Inc. All rights reserved. The information contained in this document is based on the latest information available at the time of printing and is subject to the copyright and other intellectual property rights of Audi of America, Inc., its affiliated companies, and its licensors. All rights are reserved to make changes at any time without notice. No part of this document may be reproduced, stored in a retrieval system, or transmitted in any form or by any means, electronic, mechanical, photocopying, recording, or otherwise, nor may these materials be modified or reposted to other sites, without the prior expressed written permission of the publisher.