

Trailer Hitch – Mechanical (1D6)

Change overview:

Version	Date	Change
1	02/10/2022	<ul style="list-style-type: none"> • First publication
2	06/09/2022	<ul style="list-style-type: none"> • Update of order types
3	11/04/2024	<ul style="list-style-type: none"> • Update of MY • Update of Parts Info • Update of PIWIS Tester version

Information: **Retrofitting**

Model Year: **As of 2022 up to 2025**

Restrictions: **Approved for: USA and Canada (C36).**

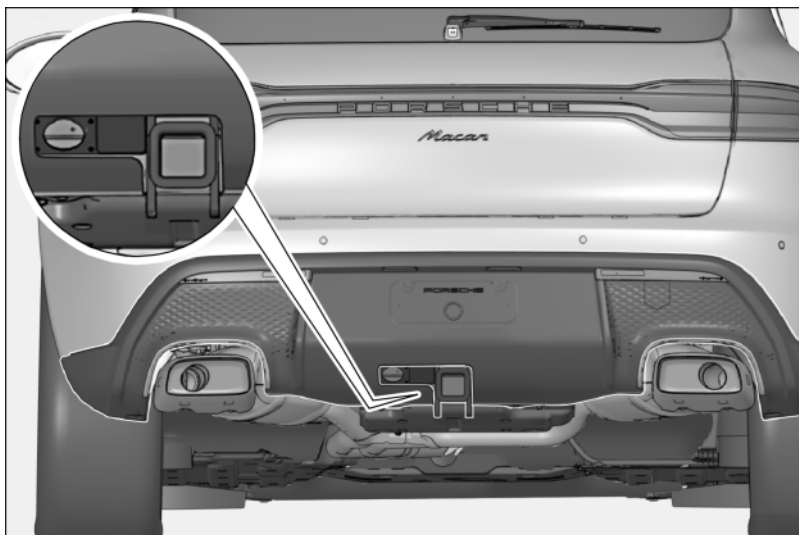

Figure 1 (USA version)

Note: The Macan can be retrofitted with a trailer hitch (⇒ *Figure 1 (USA version)*). Note the following special features:

- Permissible tongue weight of 200 kg/ 440 lbs
- Plug socket preparation for USA version
- Payload following installation, restricted by higher vehicle curb weight!
- Permissible total weight and axle load must not be exceeded!

The trailer hitch is also available ex works for new vehicles by requesting optional equipment "1D6 = Mechanical trailer hitch".



Information

Further information/technical values, instructions for using the trailer hitch and "Driving with a trailer" can be found in the:

- Macan Owner's Manual, topics: "Trailer Hitch", "More Safety and More Driving Pleasure" and "Weights"
- Vehicle registration documents

Parts Info: **95B.044.861** ⇒ Towbar system – mechanical – USA (1D6), set

Always order at the same time:

95B.807.883.B ⇒ Trailer hitch reinforcement (1D6) ⇒ *Figure 2--6--*

Parts list:

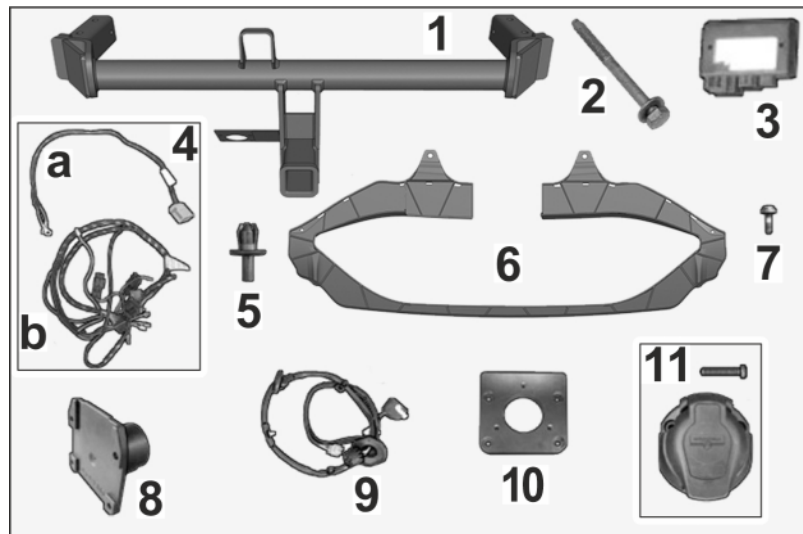

Figure 2

8R0.800.491.A	1 x	Trailer hitch ⇒ <i>Figure 2-1-</i>
N.907.721.02	4 x	Screw, M10 x 105 x 45 ⇒ <i>Figure 2-2-</i>
4H0.907.383.M	1 x	Control unit for mechanical trailer hitch ⇒ <i>Figure 2-3-</i>
95B.044.802.35	1 x	Wire harness (⇒ <i>Figure 2-4-</i>) consisting of:
— — —	1 x	Ground line for trailer hitch ⇒ <i>Figure 2-4a-</i>
— — —	1 x	Wire harness for control unit ⇒ <i>Figure 2-4b-</i>
PAF.038.501	2 x	Expansion rivet, 6 x 12 ⇒ <i>Figure 2-5-</i>

N.910.742.01	4 x	Screw, M5 x 16 ⇒ <i>Figure 2-7-</i>
7L0.803.593	1 x	Stopper for cover, square (not shown)
7L5.971.885 ¹	1 x	Cap (USA) ⇒ <i>Figure 2-8-</i>
95B.971.124 ¹	1 x	Wire harness (USA, not shown)

¹ Only contained in set 95B.044.861.

Materials:	— — —	1 x	30 amp fuse (commercially available)
	— — —	3 x	20 amp fuse (commercially available)
	— — —	1 x	Isopropanol (commercially available)
	— — —	1 x	Cloth

Tools:	Nr.88 - Torque angle torque wrench	VAS 6933 Disassembly tool
	P90999 - PIWIS Tester 4	Steel drill bit, Ø up to 8.0 mm
	Saw or vibrating knife	Drill
	Plastic wedge	Round/flat file
	Flashlight	Flat scraper
	Knife	

- Installing
- 1 Preparatory work
 - 1.1 Drive the vehicle onto a lifting platform.
 - 1.2 Disconnect the battery. ⇒ *Workshop Manual '2X00IN Work instructions after disconnecting the battery'*
 - 1.3 Remove rear apron. ⇒ *Workshop Manual '635519 Removing and installing rear apron'*
 - 1.4 Removing the center luggage compartment trim (load compartment cover). ⇒ *Workshop Manual '700619 Removing and installing centre luggage compartment trim (luggage compartment cover)'*
 - 1.5 Remove side luggage compartment trim panel (luggage compartment cover) . ⇒ *Workshop Manual '700619 Removing and installing side luggage compartment trim (luggage compartment cover)'*
 - 1.6 Removing cover for rear lock carrier. ⇒ *Workshop Manual '703919 Removing and installing cover for rear lock carrier'*
 - 1.7 Removing side trim panel for right luggage compartment. ⇒ *Workshop Manual '700319 Removing and installing side trim panel for rear luggage compartment'*
 - 1.8 Remove rear bumper (⇒ *Workshop Manual '635019 Removing and installing rear bumper'*)
 - 2 Electrical work in passenger compartment

- 2.1 Route and connect ground line
- 2.1.1 Disconnect pin connector socket, green (towbar system preparation) from the holder from the rear (⇒ *Figure 3*).
- 1 – Pin connector socket, green (towbar system preparation)
 - 2 – Bracket
 - 3 – Plug (socket) towbar system plug socket
- 2.1.2 Unlock pin connector socket (preparation) and push line BL 2.5² out of pin 6.
- 2.1.3 Unlock a new green pin connector socket (ground line) and push line BL 2.5² into chamber 6.
- Lock the new green pin connector housing (ground line).
- 2.1.4 Install green pin connector socket (ground line) into the holder from the rear (⇒ *Figure 4 -Arrow-*).
- 1 – Ground line
 - 2 – Cap nut for ground pin 42
- 2.1.5 Route ground line to ground pin 42 (rear, right) (⇒ *Figure 4*).
- 2.1.6 Install cable ring eyelets onto ground pin 42 and fasten loosely with cap nut (⇒ *Figure 4 -2-*). Another cable ring eyelet will be installed on the ground pin 42 later.
- 2.2 Install trailer hitch control unit and close it

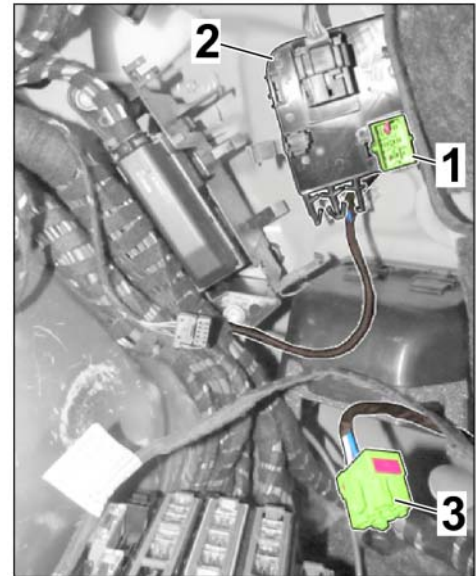

Figure 3

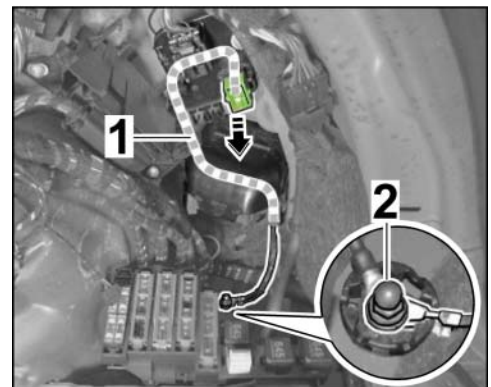

Figure 4

2.2.1 Clip trailer hitch control unit into bracket (⇒ *Figure 5*)

- 1** – Trailer hitch control unit
- 2** – Towbar system preparation
- 3** – Main wire harness
- 4** – Bracket



Information

Wire harness for trailer hitch preparation is secured to the main wire harness in the luggage compartment at the right ⇒ *Figure 4 -3-*.

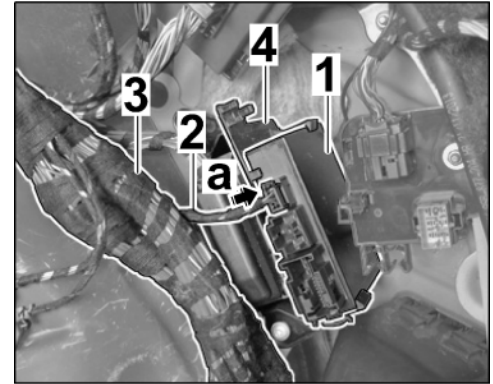

Figure 5

2.2.2 Disconnect towbar system preparation connector from main wiring harness.

2.2.3 Connect plug connection for trailer hitch preparation to the control unit (⇒ *Figure 5 -a-*).

2.3 Prepare control unit wire harness for installation

- A** – Wire harness for control unit (RdW version)
- B** – Wire harness for control unit (USA/Australia version)
- 1** – Branch for electric towbar system button

2.3.1 Remove branch for button for electric towbar system (⇒ *Figure 6 -1-*) and other branch from the RdW version wiring harness.

2.3.2 Complete wire harness USA/Australia version (⇒ *Figure 6 -B-*).

2.4 Connect branch for power supply (control unit wiring harness)

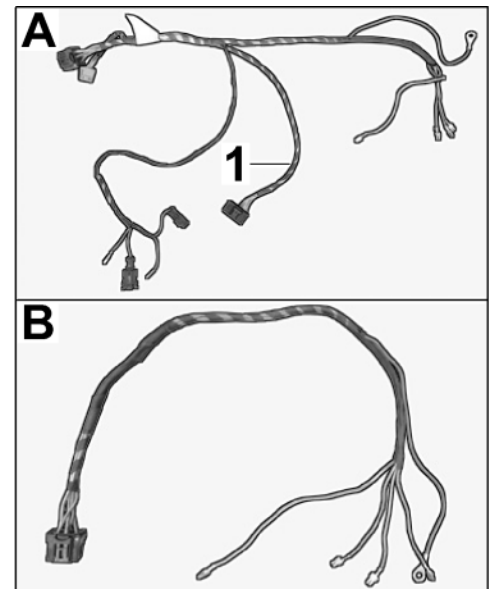

Figure 6

2.4.1 Loosen fuse box in the luggage compartment

- 1 - Hexagon nut
- 2 - Fuse box (luggage compartment)

Remove hexagon nut (⇒ *Figure 7*).

Pull fuse box (luggage compartment) out of the openings on the longitudinal member (⇒ *Figure 7-a*).

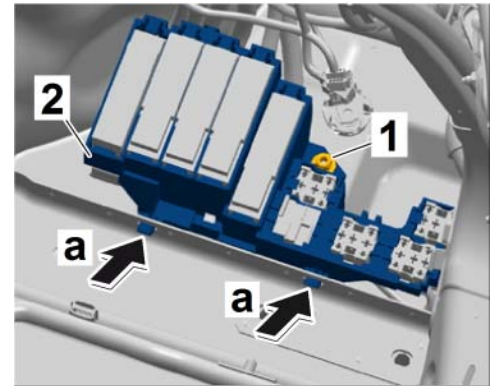

Figure 7

2.4.2 Release locks of fuse strip C and fuse strip B. Remove fuse strips B/C by pulling them down (⇒ *Figure 8* -Arrows-) out of the fuse box.

- 1 - Fuse strip B
- 2 - Fuse strip C
- 3 - Locking

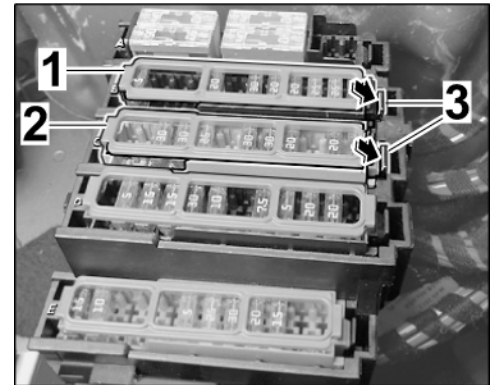

Figure 8

2.4.3 Release cap bottom from fuse strip B and C on both sides and unclip it (⇒ *Figure 9-a*).

- 1 - Locking
- 2 - Bottom cap

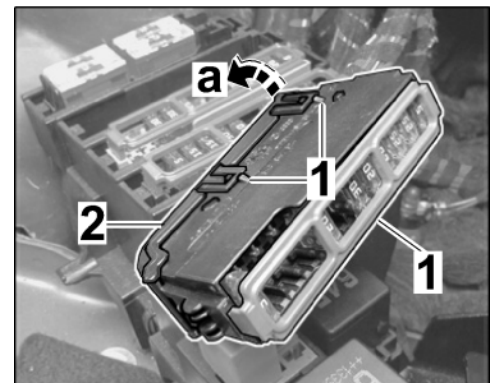

Figure 9

2.4.4 Use a screwdriver to open the secondary lock on fuse strips B and C (⇒ Figure 10-a).

- 1 - Secondary lock
- 2 - Screwdriver



Information

Ensure socket contact is seated securely.

2.4.5 Insert socket contacts into fuse strips B/C as follows:

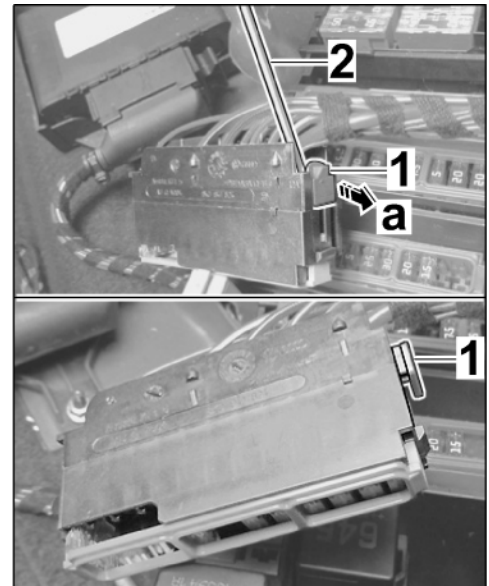

Figure 10

Fuse strip B, 1.5 mm ²		Chamber
RD/WH line	⇒	2
RD/YE line	⇒	3
RD/BU line	⇒	4

Fuse strip C, 2.5 mm ²		Chamber
RD/WH line	⇒	1

2.4.6 Close secondary lock on fuse strips B and C.

2.4.7 Install cap on fuse strips B and C.

2.4.8 Insert fuse strips C and B into the fuse box in the luggage compartment.

2.5 Securing fuse box in the luggage compartment.

- 1 – Hexagon nut
- 2 – Fuse box (luggage compartment)

2.5.1 Install fuse box (luggage compartment) into the openings on the longitudinal member (⇒ *Figure 11-a*).

2.5.2 Install hexagon nut.

2.6 Route and connect wire harness for control unit.

2.6.1 Route control unit wire harness to the trailer hitch control unit.

- 1 – Ground line for trailer hitch
- 2 – Ground pin 42
- 3 – Tie-wrap

Connect plug connection (⇒ *Figure 12-a*).

Secure control unit wire harness with a tie-wrap (⇒ *Figure 12-3*).

2.6.2 Route cable ring eyelet from ground line for trailer hitch (⇒ *Figure 12-1*) to ground pin 42 (⇒ *Figure 12-2*).

2.6.3 Secure cable ring eyelets from ground line for trailer hitch and ground line from control unit wire harness to ground pin 42.

Tightening torque 9 Nm (6.5 ftlb.)

2.7 Secure towbar system as shown in Figure 13 (⇒ *Figure 13*).

- 1 – 30-amp/fuse strip C
- 2 – 20-amp/fuse strip B
- 3 – 20-amp/fuse strip B
- 4 – 20-amp/fuse strip B

3 Installing the trailer hitch

3.1 **ONLY** Australia, New Zealand:
Install wire harness with trailer socket.

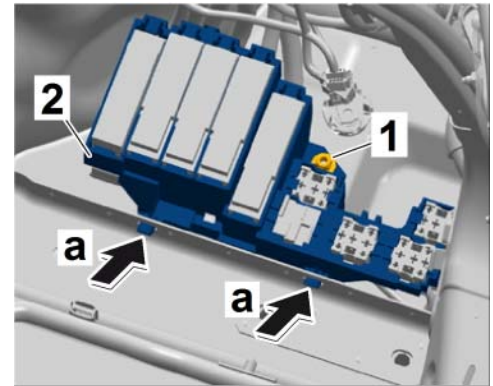

Figure 11

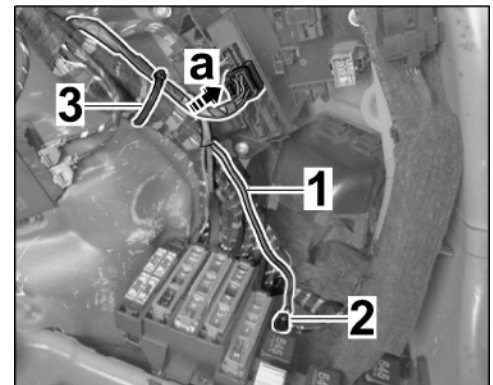

Figure 12

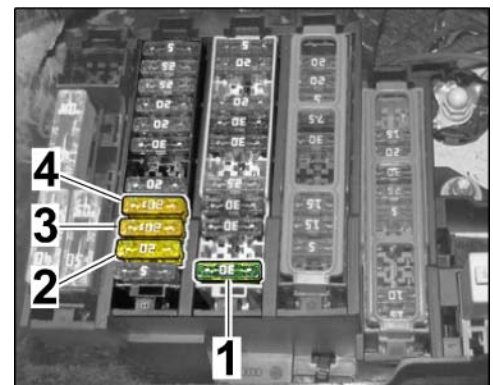

Figure 13

3.1.1 Install metal plate adapter with four screws M5 x 16 on towbar system (⇒ *Figure 14*).

- 1 – Adapter for metal plate
- 2 – Screw, M5 x 16

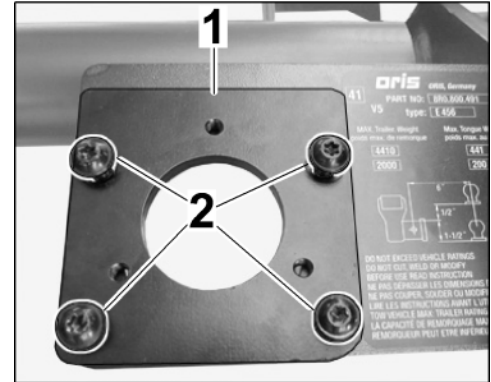

Figure 14

3.1.2 Thread trailer socket through holder plate on towbar system (⇒ *Figure 15-top*).

- 1 – Wire harness for trailer hitch
- 2 – Trailer socket
- 3 – Screw

Secure trailer socket on the holder plate with three screws (⇒ *Figure 15*).

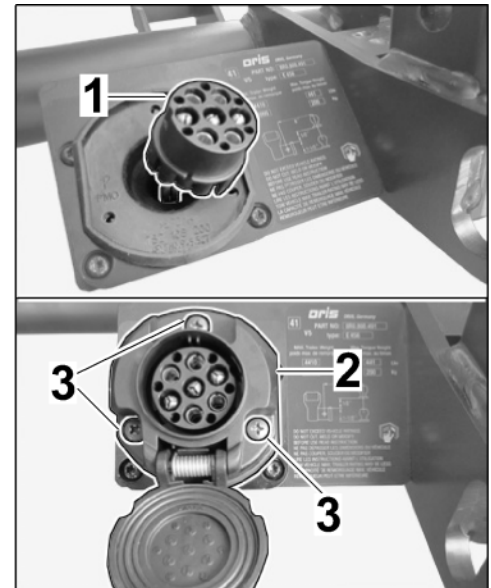

Figure 15

3.2 **ONLY USA, Puerto Rico:** Mount cap with four screws M5 x 16 onto holder plate of towbar system (⇒ *Figure 16*).

- 1 – Screw, M5 x 16
- 2 – Cover plate

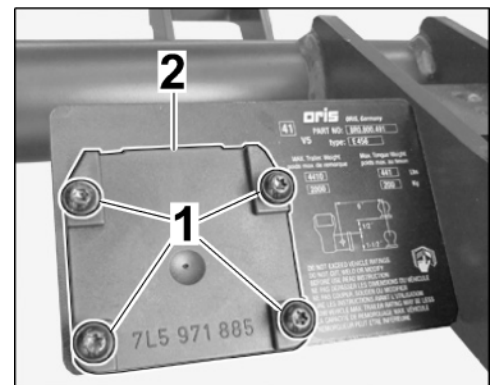

Figure 16

- 3.3 Remove dummy plug from rear closing panel
(⇒ *Figure 17*).

1 – Dummy plug

- 3.4 Installing the trailer hitch

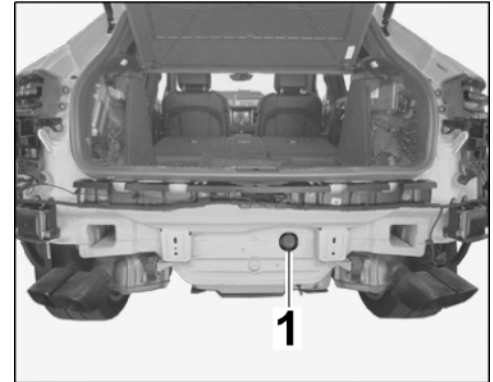

Figure 17

- 3.4.1 Insert towbar system guide profile into the longitudinal member on the vehicle, position it and secure it with four new screws, M10 x 105 x 45
(⇒ *Figure 18*)

1 – Screw, M10 x 105 x 45

Screw, M10 x 105 x 45 (4 ea.):
Tightening torque 50 Nm (37 ftlb.) +90°

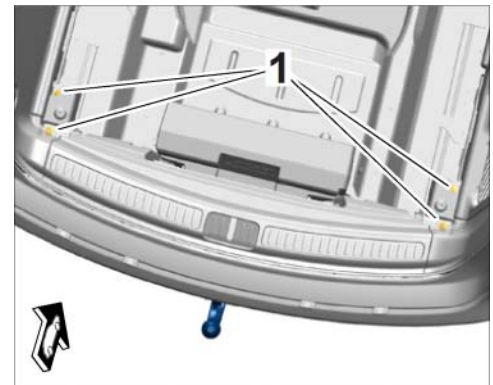

Figure 18

- 3.4.2 Guide wire harness for towbar system through rear closing panel into the boot.

1 – Cable clip

Install grommet in rear wall (⇒ *Figure 19 -Arrow-*)

Install cable clip (wire harness for towbar system) on bolt (⇒ *Figure 19-1-*).

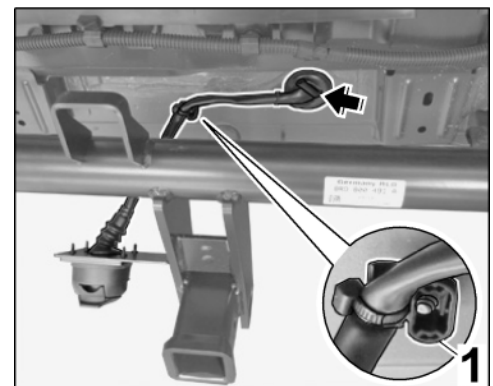

Figure 19

3.4.3 Route wire harness for trailer hitch (⇒ *Figure 20-1-*) to the trailer hitch control unit.

- 1 – Wire harness for trailer hitch
- 2 – Cable clip
- 3 – Bracket

Install cable clip (⇒ *Figure 20-2-*) on back panel.

Install wire harness for trailer hitch in the bracket (⇒ *Figure 20-3-*).

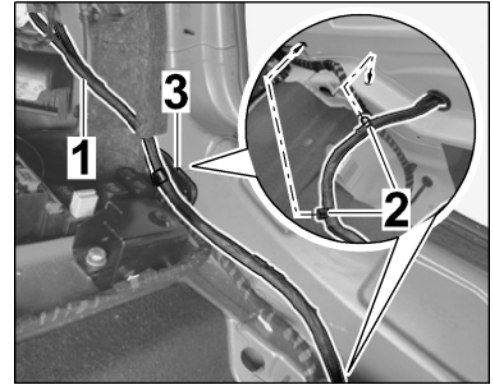

Figure 20

3.4.4 Connect plug connection for trailer hitch preparation (⇒ *Figure 21-1-*).

- 1 – Connection to towbar system preparation
- 2 – Towbar system control unit connection

Connect plug connection to the trailer hitch control unit (⇒ *Figure 21-2-*)

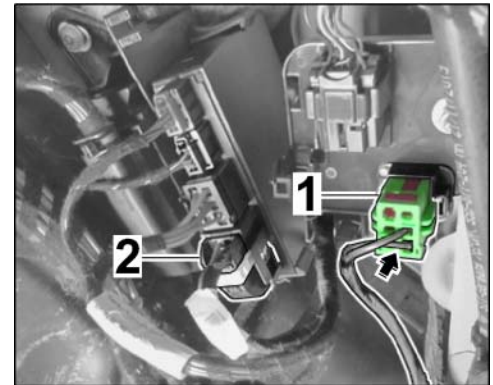

Figure 21

4 Concluding work

4.1 Convert rear panel

4.1.1 Remove rear panel. ⇒ *Workshop Manual '635619 Removing and installing rear panel'*

- 4.1.2 Mark the cut-out for the trailer hitch along the impression (\Rightarrow *Figure 22 -1-*) on the inside of the rear panel so that it is clearly visible using a pen.

- 1** – Marking
2 – Cut-out



Information

Mask the sawing area to prevent damage.

- 4.1.3 Carefully make the cut-out using a drill and saw along the marking (\Rightarrow *Figure 22*).

- 4.1.4 De-burr cut edges (\Rightarrow *Figure 22-2-*) with a knife or file.

- 4.1.5 Clean the inside of the rear panel to remove any dust and grease (isopropanol cleaner).

- 4.1.6 Pull protective film (\Rightarrow *Figure 23 -1-*) off the reinforcement (\Rightarrow *Figure 23-2-*).

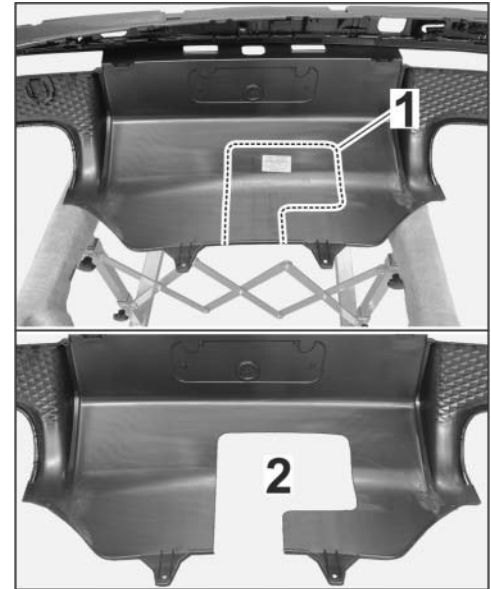

Figure 22

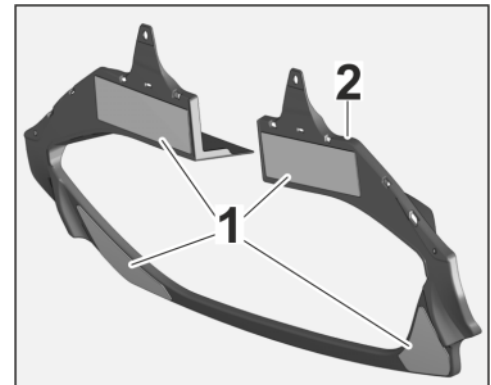

Figure 23

4.1.7 Insert reinforcement perfectly into the rear panel. Fastening bores (⇒ *Figure 24-1-*) and bores for expansion rivets (⇒ *Figure 24-2-*) must be covered exactly.

- 1 - Fastening bore
- 2 - Expansion rivet bore
- a - Bonding area

4.1.8 Press reinforcement firmly onto the rear panel (⇒ *Figure 24-a-*).

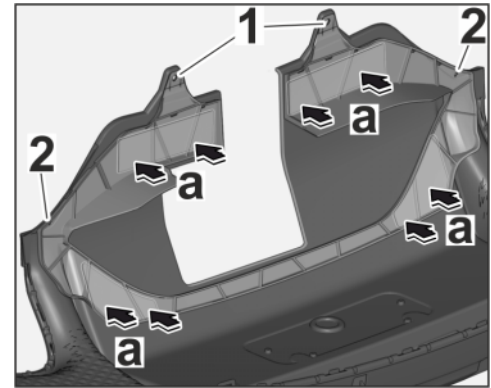

Figure 24

4.1.9 Secure the reinforcement with expansion rivets (2 ea.) (⇒ *Figure 25-1, 2-*).

4.1.10 Install rear panel. ⇒ *Workshop Manual '635619 Removing and installing rear panel'*

4.2 Install side trim panel for right luggage compartment. ⇒ *Workshop Manual '700319 Removing and installing side trim panel for rear luggage compartment'*

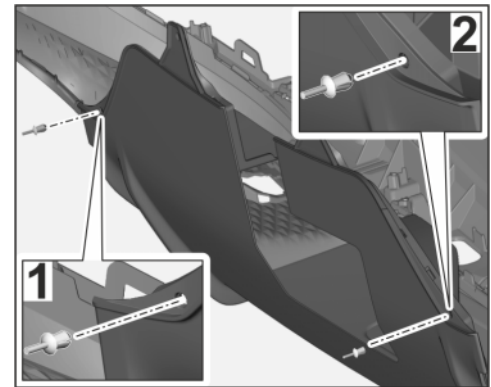

Figure 25

4.3 Install cover for rear lock support. ⇒ *Workshop Manual '703919 Removing and installing cover for rear lock carrier'*

4.4 Install (side) luggage compartment trim panel (luggage compartment cover). ⇒ *Workshop Manual '700619 Removing and installing side luggage compartment trim (luggage compartment cover)'*

4.5 Install (center) luggage compartment trim panel (luggage compartment cover). ⇒ *Workshop Manual '700619 Removing and installing centre luggage compartment trim (luggage compartment cover)'*

4.6 Install rear apron. ⇒ *Workshop Manual '635519 Removing and installing rear apron'*

4.7 Connect the battery. ⇒ *Workshop Manual '2X00IN Work instructions after disconnecting the battery'*

Coding: 5 Enter trailer hitch (1D6) in the vehicle data

5.1 Preparatory work – Coding

5.1.1 Connecting a battery charger. ⇒ *Workshop Manual '270689 Charging vehicle electrical system battery'*

NOTICE**Voltage drop**

- Risk of irreparable damage to control unit
 - Risk of damage to control unit
 - Fault entries in the control unit
 - Coding in the control unit is aborted
 - Malfunctions in control unit, even during programming
- ⇒ Prior to disconnecting the control unit, switch off ignition and remove ignition key.
- ⇒ Ensure that the power supply is not interrupted during programming.
- ⇒ Connect a battery charger with a current rating of at least 90 A to the vehicle battery.

NOTICE

Control unit programming will be aborted if the WLAN connection is unstable.

- An unstable WiFi connection can interrupt communication between the PIWIS Tester and the vehicle communication module (VCI). As a result, control unit programming may be aborted.
- ⇒ During control unit programming, always connect the PIWIS Tester to the vehicle communication module (VCI) via the USB cable.

5.1.2 **P90999 - PIWIS Tester 4** must be connected to the vehicle and switched on.

5.1.3 Switch on ignition **AND** hazard warning lights on the vehicle.

**Information**

The **PIWIS Tester** instructions take precedence since the description may be different with later Tester releases.

The procedure described here has been structured in general terms. Different text or additional information may appear on the **PIWIS Tester**.

5.1.4 Select the "Diagnostics" PIWIS Tester menu item.

5.1.5 If **P90999 - PIWIS Tester 4** is connected correctly, a connection to the vehicle will be established: The model line is detected: "Macan" model line is detected.

5.1.6 Create a vehicle analysis log (VAL) in the "Overview" menu item.

**Information**

The function is **ONLY** available when the Tester is online!

- 5.2 Enter the new vehicle equipment in the vehicle data using "PIWIS Online"
- 5.2.1 Select the function "Maintenance of vehicle data with PIWIS ONLINE" in the "Model line-specific tests and campaigns" menu item.
- A message appears informing you that the "Actual" (vehicle) data and "Required" (PIWIS Online) data will be compared.
- Press •F12" to continue.
- 5.2.2 Confirm the message "The vehicle data was compared with PIWIS Online. Significant differences were found" with •F12" .
- 5.2.3 Look for the option "TRAILER HITCH" in the "Family" column.
- Select the value "1D6 - TRAILER HITCH WITHOUT BALL JOINT (USA)" in the drop-down menu. Press •F12" to continue
- 5.2.4 A table containing the coding value and the columns "new value" and "old value" is displayed in the overview. Press •F8" to continue.
- 5.2.5 Data is then written/stored. The following messages appear one after the other:
- Transferring vehicle data to PIWIS Online.
 - Writing and transferring vehicle data to the vehicle.
 - Vehicle order was written successfully.
 - A check was performed in order to check whether control units have to be coded as a result of the changes that were made.
- 5.2.6 Press •F10" to open the log. Check that the selected vehicle equipment has been entered and close the log.
- 5.3 Code/program the new vehicle equipment(s)
- 5.3.1 Confirm the table containing a list of control units that must be coded/programmed by pressing •F12" .
- 5.3.2 Individual data records will be loaded, depending on the number of control units to be coded/programmed.
- Wait until messages "Creating backup documentation. Please wait..." and "Coding was completed successfully". Press •F12" to continue.
- Repeat the process for other control units if necessary.
- 5.3.3 Wait for the "Adaptation of the control units is complete." message and check the coding status of the control units in the table displayed.
- Continue by pressing •F12" to return to the control unit overview.
- 5.4 Read out the fault memory of all systems, work through any existing faults, and erase the fault memory (⇒ *Workshop Manual '0335IN Maintenance diagnosis: Diagnostic system and maintenance inter...*).
- 5.5 Create a vehicle analysis log (VAL) in the "Overview" menu item.

- 5.6 Switch off ignition and disconnect **P90999 - PIWIS Tester 4**.
- 5.7 Disconnect the battery charger. ⇒ *Workshop Manual '270689 Charging vehicle electrical system battery'*

66 90 23 03: –Retrofitted (mechanical) trailer hitch– Labor time: **235 TU**
Includes: Removing and installing rear apron, real panel working out cut-out in rear panel, installing rear panel reinforcement, installing and coding trailer hitch.

ONLY for vehicles with Lane Change Assist/Lane Keep Assist (611/613/7Y1):

91 70 25 53: Program Lane Change Assist control unit; Labor time: **47 TU**
Includes: Measure calibration plate on the vehicle.

ONLY vehicles with reversing camera (KA2) and reversing camera including Surround View (KA6):

91 72 25 50: Program Surround View camera control unit Labor time: **62 TU**

Important Notice: Technical Bulletins issued by Porsche Cars North America, Inc. are intended only for use by professional automotive technicians who have attended Porsche service training courses. They are written to inform those technicians of conditions that may occur on some Porsche vehicles, or to provide information that could assist in the proper servicing of a vehicle. Porsche special tools may be necessary in order to perform certain operations identified in these bulletins. Use of tools and procedures other than those Porsche recommends in these bulletins may be detrimental to the safe operation of your vehicle, and may endanger the people working on it. Properly trained Porsche technicians have the equipment, tools, safety instructions, and know-how to do the job properly and safely. Part numbers listed in these bulletins are for reference only. The work procedures updated electronically in the Porsche PIWIS diagnostic and testing device take precedence and, in the event of a discrepancy, the work procedures in the PIWIS Tester are the ones that must be followed.

© 2024 Porsche Cars North America, Inc.