



PROTERRA



TECHNICAL SERVICE BULLETIN

ISSUE DATE:	2-22-2022
SERVICE BULLETIN SUBJECT:	35 Foot 800 Volt Accelerator Pedal Overlay Harness Retrofit
VINs or MODELS AFFECTED:	Service Specified Buses
COMPLETE BY:	Next Service Opportunity
SERVICE BULLETIN #:	SC-22-16
LABOR OPERATION CODE:	DE45Z

NOTICE! It is expected that this process will require three (3) hours per bus. Please schedule appropriately to minimize vehicle downtime.

35 FOOT 800 VOLT ACCELERATOR PEDAL OVERLAY HARNESS RETROFIT

Retrofit Description:

This procedure describes the process of adding an Overlay Harness between the Accelerator Pedal and the Drive Train for improved performance.

Tools/Parts Required

Tools and Supplies Required:

- Side Cutting Pliers
- Wire Strippers
- Ratchet
- 10mm Socket
- Calibrated Torque Wrench
- Orange Torque Stripe Paint

Kit Parts Required:

- 060543 RETROFIT - 35' ACCELERATOR PEDAL LAYOVER HARNESS (Consisting of)
 - 136-6794 HARNESS, ACCELERATOR PEDAL OVERLAY (ACCL) 1 EA
 - 048194 SEAL, ICOTEK 1 EA

Additional Parts Required:

- 001911 CABLE TIE, STANDARD CROSS SECTION, 7.5 BLACK" 25 EA
- 012138 CABLE TIE, HEAVY DUTY .5WIDE 9.1" BLACK 15 EA

Procedure

1. Complete the Proterra approved Lockout/Tagout procedure to make the bus safe for work.
2. Working underneath the Steering Wheel, locate and disconnect the Connectors labeled JD082 and JD083.

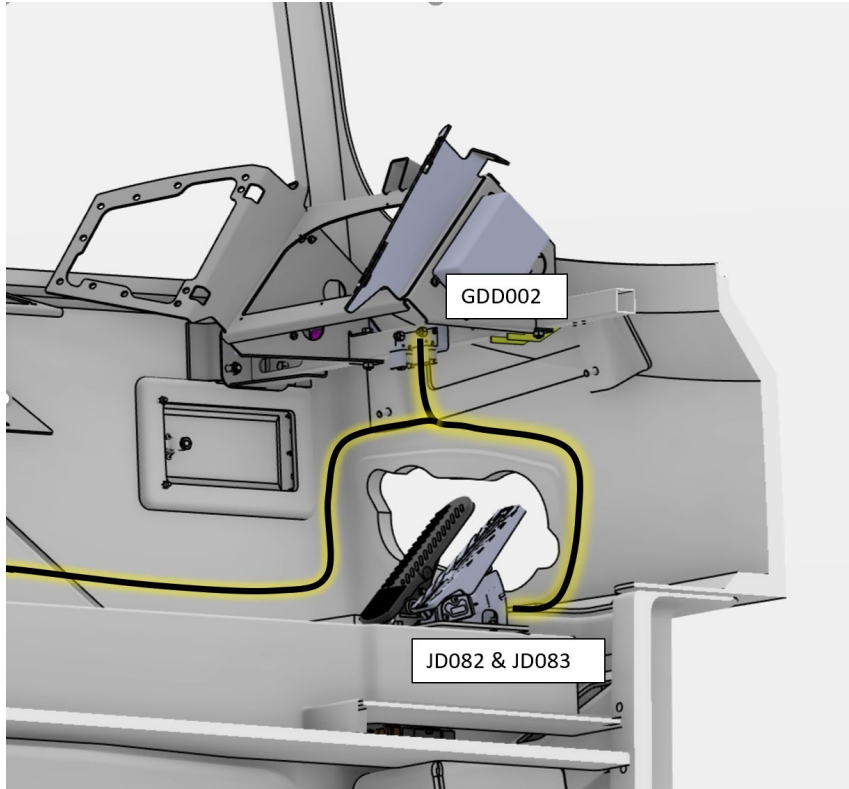

3. Using a 10mm Ratchet/Socket, remove the Ground Lug from Ground Block GDD002 underneath the dash. Retain the Washer and Nut to use later. The Ground Block is shown below in the Parts Manual View.

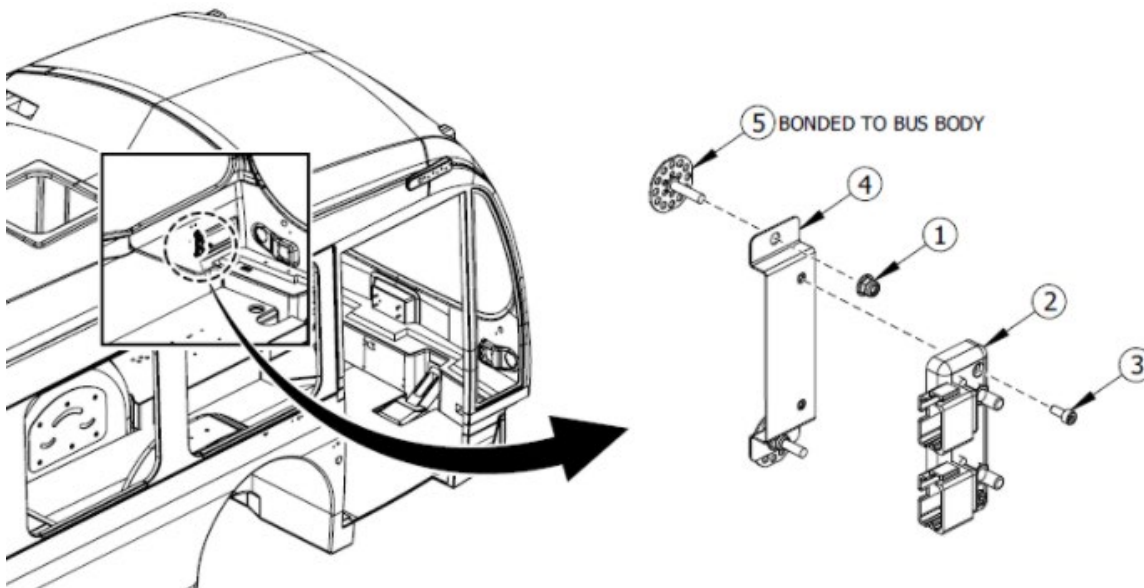

- Using a T-30 Torx Driver, loosen or remove the panels necessary to route the new Harness through the Armrest and up through the ECAB to the Hadley Panels as shown in the following illustration.

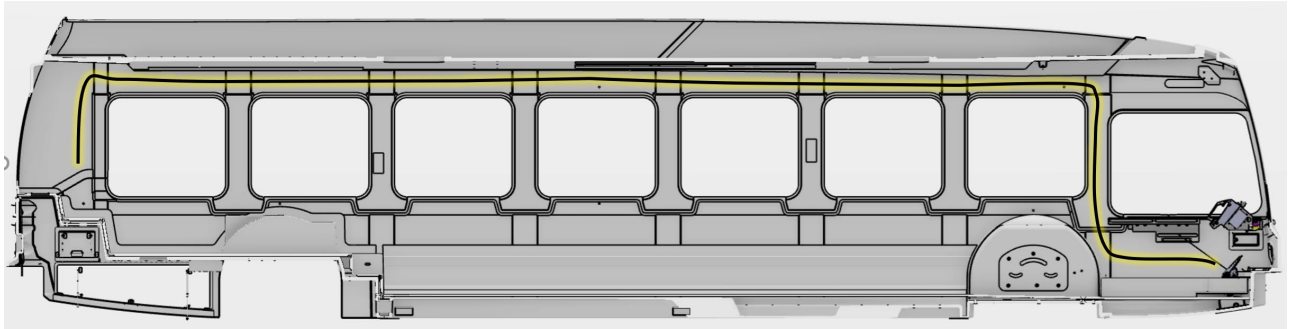

- Roll up the free end of the disconnected Harness and place it behind the Armrest.
- Using a 4mm Allen Driver, open all the Hadley Panels on the streetside of the bus.
- Connect the new Harness (136-6794) to the Accelerator Pedal using Connectors JD082 and JD083.
- Using a 10mm Ratchet/Socket, connect the Ground Lug on the new Harness (136-6794) to the Ground Block labeled GDD002 underneath the dash using the original hardware.
- Using a Calibrated Torque Wrench with a 10mm Socket, **torque the nut to 11 foot-pounds.**
- Using Orange Torque Stripe Paint, mark the properly torqued fastener.
- Route the free end of the new Harness (136-6794) back through the path shown in the following illustration. Keep the Harness as far away from High-Voltage cables as possible. If the Harness must cross High-Voltage cables, it should cross at a right angle.

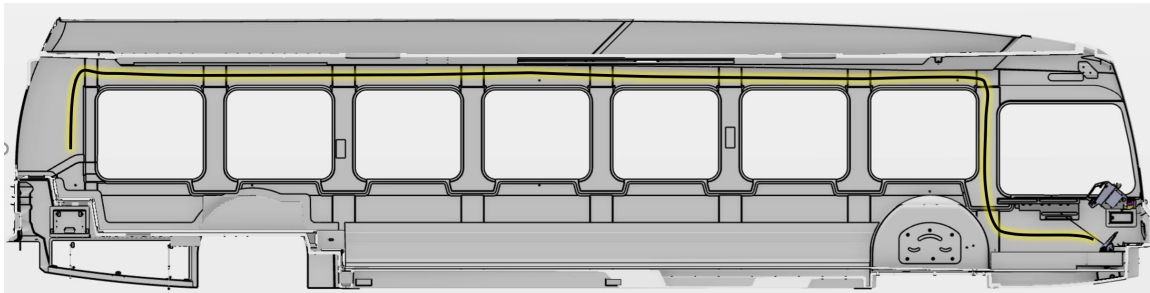

12. Working inside the bus at the streetside rear, remove any panels necessary to route the new Harness (136-6794) down through the rear deck of the bus as shown in one of the following illustrations. The illustration on the left is a current ZX5 Bus. The illustration on the right represents earlier models.

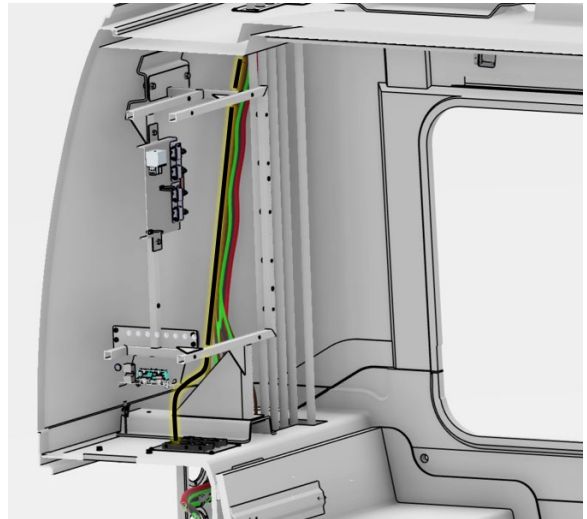
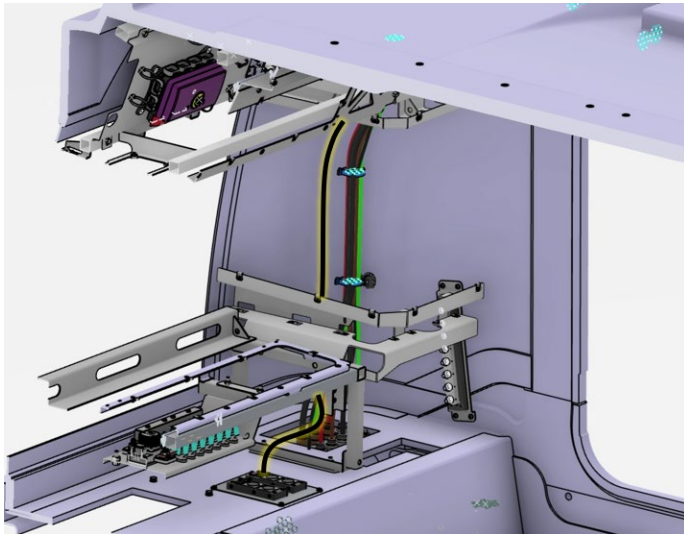

13. Remove one of the unused Cable Glands from the Icotek Pass-Through at the rear of the bus.

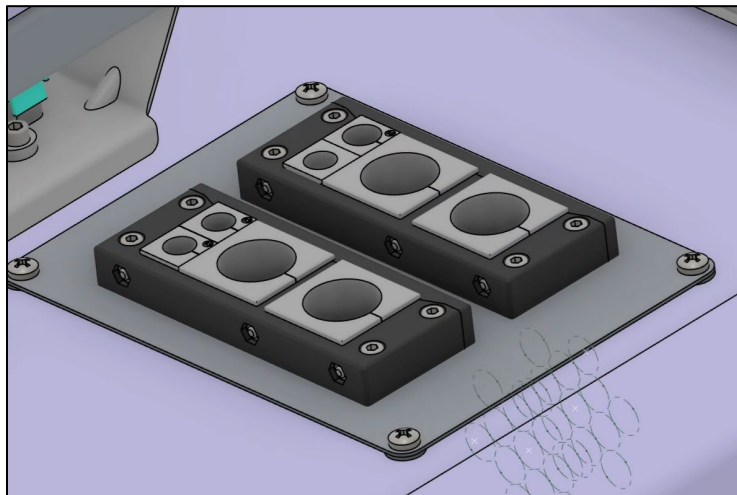

14. Feed the free end of the new Harness (136-6794) down through the rear deck.

15. Secure the Harness (136-6794) in the Pass-Through with a new Seal (048194).

16. Route the free end of the new Harness (136-6794) as shown highlighted in yellow in the one of the following illustrations. The illustration on the left is a current ZX5 Bus. The illustration on the right represents earlier models. The Harness should be routed with the Air Lines and Low-Voltage cables. If the Harness must cross High-Voltage cables, it must cross them at right angles.

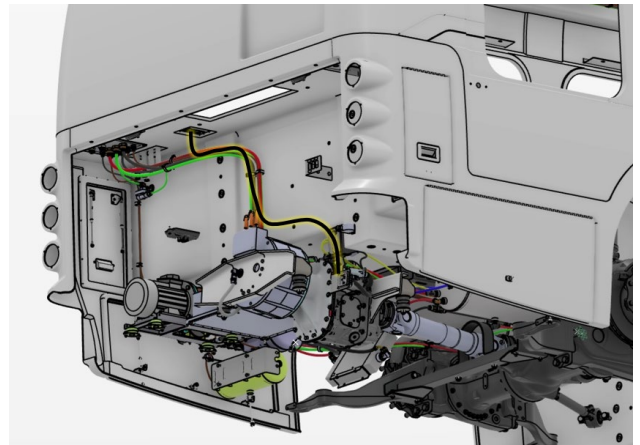
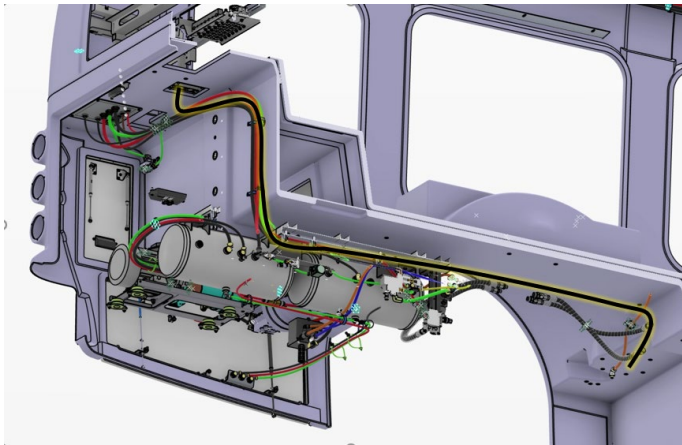

17. Locate the connector labeled PM152 on the Drive and disconnect it.

NOTE: The mating connectors for a Duopower Drive and a Prodrive are shown below for reference.

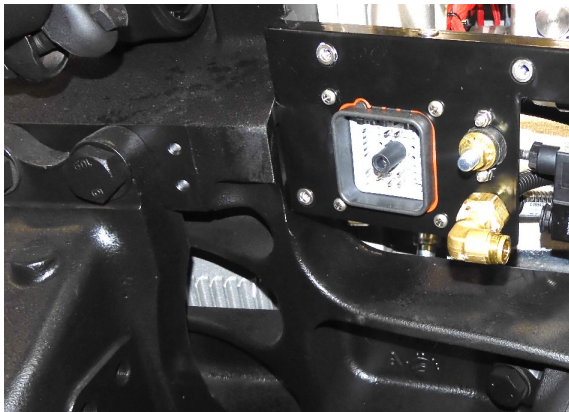

18. Using a Pin Extractor, remove the terminals installed into Cavities 37, 28, 39, and 40.

19. Install the terminals on the new Harness (136-6794) into their respective Cavities on PM152. The terminals are labeled for the proper Cavities.

20. Reconnect PM152 to the Prodrive.
21. Using Cable Ties (001911 and 012138), secure the Harness along the length of its route.
22. Using a 4mm Allen Driver, close and secure the Hadley Panels.
23. Using a T-30 Torx Driver, replace any panels that were removed including the Armrest.
24. Remove the Lockout/Tagout devices and return the bus to service.