



# Service Bulletin

Bulletin No.: 24-NA-145

Date: October, 2024

## TECHNICAL

**Subject: Malfunction Indicator Lamp (MIL) Illuminated - DTC P219A Set as Current or History**

**This bulletin replaces PIP5986A. Please discard all versions of PIP5986.**

Brand:	Model:	Model Year:		VIN:		Engine:	Transmission :
		from	to	from	to		
Buick	Enclave	2024	2025			2.5 LK0	
Chevrolet	Traverse						
GMC	Acadia						

<b>Involved Region or Country</b>	North America
<b>Condition</b>	Some customers may comment on the MIL illuminated. Some technicians may find DTC P219A set as current or history.
<b>Cause</b>	This condition may be caused by the Signal/Ground wires are not shielded or twisted and are receiving noise from the HO2S Bank 1 Sensor 1 power circuit.
<b>Correction</b>	Install Jumper Wiring Harness from the PCM to the HO2S.

**Important: Service agents must comply with all International, Federal, State, Provincial, and/or Local laws applicable to the activities it performs under this bulletin, including but not limited to handling, deploying, preparing, classifying, packaging, marking, labeling, and shipping dangerous goods. In the event of a conflict between the procedures set forth in this bulletin and the laws that apply to your dealership, you must follow those applicable laws.**

### Service Procedure

1. Disconnect the battery negative cable.
2. Remove the Air Cleaner Outlet Duct. Refer to *Air Cleaner Outlet Duct Replacement* in SI.

**Note:** The wiring from the PCM X3 connector cavity 48 routes to cavity 3 and cavity 49 routes to cavity 4 in the HO2S connector.

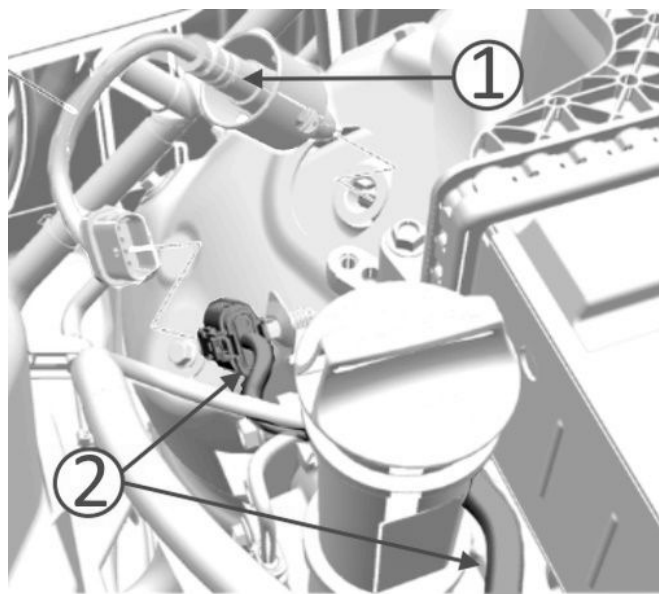

6709693

3. Starting at the HO2S, disconnect the HO2S (2) electrical connector.
4. Using care, remove the wire harness tape a few inches down from the connector.

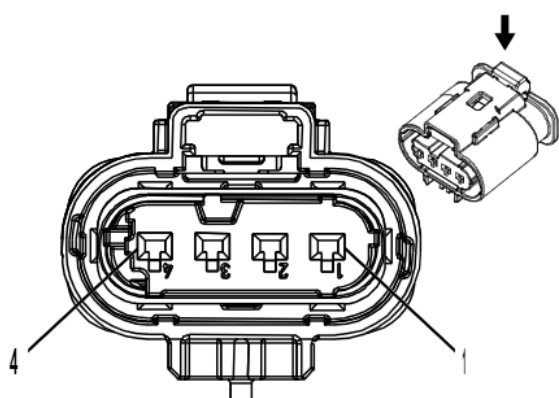

6709741

**Note:** It is recommended not to remove the terminals at the same time, but to replace one terminal at a time.

5. Using a terminal extractor, identify and remove the wire terminal 3.
6. Insert new jumper terminal into the electrical connector.
7. Using a terminal extractor, identify and remove the wire terminal 4.
8. Insert new jumper terminal into the electrical connector.
9. Cut the wire terminals away from the connector.
10. Fold over the wires and install heatshrink tubing over the old terminals.
  - ⇒ Utilizing Ultratorch J-38125-5 or equivalent, apply heat to the shrink tubing and seal the wires together.
11. Using Woven Polyester Electrical Tape (PET), tape the HO2S harness to the engine harness ensuring that the tape is applied in a double layer past the previously removed tape.
12. Reconnect the HO2S electrical connector.



6707537

13. Route the new harness along engine harness from HO2S sensor to the PCM.

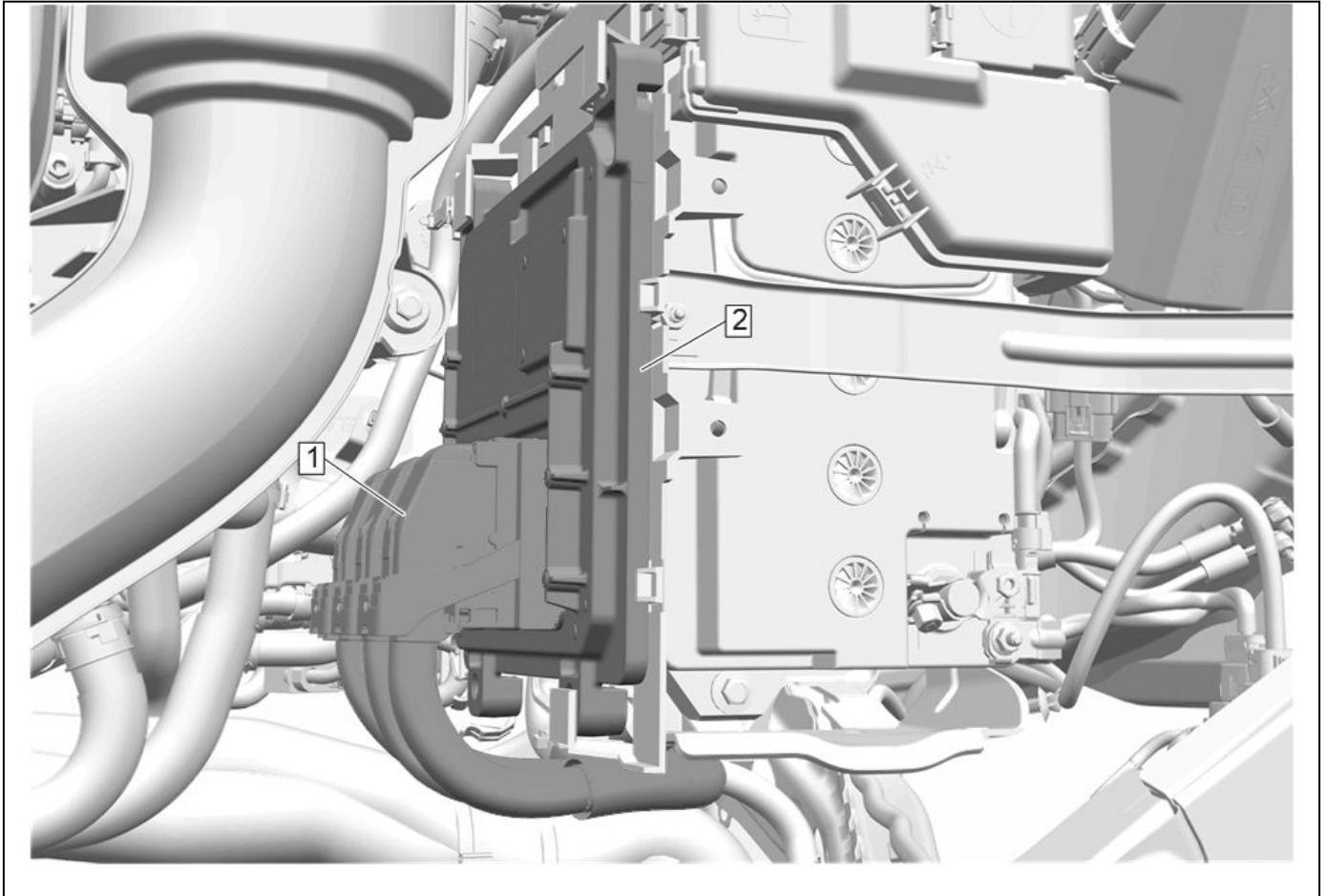

6380344

14. Remove the PCM (2). Refer to *Powertrain Control Module Replacement* in SI.
15. Remove the electrical connector terminal cover from the PCM X3 electrical connector.

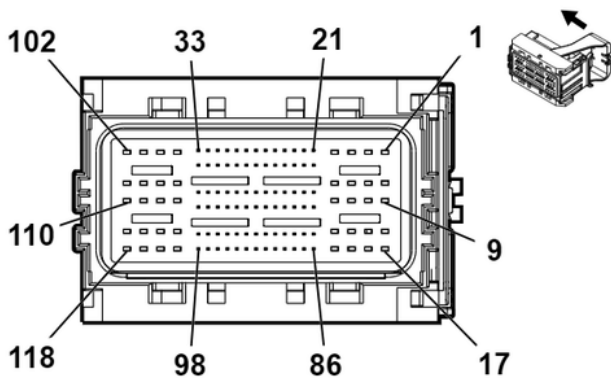

6709744

**Note:** It is recommended not to remove the terminals at the same time, but to replace one terminal at a time.

16. Using a terminal extractor, identify and remove the wire terminal 48 - HO2S Ground (BN).
17. Insert new jumper terminal into the electrical connector.

18. Using a terminal extractor, identify and remove the wire terminal 49 - HO2S Pump Current Signal (BN/WH).
19. Insert new jumper terminal into the electrical connector.
20. Cut the wire terminals away from the connector.
21. Fold over the wires and install heatshrink tubing over the old terminals.
  - ⇒ Utilizing Ultratorch J-38125-5 or equivalent, apply heat to the shrink tubing and seal the wires together.

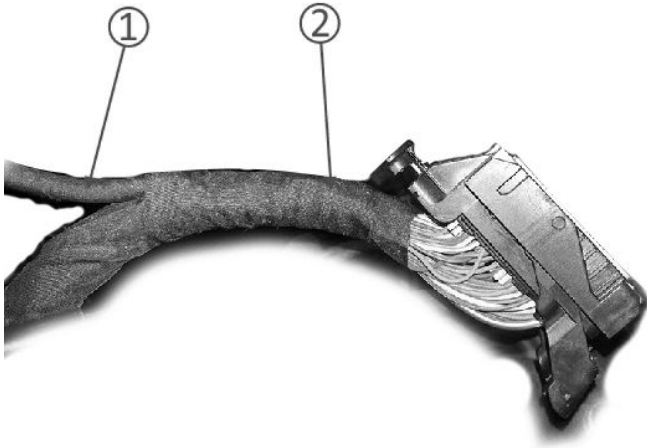

5089082

**Note:** When securing the HO2S harness, allow for some slack at the PCM to avoid possible binding at the PCM electrical connector.

22. Using Woven Polyester Electrical Tape (PET) (2), tape the HO2S harness (1) to the engine harness ensuring that the tape is applied in a double layer as shown in the **example** above.
23. Install the electrical connector terminal cover onto the electrical connector.
24. Install the PCM. Refer to *Powertrain Control Module Replacement* in SI.



6707537

**Note:** When routing the new harness, leave any additional slack at the PCM connector end.

25. Utilizing tie straps, secure the new HO2S harness to main engine wiring harness.

26. Install the Air Cleaner Outlet Duct. Refer to *Air Cleaner Outlet Duct Replacement* in SI.

27. Connect the negative battery cable.

### Parts Information

Causal Part	Description	Part Number	Qty
N/A	KIT, HO2S HARNESS	85808891	1
N/A	Woven Polyester (PET) Electrical Tape**	1985620 (USA)* 894.1230 (Canada)	As Required

\*There is enough material to service multiple vehicles. Store the remaining material for future use.

\*\*For USA, contact Wurth through website [www.wurthusa.com](http://www.wurthusa.com), by e-mail at [www.customer.service@wurthusa.com](mailto:www.customer.service@wurthusa.com), or by calling 1-800-987-8487.

For Canada, contact Wurth through their website at [www.wurth.ca/](http://www.wurth.ca/), by e-mail at [info@wurth.ca](mailto:info@wurth.ca), by calling 1-800-263-5002 or your local Wurth rep.

**Warranty Information**

For vehicles repaired under the Powertrain coverage, use the following labor operation. Reference the Applicable Warranties section of Investigate Vehicle History (IVH) for coverage information.

Labor Operation	Description	Labor Time
5486028*	HO2S Jumper Harness Installation	1.0 hr
*This is a unique Labor Operation for Bulletin use only.		

<b>Version</b>	3
<b>Modified</b>	Released August 01, 2024 Released August 13, 2024 - Added Important Statement in Parts Information section Revised October 16, 2024 - Removed TSP Number and Added New Harness Part Number.

