

GENERAL MOTORS  
DCS7080  
URGENT - DISTRIBUTE IMMEDIATELY

Date: November 19, 2024

Subject: N242470230 - Customer Satisfaction Program  
Owner's Manual Insert Update for Power Closure Key Fob Operation

Models: 2024-2025 Chevrolet Silverado EV  
2024-2025 GMC HUMMER EV Pickup  
2024-2025 GMC HUMMER EV SUV  
2024-2025 GMC Sierra EV

General Motors is releasing Customer Satisfaction Program N242470230 today.

What Should Dealers Do: Dealers should review IVH or the Dealer Maxis reports for open VINs in their inventory. Dealers can view the attached bulletin and it will also be displayed in Service Information tomorrow.

The Stock VIN list of vehicles in dealer inventory is attached to this message. Note: this list is only accurate at the time of report creation and all VINs should be validated in IVH prior to repair.

END OF MESSAGE

# Customer Satisfaction Program

## N242470230 Owner's Manual Insert Update for Power Closure Key Fob Operation



**Release Date:** November 2024

| Make      | Model            | Model Year |      |
|-----------|------------------|------------|------|
|           |                  | From       | To   |
| Chevrolet | Silverado EV     | 2024       | 2025 |
| GMC       | HUMMER EV Pickup | 2024       | 2025 |
| GMC       | HUMMER EV SUV    | 2024       | 2025 |
| GMC       | Sierra EV        | 2024       | 2025 |

Involved vehicles are marked "Open" on the Investigate Vehicle History screen in GM Global Warranty Management system. This site should always be checked to confirm vehicle involvement prior to beginning any required inspections and/or repairs.

|                   |   |
|-------------------|---|
| <b>Condition</b>  | Certain vehicles listed above may need an updated Owner's Manual insert which includes improved feature descriptions for Remote Key Operation (Key Fobs), Power Hood (eTrunk) for all, and Swing Gate information (for HUMMER EV SUV).  |
| <b>Correction</b> | Dealers will insert the updated insert into the Owner's Manual. Since the insert can be easily installed, and to reduce customer inconvenience, the insert will be sent directly to customers of record along with instructions. Customers may place the insert into their Owner's Manual or, if they desire, they may ask the dealer to perform this task. |

### Parts

No parts are required.

### Warranty Information

| Labor Operation | Description                             | Labor Time | Trans. Type | Net Item |
|-----------------|---|------------|-------------|----------|
| 9107684         | Print and Install Owner's Manual Insert | 0.1        | ZFAT        | N/A      |

### Service Procedure

1. Print the appropriate language owner manual insert(s) for your service area.
2. Locate the owner manual.
3. Install the owner manual inserts to the owner's manual.

# Customer Satisfaction Program

## N242470230 Owner's Manual Insert Update for Power Closure Key Fob Operation





### Insert to the 2024 and 2025 GMC Hummer EV Owner's Manuals

*This information replaces portions of the Remote Key Operation, Power Hood, and Swing Gate information found in the Keys, Doors, and Windows Section of the owner's manual.*

#### Remote Key Operation

 (Pickup Only) : Press twice to open the tailgate. The vehicle must be in P (Park). See Tailgate (Pickup Only).

 (SUV Only) : Press twice and hold the second time until the swing gate opens or closes. Releasing the button will stop the swing gate motion. The vehicle must be in P (Park). See Swing Gate (SUV Only).

 : Press twice to open the hood. To close the hood, press twice and hold the second time until the hood closes. Releasing the button will stop the hood motion. The vehicle must be in P (Park). See Hood.







Litho in U.S.A.  
Part No. 25GMCHUMINS1\_ENUS

#### Hood

##### Power Hood (eTrunk) Operation

###### Warning

You or others could be injured if caught in the path of the power hood. Always supervise the operation of the power hood until it is fully opened or closed and keep hands and other body parts away from the hood when in use.

- On the remote key, press  /  twice to open the hood. To close the hood, press  /  twice and hold the second time until the hood closes. Releasing the button will stop the hood motion. The vehicle must be in P (Park). See Remote Key Operation.

#### Swing Gate (SUV Only)

##### Swing Gate Operation

###### Warning

You or others could be injured if caught in the path of the gate. Always supervise the operation of the gate until it is fully opened or closed and keep hands and other body parts away from the gate when in use.

###### Warning

Do not drive the vehicle if the gate is not latched completely. The gate could open while the vehicle is in motion causing vehicle damage or personal injury. Before driving, close the gate and make sure the latch engages.

If equipped, the vehicle must be in P (Park) to operate the swing gate. The swing gate is disabled when a trailer is attached to the vehicle.

©2024 General Motors LLC. All Rights Reserved.

# Customer Satisfaction Program

## N242470230 Owner's Manual Insert Update for Power Closure Key Fob Operation



### 2

If the spare tire is removed or replaced with a tire of different weight, opening and closing operation may be inconsistent and require manual assistance.

When the swing gate is not latched, a message will display on the Driver Information Center.

To assist in opening, pull outwards on the spare tire or spare tire carrier directly after pressing .

To assist in closing, push the swing gate until the power closing latch engages.

#### Opening and Closing the Swing Gate using the Internal Button

To open or close the swing gate, press and hold the swing gate button on the instrument panel to the left of the steering wheel.

#### Opening and Closing the Swing Gate using the Remote Key

Press  twice and hold the second time until the swing gate opens or closes. Releasing the button will stop the swing gate motion. See Remote Key Operation.

If the swing gate is left in the open position for an extended period of time, it will need to be manually closed to regain remote functionality.

#### Opening and Closing the Swing Gate using the External Button

The remote key must be within 1 m (3 ft), when the doors are locked, to open the swing gate. If the doors are unlocked, the remote key is not required to open the swing gate.

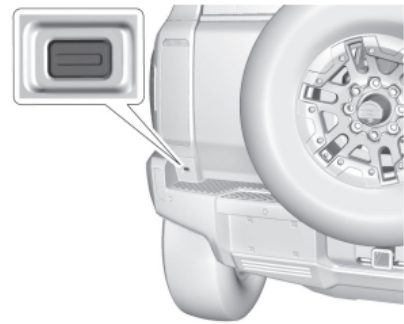

Press to open or close the swing gate with the external button.

# Customer Satisfaction Program

## N242470230 Owner's Manual Insert Update for Power Closure Key Fob Operation



### Insert to the 2024 and 2025 Chevrolet Silverado EV and GMC Sierra/Sierra Denali EV Owner's Manuals

*This information replaces portions of the Remote Key Operation and Power Hood information found in the Keys, Doors, and Windows Section of the owner's manual.*

#### Remote Key Operation

 : Press twice to open the tailgate. The vehicle must be in P (Park). See Tailgate.

 : Press twice to open the hood. To close the power hood (if equipped), press twice and hold the second time until the hood closes. Releasing the button will stop the hood motion. The vehicle must be in P (Park). See Hood.





Litho in U.S.A.  
Part No. 25MULSILSIEINS1\_ENUS

#### Power Hood (eTrunk) Operation (If Equipped)

##### Warning

You or others could be injured if caught in the path of the power hood. Always supervise the operation of the power hood until it is fully opened or closed and keep hands and other body parts away from the hood when in use.

- On the remote key, press  twice to open the power hood. To close the power hood, press  twice and hold the second time until the hood closes. Releasing the button will stop the hood motion. The vehicle must be in P (Park). See Remote Key Operation.

©2024 General Motors LLC. All Rights Reserved.

6760622

# Customer Satisfaction Program

## N242470230 Owner's Manual Insert Update for Power Closure Key Fob Operation





### Supplément au Guide du propriétaire du GMC Hummer EV 2024 et 2025

Cette information remplace les parties suivantes de la section *Clés, portes et glaces* du Guide du propriétaire : *Fonctionnement de la télécommande, Capot électrique et Portillon pivotant.*

#### Fonctionnement de la télécommande

 (camionnette uniquement) : Appuyer deux fois pour ouvrir le hayon. Le véhicule doit être en stationnement (P). Se reporter à Hayon (camionnette uniquement).

 (VUS uniquement) : Appuyer deux fois sur le bouton et le maintenir enfoncé la seconde fois jusqu'à ce que le portillon pivotant s'ouvre ou se ferme. Le fait de relâcher le bouton arrête le mouvement du portillon pivotant. Le véhicule doit être en stationnement (P). Se reporter à Portillon pivotant (VUS uniquement).

 /  : Appuyer deux fois pour ouvrir le capot. Pour fermer le capot, appuyer deux fois sur le bouton de capot en le maintenant



Imprimé aux États-Unis  
Numéro de pièce 25GMCHUMINS1\_FRCA





enfoncé la seconde fois jusqu'à la fermeture du capot. Le fait de relâcher le bouton arrête le mouvement du capot. Le véhicule doit être en stationnement (P). Voir Capot.

#### Capot

#### Fonctionnement du capot électrique (eTrunk)

##### Avertissement

Le conducteur ou d'autres personnes peuvent être blessés sur le chemin du capot électrique. Toujours superviser le fonctionnement du capot électrique jusqu'à ce qu'il soit complètement ouvert ou fermé et garder les mains et les autres parties du corps à l'écart du capot lorsqu'il est utilisé.

- Sur la télécommande, appuyer deux fois sur  /  pour ouvrir le capot. Pour fermer le capot, appuyer deux fois sur le bouton  /  en le maintenant enfoncé la seconde fois jusqu'à la fermeture du capot. Le fait de relâcher le

bouton arrête le mouvement du capot. Le véhicule doit être en stationnement (P). Se reporter à Fonctionnement de la télécommande.

#### Portillon pivotant (VUS uniquement)

#### Fonctionnement du portillon pivotant

##### Avertissement

Le conducteur ou d'autres personnes peuvent être blessés sur le chemin du portillon. Toujours superviser le fonctionnement du portillon jusqu'à ce qu'il soit complètement ouvert ou fermé et garder les mains et les autres parties du corps à l'écart du portillon lorsqu'il est utilisé.

##### Avertissement

Ne pas conduire le véhicule si le portillon n'est pas complètement verrouillé. Le portillon peut s'ouvrir lorsque le véhicule  
(Suite)

© 2024 General Motors LLC. Tous droits réservés.

6760579



2

### Avertissement (Suite)

est en mouvement et causer des dommages au véhicule ou des blessures. Avant de conduire, fermer le portillon et confirmer que la serrure s'enclenche.

Selon l'équipement, le véhicule doit être en position de stationnement (P) pour faire fonctionner le portillon pivotant. Le portillon pivotant est désactivé lorsqu'une remorque est attachée au véhicule.

Si la roue de secours est retirée ou remplacée par une roue de poids différent, l'ouverture et la fermeture peuvent être incohérentes et nécessiter une assistance manuelle.

Lorsque le portillon pivotant n'est pas verrouillé, un message s'affiche sur le centralisateur informatique de bord.

Pour faciliter l'ouverture, tirer vers l'extérieur sur la roue de secours ou sur le support de roue de secours directement après avoir appuyé sur .

Pour faciliter la fermeture, pousser le portillon pivotant jusqu'à ce que le loquet de fermeture électrique s'enclenche.

### Ouverture et fermeture du portillon pivotant à l'aide du bouton interne

Pour ouvrir ou fermer le portillon pivotant, appuyer longuement sur le bouton de portillon pivotant sur le tableau de bord à gauche du volant.

### Ouverture et fermeture du portillon pivotant à l'aide de la télécommande

Appuyer deux fois sur <sup>x2</sup> et le maintenir enfoncé la seconde fois jusqu'à ce que le portillon pivotant s'ouvre ou se ferme. Le fait de relâcher le bouton arrête le mouvement du portillon pivotant. Se reporter à Fonctionnement de la télécommande.

Si le portillon pivotant est laissé en position ouverte pendant une période prolongée, il doit être fermé manuellement pour réactiver les fonctions à distance.

### Ouverture et fermeture du portillon pivotant à l'aide du bouton externe

La télécommande doit se trouver à 1 m (3 pi) lorsque les portes sont verrouillées, pour ouvrir le portillon pivotant. Si les portes sont déverrouillées, la télécommande n'est pas nécessaire pour ouvrir le portillon pivotant.

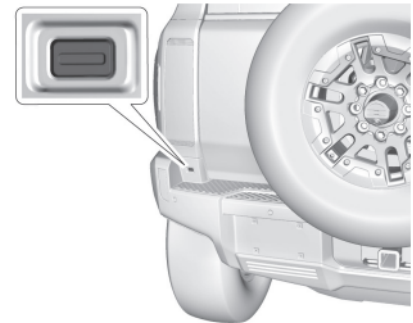

Appuyer sur le bouton externe pour ouvrir ou fermer le portillon pivotant.

6760581

# Customer Satisfaction Program

## N242470230 Owner's Manual Insert Update for Power Closure Key Fob Operation



### Supplément aux Guides du propriétaire des véhicules Chevrolet Silverado EV et GMC Sierra/Sierra Denali EV 2024 et 2025

*Cette information remplace les parties suivantes de la section Clés, portes et glaces du Guide du propriétaire : Fonctionnement de la télécommande et Capot électrique.*

#### Fonctionnement de la télécommande

 : Appuyer deux fois pour ouvrir le hayon. Le véhicule doit être en stationnement (P). Se reporter à Hayon.

 : Appuyer deux fois pour ouvrir le capot. Pour fermer le capot électrique (selon l'équipement), appuyer deux fois sur le bouton et le maintenir enfoncé la seconde fois jusqu'à ce que le capot se ferme. Le fait de relâcher le bouton arrête le mouvement du capot. Le véhicule doit être en stationnement (P). Se reporter à Capot.





Imprimé aux États-Unis  
Numéro de pièce 25MULSILSIEINS1\_FRCA

#### Fonctionnement du capot électrique (eTrunk) (selon l'équipement)

##### Avertissement

Le conducteur ou d'autres personnes peuvent être blessés sur le chemin du capot électrique. Toujours superviser le fonctionnement du capot électrique jusqu'à ce qu'il soit complètement ouvert ou fermé et garder les mains et les autres parties du corps à l'écart du capot lorsqu'il est utilisé.

- Sur la clé télécommande, appuyer deux fois sur  pour ouvrir le capot électrique. Pour fermer le capot électrique, appuyer deux fois sur le bouton  et le maintenir enfoncé la seconde fois jusqu'à ce que le capot se ferme. Le fait de relâcher le bouton arrête le mouvement du capot. Le véhicule doit être en stationnement (P). Se reporter à Fonctionnement de la télécommande.

©2024 General Motors LLC. Tous droits réservés.

6760623

# Customer Satisfaction Program

## N242470230 Owner's Manual Insert Update for Power Closure Key Fob Operation



ملحق لدليل مالك المركبة الكهربائية GMC Hummer للعامين ٢٠٢٤ و ٢٠٢٥

### Swing Gate (البوابة المفصليّة) (مركبة الدفع الرباعي الرياضية فقط)

تشغيل البوابة المفصليّة

#### تحذير ⚠

قد تتعرض أنت أو غيرك لإصابة إذا علقت في مسار البوابة. احرص دائمًا على مراقبة تشغيل البوابة إلى أن يتم فتحها أو إغلاقها بالكامل واحتفظ بيدك وأجزاء الجسم الأخرى بعيدًا عن البوابة عند استخدامها.

#### تحذير ⚠

لا تقود المركبة إذا لم يتم إغلاق البوابة بالكامل. يمكن أن تفتح البوابة في أثناء تحرك السيارة مما يتسبب في تلف السيارة أو الإصابة الشخصية. قبل القيادة، أغلق البوابة وتأكد من تعشيق المزلاج.



25GMCHUMINS1\_ARSA



حركة غطاء المحرك. ويجب أن تكون المركبة على الوضع P (الركن). راجع Hood (غطاء المحرك).

غطاء المحرك

### تشغيل غطاء المحرك الكهربائي (eTrunk)

#### تحذير ⚠

قد تتعرض أنت أو غيرك لإصابات إذا علقت في مسار غطاء المحرك. احرص دائمًا على مراقبة تشغيل غطاء المحرك الكهربائي إلى أن يتم فتحه أو إغلاقه بالكامل واحتفظ بيدك وأجزاء الجسم الأخرى بعيدًا عن غطاء المحرك عند استخدامه.

- في مفتاح التحكم عن بُعد، اضغط مرتين على  لفتح غطاء المحرك. لإغلاق غطاء المحرك، اضغط باستمرار ولمرتين على  إلى أن يتم إغلاق غطاء المحرك. سيؤدي تحرير الزرّ إلى إيقاف حركة غطاء المحرك. ويجب أن تكون المركبة على الوضع P (الركن). راجع Remote Key Operation (تشغيل مفتاح التحكم عن بُعد).

تحتل هذه المعلومات مكان أجزاء من المعلومات الخاصة بتشغيل مفتاح التحكم عن بُعد وغطاء المحرك الكهربائي والبوابة المفصليّة والموجودّة في قسم المفاتيح والأبواب والنواقد في دليل المالك.

تشغيل المفتاح عن بُعد

 (البك أب فقط) : اضغط مرتين لفتح باب صندوق الأمتعة. ويجب أن تكون المركبة على الوضع P (الركن). راجع Tailgate (باب صندوق الأمتعة) (البك أب فقط)

 (مركبة الدفع الرباعي الرياضية فقط) : اضغط باستمرار ولمرتين إلى أن يتم فتح أو إغلاق البوابة المفصليّة. سيؤدي تحرير الزرّ إلى إيقاف حركة البوابة المفصليّة. ويجب أن تكون المركبة على الوضع P (الركن). راجع Swing Gate (البوابة المفصليّة) (مركبة الدفع الرباعي الرياضية فقط).

 : اضغط مرتين لفتح غطاء المحرك. لإغلاق غطاء المحرك، اضغط باستمرار ولمرتين إلى أن يتم إغلاق غطاء المحرك. سيؤدي تحرير الزرّ إلى إيقاف

## Customer Satisfaction Program

### N242470230 Owner's Manual Insert Update for Power Closure Key Fob Operation



٢



اضغط على الزر الخارجي لفتح أو إغلاق البوابة المفصليّة.

فتح وإغلاق البوابة المفصليّة باستخدام مفتاح التحكم عن بُعد

اضغط باستمرار ولمرتين على زر [A] إلى أن يتم فتح أو إغلاق البوابة المفصليّة. سيؤدي تحرير الزر إلى إيقاف حركة البوابة المفصليّة. راجع Remote Key Operation (تشغيل مفتاح التحكم عن بُعد).

في حال تم ترك البوابة المفصليّة في وضعية الفتح لفترة زمنية طويلة، فستكون هناك حاجة لإغلاقها يدويًا من أجل استعادة وظائفها عن بُعد.

فتح وإغلاق البوابة المفصليّة باستخدام الزر الخارجي

يجب أن يكون مفتاح التحكم عن بُعد في نطاق ١ م (٣ أقدام)، عندما تكون الأبواب مغلقة، لفتح البوابة المفصليّة. في حالة إلغاء قفل الأبواب، لا يلزم توفر مفتاح التحكم عن بُعد لكي تتمكن من فتح البوابة المفصليّة.

في حال كانت مجهزة بذلك، يجب أن تكون المركبة في الوضع P (الركن) لتشغيل البوابة المفصليّة. يتم تعطيل البوابة المفصليّة عند توصيل مقطورة بالمركبة.

إذا تمت إزالة الإطار الاحتياطي أو تم استبداله بإطار ذي وزن مختلف، فقد تكون عملية فتح وإغلاق البوابة غير متنسقة وتتطلب مساعدة يدوية.

عندما لا تكون البوابة المفصليّة مغلقة بشكل آمن، سيتم عرض رسالة ذات صلة في مركز معلومات السائق.

للمساعدة في فتح البوابة، اسحب الإطار الاحتياطي أو حامل الإطار الاحتياطي نحو الخارج مباشرة بعد قيامك بالضغط على زر [A].

للمساعدة في الإغلاق، ادفع البوابة المفصليّة إلى أن يتم تحشيق مزلاج الإغلاق الكهربائي.

فتح وإغلاق البوابة المفصليّة باستخدام الزر الداخلي

لفتح أو إغلاق البوابة المفصليّة، اضغط باستمرار زر البوابة المفصليّة في لوحة العدادات، على يسار عجلة القيادة.

6760584

#### Dealer Responsibility

All new, used, GM Certified Pre-Owned (CPO), courtesy transportation vehicles, dealer shuttle vehicles, CarBravo, etc. in dealers' possession and subject to this field action must be held and inspected/repaired per the service procedure of this bulletin before customers take possession of these vehicles. Involved vehicles must be held and not delivered to customers, dealer-traded, released to auction, used for demonstration, or any other purpose.

All GM Certified Pre-Owned (CPO) vehicles currently in the dealers' inventory within the SHIFT Digital system will be de-certified and must be held and remedied per the service procedure in this bulletin. Upon submitting an accepted/paid warranty transaction in the Global Warranty Management (GWM) system, the vehicle can be re-certified for sale within the SHIFT Digital system, or once again be used in the Courtesy Transportation Program.

Dealers are to service all vehicles subject to this program at no charge to customers, regardless of mileage, age of vehicle, or ownership. Customers who have recently purchased vehicles sold from your vehicle inventory, and for which there is no customer information indicated on the involved vehicle listing, are to be contacted by the dealer. Arrangements are to be made to make the required correction according to the instructions contained in this bulletin. A copy of the customer letter is provided in this bulletin for your use in contacting customers. Program follow-up cards should not be used for this purpose, since the customer may not as yet have received the notification letter.

In summary, whenever a vehicle subject to this program enters your vehicle inventory or is in your facility for service, you must take the steps necessary to be sure the program correction has been made before selling or releasing the vehicle.

# Customer Satisfaction Program

## N242470230 Owner's Manual Insert Update for Power Closure Key Fob Operation



### Dealer Reports – For USA & Export

For dealers with involved vehicles, a listing has been prepared and will be available through GM Global Connect Maxis Field Action Reports or sent directly to export dealers. The Inventory tab of the dealer reports will contain VINs that apply to this field action. This information is intended to assist dealers with the **PROMPT COMPLETION** of these vehicles. The Customer In-Service tab will contain customer names and addresses from Motor Vehicle Registration Records. The use of such motor vehicle registration data for any purpose other than follow-up necessary to complete this field action may be a violation of law in several states.

### Customer Notification

USA & Canada - General Motors will notify customers of this program on their vehicle (see copy of sample customer letter included with this bulletin).

Export - Letters will be sent to known owners of record located within areas covered by the US National Traffic and Motor Vehicle Safety Act. For owners outside these areas, dealers should notify customers using the attached sample letter.

---

GM bulletins are intended for use by professional technicians, NOT a "do-it-yourselfer". They are written to inform these technicians of conditions that may occur on some vehicles, or to provide information that could assist in the proper service of a vehicle. Properly trained technicians have the tools, equipment, safety instructions, and know-how to do a job properly and safely. If a condition is described, **DO NOT** assume that the bulletin applies to your vehicle, or that your vehicle will have that condition. See your dealer for information on whether your vehicle may benefit from the information.



**We Support  
Voluntary Technician  
Certification**

# Customer Satisfaction Program

## N242470230 Owner's Manual Insert Update for Power Closure Key Fob Operation



This notice applies to your vehicle, **VIN:** \_\_\_\_\_

Dear General Motors Customer:

To improve your ownership experience, we want to make sure you understand every feature of your vehicle. Enclosed is an updated Owner's Manual insert which includes improved feature descriptions for:

- Remote Key Operation (Key Fobs)
- Power Hood (eTrunk), and Swing Gate information.

You can also explore helpful video(s) for a detailed walk through of these features using the QR code(s) below.

**What We Will Do:** If you lose this insert or have questions, please reach out to your preferred dealer. Your dealer can also print and place this insert in your Owner's Manual.

**What You Should Do:** Keep the insert in your vehicle for future reference and scan the QR code(s) below for a detailed walk through of these features.

If you have any questions or concerns that your dealer is unable to resolve, please contact the appropriate Customer Assistance Center at the number listed below.

For the hearing or speech impaired, please contact our Customer Assistance Center using the Telecommunication Relay Service by dialing 711 then providing the appropriate Customer Assistance Center number for your vehicle.

| Division               | Number                              |
|------------------------|-------------------------------------|
| Chevrolet Silverado EV | 1-833-EVCHEVY<br>(1-833-382-4389)   |
| GMC                    | 1-800-462-8782                      |
| GMC HUMMER EV/SUV      | 1-833-HUMMER-EV<br>(1-833-486-6373) |
| Puerto Rico – English  | 1-866-467-9700                      |
| Puerto Rico – Español  | 1-866-467-9700                      |
| Virgin Islands         | 1-866-467-9700                      |

We truly appreciate you taking the time to review the updates to your Owner's Manual as we know your time is valuable. We want you to know that we will do our best, throughout your ownership experience, to ensure that your vehicle provides you with many miles of enjoyable driving.

<O'Connor\_closing>

Enclosure  
N242470230