



**PROTERRA**



# TECHNICAL SERVICE BULLETIN

<b>ISSUE DATE:</b>	10-27-2022
<b>SERVICE BULLETIN SUBJECT:</b>	Duopower Motor Replacement
<b>VINs or MODELS AFFECTED:</b>	Service Specified Buses
<b>COMPLETE BY:</b>	Next Service Opportunity
<b>SERVICE BULLETIN #:</b>	SC-22-134
<b>LABOR OPERATION CODE:</b>	PP50Z

**NOTICE! It is expected that this process will require eight hours per bus. Please schedule appropriately to minimize vehicle downtime.**

## **CURB SIDE DUOPOWER MOTOR REPLACEMENT**

### **Description:**

This procedure describes the process of replacing defective Curb Side Duopower Motors.

## Tools/Parts Required:

- Customer Service Laptop with Proterra Diagnostic Tool
- Nexiq USB Link2 or USB Link 2
- Wheel Lifts (4 EA)
- Jack Stands (4 EA)
- Catch Pan
- Orange Torque Stripe Paint
- Lift Table
- Ratchet
- 9/16-Inch Socket
- 7/8-Inch Socket
- 27mm Socket
- 19mm Socket
- 10mm Socket
- Calibrated Torque Wrench
- 50/50 Ethelene Glycol Coolant
- Side Cutting Pliers

## Kit Parts Required:

- 063007 Service Retrofit Kit, Motor Replacement, Duopower (Consisting of)
  - 040924 MOTOR, GVM 310-125 1 EA

## Procedure:

1. Use the Proterra approved Lockout/Tagout procedure to make the bus safe for work.
2. Using the four Wheel Lifts, safely lift the bus.
3. Using the four Jack Stands, support the bus at the lifting points.
4. Follow the procedure in the Maintenance and Repair Manual to remove and replace the Duopower Axle and to replace the defective Curb Side Motor **(040924)**. This procedure begins on page 11-196 of the manual. The Duopower Drive Train chapter from the manual is attached to this document.
5. Once the Curb Side Motor is replaced, remove the Jack Stands and lower the bus using the Wheel Lifts.
6. Remove the Lockout/Tagout devices and power the bus on.
7. Follow the procedure that begins on page 213 of the Maintenance and Repair manual to pair the Motors (040924) to the Inverter.
8. Return the bus to service.

## Chapter 11: DuoPower Drive Train (Rear Axle)

### Overview

The DuoPower drive train system employs state-of-the-art electric vehicle technology that integrates the powertrain components (traction motor and gearbox) into the rear axle. The DuoPower drive train uses two permanent-magnet synchronous 205 kW traction motors, each directly coupled to a two-speed gearbox that independently drives its respective set of wheels. The system is capable of up to 550 peak horsepower and is controlled via an inverter which receives direct current from the high-voltage battery system.

The drive train power electronic components (traction motors and inverter) use a liquid cooling circuit to reject heat through the bus heat exchanger. The two gearboxes use a twin loop oil pump module that filters, cools, and pumps the gearbox oil through each gearbox individually. Each oil loop inside the oil pump module contains an electric oil pump, sump screen filter, pressure-side bypass filter and heat exchanger.

The two electric traction motors are controlled using a dual inverter. The motor and controller combination is a powerful, lightweight, rugged and reliable package that is specifically designed for high performance drive applications. The two-speed gearboxes are purpose designed and built for heavy duty electric vehicle operation. The gearboxes contain a pneumatically actuated shift mechanism to seamlessly shift between low and high gear. The output of the gearboxes is coupled to a planetary gear reduction unit housed within the wheel ends.

The rear axle cradle assembly supports the wheel ends and includes disc brakes, suspension arms, quad-link control arms, and all components needed for suspension, springs and damping, including the ABS/ASR and brake wear sensors.

### DuoPower Axle Tools List

To properly maintain a DuoPower Axle, the following special tools are required:

Proterra PN	ITEM/TOOL NAME	USED FOR
051136	20M x 1.5, Drain, Wheel End, Duo Power	Wheel End Fluid Drain Plug
050900	KIT, OIL HAND PUMP, GEAR BOX, DUO POWER, SPECIAL TOOL (Includes 050897, 050898 & 050899)	Gear Box Fluid Changes
050897	5 LITER, PLASTIC, DRUM, OIL, OIL SAFE	
050898	UTILITY LID, YELLOW, OIL HAND PUMP, OIL SAFE	
050899	PREMIUM HAND PUMP, HANDLE, YELLOW, OIL SAFE	
051261	24MM CROW'S FOOT, 3/4" DRIVE, SPECIAL TOOL, DUO POWER (Dog Bone)	Brake Component Removal and Replacement
116-6487	TOOL, SOCKET, AXIAL LOCK NUT	Axial Lock Nut Removal and Replacement
120-7746	TOOL, WHEELEND, AXIAL NUT TMFS 5, 38MM	Axial Lock Nut Removal and Replacement
120-7747	TOOL, WHEELEND, AXIAL NUT TMFS 7, 52MM	Axial Lock Nut Removal and Replacement
120-5847	TOOL, WHEELEND, SPINDLE NUT, DUO POWER	Spindle Nut Removal and Replacement
128-2242	TOOL, OFFSET ADAPTER, 1/2" DRIVE	Lock Nut / Spindle Removal and Replacement
COTS	Bearing Puller	Lock Nut / Spindle Removal and Replacement
COTS	Motion Pro Tool	Lock Nut / Spindle Removal and Replacement

## Drive Train Diagram

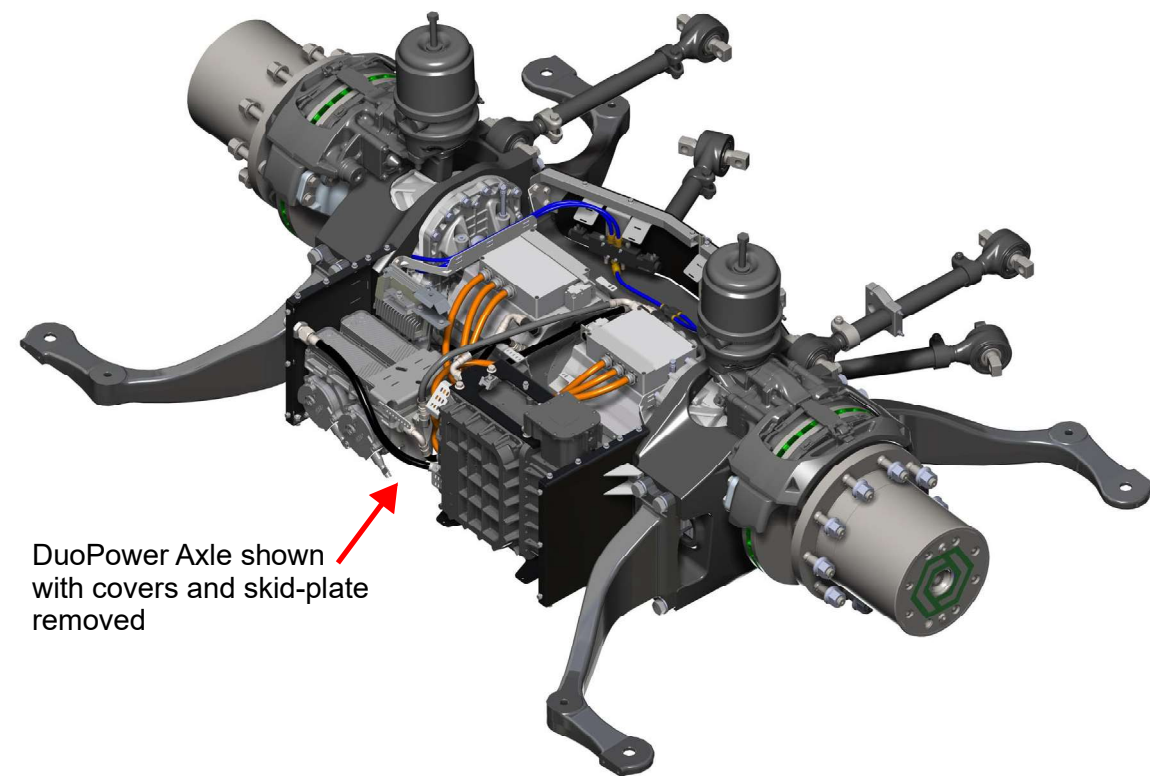
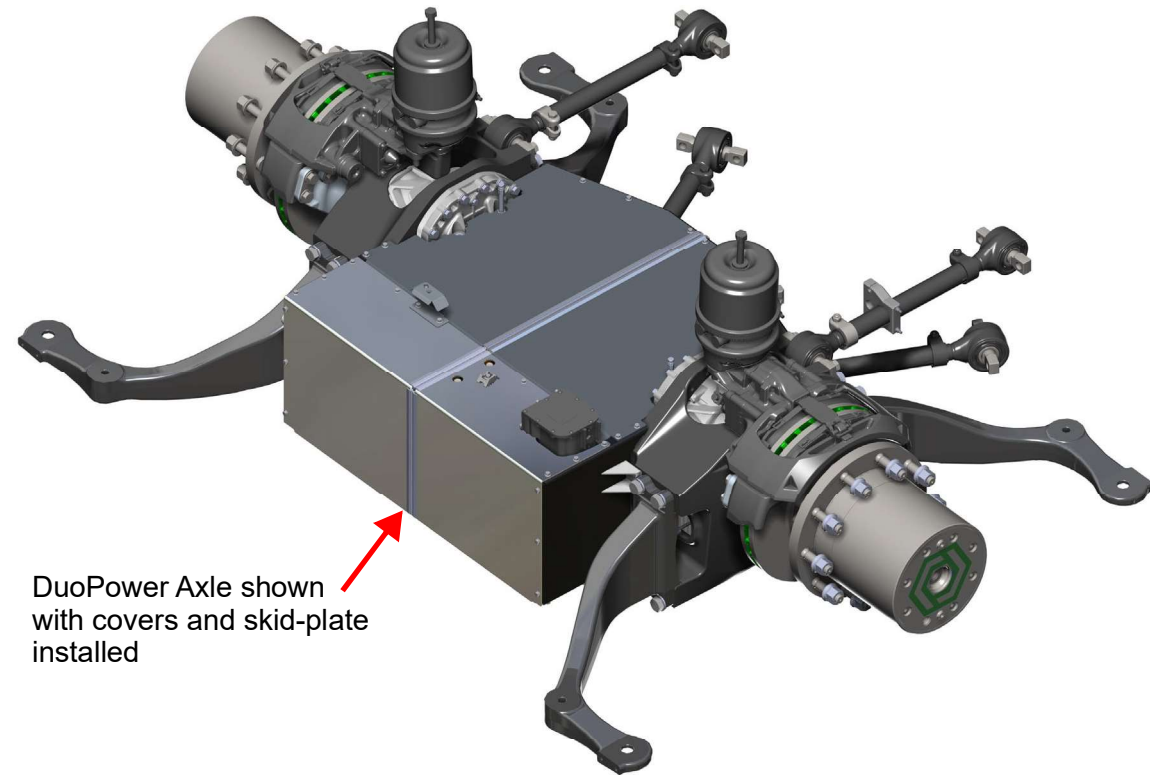


Figure 11-1. DuoPower Axle (with and without covers)

## DuoPower Axle Component Identification

The following figures provide exploded view component identification and top/bottom views of the DuoPower axle assembly.

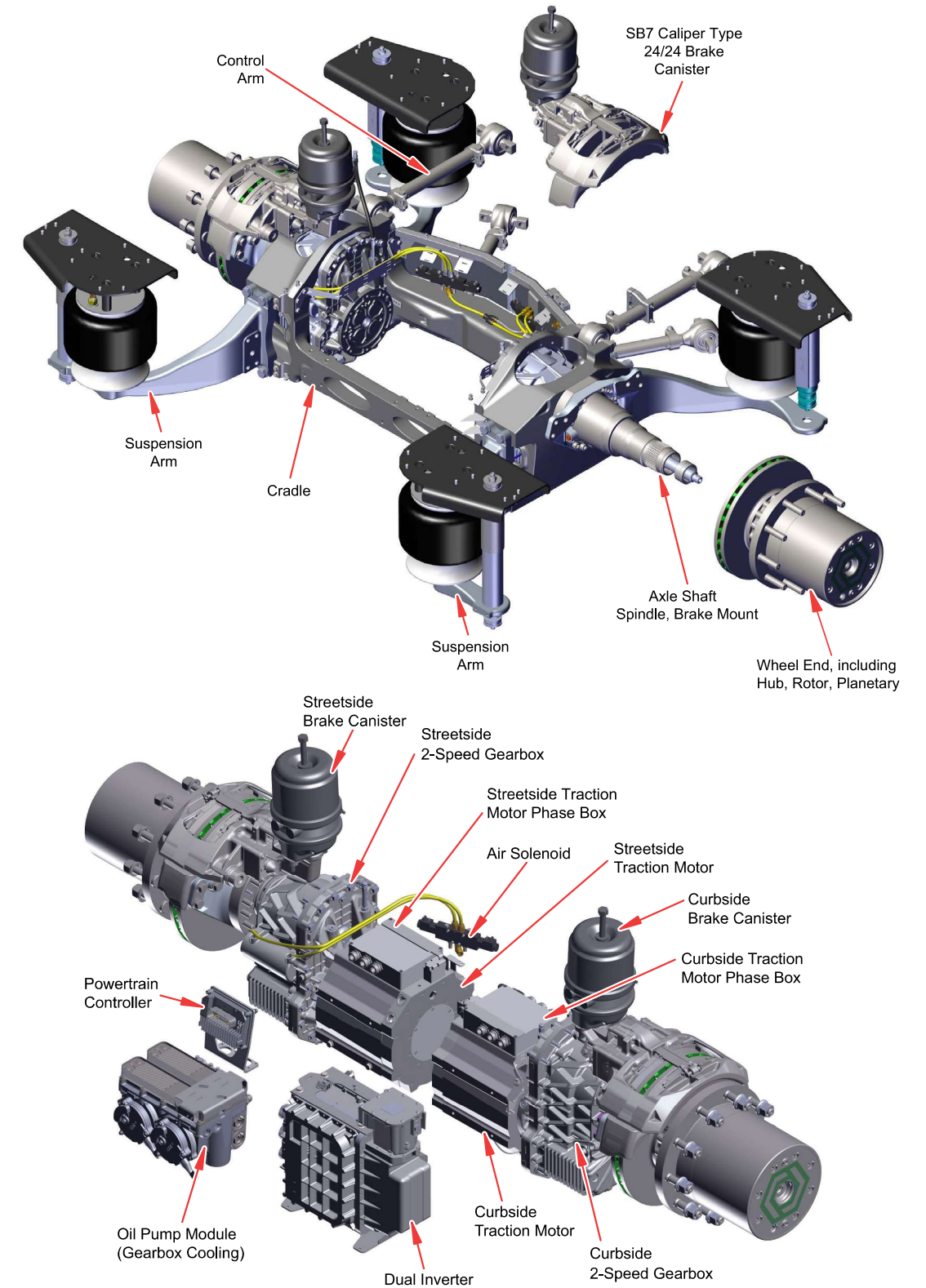


Figure 11-2. DuoPower Axle Component Identification

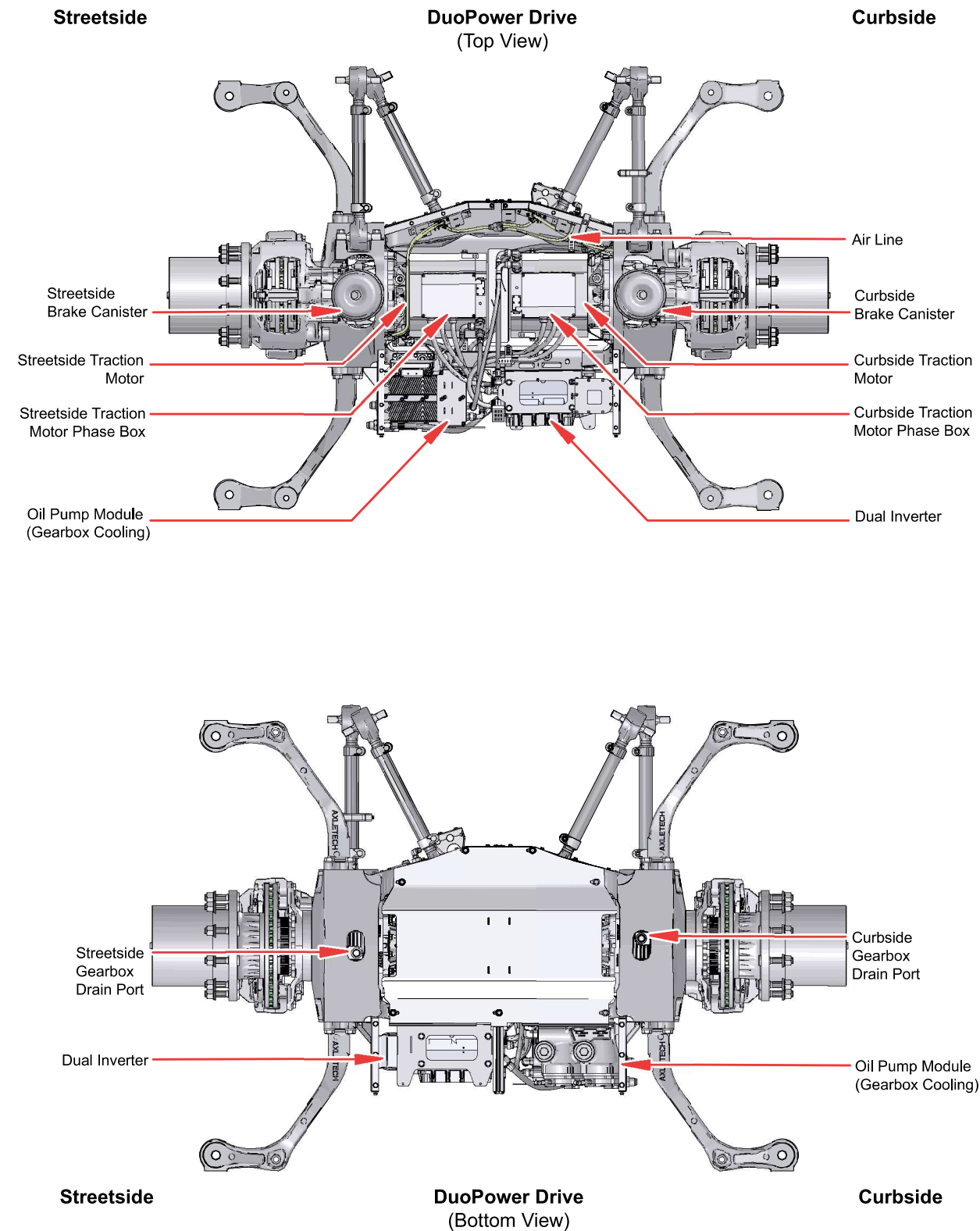


Figure 11-3. DuoPower Axle (Top and Bottom View)

## Traction Motors and Controller

The main traction motors, or propulsion motors, are a AC, permanent-magnet, water cooled type. The traction motors provide the drive power to move the bus. This type of motor is well suited to this application as it generates considerable power and torque in a small, lightweight, durable package.

The traction motors are connected to the dual inverter with three-phase, high-voltage AC power cables and a data cable. The dual inverter utilizes solid state electronics to convert high-voltage DC from the main batteries into variable frequency, variable current, three-phase AC power to turn the traction motor at the desired speed and power level. The dual inverter is water cooled and contains no moving parts.

Driver commands from the accelerator pedal and other inputs are read by the powertrain controller which in turn sends commands to the dual inverter. The dual inverter then generates the required output power to drive the traction motors as desired.

Power flow through the dual inverter is bidirectional. When acceleration is commanded, power flows from the main battery pack to the inverter and then to the traction motors. When deceleration, or regenerative braking, is commanded the power flow is reversed. The traction motors generate electricity which flows to the inverter, gets converted to DC, and then recharges the main battery. Regenerative braking results in a significant improvement in vehicle energy efficiency.

The powertrain controller communicates to the inverter via CAN. The system includes a significant amount of safety controls and diagnostics that activate when faults are detected.

## Regenerative Braking

The Proterra bus utilizes two main systems to slow down or decelerate the vehicle, a standard pneumatic friction brake system and regenerative braking. Regenerative braking uses the traction motors to generate electricity which slows the vehicle. The ability to capture energy while braking results in a large improvement in energy efficiency of the vehicle. On a traditional vehicle, the energy created during braking is lost to heat through the friction brakes or the retarder.

When the driver lifts off the accelerator pedal (zero pedal) up to 50% of available regenerative braking torque is automatically applied. The remaining 50% of available regenerative braking is then applied linearly when the driver begins to press on the brake pedal. The pneumatic brakes begin to work linearly with increased brake pedal travel. The feel of the regenerative braking system is similar to a traditional retarder.

Regenerative braking is reduced below 3 mph to make low speed bus movement smoother. In the event of an ABS or Traction Control event, regenerative braking is automatically disabled until the vehicle comes to a complete stop. It is automatically re-enabled upon continuation. This is done to ensure vehicle stability in slippery conditions.

The Proterra regenerative-braking system will enable an efficient driver to drive almost entirely without the brake pedal. Drivers that anticipate stops and allow regenerative braking to slow the vehicle for maximum energy recapture maximize efficiency.

## Powertrain Technical Specifications

**Table 11-1: Traction Motor Technical Specifications - For Single Motor**

Parameter	Specification
Peak Power	*205 kW (275 hp)
Continuous Power	*126 kW (169 hp)
Peak Torque	*450 Nm (332 ft-lb)
Continuous Torque	*360 Nm (265 ft-lb)
Operating Voltage	450 to 750 VDC
Max Operating Speed	*8500 RPM
Weight	176 lb (80 kg) without phase leads

\* DuoPower application specific capability

**Table 11-2: Dual Inverter Technical Specifications**

Parameter	Specification
Continuous Output Power Rating	280kVA (Maximum)
Continuous Output Current Rating	400 ARMS (Maximum)
Peak Output Current Rating	600 ARMS (Maximum)
High-Voltage Bus Normal Operating Range	180VDC (Minimum), 700VDC(Nominal), 750VDC (Maximum)
Output Voltage	0 to 480 VRMS
Weight	59.5 lb (27 kg)
Enclosure Rating	IP67, IP6K9K

**Table 11-3: Gearbox Technical Specifications**

Parameter	Specification
Speeds and Gear Position Sensor	L - Low, H - High, N - Neutral
Shifting	Pneumatically Actuated
Max output speed	1950 RPM (vehicle speed limit)
Sensors	Output Speed Sensor, Shifter Position Sensor, Oil Sump Temperature Sensor
Oil Capacity	5 Quarts (4.8 liters)
Gear Ratios	Low - 7.777:1, High - 4.375:1
Overall Dimensions	334mm Long, 465mm High, 331mm Wide
Weight	____ lb (____) kg (without oil)

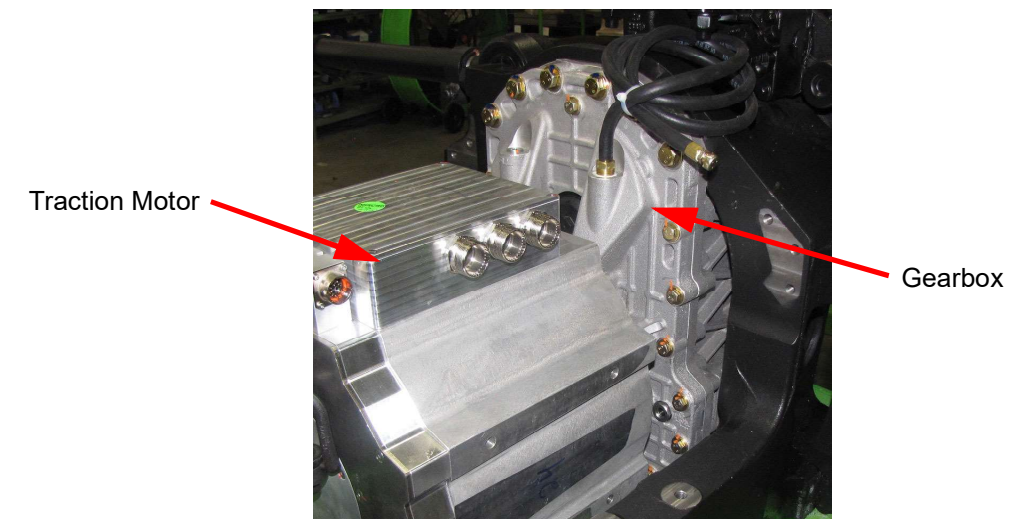
## Gearboxes

The Proterra two-speed gearboxes are purpose designed and built for heavy duty electric vehicle operation. The gear ratios were selected to maximize fuel economy for transit bus operation while ensuring best in class performance. The gearboxes contain a pneumatically actuated shift mechanism to seamlessly shift between low and high gear. The output of the gearboxes is coupled to a planetary gear reduction unit housed within the wheel ends.

All actuators and sensors for the gearboxes are connected to the Proterra DuoPower controller which is responsible for shift actuation and motor torque commands. The controls have been optimized to balance drive feel while maximizing efficiency.

The vehicle control system was designed using Proterra's state-of-the-art computer simulation model and calibrated with real-world data from customer vehicles, engineering testing utilizing proprietary drive cycles and standard FTA drive cycles (CBD, Arterial, Commuter).

With the two-speed gearboxes Proterra can utilize smaller, lighter weight traction motors to achieve best in class acceleration and gradeability performance. The gearboxes also allow the drivetrain system the flexibility of operating at more efficient motor operating points, thus improving overall vehicle efficiency.



**Figure 11-4. Location of Gearbox in Cradle**

### Gear ratios:

- 1st gear = 7.777:1
- 2nd gear = 4.375:1

The gearbox utilizes the following sensors for control and diagnostics:

- Gear Position sensor (Hall Effect)
- Output Speed Sensor
- Oil Sump Temperature Sensor

Diagnostics monitor the performance of all the elements and sensors and will set faults in the event a problem is detected.

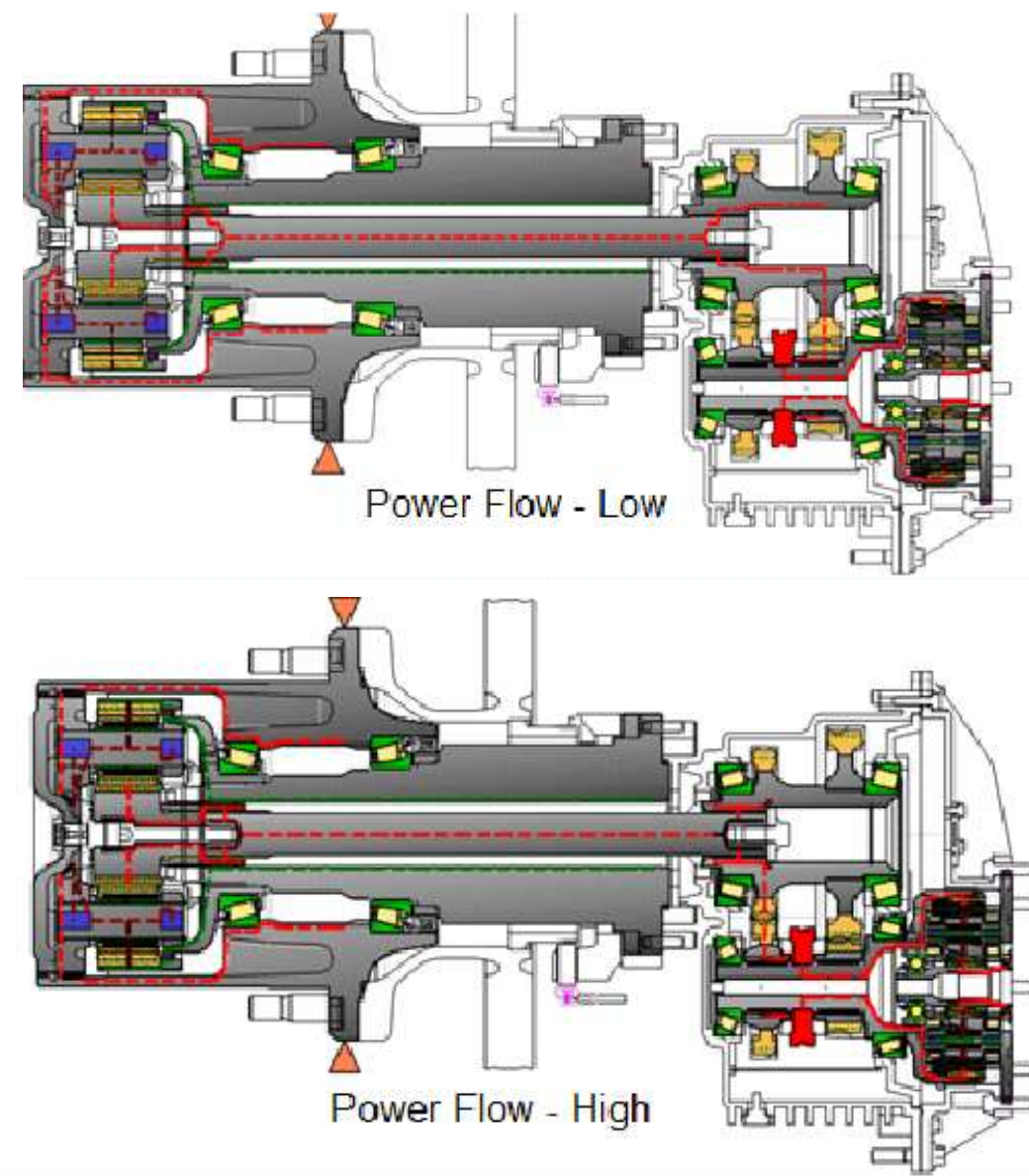
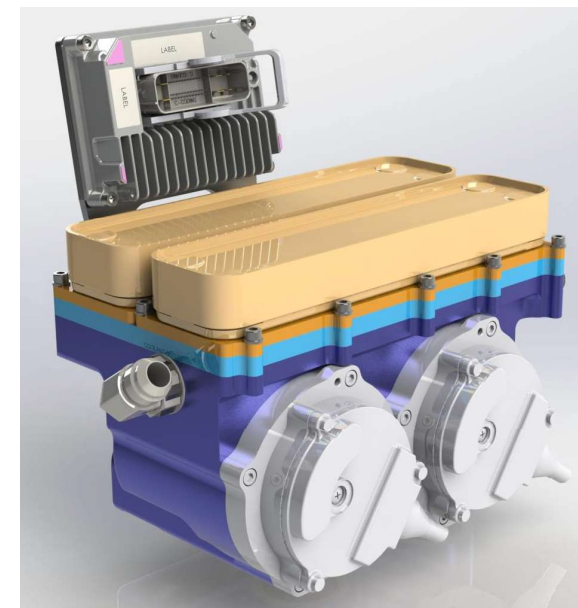


Figure 11-5. Gearbox Power Flow

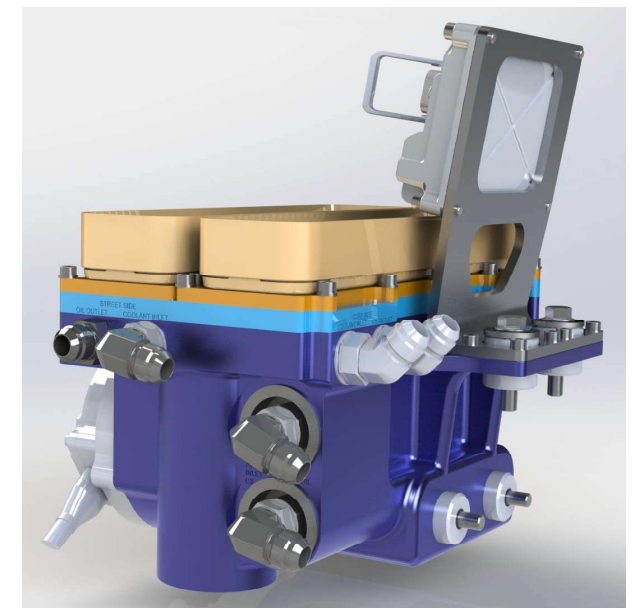
## Oil Pump Module

The oil pump module is custom designed to filter, cool, and pump oil through each of the two gearboxes. The oil pump module has two independent channels, each with an electric oil pump, sump screen filter, pressure-side bypass filter, and heat exchanger.

The oil loops each have an independent inlet and outlet for the curbside and streetside gearboxes. The coolant has two individual inlets for curbside and streetside, but both coolant paths join into a single discharge path at the outlet.



Oil Pump Module (Front/Left View)



Oil Pump Module (Rear/Right View)

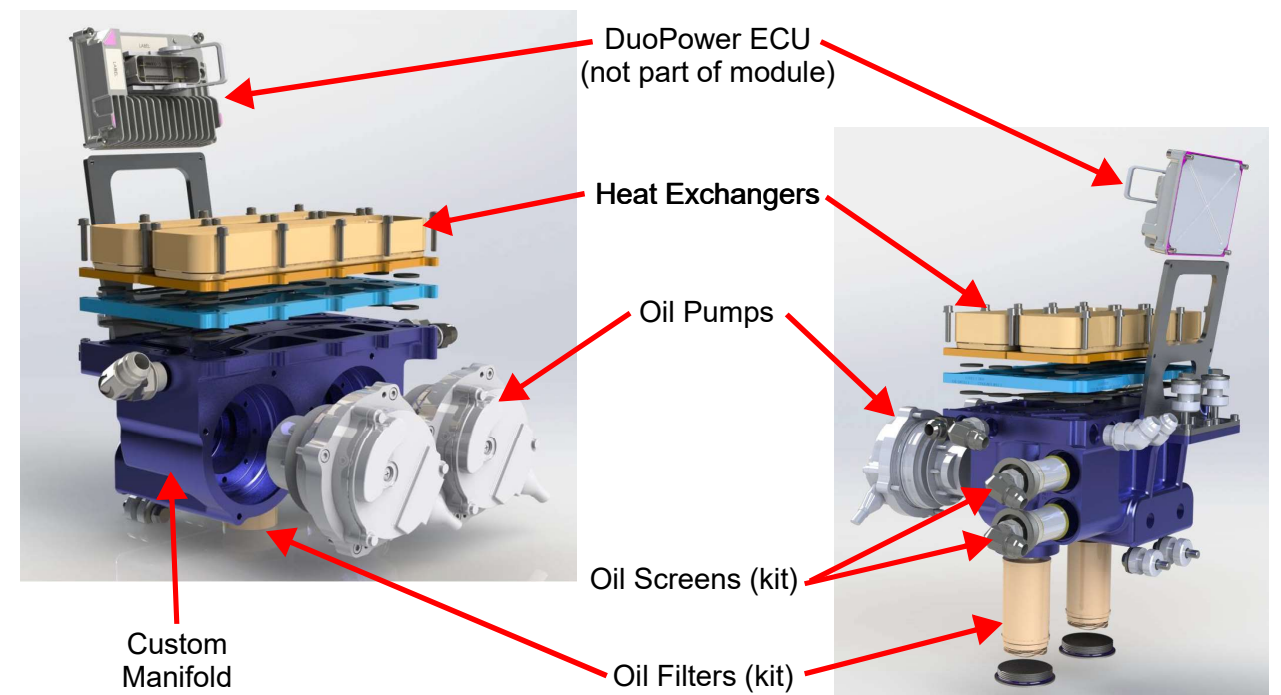


Figure 11-6. Oil Pump Module Component Identification Views

## DuoPower Drive Train Preventive Maintenance

The following provides a detailed preventive maintenance schedule and procedures on how to perform the preventive maintenance tasks for the DuoPower Drive Train assemblies and components.

### Wheel End Maintenance

The Wheel Ends on the DuoPower Drive Train require the following maintenance at regular service intervals.

- Break-in fluid change after first 6,000 Miles (9,656 Km)
- Regular fluid changes every 25,000 Miles (40,234 Km)
- Capacities: 3 Qts (2.8 Liters) per Wheel End  
**(NOTICE: Fill the wheel end until the oil flows out of the center hole)**
- Lubricant: US Lube SAE 80W90 Non-Synthetic Gear Oil (Must meet GL5, MT-1 Standards)
- Alternate Synthetic Lubricant: 75W-90 (synthetic) (Must meet GL5, MT-1 Standards)

**NOTICE!** Canadian customers can use SAE 80W90 API GL-5 MT-1 manufactured by Petro-Canada.

### Gearbox Maintenance

The Gearboxes on the DuoPower Drive Train require the following maintenance at regular service intervals.

- Regular fluid changes every 100,000 Miles (160,934 Km)
- Capacities: 5 Qts (4.8 Liters) per Gearbox
- Lubricant Type: BASF Emgard MTF 7000 Synthetic Transmission Fluid or Shell Spirax S6 GME 40 (alternative brand to BASF)

**NOTICE!** Canadian customers can use TRAXON E Synthetic MTF (Synthetic Transmission Fluid) manufactured by Petro-Canada in the gearbox.

### Oil Pump Module Maintenance

The Oil Pump Module on the DuoPower Drive Train requires the following maintenance at regular service intervals.

- Replace Inlet Oil Filter every 100,000 Miles (160,934 Km)
- Replace Outlet Oil Filter every 100,000 Miles (160,934 Km)

**IMPORTANT!** As an integral part of the gearbox oil change process, you must replace the oil filters in the oil pump module in addition to the oil in the gearboxes.

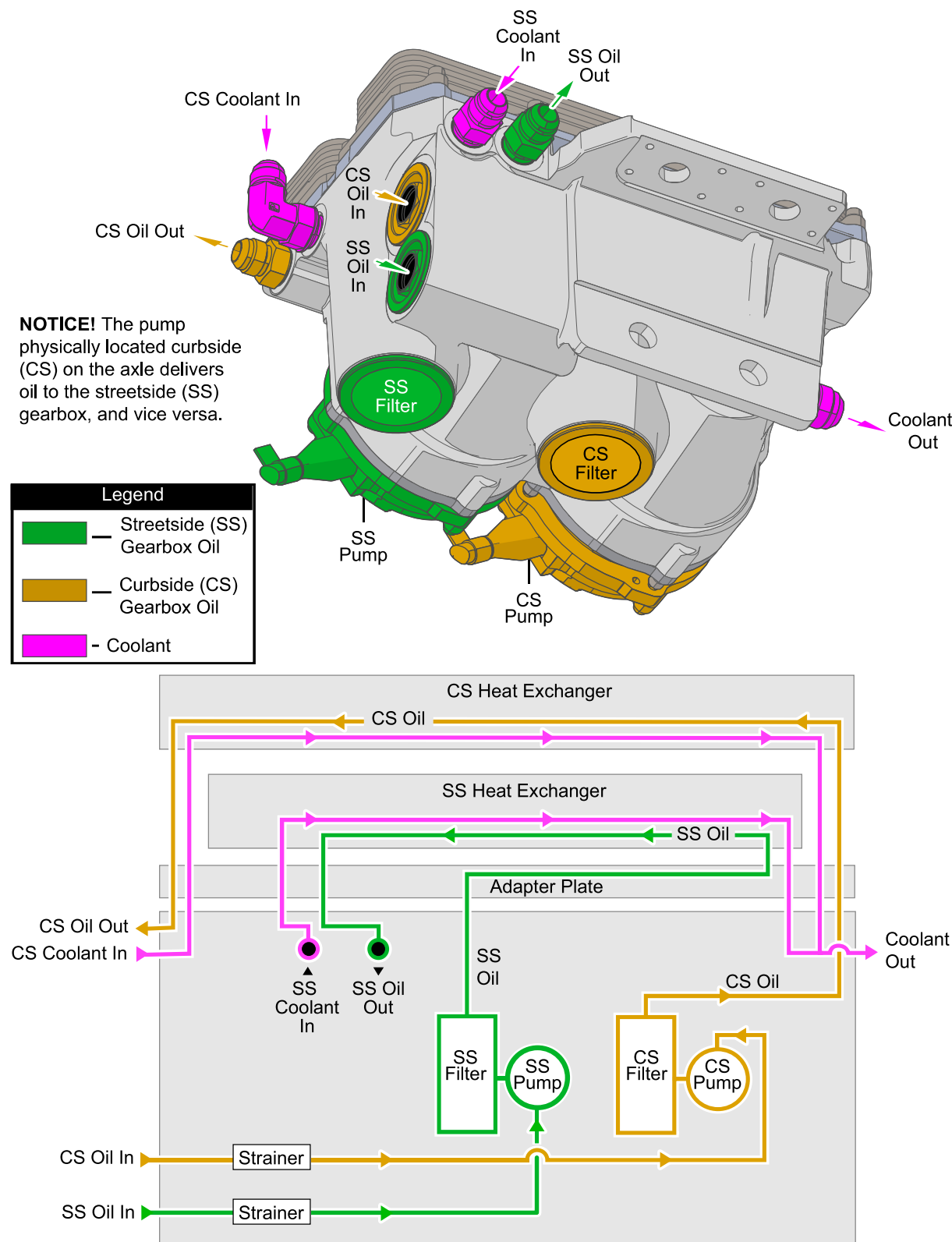


Figure 11-7. Oil Pump Module Flow Diagram

**NOTE:** The oil pump physically located curbside in the Oil Pump Module delivers oil to the streetside gearbox, and streetside located pump delivers oil to the curbside gearbox.

## Visual Inspection

The following visual inspections of the DuoPower Drive Train should be performed at regular service intervals.

- Check for loose fasteners on cover panels, tighten as needed.
- Check Gearboxes for signs of oil leakage
- Check Wheel Ends for signs of oil leakage
- Check for signs of leakage at each coolant connection on the exterior of the DuoPower Axle
- Check for signs of coolant leakage behind the cover plates of the DuoPower Axle
- Check for signs of chafing of air lines, coolant hoses, and electrical harnesses/cables

## Drain and Fill Wheel End Fluid

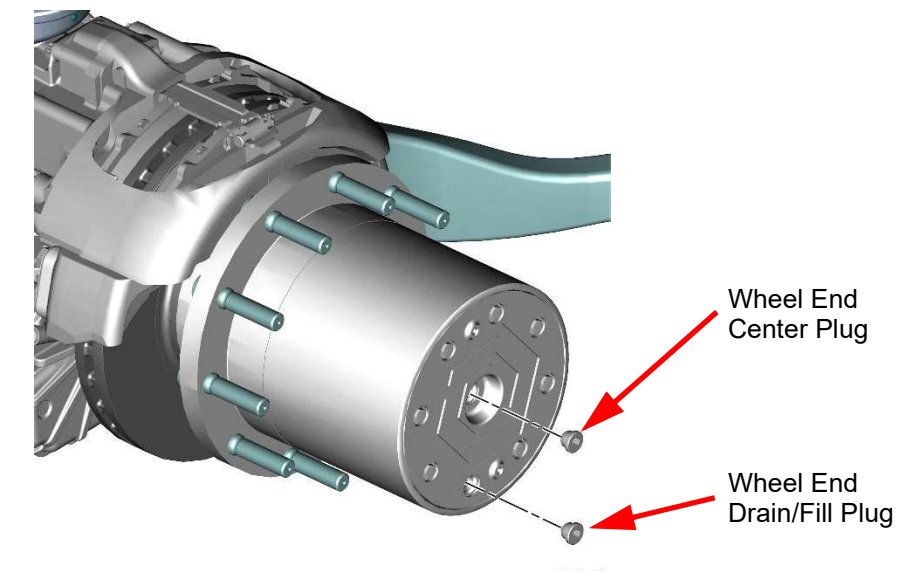
After approximately 6,000 miles (9,656 Km) of service the wheel ends will require a break-in fluid change. After this initial break-in change, service the wheel ends every 25,000 miles (40,234 Km). The fluid should be drained and refilled with fresh, clean, approved 80W90 Gear Oil. To change the wheel end fluid, perform the following:

**IMPORTANT!** Read all instructions and know what must be performed prior to starting this procedure! Failure to use extremely clean fluid change techniques can adversely affect the reliability of the wheel ends.

1. Drive for approximately 5 miles to bring the vehicle up to operating temperature and to adequately stir up the fluid in the wheel ends.
 

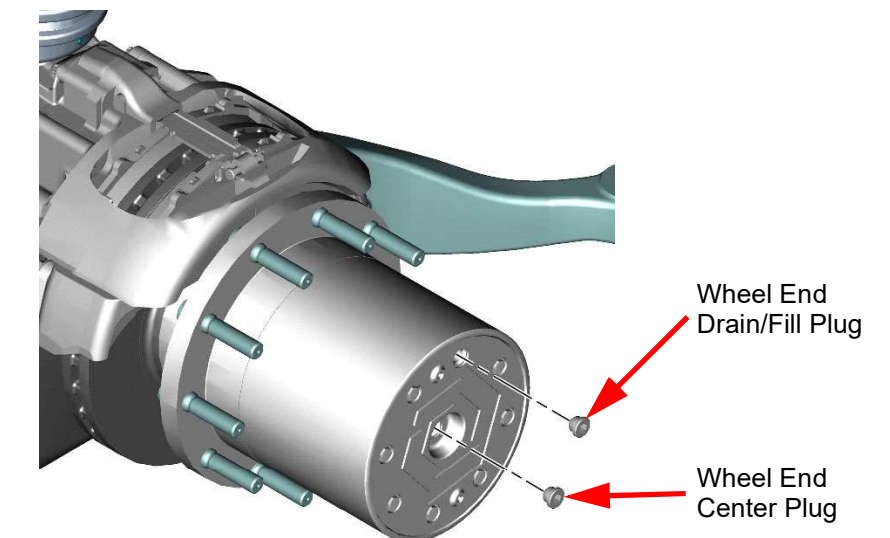
**Note:** You must be prepared to drain the fluid immediately after shutdown, when the fluid is still at normal operating temperature.
2. Park the bus in the designated service location in position to access the wheel end drain plugs and record the specific bus receiving the wheel end fluid change and the bus mileage shown on the odometer.
3. Thoroughly clean the area around the drain plug and center plug.
4. Chock the wheels, release the parking brake, and then raise the vehicle to allow the wheel ends to be rotated.
5. Rotate the wheel end until the outer drain/fill plug is at the 6 o'clock (vertically down) position.
6. Place a suitable catch pan capable of holding 3 quarts of fluid below the hub.
7. Using a 12mm Allen socket, remove the drain/fill plug and center plug

to allow the wheel end to drain into the catch pan.



**Figure 11-8. Removing Wheel End Drain/Fill Plug and Center Plug**

8. Check and clean the drain/fill plug and center plug, then lube the O-rings on the plugs with the approved SAE 80W90 oil prior to reinstalling.
9. Rotate the wheel end until the outer drain/fill plug is at the 2 o'clock (vertically up and slightly to the side) position.



**Figure 11-9. Installing Wheel End Drain/Fill Plug and Center Plug**

10. Fill the wheel end with approved SAE 80W90 oil until the oil flows out of the center hole.
11. Using a 12mm Allen socket, install the center plug and drain/fill plug. **Torque to 22 ft-lbs (30 Nm).**

12. Repeat Steps 5 through 11 for the opposite wheel end.
13. Lower the vehicle, apply the parking brake, and remove the wheel chocks.
14. Complete service documentation and return the vehicle to service.

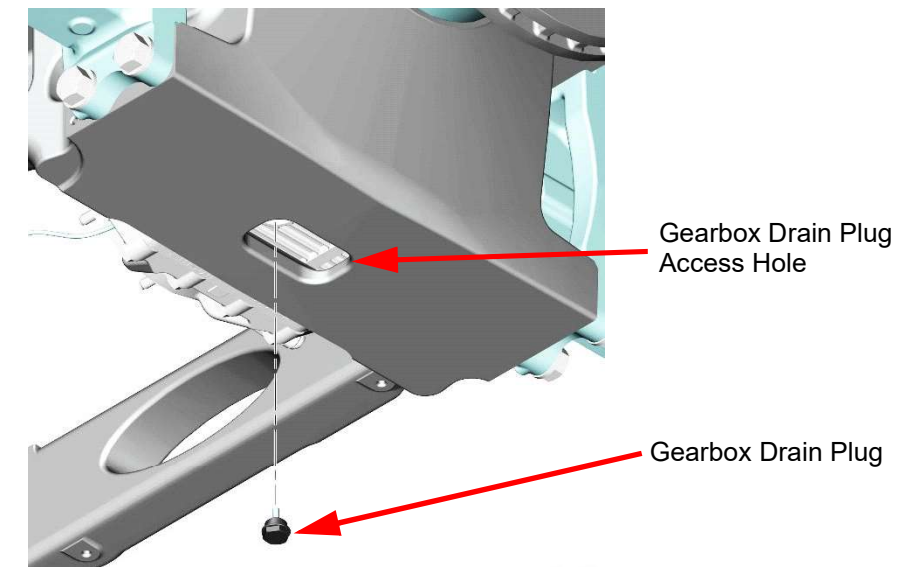
## Drain and Refill Gearbox Fluid

After approximately 100,000 miles (160,934 Km) of service, the gearbox fluid should be drained and refilled with fresh, clean fluid. To change the gearbox fluid, perform the following:

**IMPORTANT!** Read all instructions and know what must be performed prior to starting this procedure! Failure to use extremely clean fluid change techniques can adversely affect the reliability of the gearbox.

1. Drive for approximately 5 miles to bring the vehicle up to operating temperature and to adequately stir up the fluid in the gearbox casing.
 

**Note:** You must be prepared to drain the fluid immediately after shutdown, when the fluid is still at normal operating temperature.
2. Park the bus in the designated service location in position to access the gearbox drain plug and record the bus mileage shown on the odometer.
3. Document the specific bus receiving the fluid change and if required by the Transit Agency, document the gearbox serial number on the bus receiving the fluid change.
4. Thoroughly clean the area around the access hole, drain port, and drain plug.
5. Position a suitable catch pan capable of holding 5 quarts of fluid and remove the gearbox drain plug. Drain the gearbox into the catch pan.



**Figure 11-10. Removing/Installing Gearbox Drain Plug**

6. Check and clean the drain plug and then install the drain plug into the bottom of the gearbox. **Torque drain plug to 18 ft-lbs (24 Nm).**

- Remove the DuoPower Axle skid plate, front/rear cover plates, and top plates to provide access to the gearbox fill plug and sight glass.

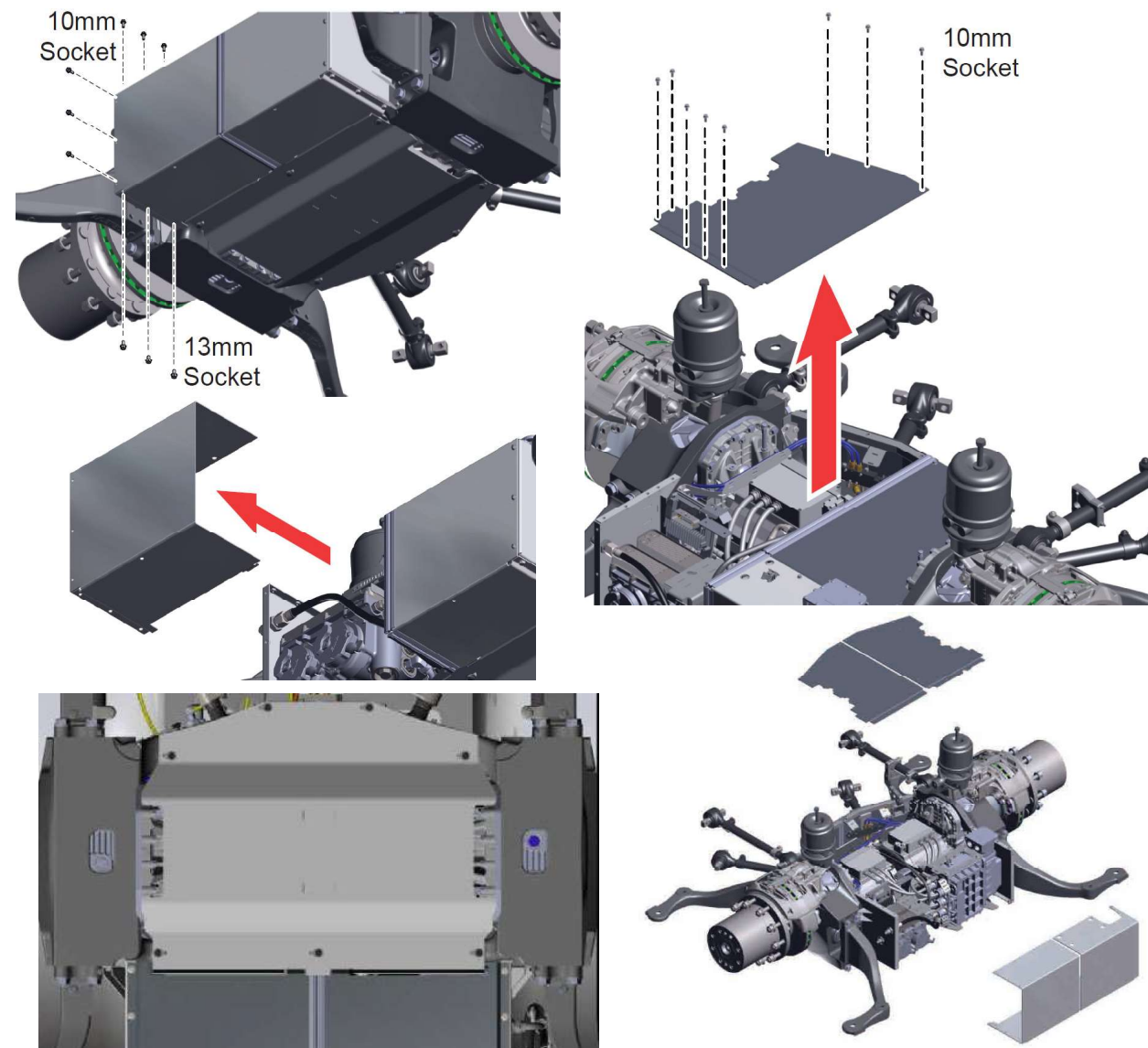


Figure 11-11. Remove DuoPower Axle Skid Plates and Cover Plates

- Remove the gearbox fill plug.

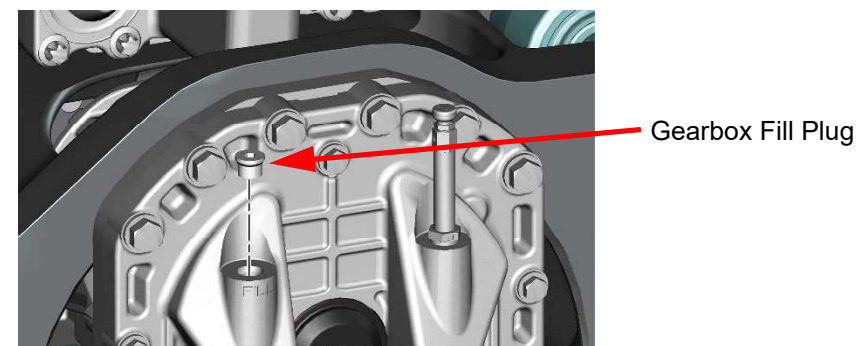


Figure 11-12. Remove Gearbox Fill Plug

- Using a fluid fill pump with angled (hooked) fill tip, fill the gearbox with the recommended fluid (BASF Emgard MTF 7000 Synthetic Transmission Fluid or Shell Spirax S6 GME 40) until seen in the sight glass.

**Note:** Canadian customers can use TRAXON E Synthetic MTF (Synthetic Transmission Fluid) manufactured by Petro-Canada in the gearbox.

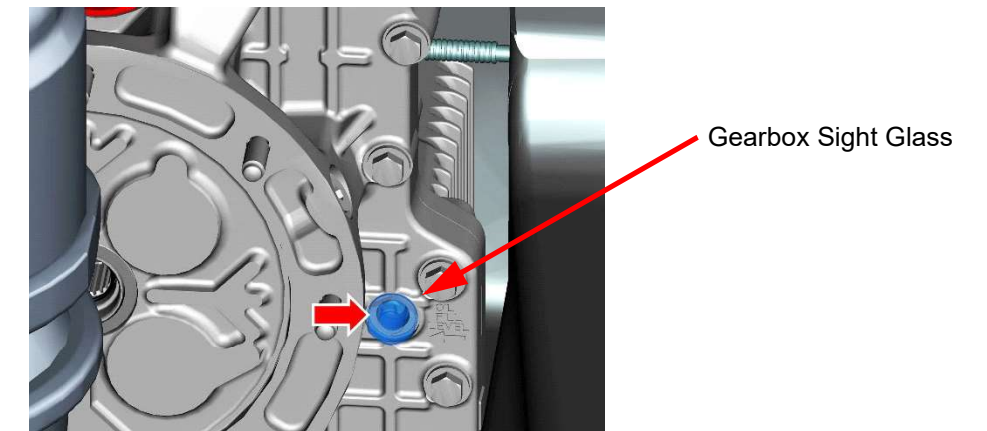


Figure 11-13. Gearbox Sight Glass Location

- Apply a small amount of gearbox fluid to the O-ring seal on the fill plug and then install the gearbox fill plug. **Torque to 13 ft-lbs (18 Nm).**

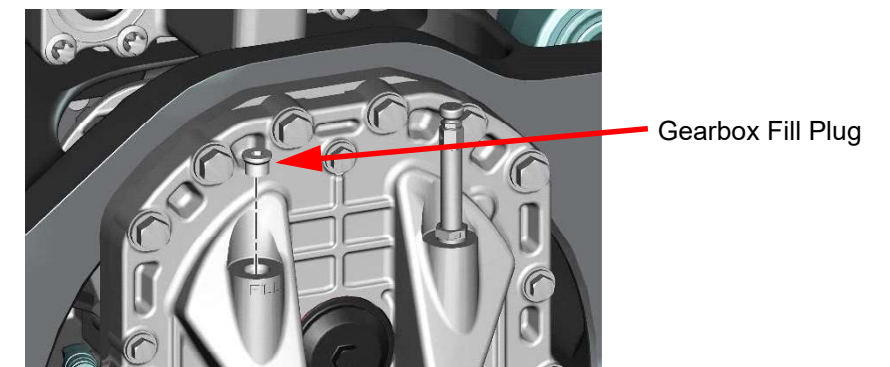


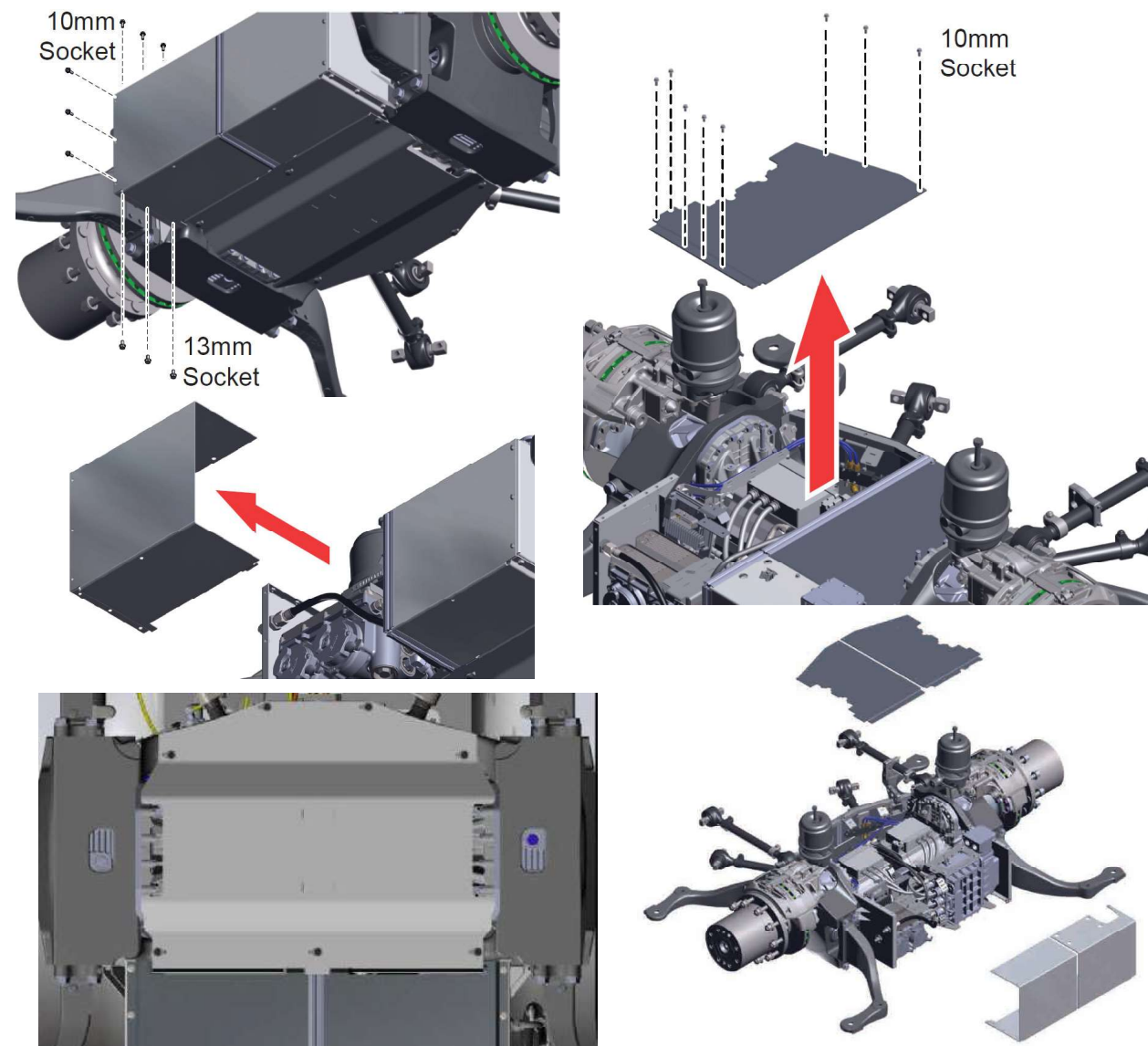
Figure 11-14. Install Gearbox Fill Plug

- Complete gearbox service for the second gearbox before proceeding.

- Complete Oil Pump Module service before proceeding.

**IMPORTANT!** As an integral part of the oil change process, you must replace the oil filters in the oil pump module in addition to the oil itself.

13. To remove potential air pockets from the system, run the oil pumps for one (1) minute to circulate oil through the cooling module and gearboxes.
14. Turn off the oil pumps, then top off each gearbox by visually monitoring the level at the gearbox sight glass.
15. Install the DuoPower Axle skid plate, front/rear cover plates, and top plates when fluid change and top-off procedure for both gearboxes is completed.

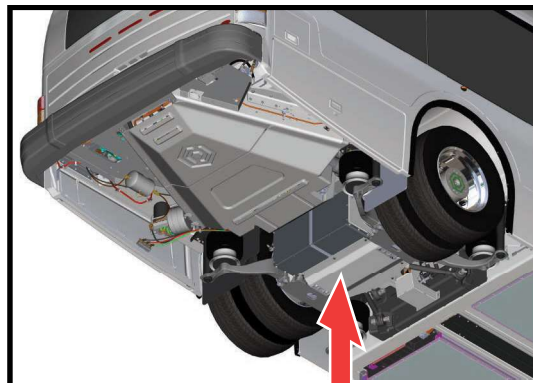


**Figure 11-15. Install DuoPower Axle Skid Plates and Cover Plates**

## DuoPower Axle Removal and Replacement

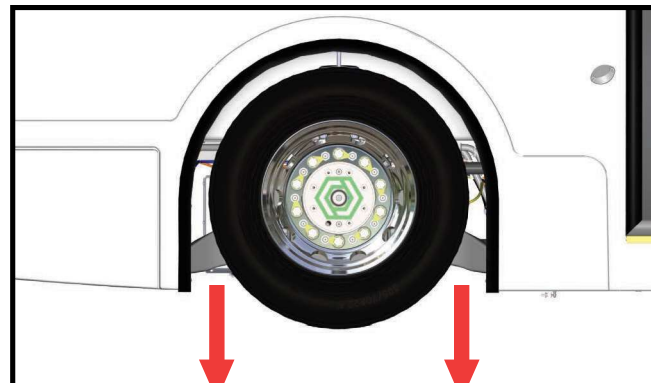
To remove the DuoPower axle from the vehicle, the following tools are recommended:

- Catch Pan and Clean Rags
- Markers and Torque Paint
- Properly Rated Lifting Device (Lift Table)
- 9/16" and 7/8" Socket/Ratchet
- 10mm, 19mm, 27mm Socket/Ratchet
- Hose Pinch Pliers
- Torque Wrenches (rated from 8 ft-lb to 278 ft-lb)
- 50/50 Ethylene Glycol Coolant (OAT compatible)



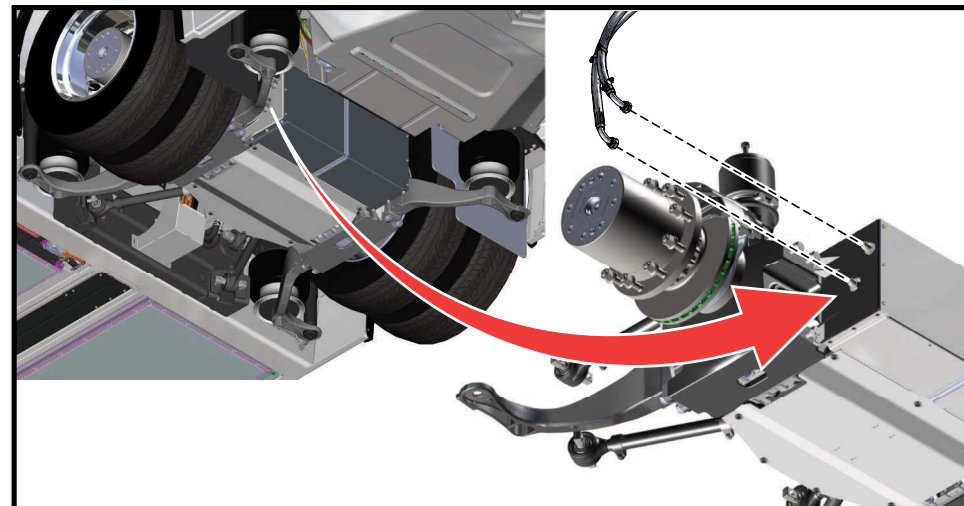
**Step 1**

- Power down the bus.
- Perform lock-out/tag-out.
- Perform Brake System Caging procedure. Refer to Brake System Caging Procedure.
- The DuoPower drive is the rear axle of the bus. Use approved lifting devices and practices to raise the bus. Refer to the guide on bus lifting for further information on how the bus should be lifted.



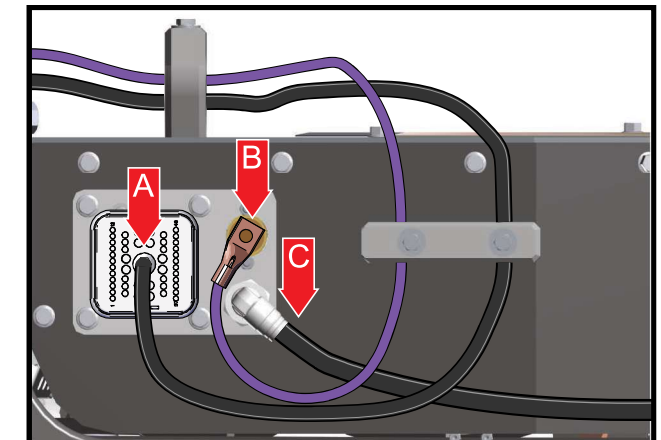
**Step 2**

- Allow the axle to drop as low as possible and the airbags to expand fully.
- Drain the auxiliary air tanks.
- De-pressurize the airbags using the streetside schrader valves and disconnect them from the air lines for safety.
- Position a properly rated lifting device underneath the DuoPower drive.



**Step 3**

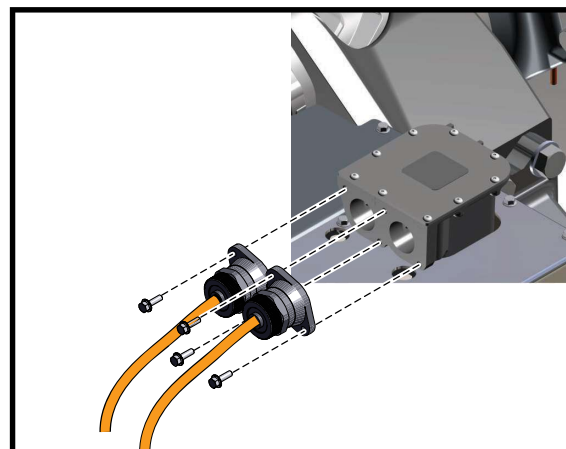
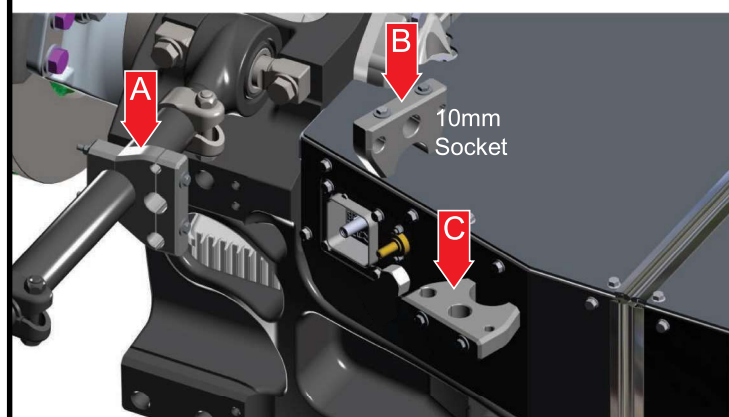
- Using pinch pliers, close off the cooling lines between the chassis and the DuoPower to minimize coolant loss.
- Making note of where the lines are connected for future reference, disconnect cooling lines at the streetside rear of the DuoPower drive.
- Drain coolant into a catch pan, and insert JITC caps into coolant lines to minimize leakage.



**Step 4**

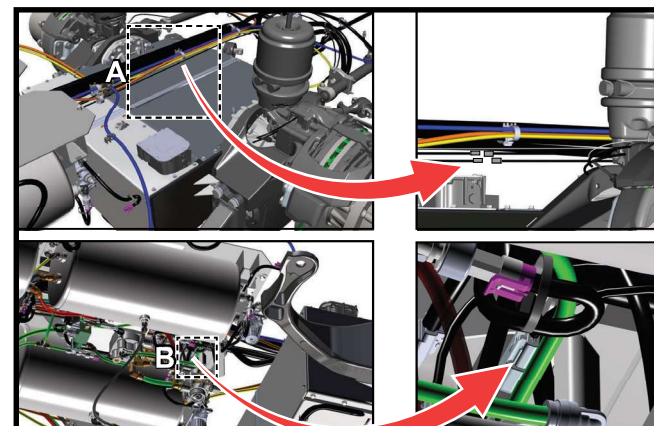
- At the curbside interface plate several connections must be removed.
- Remove low voltage connector (A)
  - Remove the chassis ground (B) --- 9/16"
  - Remove the push-to-connect air fitting (C)

- Step 5**
- Using a 10mm socket, remove the three split blocks from the DuoPower drive.
  - Remove upper curbside control arm (A)
  - On the top of the DuoPower drive, on the curbside cover. (B)
  - On the front of the DuoPower drive, beside the curbside interface area. (C)



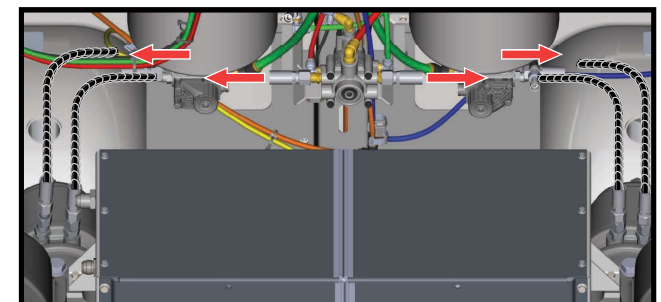
**Step 6**

- Using a 10mm socket, disconnect the max-loc connectors on the 90 degree phase connector at the curbside rear of the DuoPower drive by removing the four 6mm bolts.



**Step 7**

- Document the routing of the ABS sensor harness & brake wear sensor (if installed)
- Cutting zip ties as necessary, disconnect the ABS sensors from the harness at the connector end on the main harness, (A,) and leave the connector end at the wheel connected.
- If installed, also disconnect the brake wear sensor connector (B) at this time. It is routed with the ABS sensor and connect to the main harness in front of the R-14 Relay valve.



**Step 8**

- Disconnect the four brake airlines at the bus, leaving the DuoPower drive end of the lines connected.
- The air lines will be secured with zip ties and swivel base connectors which may have to be removed during the procedure.
- Make note of the location and routing of the four airlines to ensure that they are returned to their proper state during reassembly.

Figure 11-16. DuoPower Axle Removal and Replacement - 1 of 3

**Step 9**

- Position an approved and properly rated lifting device under the DuoPower drive.

**Step 10**

- Using a 7/8" socket, remove the nuts and bushings that secure the suspension to the shocks.
- Using a 19mm socket, remove the nuts that secure the air bag mounts.

**Step 11**

- Using a 27mm socket, remove the control arm from the V-rod bracket.
- Leave the other ends of the control arms (A) attached to the DuoPower drive.

**Step 12**

- Lower the DuoPower drive away from the bus body.
- Secure each air bag piston while the bus is lowering.
- Complete specific procedures to maintain or repair the DuoPower drive. Refer to individual component procedures for additional information.

**Step 13**

- Position an approved and properly rated lifting device under the DuoPower drive, and position it for re-installation.

**Step 14**

- Using a 7/8" socket, install the nuts and bushings that secure the suspension to the shocks.
- Using a 19mm socket, install the nuts that secure the air bag mounts.

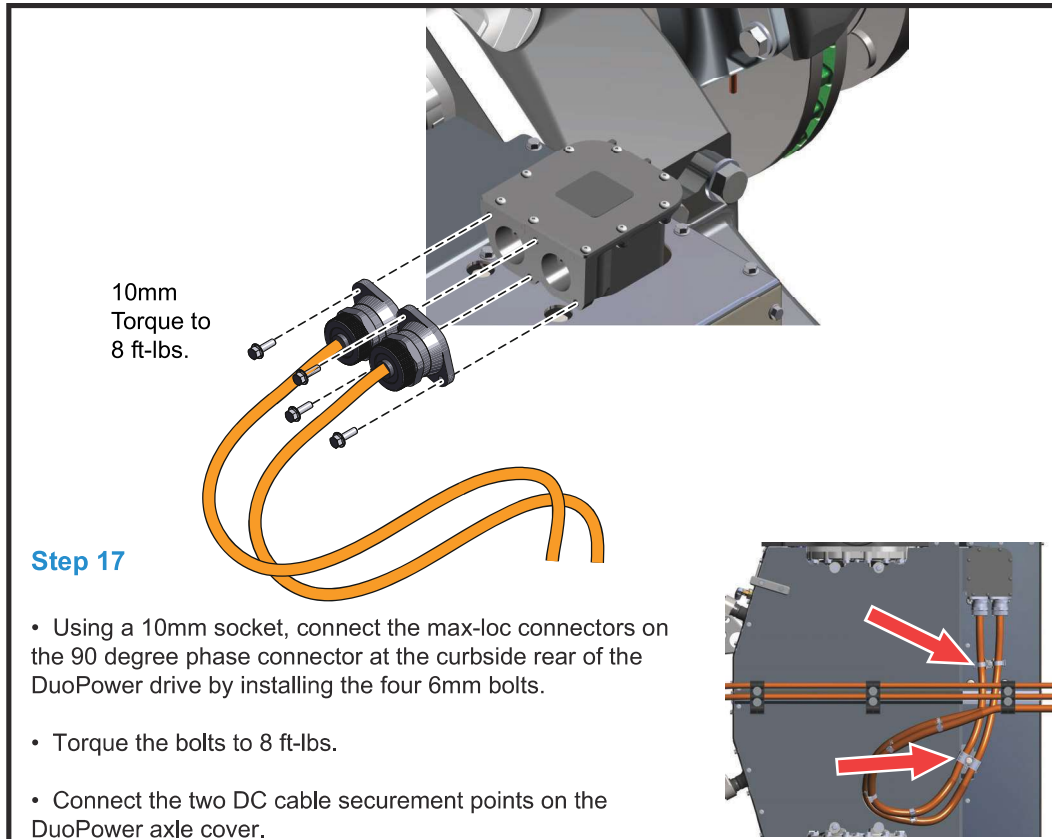
**Step 15**

- Using a 27mm socket, secure the tie rods to the V-rod bracket with the M18x1.5 hex bolts and M18 flat washers.
- Using a 27mm Socket and a torque wrench, torque bolts to 278 ft-lbs.

**Step 16**

- Using a 7/8" socket, tighten and torque the bolts to 20 ft-lbs.

Figure 11-17. DuoPower Axle Removal and Replacement - 2 of 3

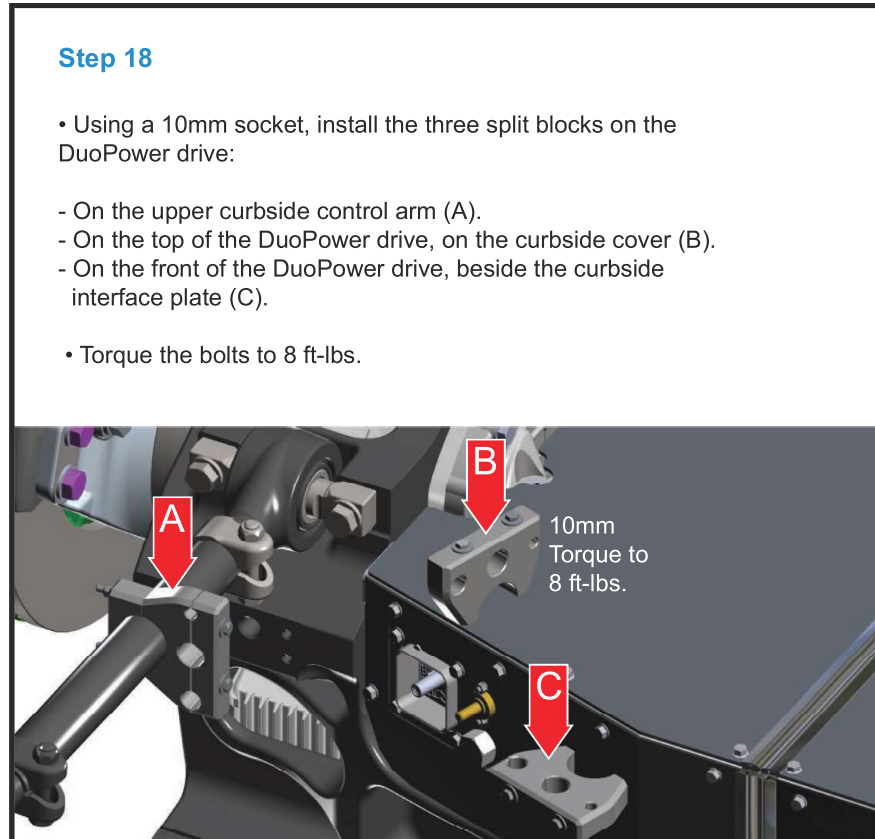


**Step 17**

- Using a 10mm socket, connect the max-loc connectors on the 90 degree phase connector at the curbside rear of the DuoPower drive by installing the four 6mm bolts.
- Torque the bolts to 8 ft-lbs.
- Connect the two DC cable securement points on the DuoPower axle cover.

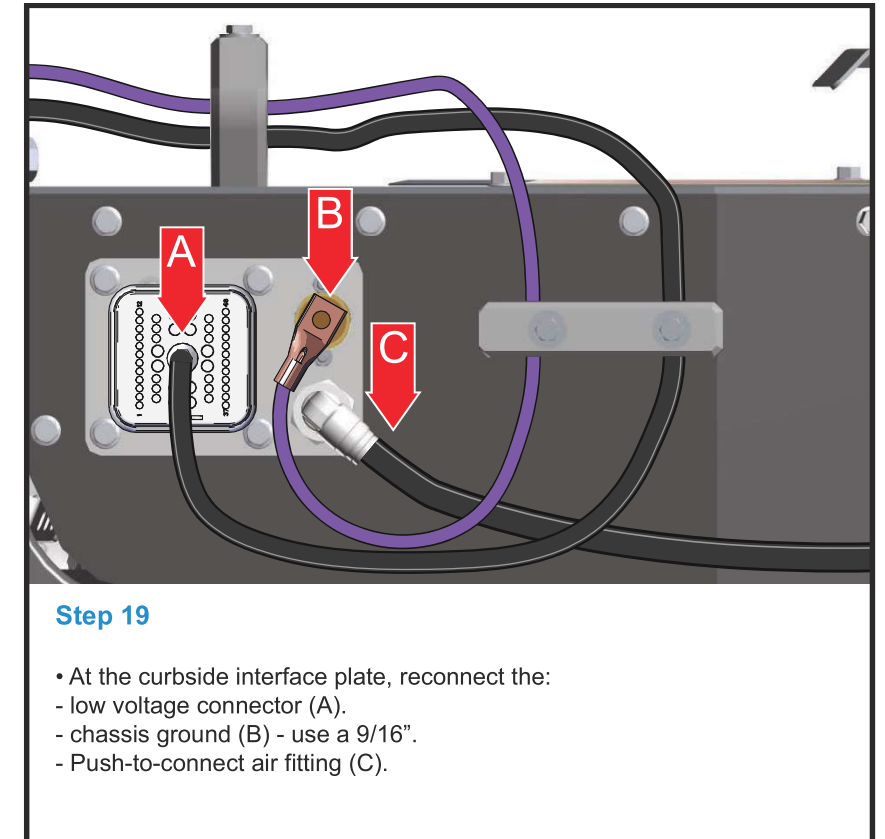
**Step 18**

- Using a 10mm socket, install the three split blocks on the DuoPower drive:
  - On the upper curbside control arm (A).
  - On the top of the DuoPower drive, on the curbside cover (B).
  - On the front of the DuoPower drive, beside the curbside interface plate (C).
- Torque the bolts to 8 ft-lbs.



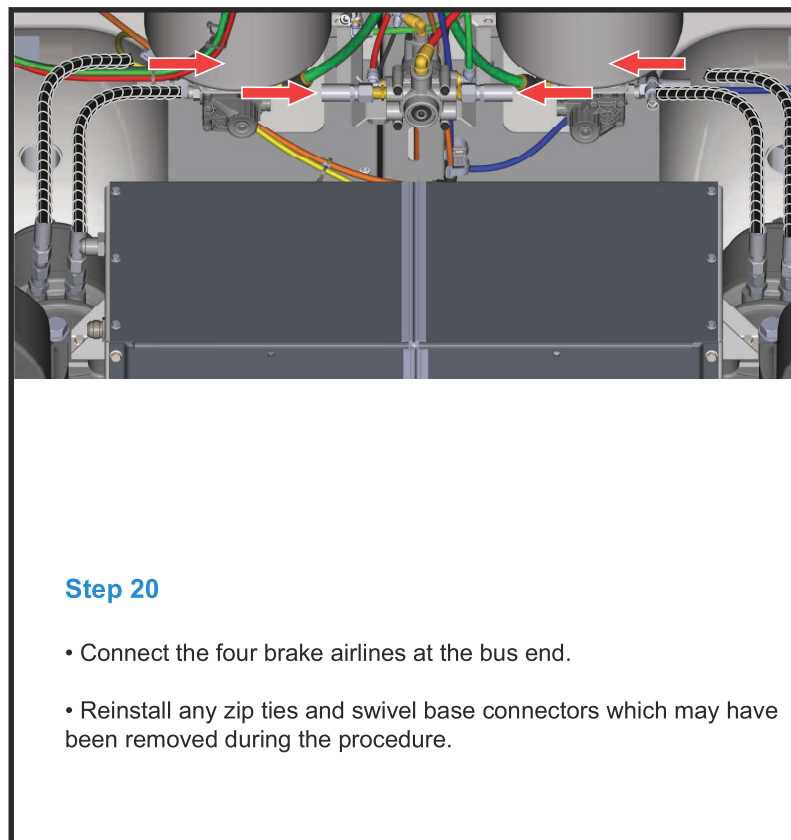
**Step 19**

- At the curbside interface plate, reconnect the:
  - low voltage connector (A).
  - chassis ground (B) - use a 9/16".
  - Push-to-connect air fitting (C).



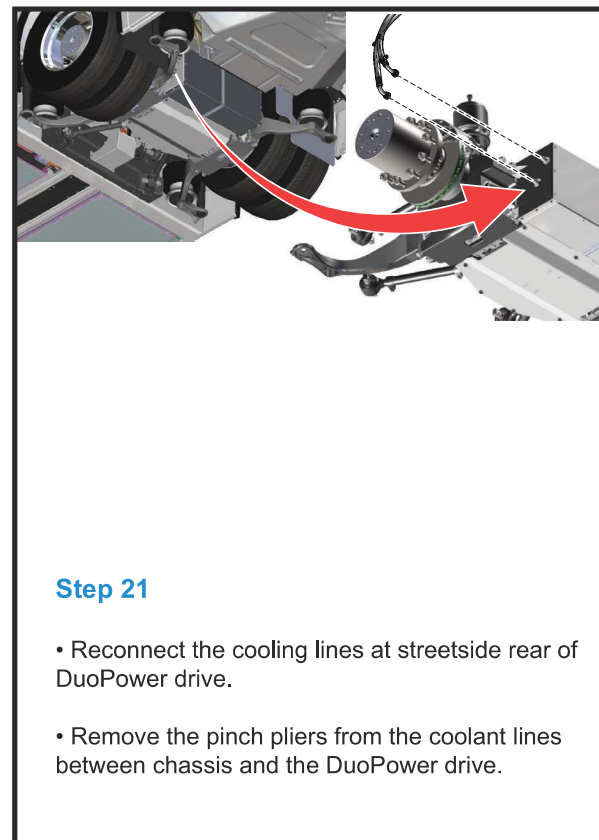
**Step 20**

- Connect the four brake airlines at the bus end.
- Reinstall any zip ties and swivel base connectors which may have been removed during the procedure.



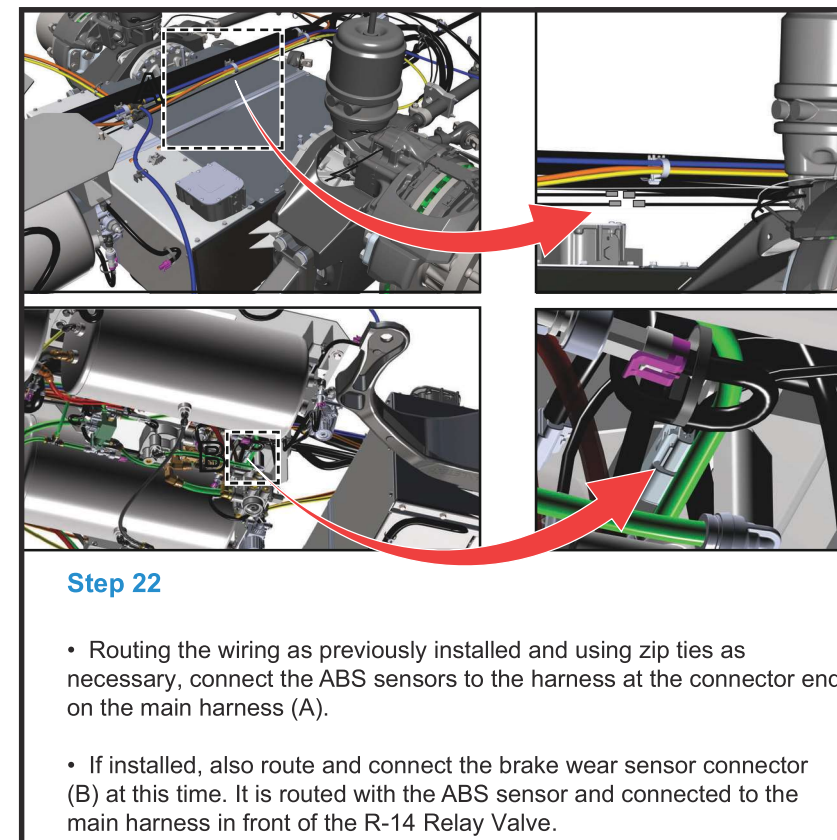
**Step 21**

- Reconnect the cooling lines at streetside rear of DuoPower drive.
- Remove the pinch pliers from the coolant lines between chassis and the DuoPower drive.



**Step 22**

- Routing the wiring as previously installed and using zip ties as necessary, connect the ABS sensors to the harness at the connector end on the main harness (A).
- If installed, also route and connect the brake wear sensor connector (B) at this time. It is routed with the ABS sensor and connected to the main harness in front of the R-14 Relay Valve.



**Step 23**

- Remove lockout/tagout.
- Restore power to the bus.
- Refill coolant loops, as needed.
- Drive a short distance and refill coolant loop.

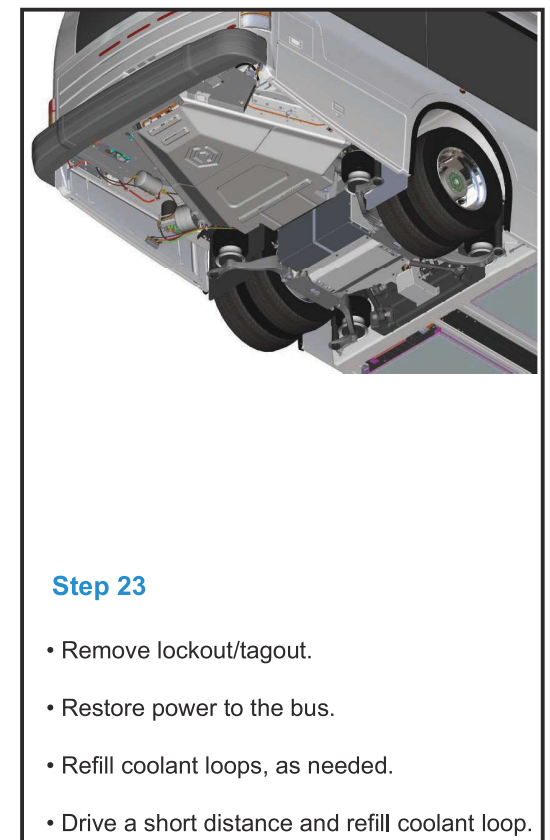


Figure 11-18. DuoPower Axle Removal and Replacement - 3 of 3

## Traction Motor Removal and Replacement

---

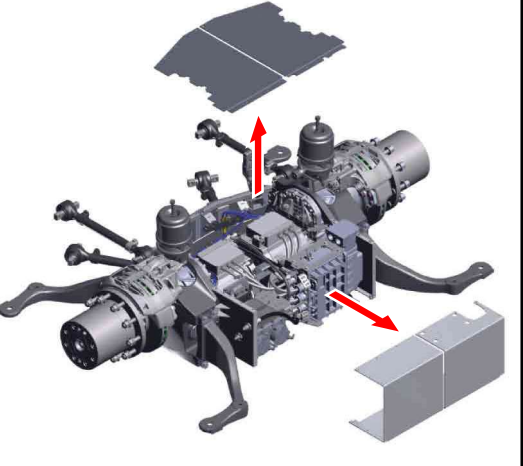
To remove a Traction Motor from the DuoPower frame, the following tools are recommended:

- 1" Combination Wrench
- 10mm Combination Wrench
- 10mm Socket/Ratchet
- 10mm Torque Adapter Extension Tool
- 13mm Socket/Ratchet
- 13mm 12-Point Socket/Ratchet
- 15mm Socket/Ratchet
- 1" Open-Ended Torque Wrench
- 30mm Open-ended Torque Wrench
- 3mm Allen Wrench
- Eyebolts, X2
- 18" Handle Pry Bars
- Shop Air
- Loctite™ 243
- 5/8 fl oz, Chelsea Spline Lubricant, Proterra PN 104-3817
- Torque Wrenches (rated from 30 in-lb to 135 ft-lb)
- Catch Pan
- Clean Rags
- Torque Paint
- Lift Table
- 50/50 Ethylene Glycol Coolant (OAT compatible)
- Shell SPIRAX Synthetic Manual Transmission Oil S6 GME 40
- Channel Lock Pliers
- Hose Pinch Pliers
- Hose Clamp Pliers



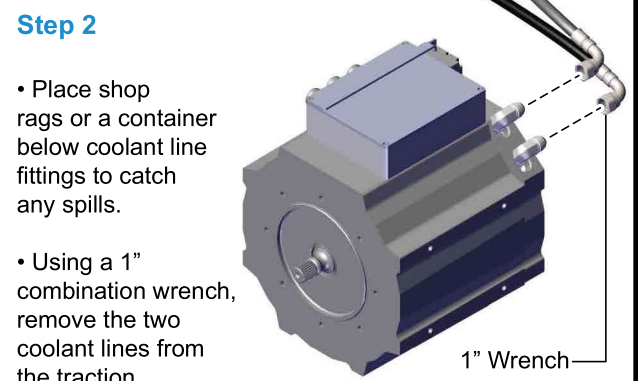
If a Traction Motor or Dual Inverter is replaced AT ANY TIME, you must perform the *Traction Motor/Dual Inverter Pairing Procedure* detailed later in this manual.

---



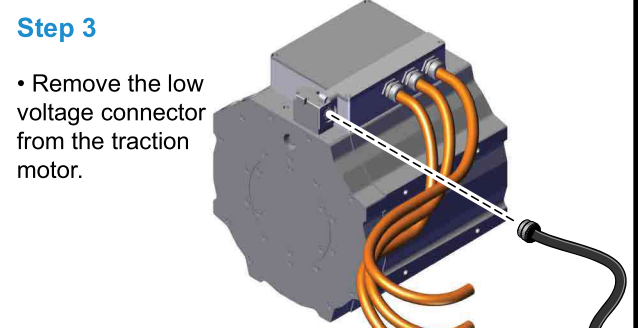
**Step 1**

- Power down the bus.
- Perform lock-out/tag-out.
- Remove the DuoPower axle from the bus.
- Using a 10mm and 13mm socket, remove the top covers and the two back plates.



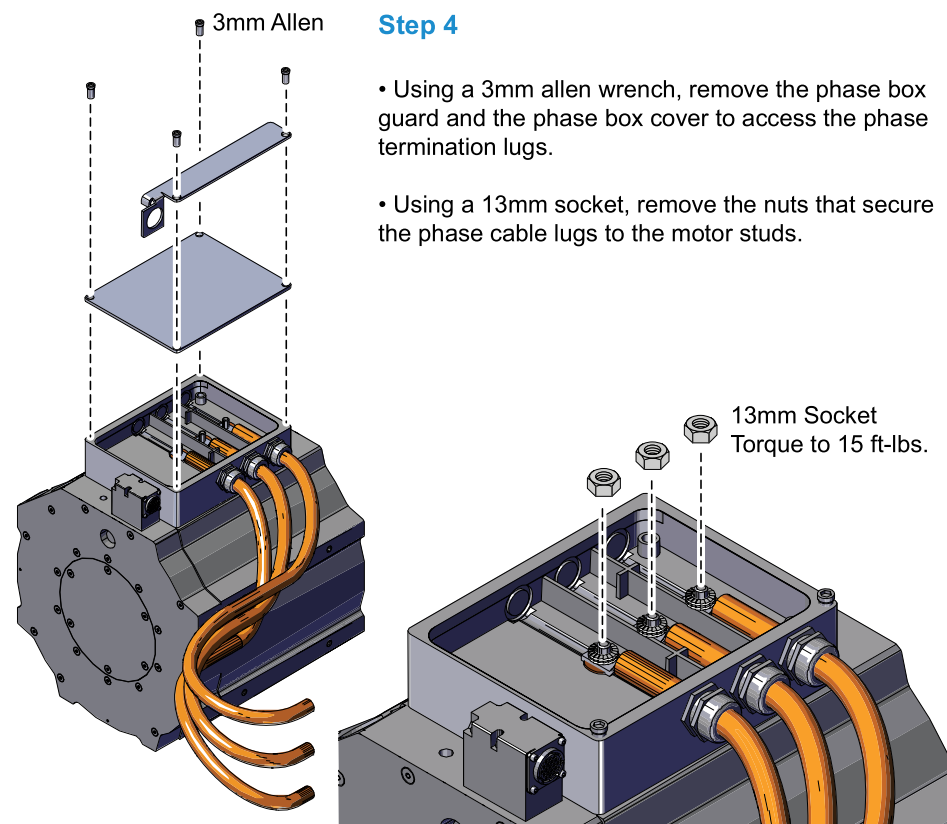
**Step 2**

- Place shop rags or a container below coolant line fittings to catch any spills.
- Using a 1" combination wrench, remove the two coolant lines from the traction motor.



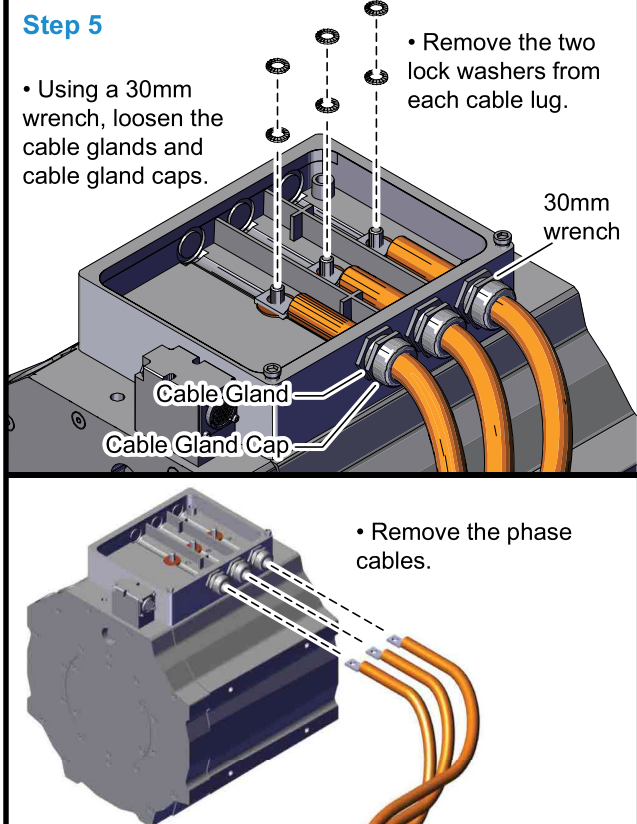
**Step 3**

- Remove the low voltage connector from the traction motor.



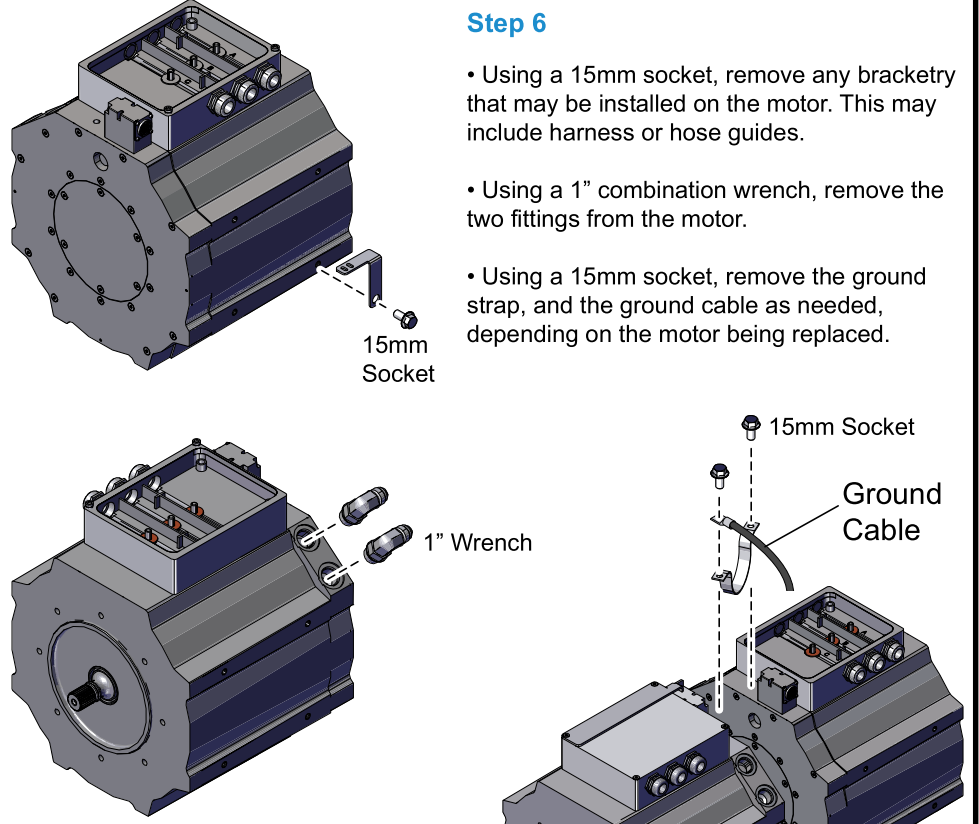
**Step 4**

- Using a 3mm allen wrench, remove the phase box guard and the phase box cover to access the phase termination lugs.
- Using a 13mm socket, remove the nuts that secure the phase cable lugs to the motor studs.



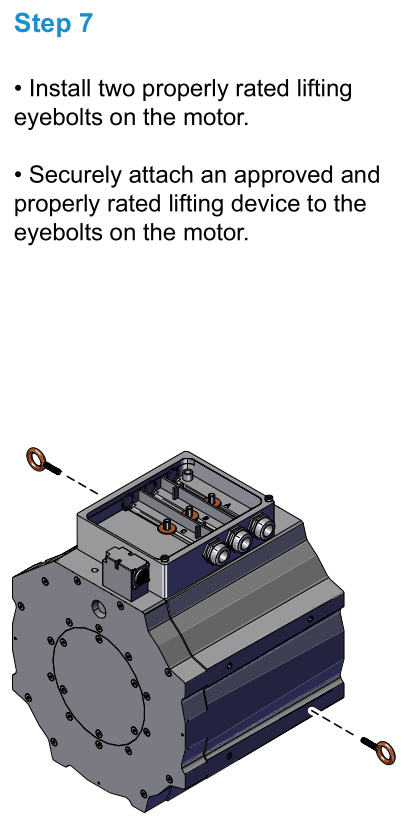
**Step 5**

- Using a 30mm wrench, loosen the cable glands and cable gland caps.
- Remove the two lock washers from each cable lug.



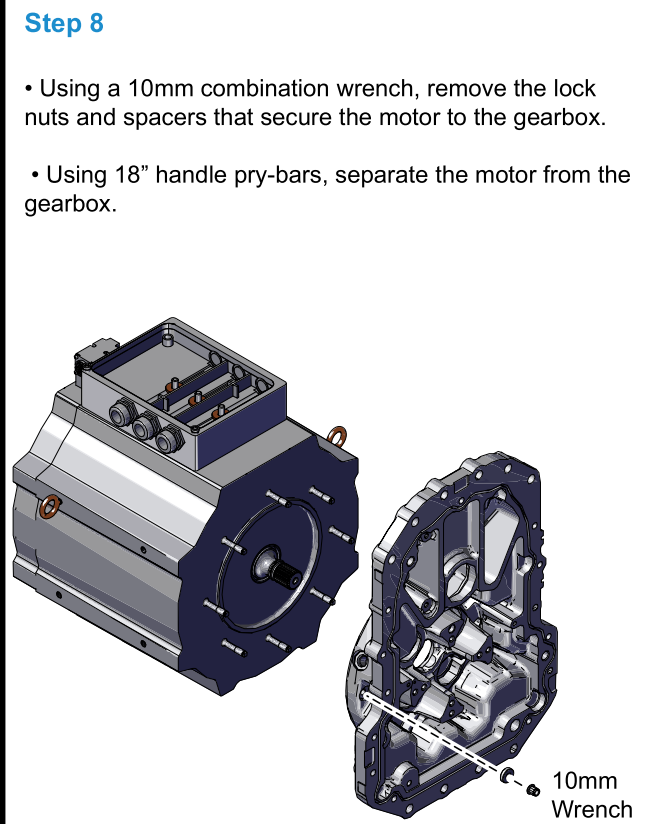
**Step 6**

- Using a 15mm socket, remove any bracketry that may be installed on the motor. This may include harness or hose guides.
- Using a 1" combination wrench, remove the two fittings from the motor.
- Using a 15mm socket, remove the ground strap, and the ground cable as needed, depending on the motor being replaced.



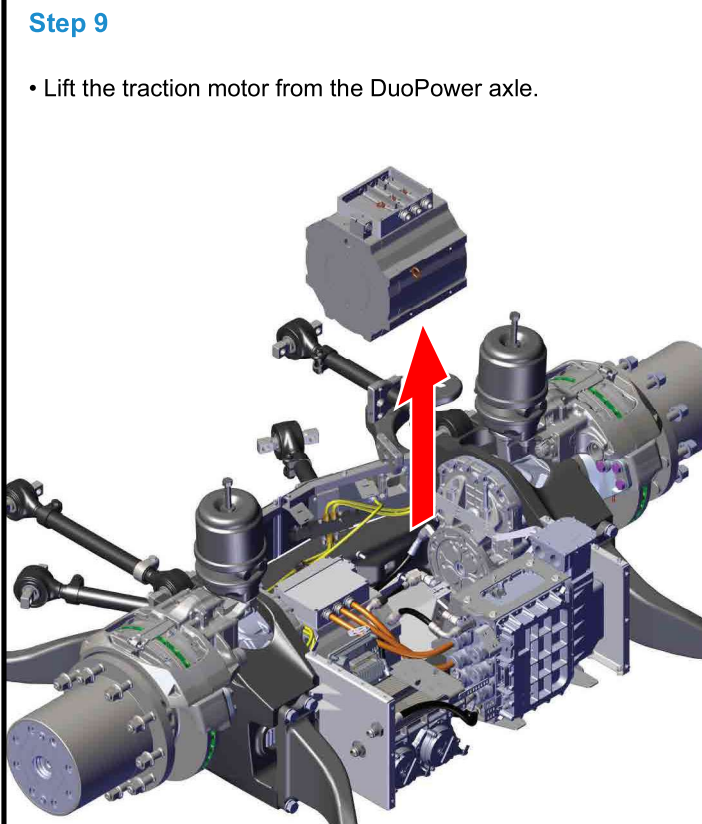
**Step 7**

- Install two properly rated lifting eyebolts on the motor.
- Securely attach an approved and properly rated lifting device to the eyebolts on the motor.



**Step 8**

- Using a 10mm combination wrench, remove the lock nuts and spacers that secure the motor to the gearbox.
- Using 18" handle pry-bars, separate the motor from the gearbox.



**Step 9**

- Lift the traction motor from the DuoPower axle.

Figure 11-19. Traction Motor Removal and Replacement - 1 of 3

**Step 10**

- Installing only ONE manufacturer provided motor stud at a time, apply Loctite™ 263 to a single motor stud, and torque to 53 in-lbs. Repeat for all motor studs.
- Verify all threads are below the mating surface of the traction motor.

**NOTE: Loctite™ may set prior to torquing unless applied and installed individually.**

**Step 11**

- Using manufacturer approved spline lubricant (*Proterra PN 140-3817*), apply entire packet contents to the traction motor output shaft spline prior to installation.

Apply grease

**Step 12**

- Using a properly rated lifting device, lower the traction motor into the DuoPower assembly.

**Step 13**

- Align the traction motor output shaft splines with the internal gearbox splines. If the splines do not align, apply shop air to rotate the hub. Once aligned, push the traction motor into place.

Turn hub

Apply Shop Air

Align Splines

**Step 14**

- Install a spacer on each motor stud. Using Loctite™ 243 on motor studs, install one locknut on each traction motor stud, and hand tighten in torque sequence shown.
- Using 10mm torque wrench, torque each locknut to 13 ft-lb in the torque sequence shown.
- Torque each lock nut a second time to 27 ft-lb and apply a torque stripe to each bolt.

**CAUTION** DO NOT torque until traction motor is fully flush onto gearbox.

10mm Wrench Torque to 13 ft-lb, then 27 ft-lb.

Apply Torque Stripe

Gearbox (Shown from traction motor side)

**Step 15**

- Using a 15mm socket, re-install the required bracketry using M10 bolts. This may include harness or hose guides.
- Torque the bolts to 20 ft-lb and apply a torque stripe to each bolt.
- Using a 1" combination wrench, install the two fittings on the motor.
- Torque fittings to 65 ft-lb.

Apply Torque Stripe

1" Wrench Torque to 65 ft-lb.

15mm Socket Torque to 20 ft-lb.

**Step 16**

- Apply Loctite™ 243 to each 15mm ground strap bolt.
- Using a 15mm socket, re-install both the ground strap between the motors, and the ground cable from the inverter to the streetside motor, as shown. Torque to 25 ft-lb.
- Apply a torque stripe to each bolt.

15mm Socket Torque to 25 ft-lb.

Ground Cable From Inverter

Apply Torque Stripe

**Step 17**

- Route the phase cables into the motor phase box.
- Using a 30mm open-ended torque wrench, install and torque each phase cable gland to the phase cable box to 89 in-lb.
- Using a 30mm open-ended torque wrench, install and torque each phase cable gland cap to 62 in-lb.

Cable Gland 30mm Torque to 89 in-lb.

Cable Gland Cap 30mm Torque to 62 in-lb.

Figure 11-20. Traction Motor Removal and Replacement - 2 of 3

## Gearbox Removal and Replacement

To remove a Gearbox from the DuoPower frame, the following tools are recommended:

- Catch Pan (oil drain)
- Clean Rags
- SKF TMFS 5 Socket (special tool)
- 10mm Socket/Ratchet
- 13mm Socket/Ratchet
- 16mm Socket/Ratchet
- 19mm Socket/Ratchet
- Small Flat-Blade Screwdriver
- Needle Nose Pliers
- Lifting Device (properly rated)
- Keeper Ring (replacement part)
- Torque Wrenches (rated from 8 ft-lb to 100 ft-lb)
- Loctite 242
- Torque Paint
- Marker



If a Traction Motor or Dual Inverter is replaced AT ANY TIME, you must perform the *Traction Motor/Dual Inverter Pairing Procedure* detailed later in this manual.

**Step 18**

- Install two lock washers on top of each cable lug, with the large serrations facing each other, and the small serrations facing the lug and the nut.

**Step 19**

- Using a 13mm socket, install the nuts that secure the phase cables to the motor.
- Torque the phase cable nuts to 15 ft-lb and apply a torque stripe.

13mm Torque to 15 ft-lb.

Apply Torque Stripe

3mm Allen Torque to 18 in-lb.

- Using a 3mm Allen bit, secure the phase box covers to the phase box.
- Torque the screws to 18 in-lb.

**Step 20**

- Using a 1" open-ended torque wrench, install and torque both coolant lines to 60 ft-lb.

1" Wrench Torque to 60 ft-lb.

**Step 21**

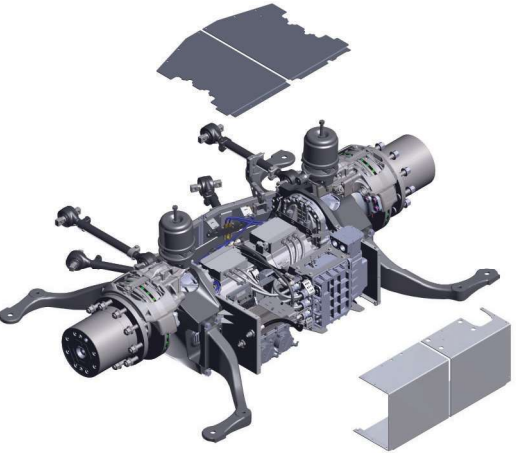
- Connect the low voltage connector to the traction motor.

**Step 22**

- Using a 10mm and 13mm socket, install the top covers and the two back plates. Torque the bolts to 8 ft-lb. and apply a torque stripe.
- Re-install the DuoPower axle onto the bus.
- Remove lockout/tagout and restore power to the bus.
- Perform *Traction Motor/Dual Inverter Pairing Procedure*.

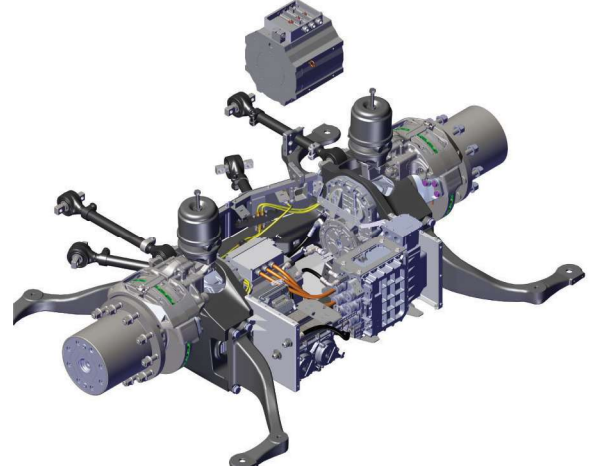
Apply Torque Stripe

Figure 11-21. Traction Motor Removal and Replacement - 3 of 3



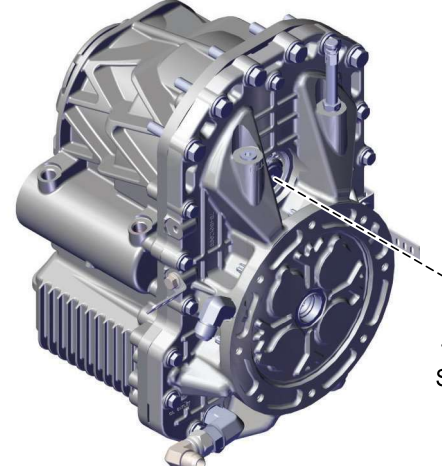
**Step 1**

- Power down the bus.
- Perform lockout/tagout.
- Remove the DuoPower drive from the bus.
- The gearboxes are located between the traction motors and the wheel ends.



**Step 2**

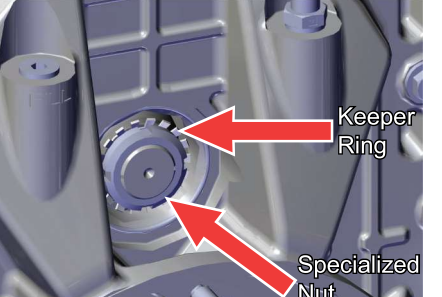
- Following oil removal guidelines, drain gearbox oil from the gearbox being serviced.
- Using 10mm and 13mm sockets, remove the top covers and back plates of the DuoPower drive.
- Remove traction motor from gearbox being serviced.



**Step 3**

- Disconnect the oil inlet and outlet hoses from the gearbox.
- Using a 16mm socket, remove the cap from the shaft spacer sleeve.
- Discard the cap.

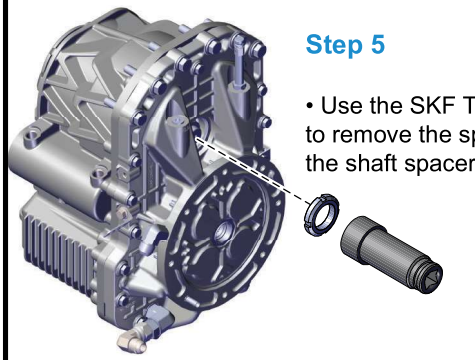
16mm Socket



**Step 4**


- Using a flat blade screwdriver, bend the keeper ring tab out of the notches in the special nut.

Keeper Ring  
Specialized Nut



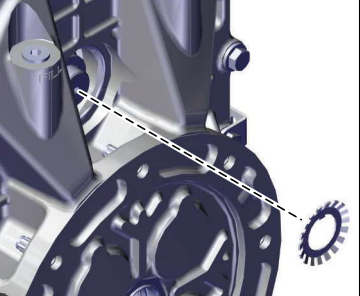
**Step 5**

- Use the SKF TMFS 5 socket to remove the special nut from the shaft spacer.



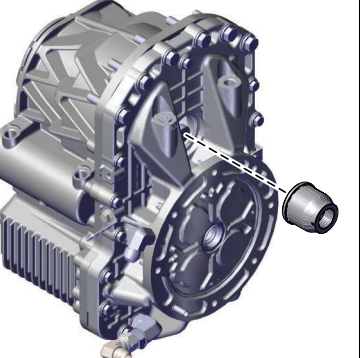
**Step 6**

- Remove the breather tube from the gearbox.



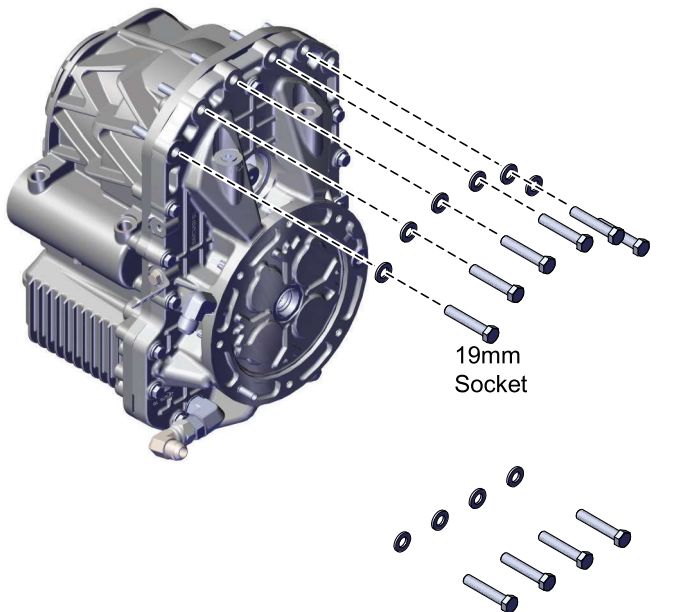
**Step 7**

- Using needle nose pliers, remove the keeper ring from the shaft spacer.
- Discard the keeper ring.



**Step 8**

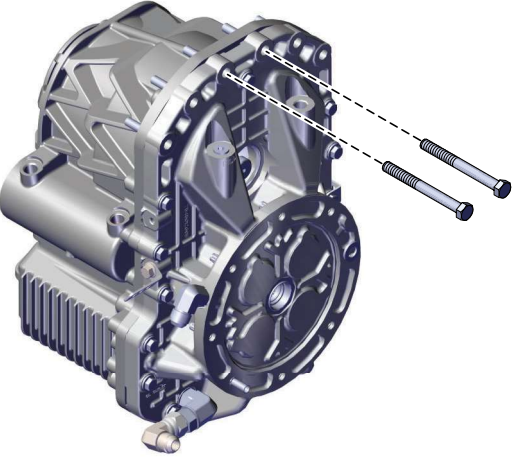
- Using a small flat blade or other precision instrument, slide the bushing, or shaft spacer, out of the gearbox assembly.



**Step 9**

- Using a 19mm socket, remove the six bolts and washers from the top of the gearbox, and the four bolts at the bottom.

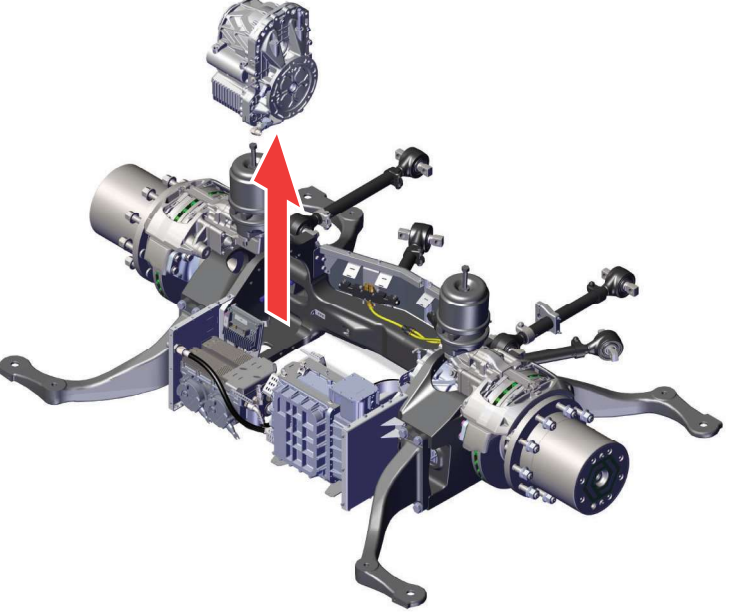
19mm Socket



**Step 10**

- Insert two long bolts in the two topmost holes to temporarily secure the gearbox.

• **CAUTION:** This provides extra support for the gearbox as it is being prepared to be lifted and is an important safety measure.



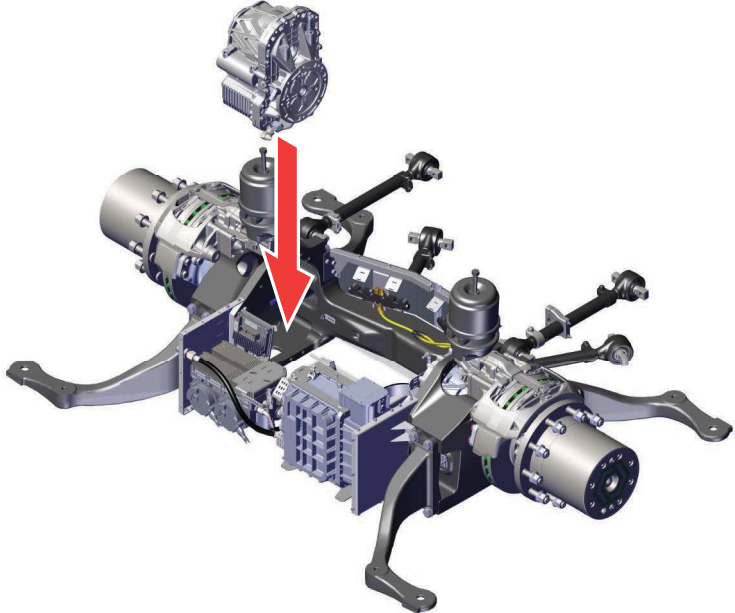
**Step 11**

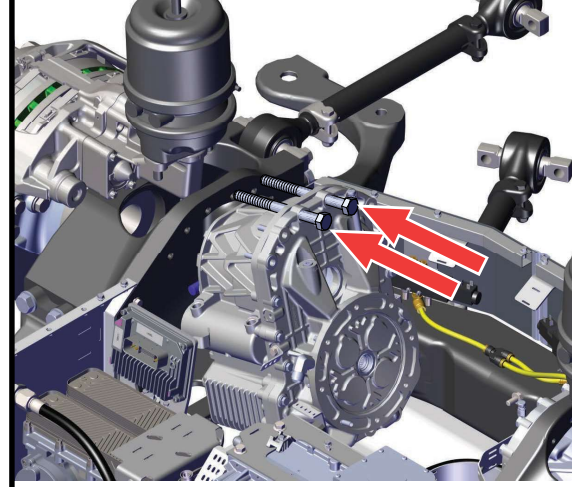
- Using an approved lifting device, lift the gearbox from the DuoPower Drive.

Figure 11-22. Gearbox Removal and Replacement - 1 of 3

**Step 12**

- Using an approved lifting device, lower the gearbox into the DuoPower Drive.



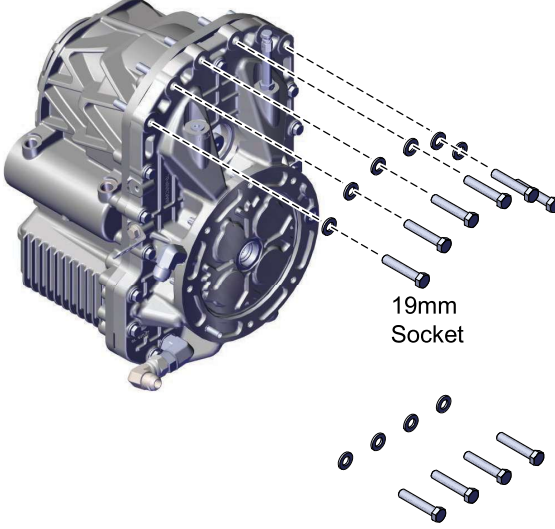


**Step 13**

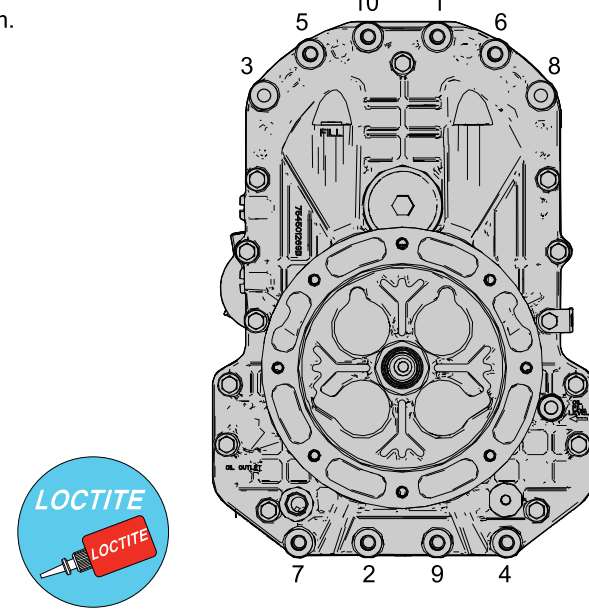
- As the gearbox is lowered into place, use the inserted long bolts to safely guide the gearbox into the proper seating position.

**Step 14**

- Apply Loctite 242 prior to installation.
- Using a 19mm socket, secure the gearbox to the DuoPower frame with the six bolts and washers at the top of the gearbox, and the four bolts at the bottom.

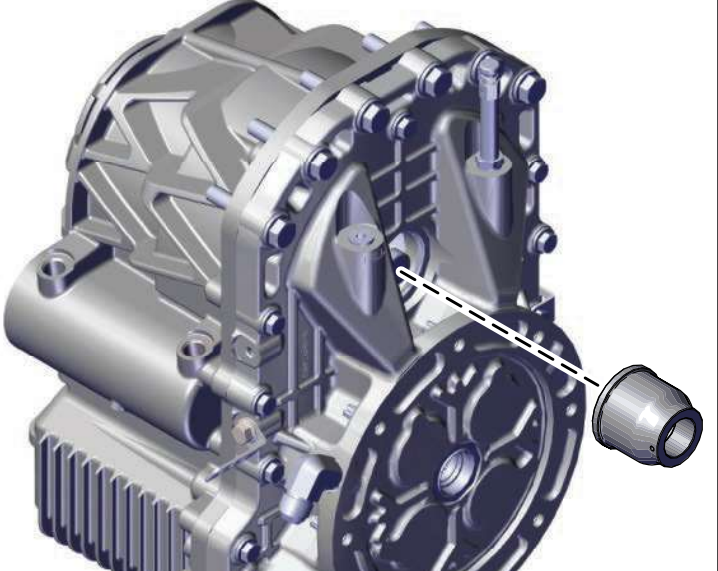


19mm Socket



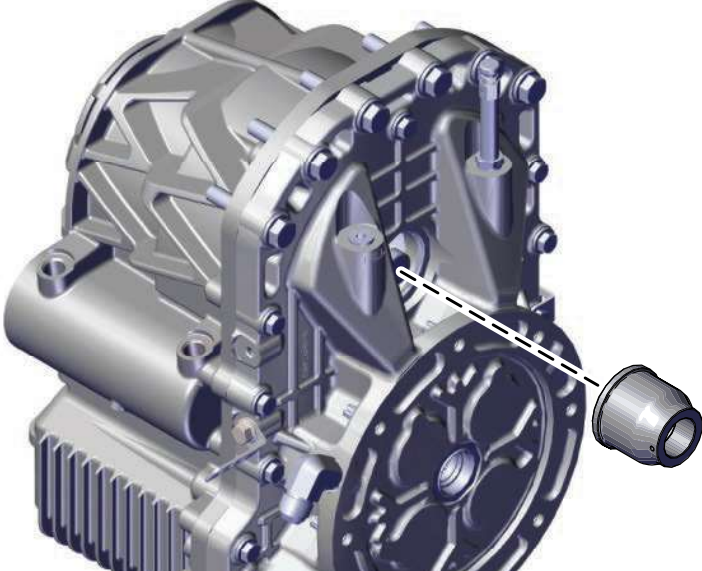
**Step 15**

- Using the provided pattern, evenly tighten the bolts.
- NOTE:** Do not torque the bolts at this time.



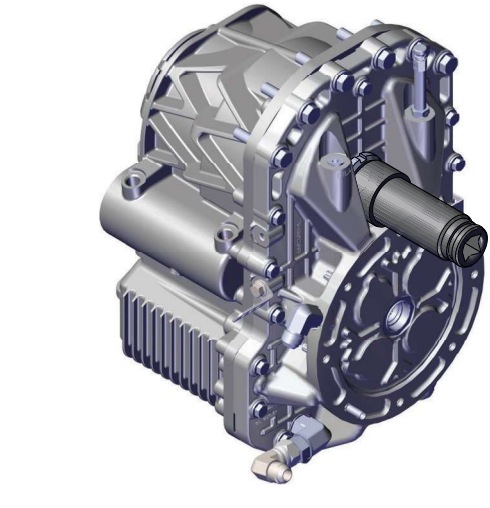
**Step 16**

- Slide the bushing, or shaft spacer, into the gearbox assembly.



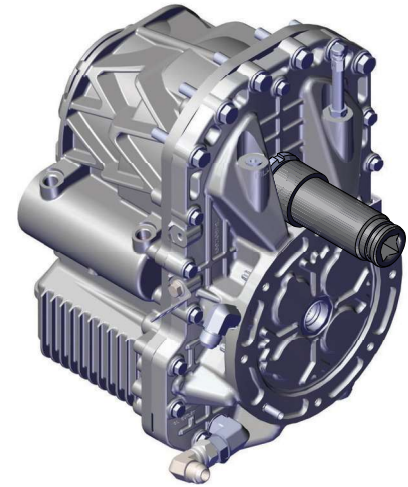
**Step 17**

- Use the SKF TMFS 5 socket to replace the special nut from the shaft spacer. **Do not install the keeper ring at this time.**



**Step 18**

- Use the SKF TMFS 5 to tighten the special nut. This will fully seat the shaft spacer sleeve.



**Step 19**

- Use the SKF TMFS 5 to remove the special nut.

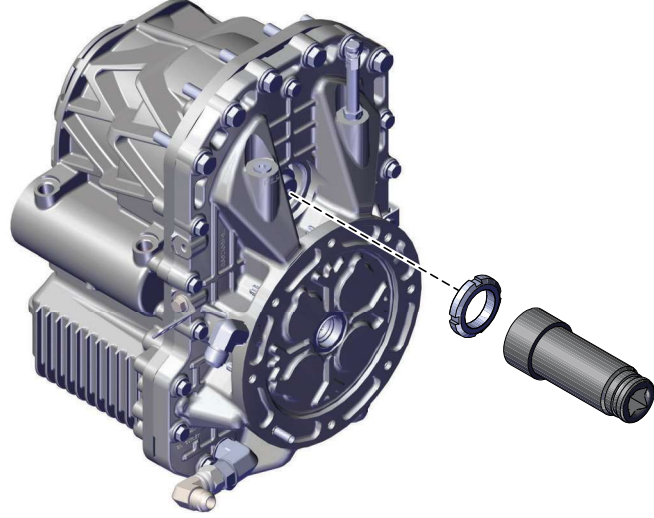


Figure 11-23. Gearbox Removal and Replacement - 2 of 3

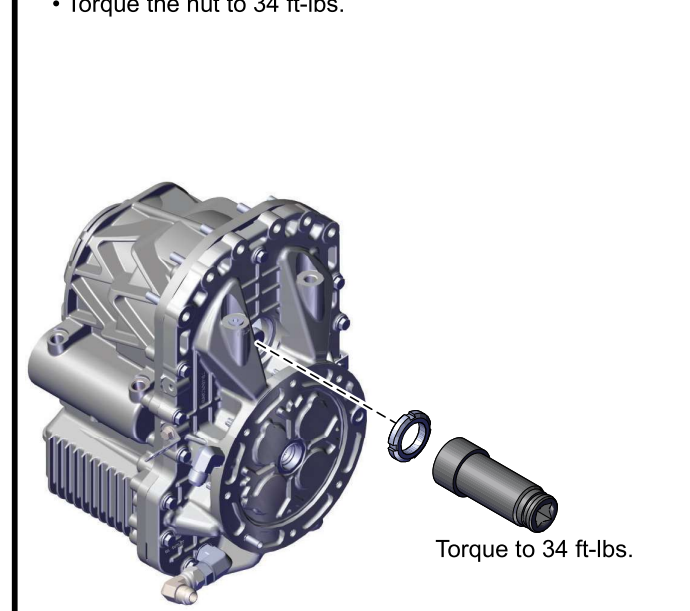
**Step 20**

- Install a new keeper ring on the shaft spacer with the internal tab in the notch on the shaft.

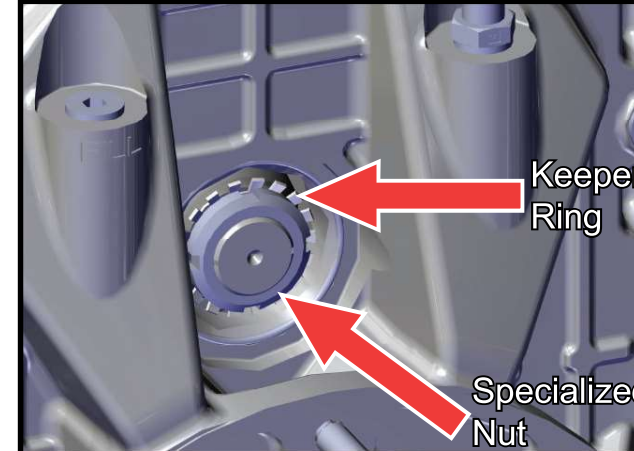


**Step 21**

- Replace the special nut with the beveled edge toward the keeper ring.
- Torque the nut to 34 ft-lbs.




Torque to 34 ft-lbs.



Keeper Ring  
Specialized Nut

**Step 22**

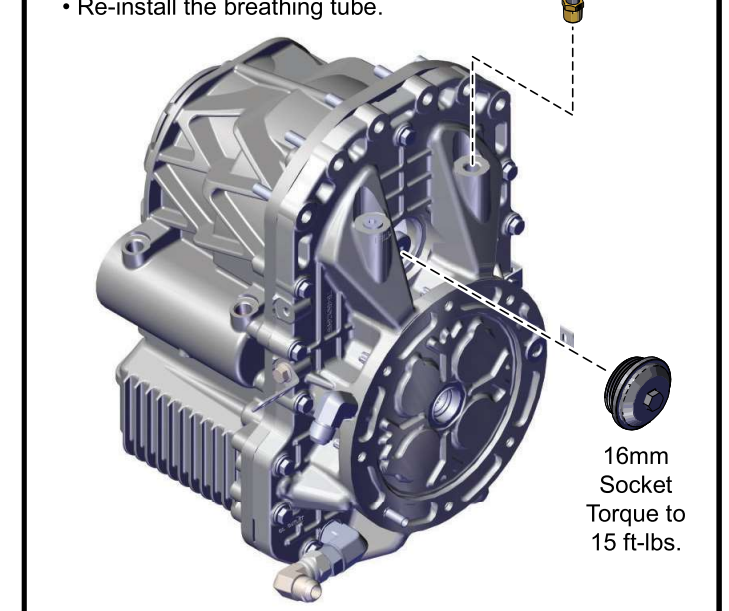
- Using a flat blade screwdriver, bend the keeper ring tab into the notch in the special nut.
- Mark the tab with a torque stripe.



Apply Torque Stripe

**Step 23**

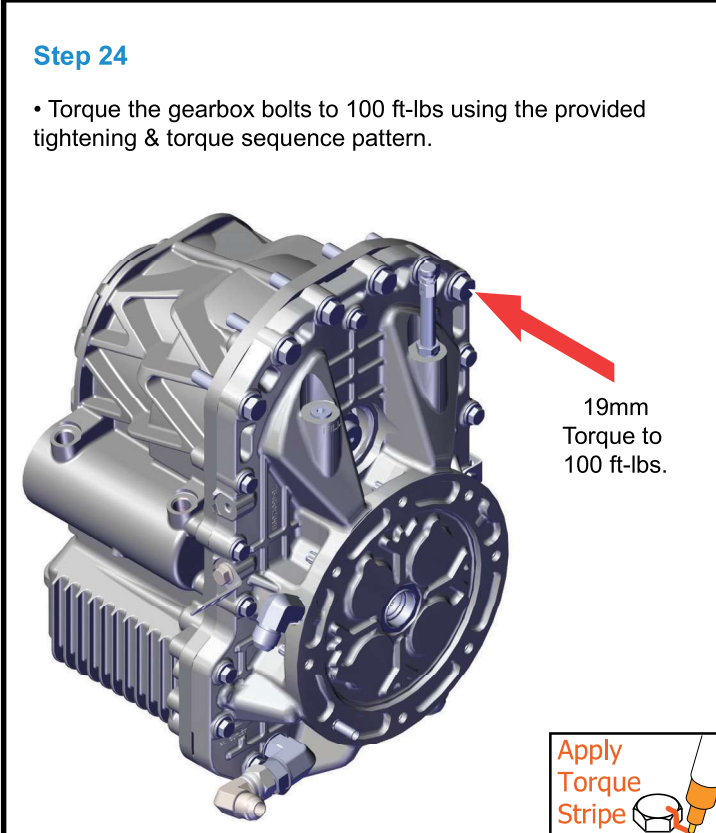
- Connect the oil inlet and outlet hoses to the gearbox.
- Using a 16mm socket, install a new cap. Torque the cap to 15 ft-lbs.
- Re-install the breathing tube.




16mm Socket  
Torque to 15 ft-lbs.

**Step 24**

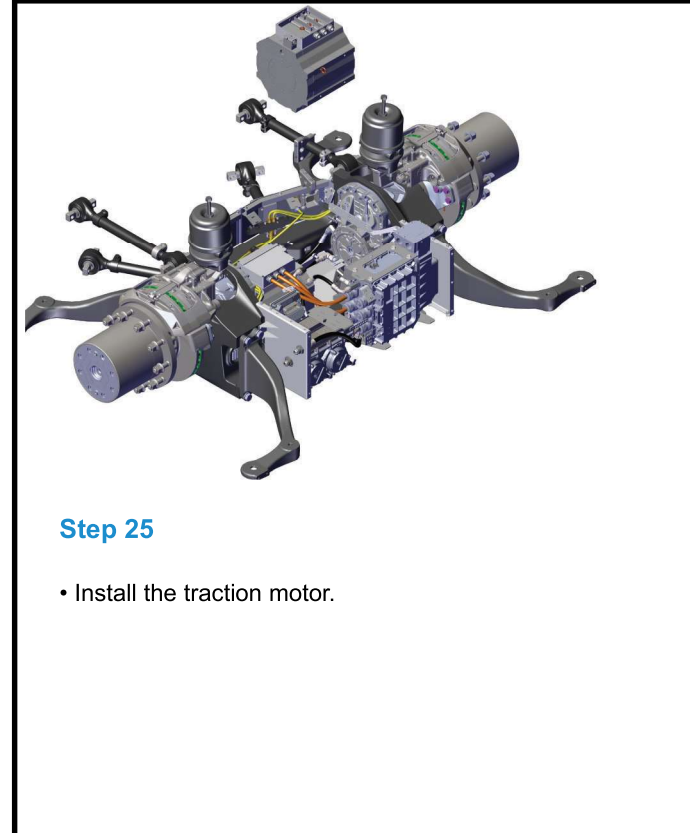
- Torque the gearbox bolts to 100 ft-lbs using the provided tightening & torque sequence pattern.



19mm Torque to 100 ft-lbs.

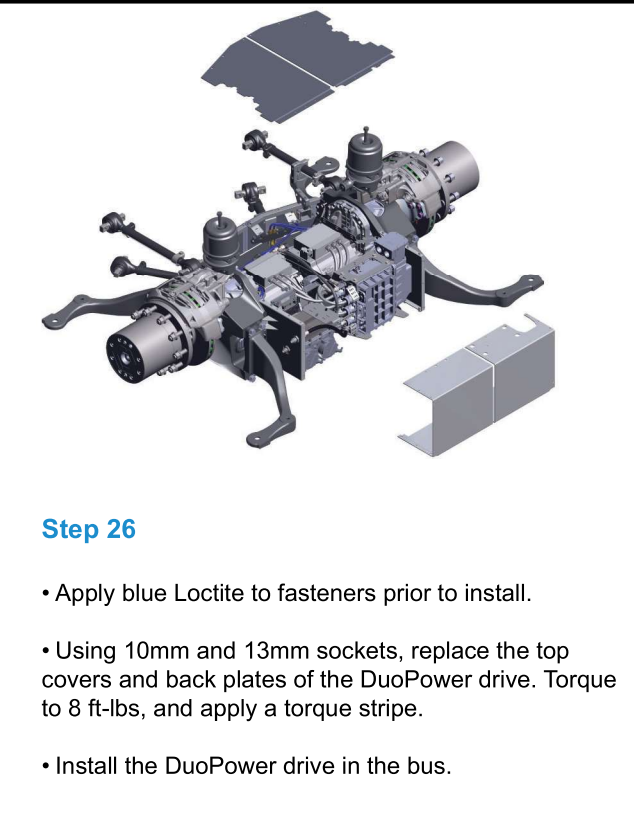


Apply Torque Stripe



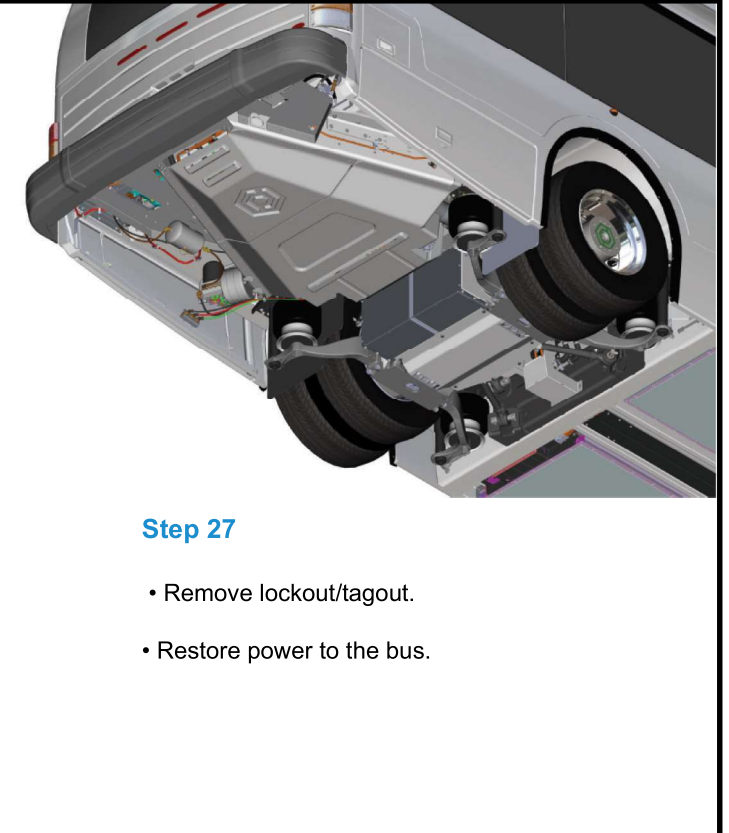
**Step 25**

- Install the traction motor.



**Step 26**

- Apply blue Loctite to fasteners prior to install.
- Using 10mm and 13mm sockets, replace the top covers and back plates of the DuoPower drive. Torque to 8 ft-lbs, and apply a torque stripe.
- Install the DuoPower drive in the bus.



**Step 27**

- Remove lockout/tagout.
- Restore power to the bus.

Figure 11-24. Gearbox Removal and Replacement - 3 of 3

## Dual Inverter Removal and Replacement

---

To remove the Dual Inverter from the DuoPower frame, the following tools are recommended:

- Catch Pan
- Clean Rags
- 8mm Socket/Ratchet
- 10mm Socket/Ratchet
- 13mm Socket/Ratchet
- 15mm Socket/Ratchet
- 1-1/16" Combination Wrench
- Hose Pinch Pliers
- Torque Wrenches (rated from 8 ft-lb to 35 ft-lb)
- Loctite
- Torque Paint
- Marker



If a Traction Motor or Dual Inverter is replaced AT ANY TIME, you must perform the *Traction Motor/Dual Inverter Pairing Procedure* detailed later in this manual.

---

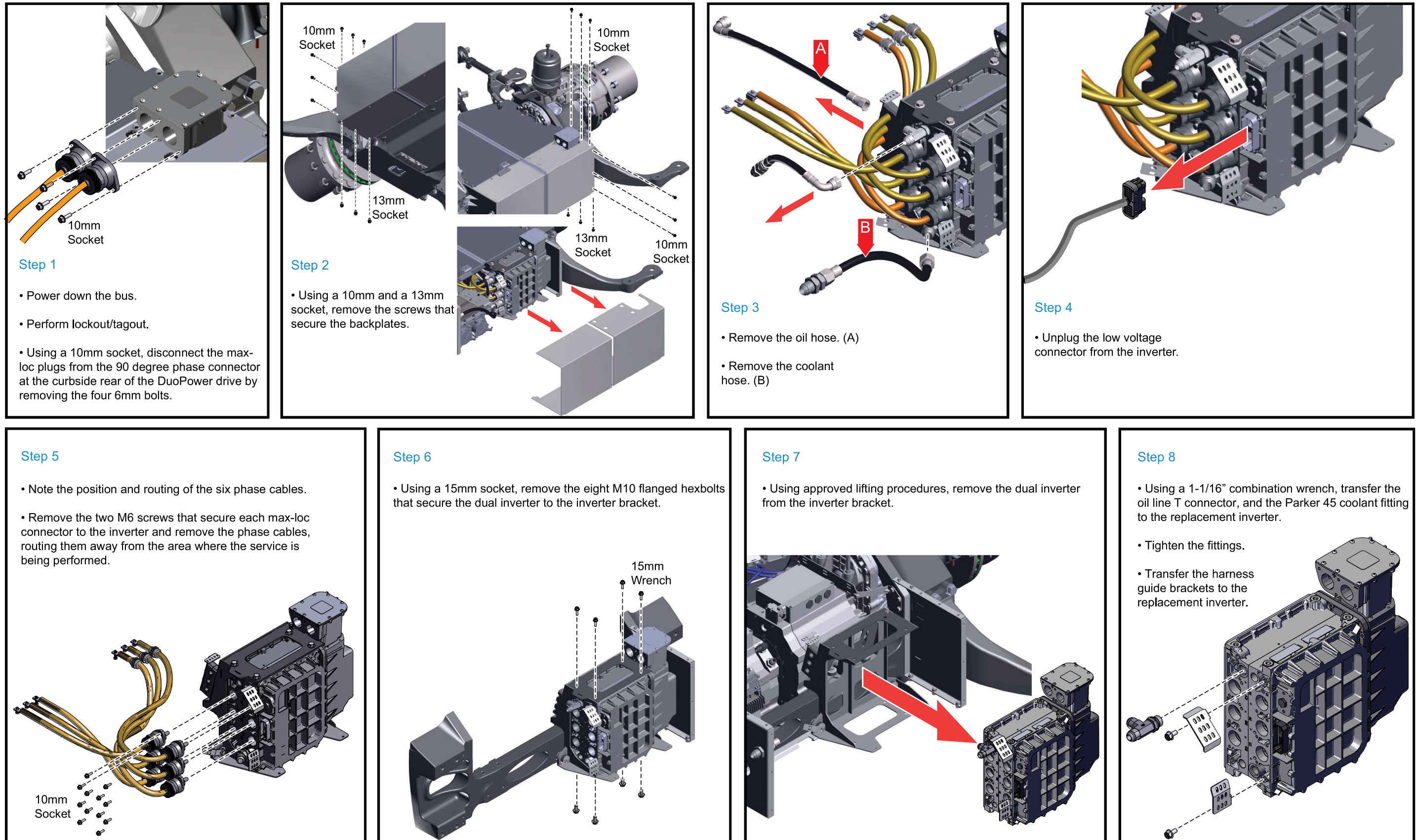
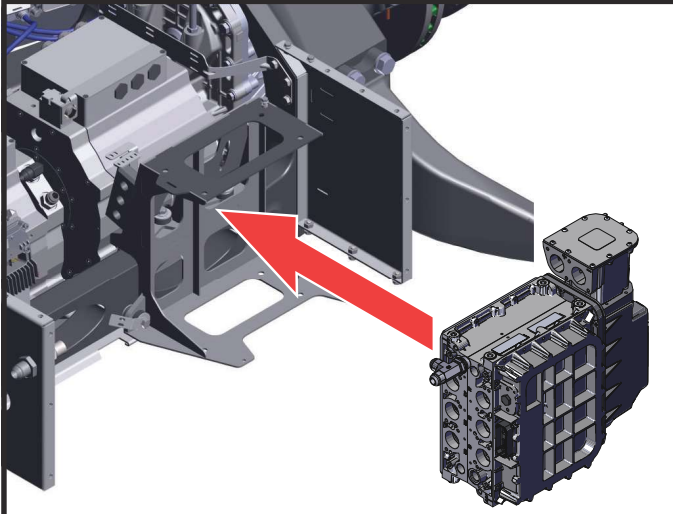


Figure 11-25. Dual Inverter Removal and Replacement - 1 of 2

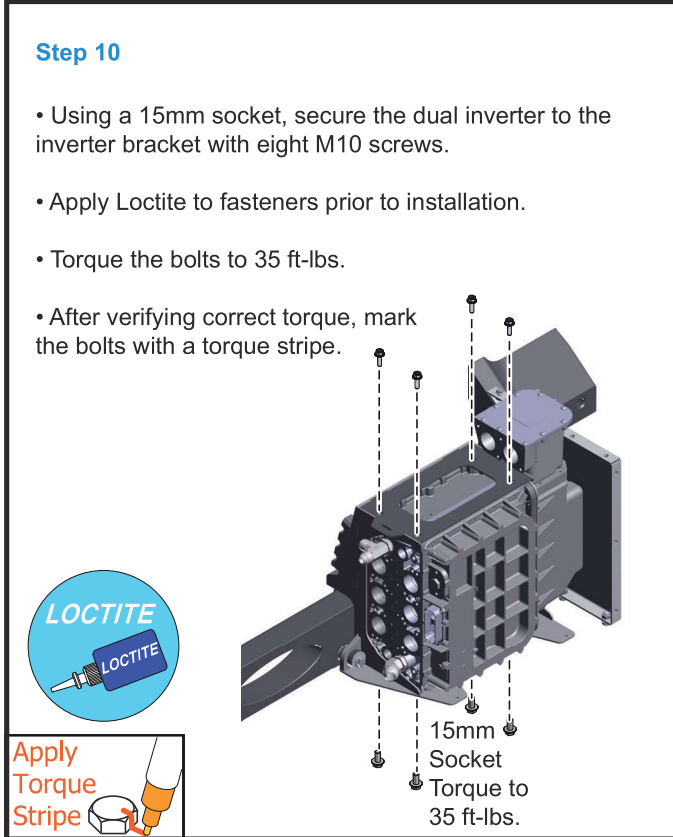


**Step 9**

- Use approved lifting techniques to slide the replacement dual inverter into the inverter bracket.

**Step 10**

- Using a 15mm socket, secure the dual inverter to the inverter bracket with eight M10 screws.
- Apply Loctite to fasteners prior to installation.
- Torque the bolts to 35 ft-lbs.
- After verifying correct torque, mark the bolts with a torque stripe.

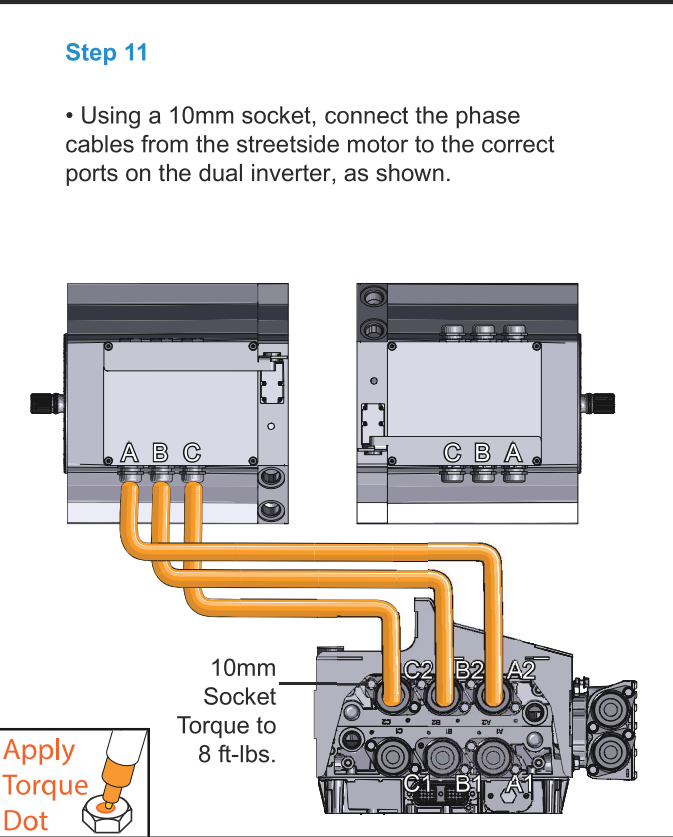


15mm Socket  
Torque to 35 ft-lbs.

Apply Torque Stripe

**Step 11**

- Using a 10mm socket, connect the phase cables from the streetside motor to the correct ports on the dual inverter, as shown.

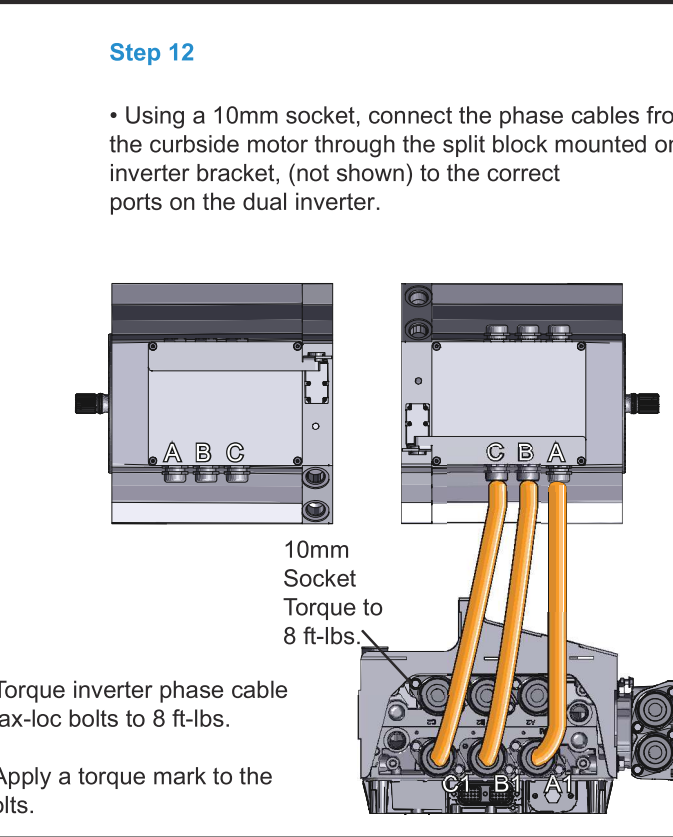


10mm Socket  
Torque to 8 ft-lbs.

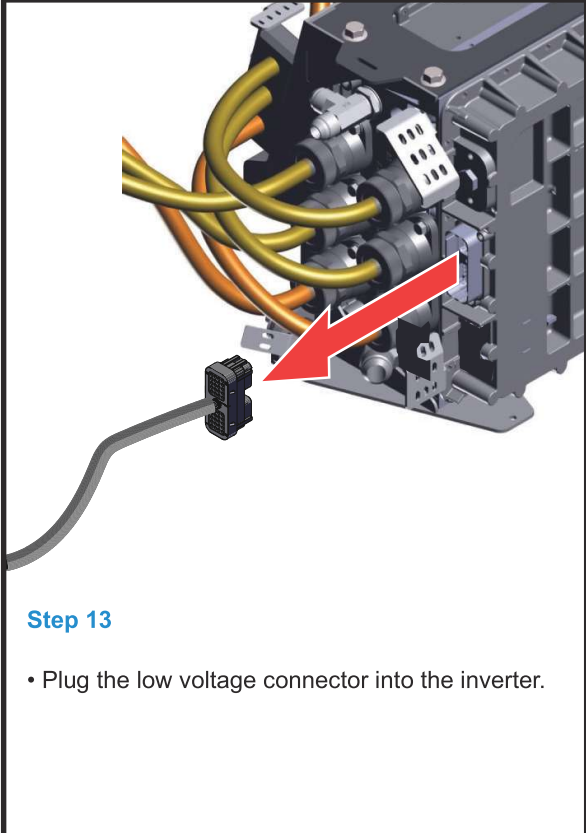
Apply Torque Dot

**Step 12**

- Using a 10mm socket, connect the phase cables from the curbside motor through the split block mounted on the inverter bracket, (not shown) to the correct ports on the dual inverter.
- Torque inverter phase cable max-loc bolts to 8 ft-lbs.
- Apply a torque mark to the bolts.

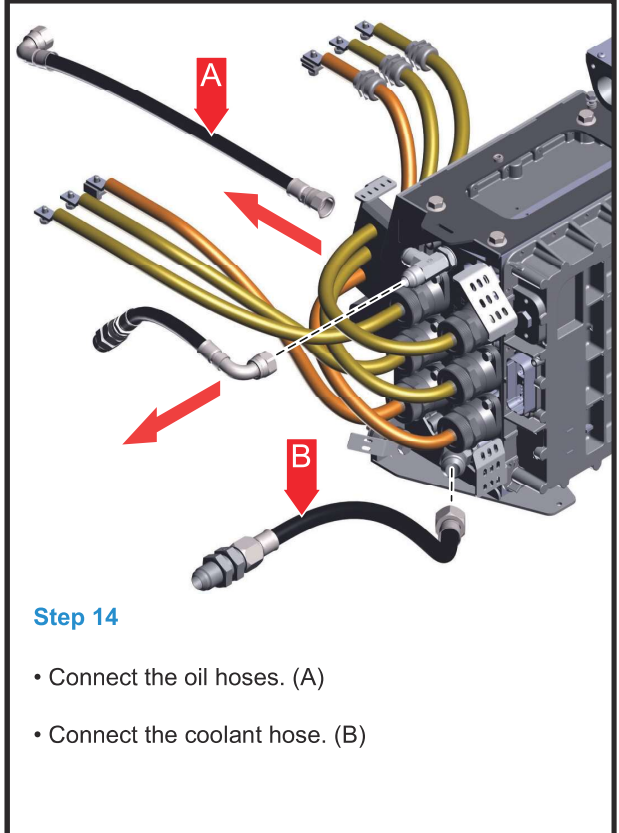


10mm Socket  
Torque to 8 ft-lbs.



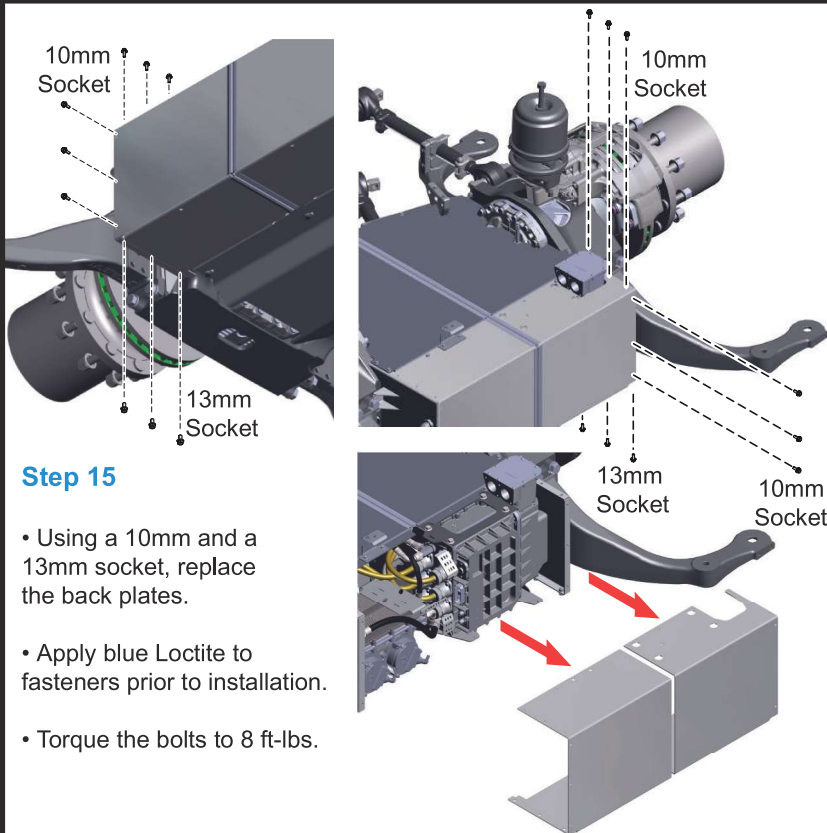
**Step 13**

- Plug the low voltage connector into the inverter.



**Step 14**

- Connect the oil hoses. (A)
- Connect the coolant hose. (B)

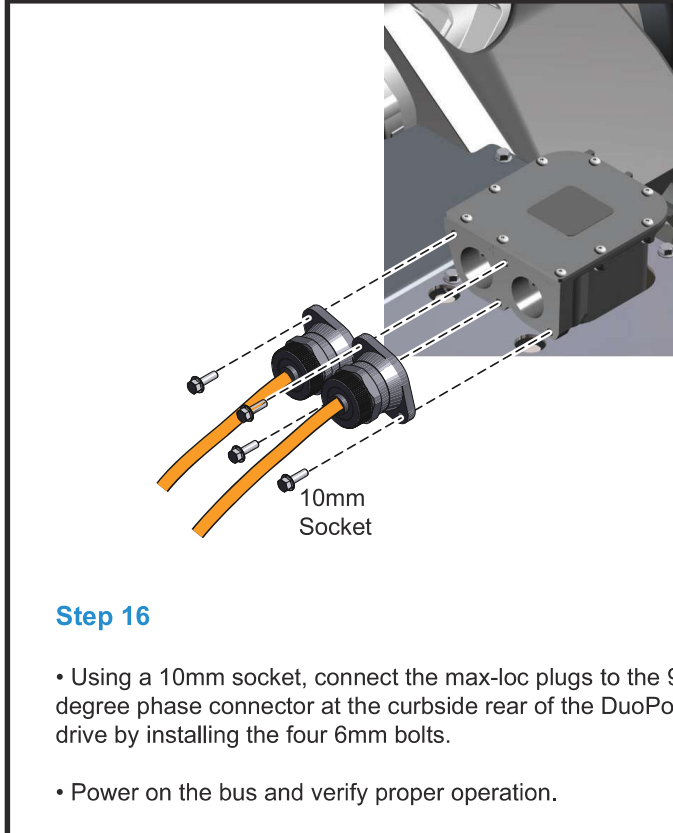


10mm Socket

13mm Socket

**Step 15**

- Using a 10mm and a 13mm socket, replace the back plates.
- Apply blue Loctite to fasteners prior to installation.
- Torque the bolts to 8 ft-lbs.



10mm Socket

**Step 16**

- Using a 10mm socket, connect the max-loc plugs to the 90 degree phase connector at the curbside rear of the DuoPower drive by installing the four 6mm bolts.
- Power on the bus and verify proper operation.

Figure 11-26. Dual Inverter Removal and Replacement - 2 of 2

## Oil Pump Module Technical Specifications

---

*Table 11-4: Oil Pump Module Technical Specifications - Single pump*

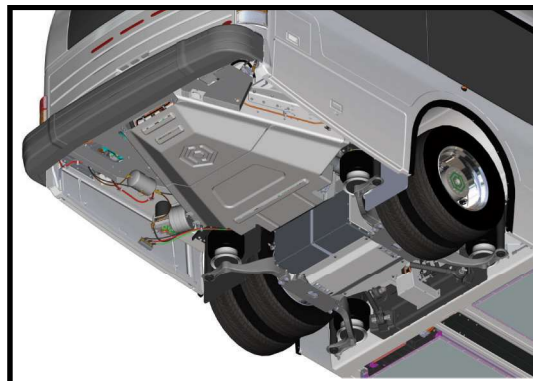
Parameter	Specification
Theoretical Displacement:	0.192 in <sup>3</sup> /rev (3.14 cc/rev)
Flow Capacity Maximum:	4.0 gal/min (15 L/min)
Operating Pressure Maximum:	100 psi (6.9 Bar)
Motor Speed Maximum:	5000 rev/min
Motor Speed Minimum:	500 rev/min
Motor Speed Default:	4000 rev/min (configurable)
Input Voltage:	18-32 Vdc (28 nominal)
Operating Current Draw Maximum:	25 A
Thermal Protection:	Auto self protect shutdown - 266° F (130° C)

## Oil Pump Module Removal and Replacement

---

To remove the Oil Pump Module from the DuoPower frame, the following tools are recommended:

- 5mm Allen Wrench
- 10mm Socket/Ratchet
- 13mm Socket/Ratchet
- Loctite 243
- Torque Wrench (rated for 5 ft-lb to 40 ft-lb)
- Torque Paint



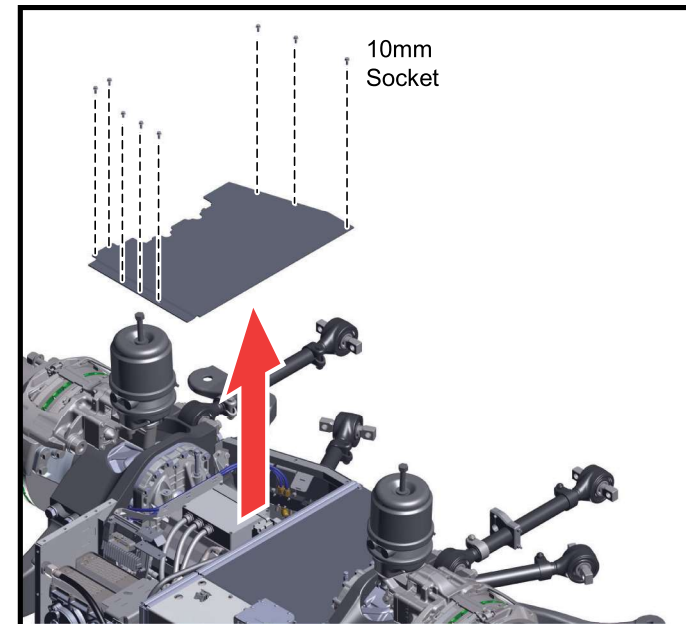
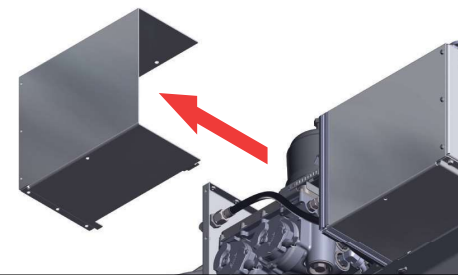
**Step 1**

- Power down the bus.
- Perform lock-out/tag-out.
- The oil module is located on the streetside rear of the DuoPower drive.



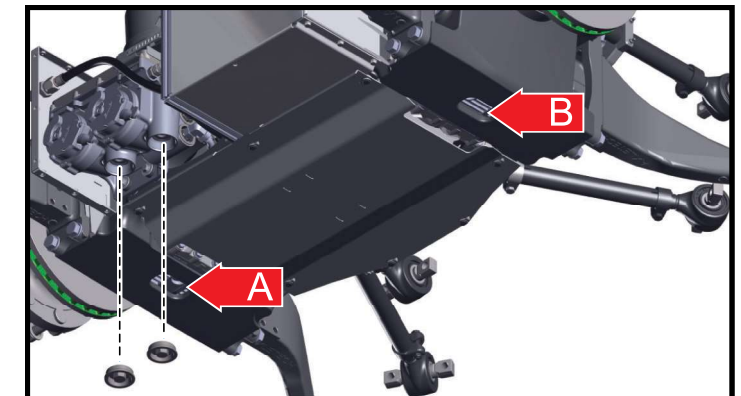
**Step 2**

- Using a 10mm and 13mm socket, remove the six M6 bolts that secure the streetside backplate cover.



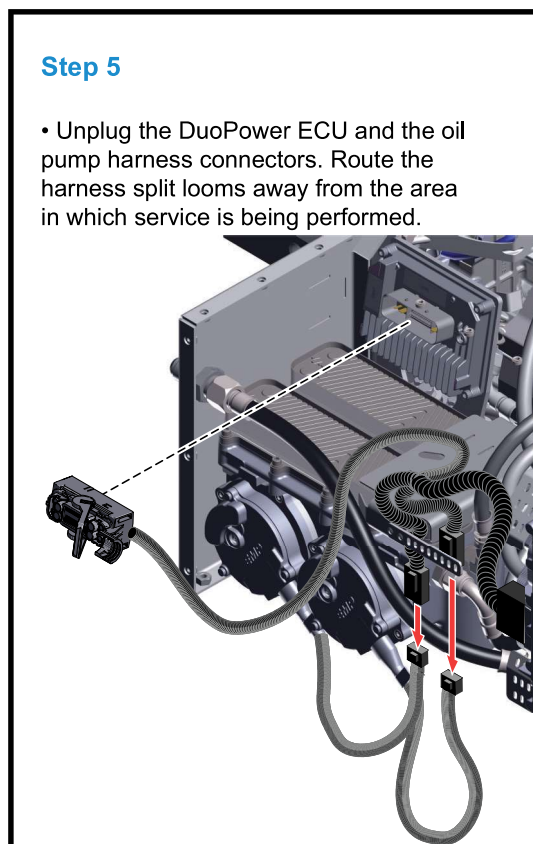
**Step 3**

- Using a 10mm socket, remove the bolts that secure the curbside top plate to the DuoPower enclosure.



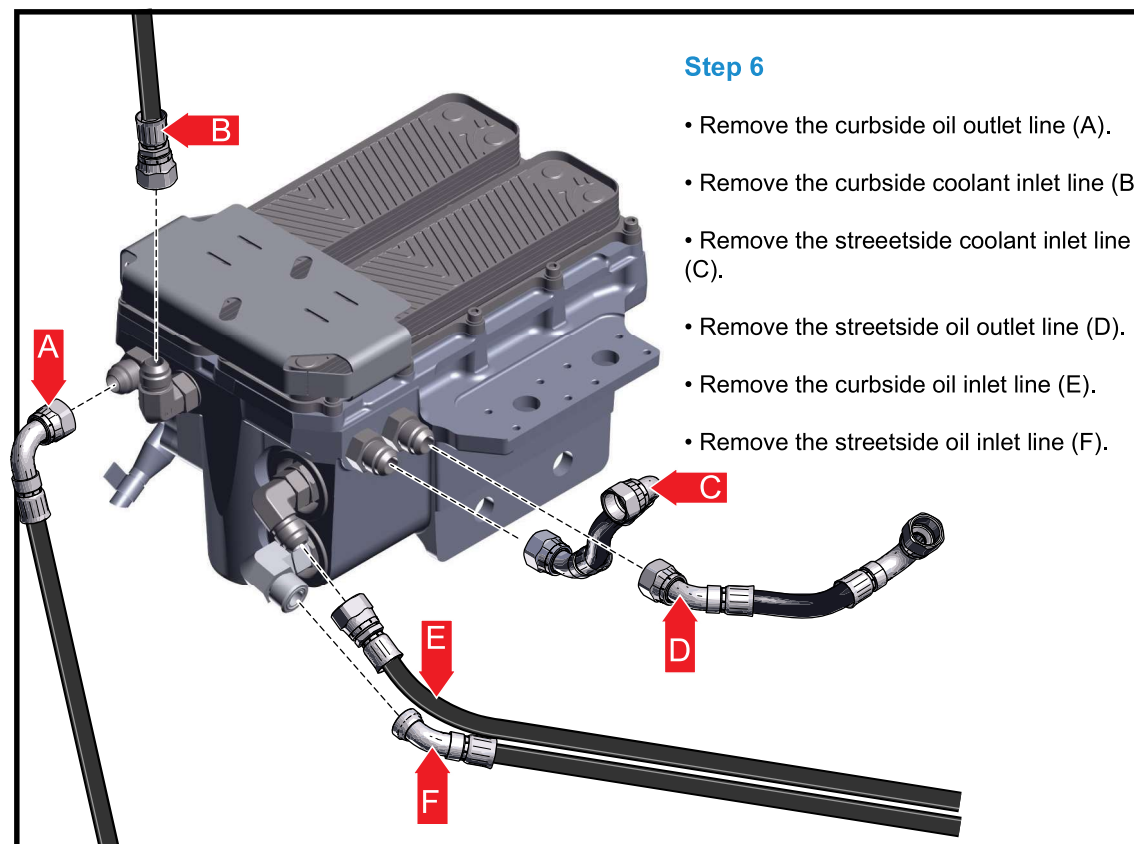
**Step 4**

- Drain gearbox oil by opening the streetside and curbside gearbox sumps (A & B). Capture the draining oil in an appropriate container.
- Drain the DuoPower coolant loop by removing the coolant pump filters and allowing the pumps to drain into a catch pan.



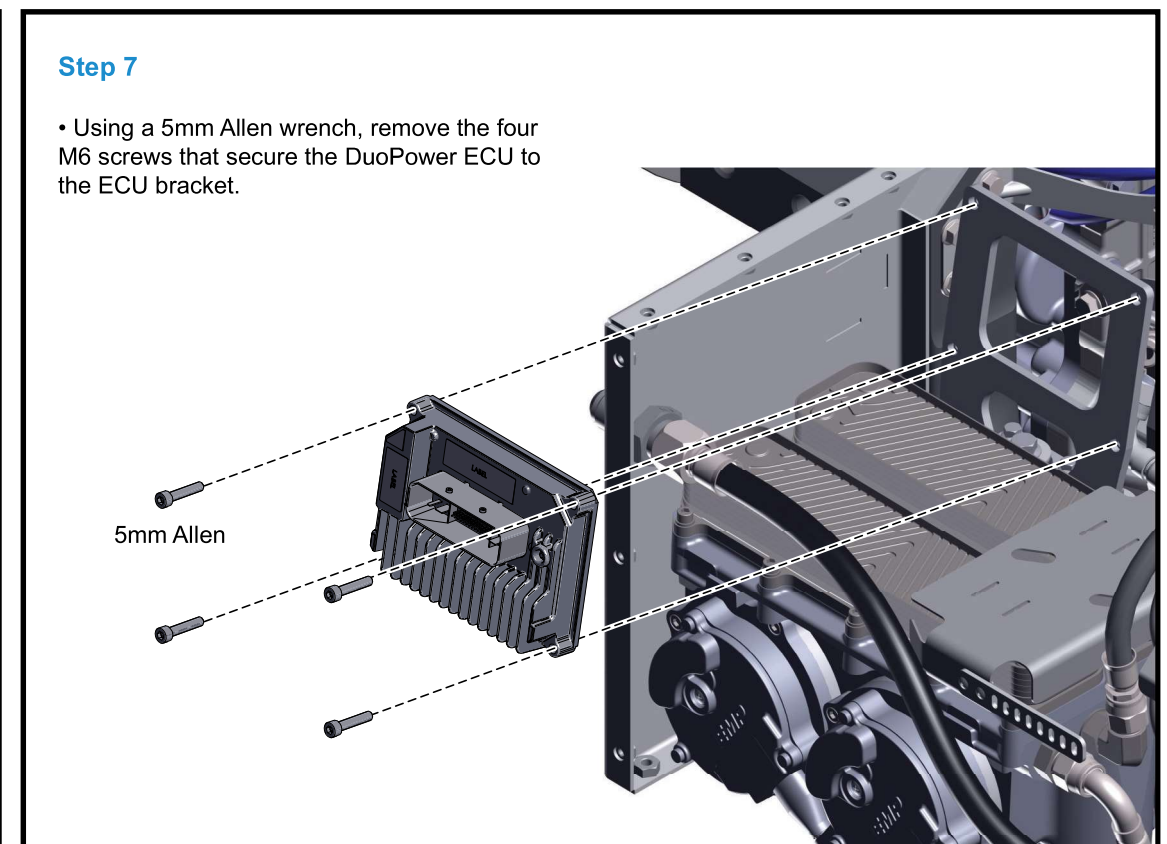
**Step 5**

- Unplug the DuoPower ECU and the oil pump harness connectors. Route the harness split looms away from the area in which service is being performed.



**Step 6**

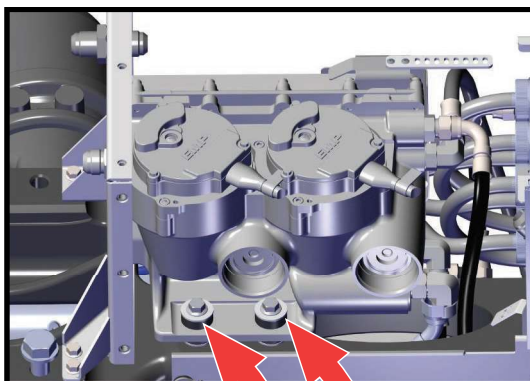
- Remove the curbside oil outlet line (A).
- Remove the curbside coolant inlet line (B).
- Remove the streetside coolant inlet line (C).
- Remove the streetside oil outlet line (D).
- Remove the curbside oil inlet line (E).
- Remove the streetside oil inlet line (F).



**Step 7**

- Using a 5mm Allen wrench, remove the four M6 screws that secure the DuoPower ECU to the ECU bracket.

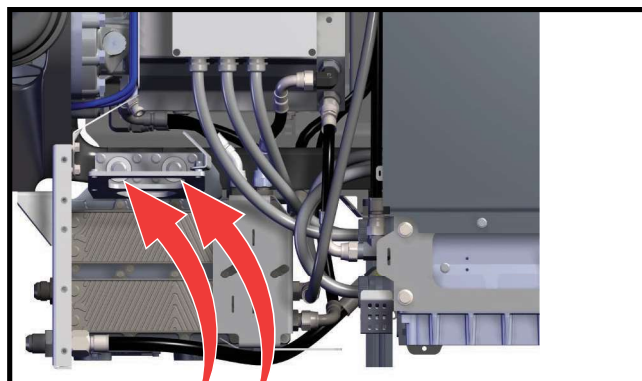
Figure 11-27. Oil Pump Module Removal and Replacement - 1 of 2



**Step 8**

- Using a XXmm, remove the M10 hex head flange bolts, washers, and the two isolators that secure the base of the oil module to the DuoPower frame.

Note: There are washers on both sides of the isolators.



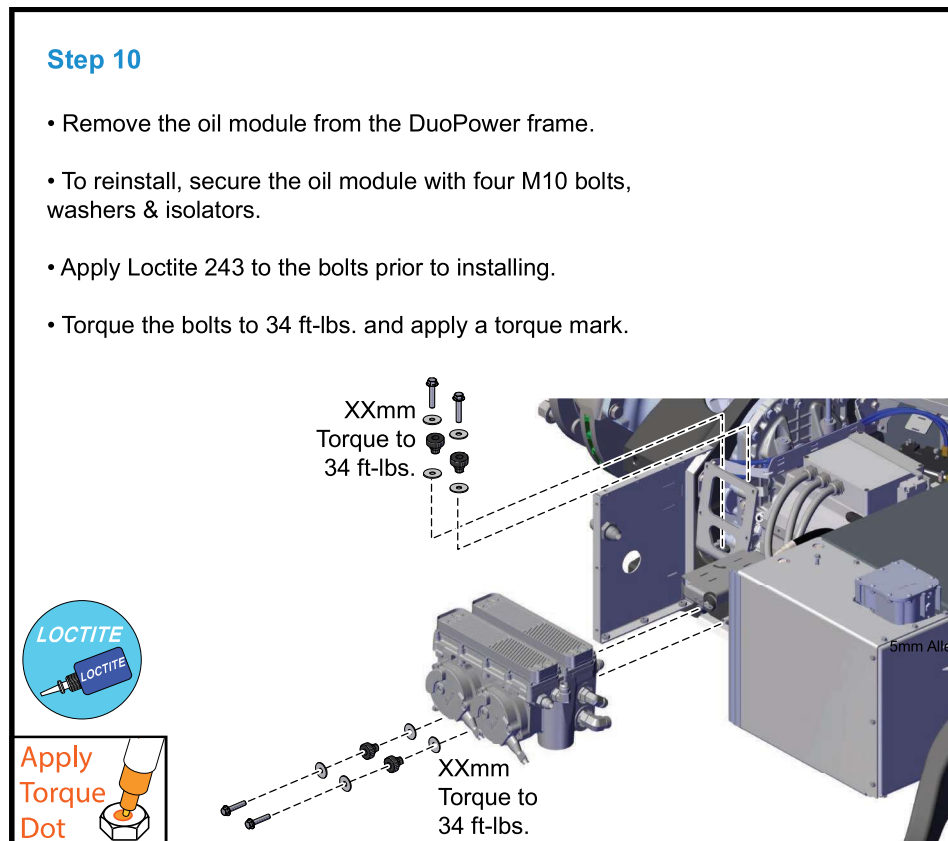
**Step 9**

- Using a XXmm, remove the M10 hex head flange bolts, washers and isolators that secure the top of the oil module to the frame.

Note: There are washers on both sides of the isolators.

**Step 10**

- Remove the oil module from the DuoPower frame.
- To reinstall, secure the oil module with four M10 bolts, washers & isolators.
- Apply Loctite 243 to the bolts prior to installing.
- Torque the bolts to 34 ft-lbs. and apply a torque mark.



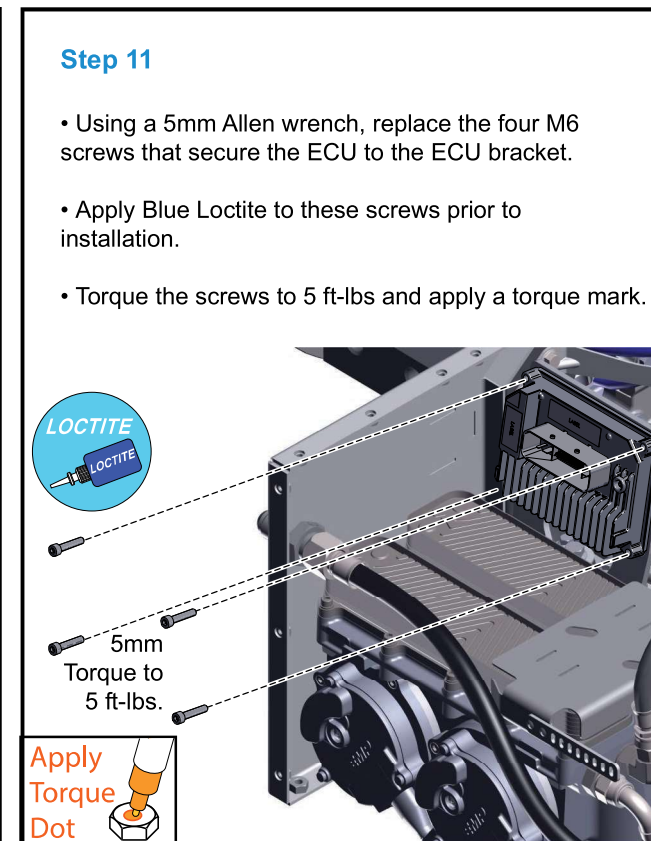
XXmm Torque to 34 ft-lbs.

LOCTITE

Apply Torque Dot

**Step 11**

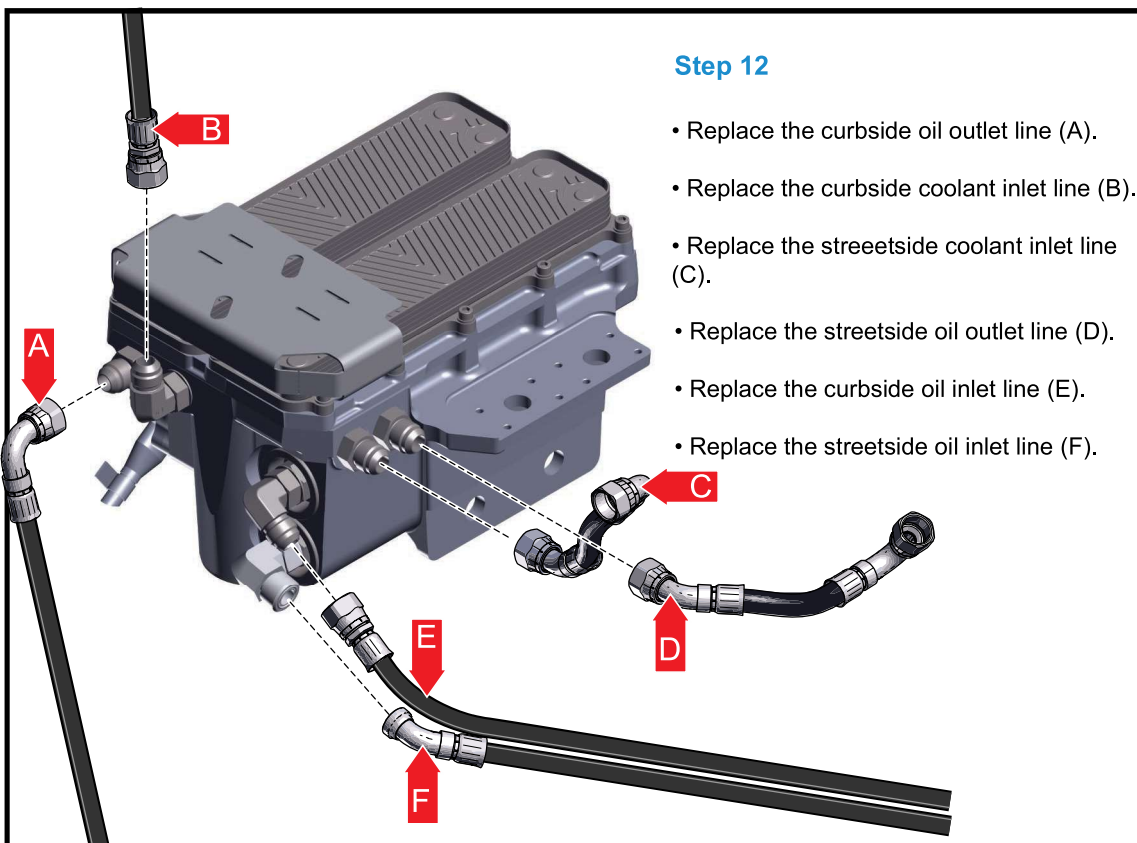
- Using a 5mm Allen wrench, replace the four M6 screws that secure the ECU to the ECU bracket.
- Apply Blue Loctite to these screws prior to installation.
- Torque the screws to 5 ft-lbs and apply a torque mark.



LOCTITE

5mm Torque to 5 ft-lbs.

Apply Torque Dot

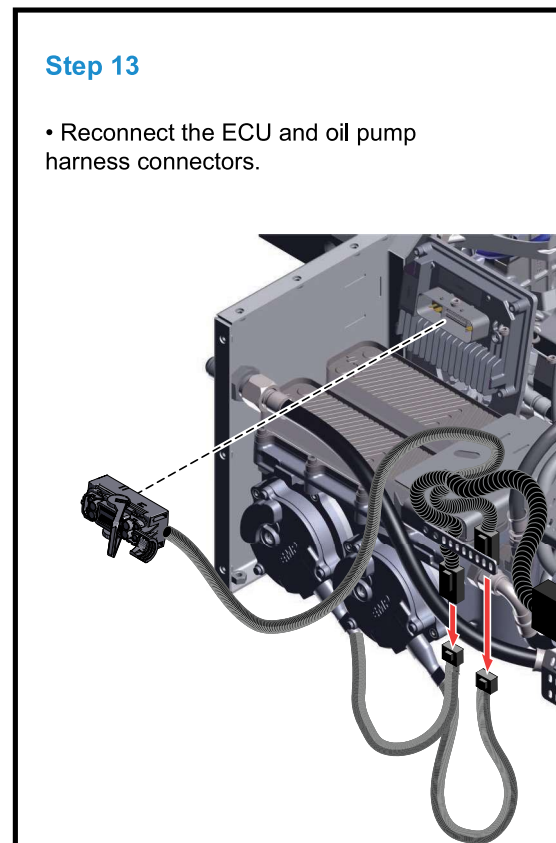


**Step 12**

- Replace the curbside oil outlet line (A).
- Replace the curbside coolant inlet line (B).
- Replace the streetside coolant inlet line (C).
- Replace the streetside oil outlet line (D).
- Replace the curbside oil inlet line (E).
- Replace the streetside oil inlet line (F).

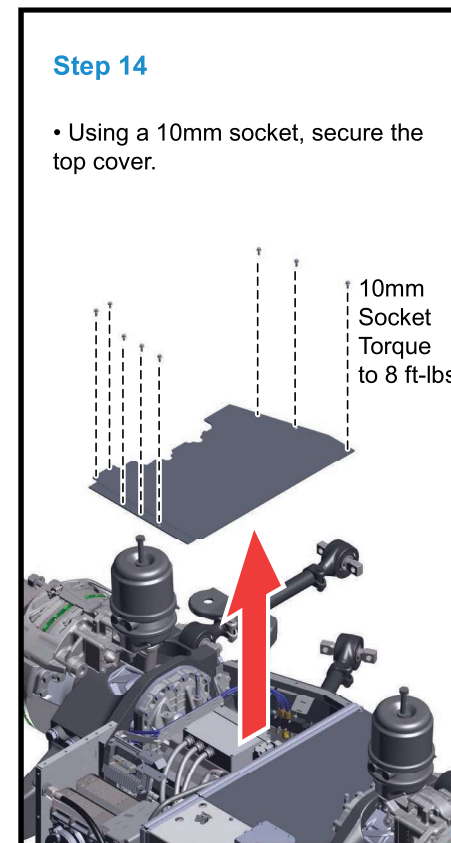
**Step 13**

- Reconnect the ECU and oil pump harness connectors.

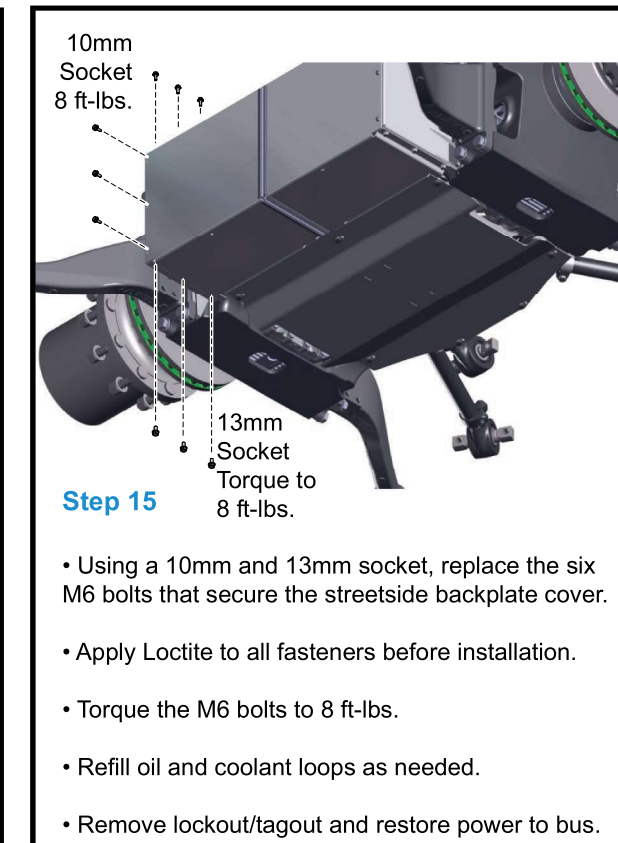


**Step 14**

- Using a 10mm socket, secure the top cover.



10mm Socket Torque to 8 ft-lbs.



**Step 15**

- Using a 10mm and 13mm socket, replace the six M6 bolts that secure the streetside backplate cover.
- Apply Loctite to all fasteners before installation.
- Torque the M6 bolts to 8 ft-lbs.
- Refill oil and coolant loops as needed.
- Remove lockout/tagout and restore power to bus.

10mm Socket Torque to 8 ft-lbs.

13mm Socket Torque to 8 ft-lbs.

Figure 11-28. Oil Pump Module Removal and Replacement - 2 of 2

## DuoPower Traction Motor/Dual Inverter Pairing Procedures

The DuoPower Axle uses two Traction Motors and a Dual Inverter to provide propulsion power for the vehicle. Whenever one of these components is removed from the DuoPower axle, the following pairing procedure **MUST** be performed to synchronize the motors with the inverter.

**Note:** This includes removal of a Traction Motor to service a Gearbox.



If a Traction Motor or Dual Inverter is replaced **AT ANY TIME**, you must perform the *Traction Motor/Dual Inverter Pairing Procedure* detailed here.

To pair (synchronize) the Traction Motor(s) and Dual Inverter, perform the following:

1. In the Driver's Workplace, turn the master Switch to the OFF position.



**Figure 11-29. Driver Workplace Master Switch OFF**

2. Open the Streetside wheel Well Box and connect the Service laptop to the OBD2 port with the USB-Link Tool as shown below.



**Figure 11-30. Connecting the Laptop to OBD2 Port**

3. In the Driver's Workplace, turn the master Switch to the ACC position.



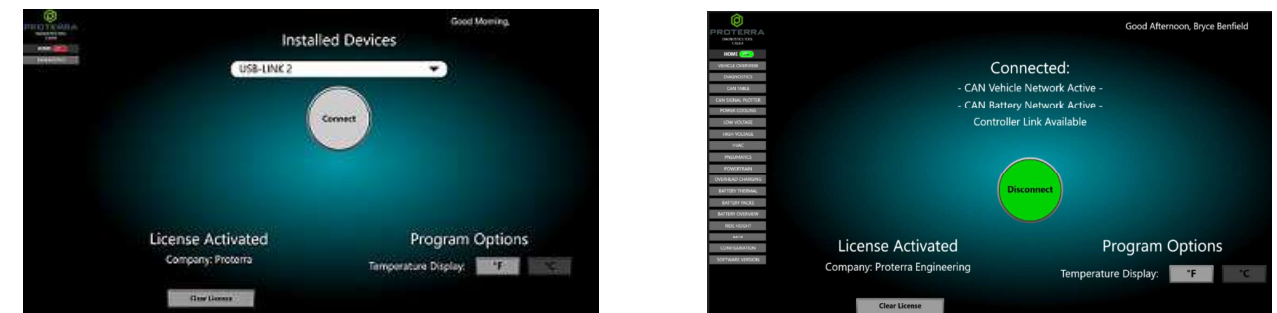
**Figure 11-31. Driver Workplace Master Switch in ACC**

4. On the Service laptop, double-click the Proterra Diagnostic Tool icon to open the software.



**Figure 11-32. Proterra Diagnostic Tool Icon**

5. Allow the software to open and then select the USB Link in the interface and click the **Connect** button. The "Connected" screen will appear.



**Figure 11-33. Proterra Diagnostic Tool - Connected**

- Click on the POWERTRAIN selection in the left menu. The “Powertrain” screen will appear.

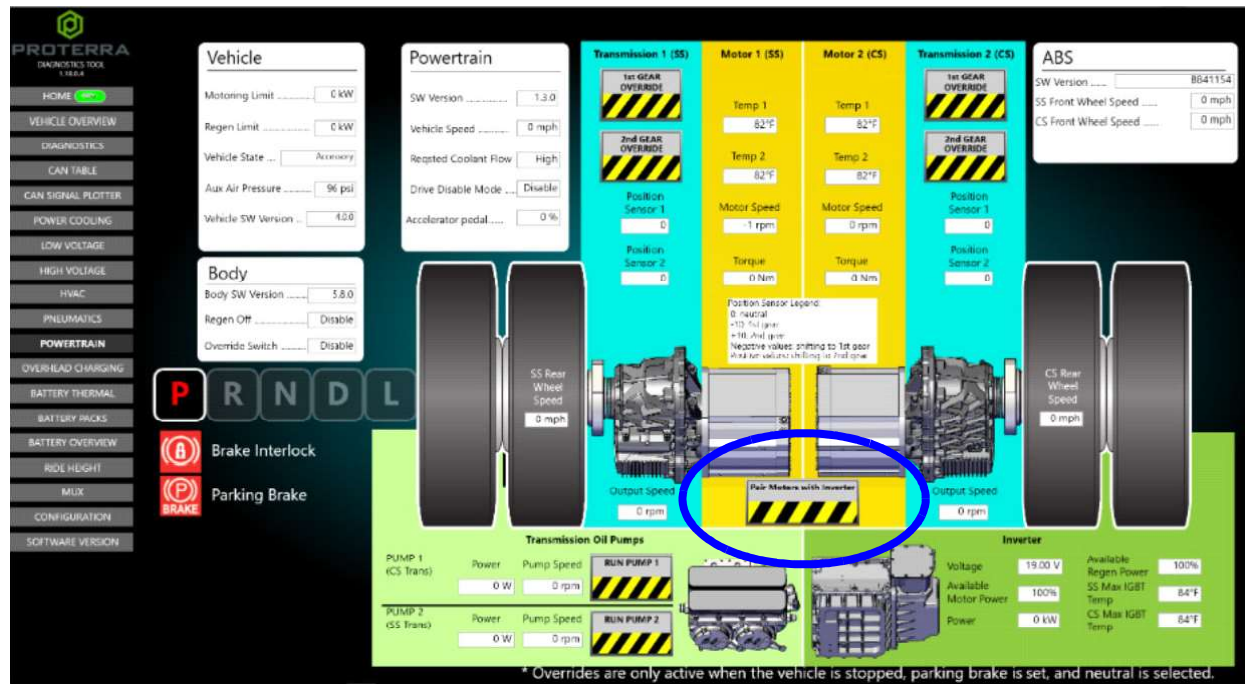


Figure 11-34. Proterra Diagnostic Tool - Powertrain Screen

- Click on the **Pair Motors with Inverter** selection in the center area of the Powertrain screen (Circled in BLUE above), and the following pop-up message will be displayed.

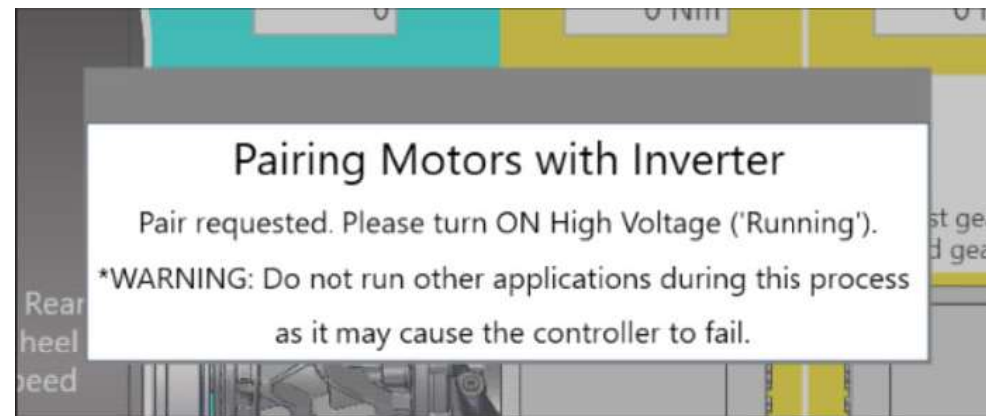


Figure 11-35. Pairing Motors with Inverter Pop-Up Message 1

- In the Driver's Workplace, turn the master Switch to the ON position.



Figure 11-36. Driver Workplace Master Switch in ON

- Once the ON position is selected, the following pop-up message appears on the Powertrain screen. Wait until this message goes away.

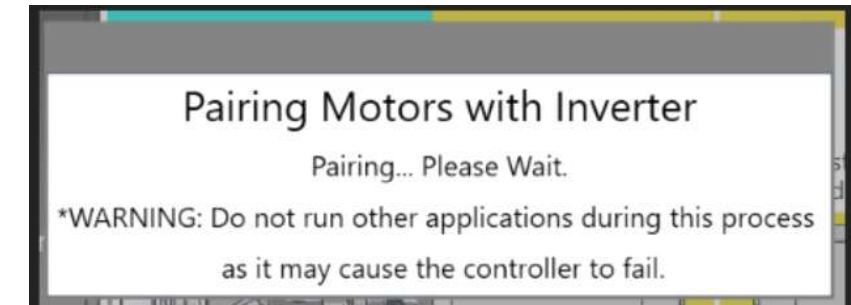


Figure 11-37. Pairing Motors with Inverter Pop-Up Message 2

- When the pairing process is complete an audible chirp will be heard from each inverter. Verify the “Pairing Successful” message is displayed and click “OK”.

**NOTICE!** If the “Pairing Failed” message is displayed, click OK, verify the vehicle is ON and repeat the pairing attempt. Contact Proterra Service if the pairing process continues to fail..

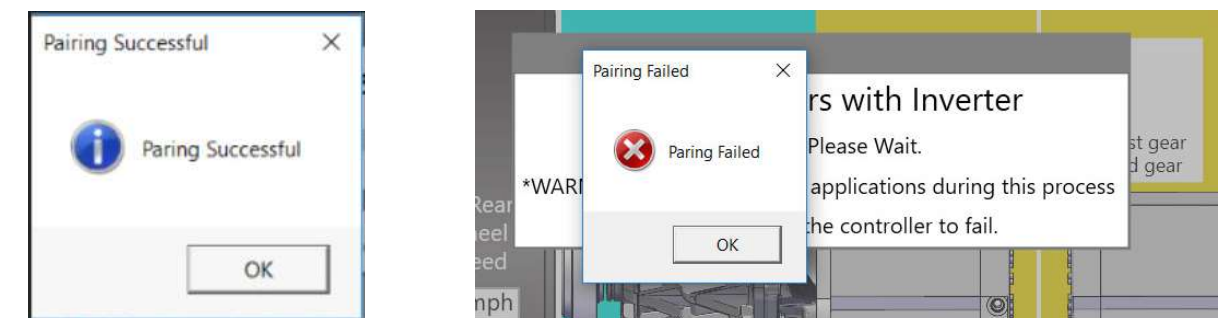
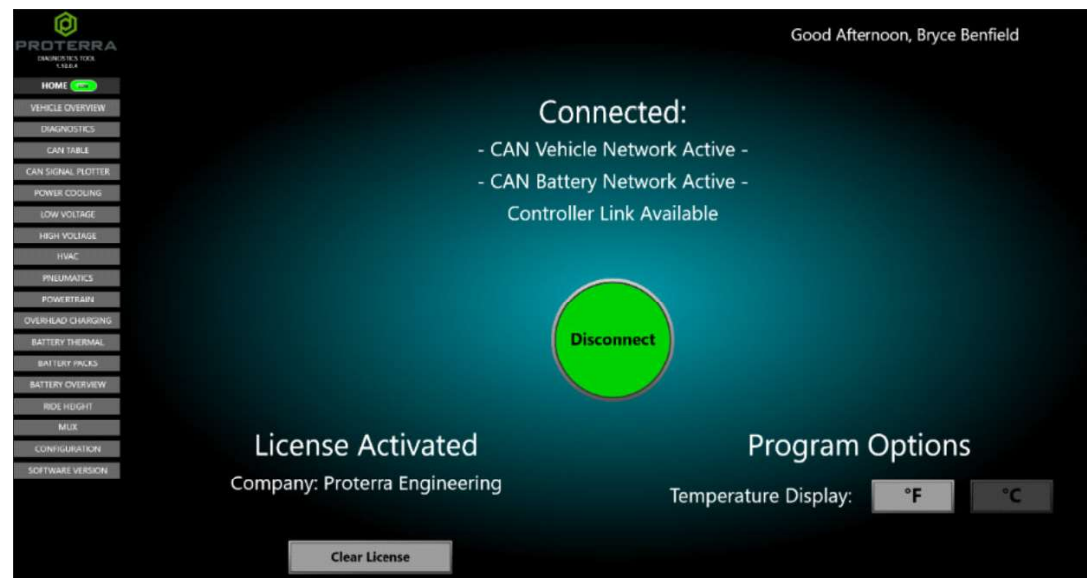


Figure 11-38. Pairing Successful/Pairing Failed Pop-Up message

11. After successful pairing and clicking OK, the HOME screen will be displayed. Click the “Disconnect” button.



**Figure 11-39. Proterra Diagnostic Tool - Home Screen**

12. Disconnect the Service laptop, with the USB-Link Tool, from the OBD2 port.



**Figure 11-40. Connecting the Laptop to OBD2 Port**

13. Close the Streetside wheel well box and verify proper operation of the DuoPower axle.
14. After testing for proper operation, return the vehicle to service.

## DuoPower Axle Brake Service Procedures

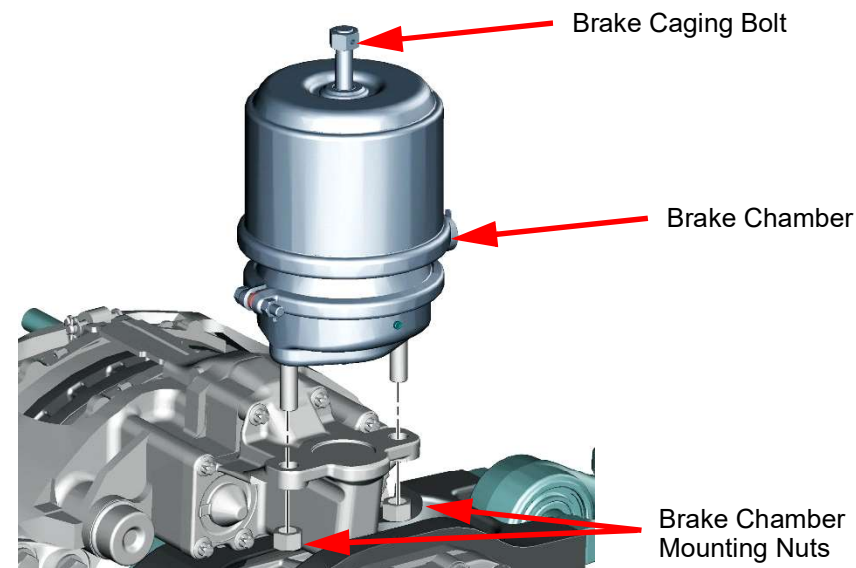
The DuoPower Axle uses two Bendix (Knorr-Bremse) SB7 Brake assemblies mounted at the wheel ends. The following procedures for servicing the DuoPower Brakes are covered:

- Brake Chamber Removal and Replacement
- Brake Pad Removal and Replacement
- Anti-Lock Brake System (ABS) Sensor Removal and Replacement
- Brake Caliper/Carrier Removal and Replacement

## Brake Chamber Removal and Replacement

To remove and replace a Brake Chamber, perform the following:

1. Cage the parking brake chamber.
2. Label and then disconnect the air lines from the brake chamber.
3. Using a 24mm socket, remove the nuts and the brake chamber.



**Figure 11-41. Removing the Brake Chamber**

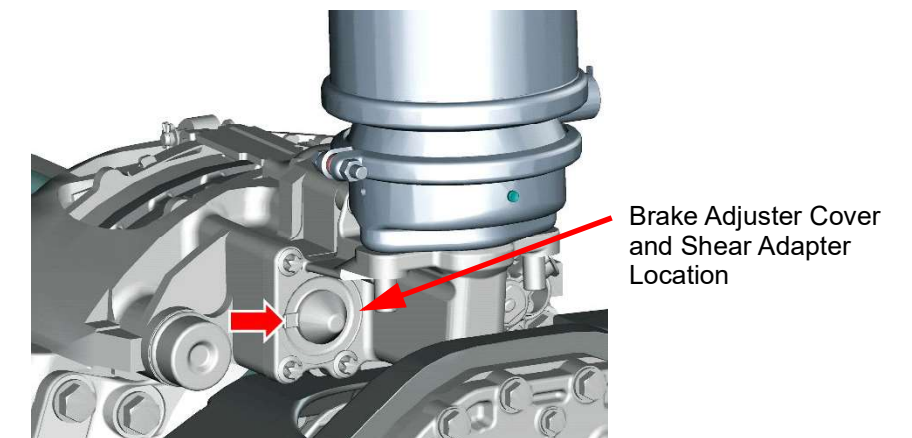
4. Install the replacement brake chamber, ensuring proper orientation of the air line connections.
5. Using a 24mm socket, install the nuts. **Torque to 144 ft-lbs (195 Nm).**
6. Connect the air lines to the proper brake chamber port.
7. Release (un-cage) the parking brake chamber.
8. Test for proper operation and return the vehicle to service.

## Brake Pad Removal and Replacement

To remove and replace brake pads, perform the following:

**IMPORTANT!** Replace all brake pads on the axle when performing this procedure.

1. Chock the wheels and release the parking brake.
2. Raise and properly support the vehicle using jack stands.
3. Remove the wheels and tires from the side of the axle being serviced.
4. Remove the brake adjuster cover and place aside.

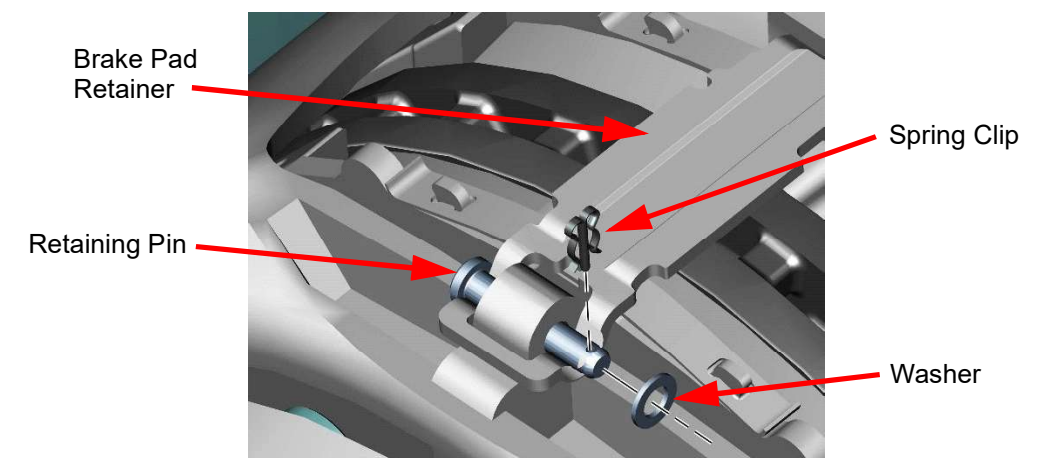


**Figure 11-42. Removing the Brake Adjuster Cover**

5. Using the shear adapter, back off the brakes.

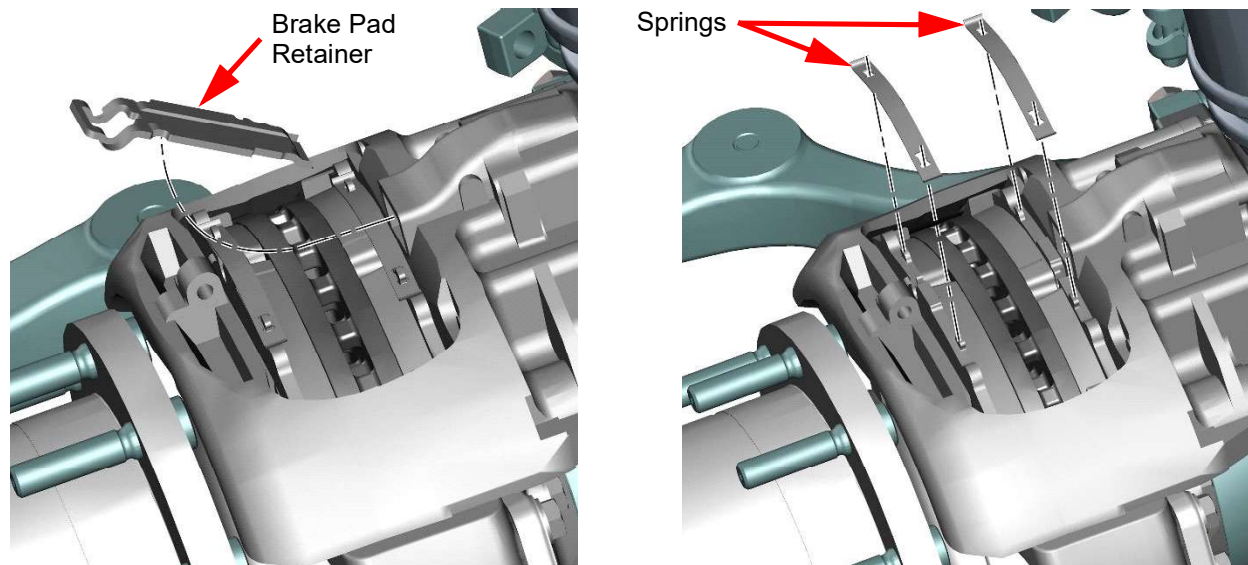
**NOTICE!** If two shear adapters fail while attempting to back off the brakes, install a new brake caliper as internal damage may be present in the brake caliper.

6. Remove the spring clip, washer and the retaining pin from the brake pad retainer.



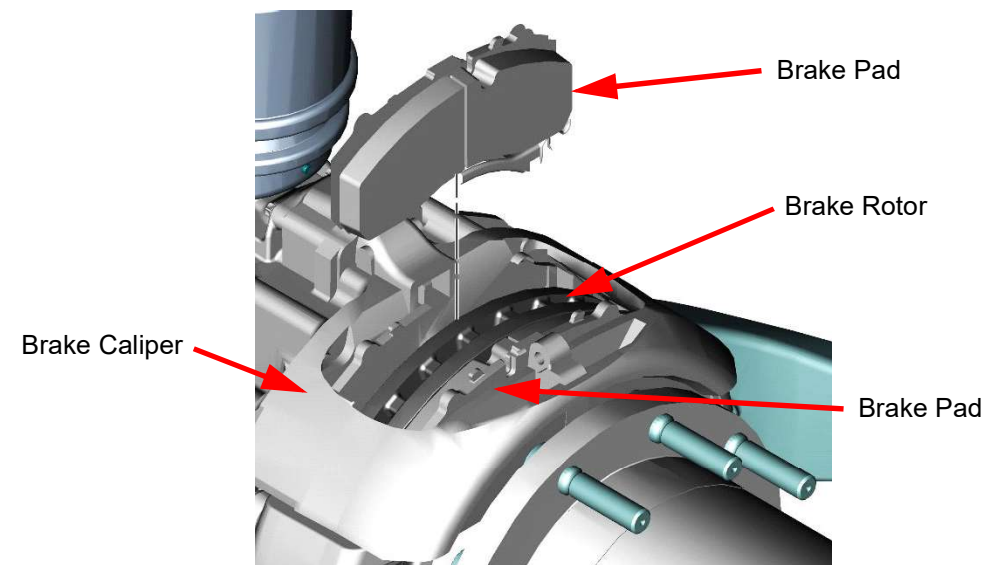
**Figure 11-43. Removing the Spring Clip, Washer, and Retaining Pin**

7. Remove the brake pad retainer and springs.



**Figure 11-44. Removing the Brake Pad Retainer and Springs**

8. Remove the brake pads from the caliper.

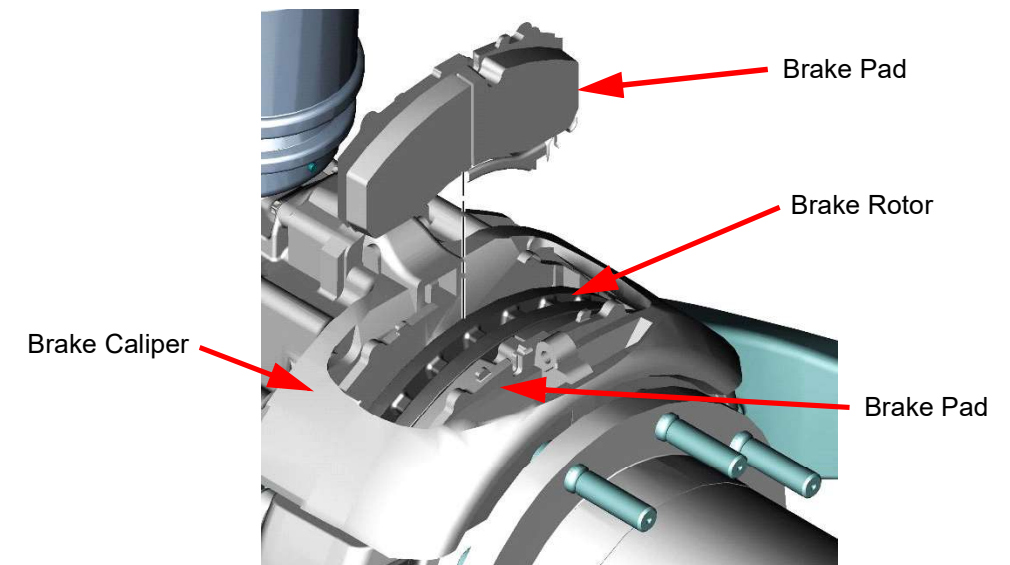


**Figure 11-45. Removing the Brake Pads**

9. Inspect the brake caliper for free travel and service as needed.

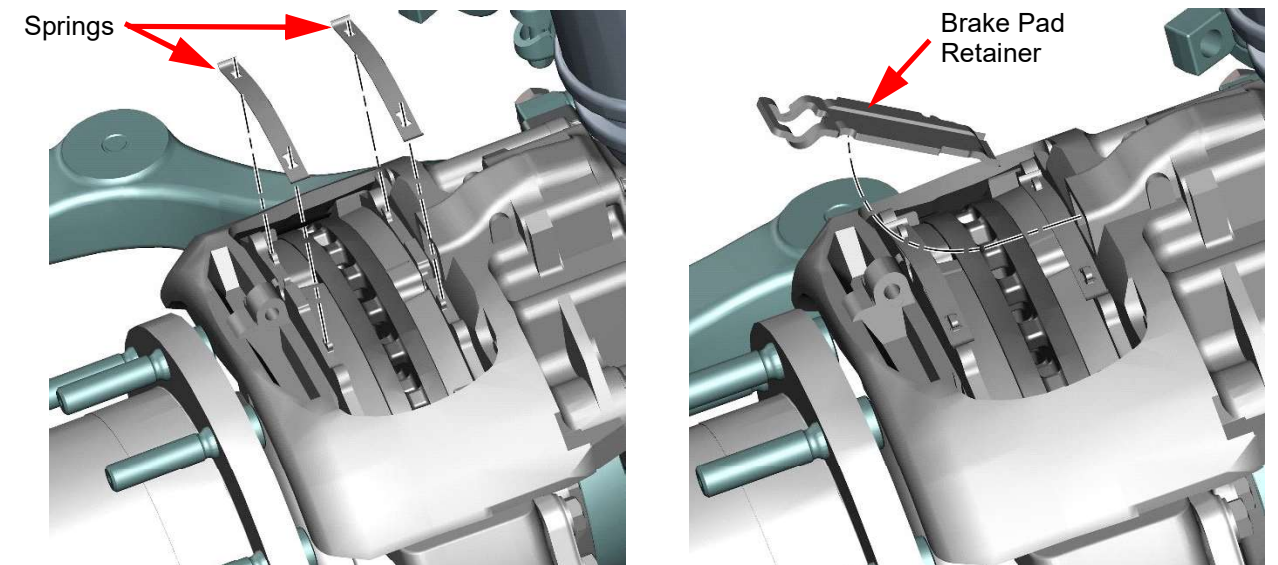
10. Inspect the brake rotor for wear and service as needed.

11. Install the new brake pads into the caliper.



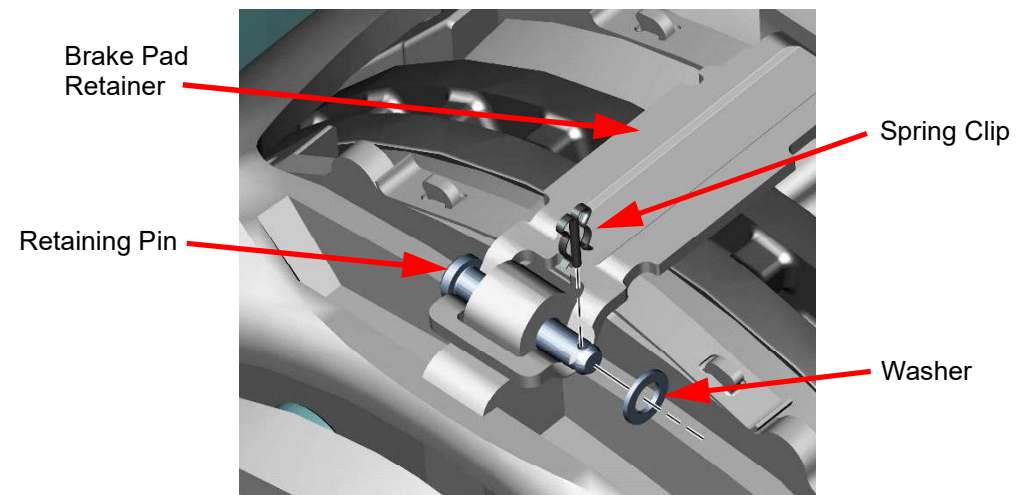
**Figure 11-46. Installing the Brake Pads**

12. Install the springs and the brake pad retainer.



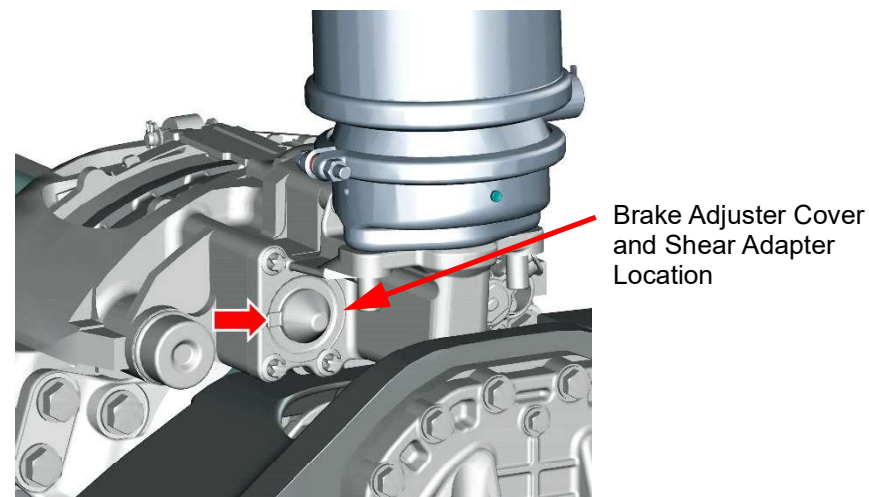
**Figure 11-47. Installing the Springs and Brake Pad Retainer**

13. Install the retaining pin, washer, and spring clip on the brake pad retainer.



**Figure 11-48. Installing the Retaining Pin, Washer, and Spring Clip**

14. Adjust the brakes until the brake pad comes in contact with the brake rotor, then back the adjuster back out three clicks.
15. Install the brake adjuster cover.



**Figure 11-49. Installing the Brake Adjuster Cover**

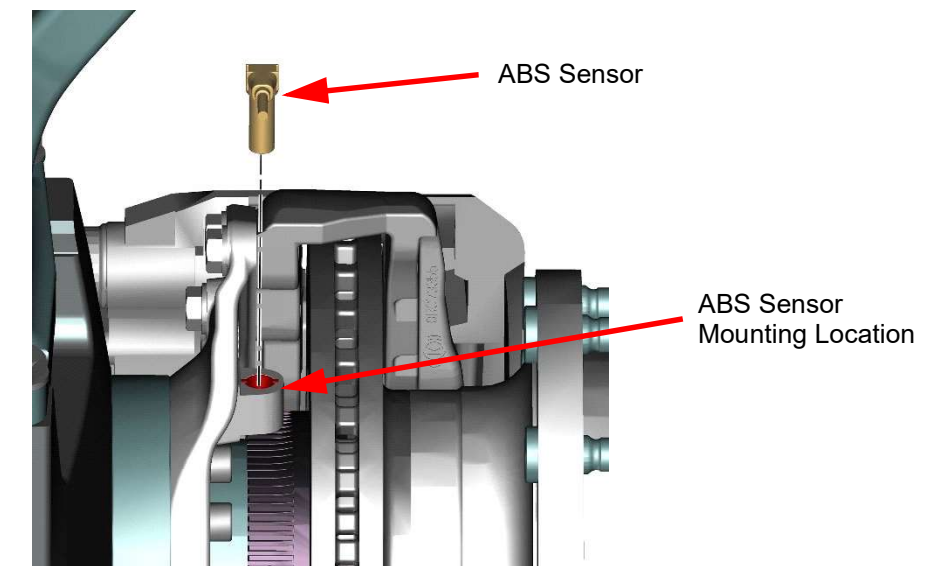
16. Install the wheels and tires onto the side of the axle being serviced.
17. Repeat the brake pad replacement steps for the opposite side of the axle.
18. Lower the vehicle off the jack stands and chock the wheels
19. Set the parking brake and remove the wheel chocks.
20. Test for proper brake operation and return the vehicle to service.

## Anti-Lock Brake System (ABS) Sensor Removal and Replacement

To remove and replace an ABS Sensor, perform the following:

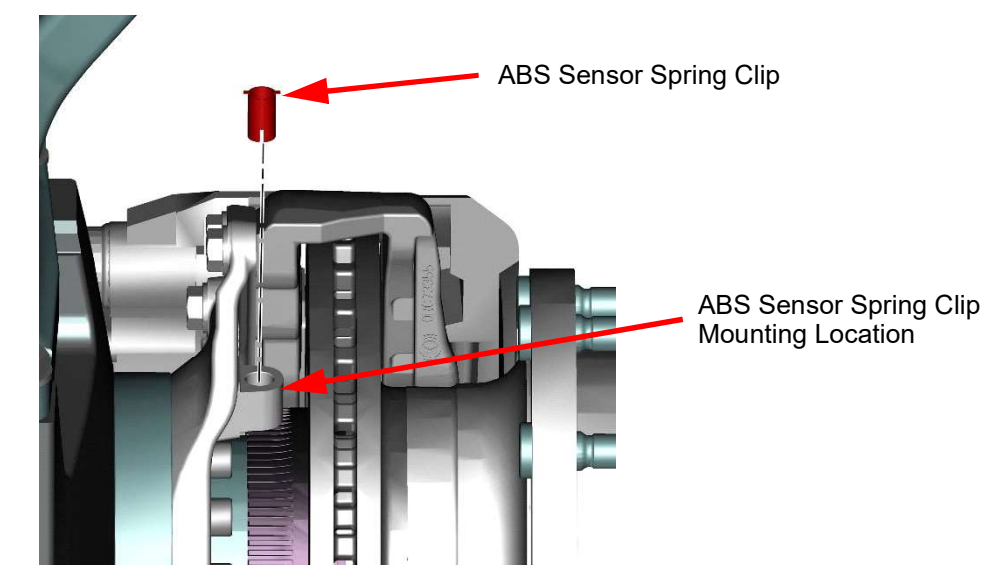
**IMPORTANT!** Replace the Spring Clip with the ABS Sensor when performing this procedure.

1. Disconnect the ABS (anti-lock brake system) electrical connector.
2. Remove the ABS sensor.



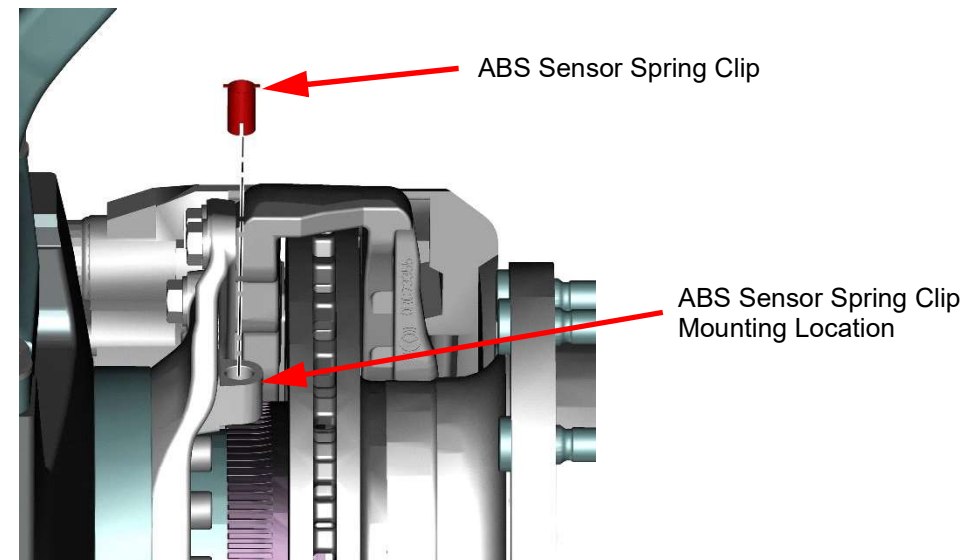
**Figure 11-50. Removing the ABS Sensor**

3. Remove and discard the ABS sensor spring clip.



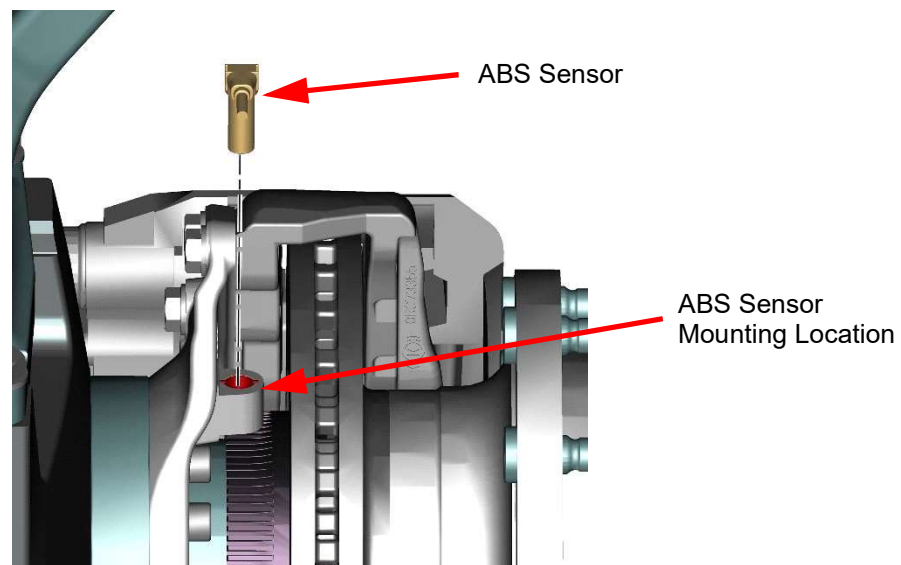
**Figure 11-51. Removing the ABS Sensor Spring Clip**

4. Install a new ABS sensor spring clip.



**Figure 11-52. Installing the ABS Sensor Spring Clip**

5. Install the replacement ABS sensor.



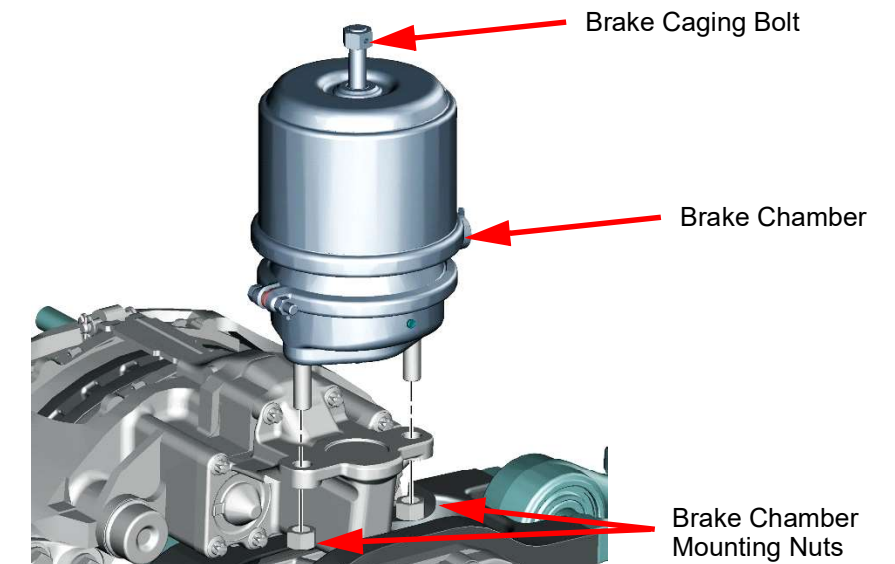
**Figure 11-53. Installing the ABS Sensor**

6. Connect the ABS Sensor electrical connector.
7. Test for proper ABS Sensor operation and return the vehicle to service.

## Brake Caliper/Carrier Removal and Replacement

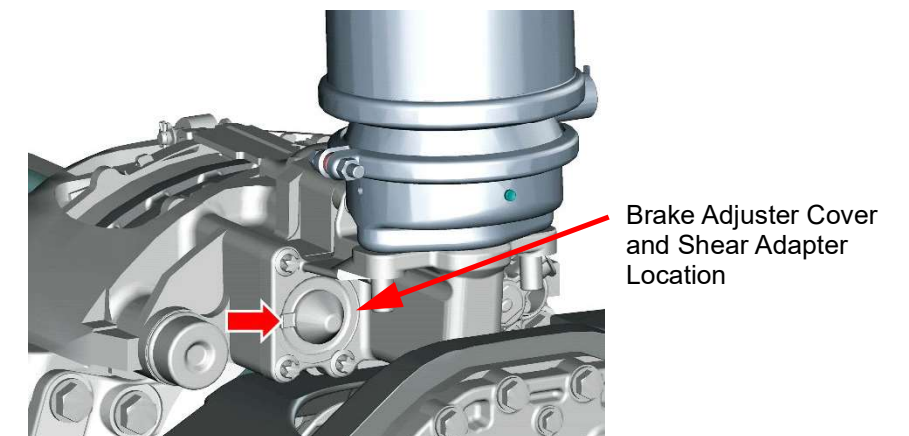
To remove and replace a Brake Caliper/Carrier, perform the following:

1. Raise and properly support the vehicle using jack stands.
2. Remove the wheels and tires from the side of the axle being serviced.
3. Cage the parking brake chamber.
4. Label and then disconnect the air lines from the brake chamber.
5. Using a 24mm socket, remove the nuts and the brake chamber.



**Figure 11-54. Removing the Brake Chamber**

6. Remove the brake adjuster cover and place aside.

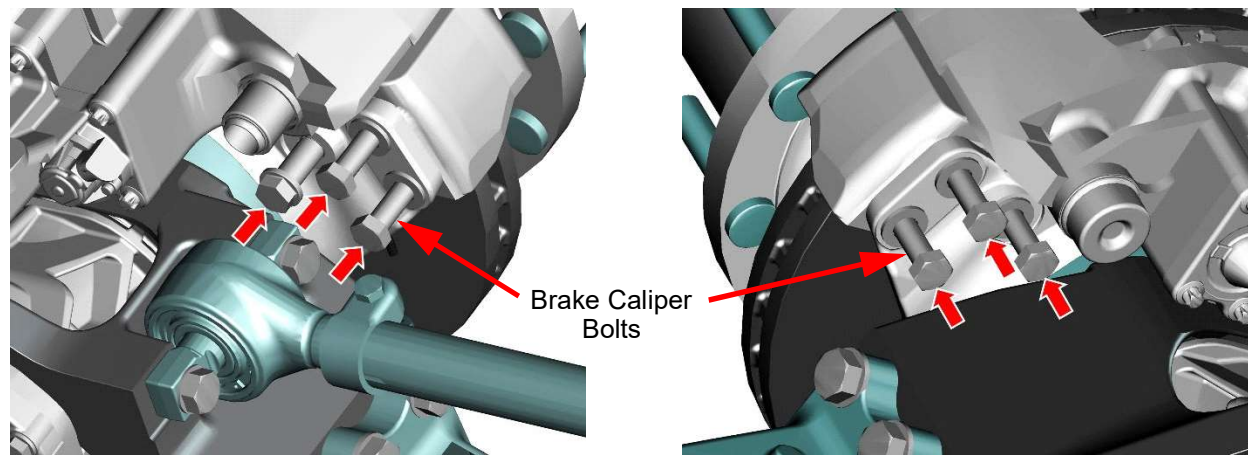


**Figure 11-55. Removing the Brake Adjuster Cover**

7. Using the shear adapter, back off the brakes.

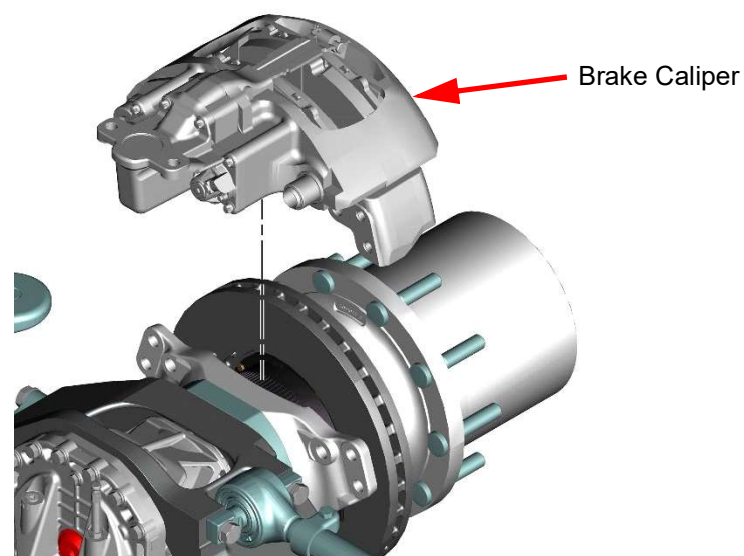
**NOTICE!** If two shear adapters fail while attempting to back off the brakes, install a new brake caliper as internal damage may be present in the brake caliper.

8. Disconnect the brake lining wear sensor electrical connector.
9. Using the dog bone tool TC-80411, remove the brake caliper bolts.
  - a. Shoulder pin bolt: M16x1.50x58/19-10.9 HHCS (no washer, qty. 1)
  - b. Inner bolt: M16x1.50x60/35-10.9 (qty. 1)
  - c. Outer bolts: M16x1.50x45/45-10.9 PHOS (qty. 4)



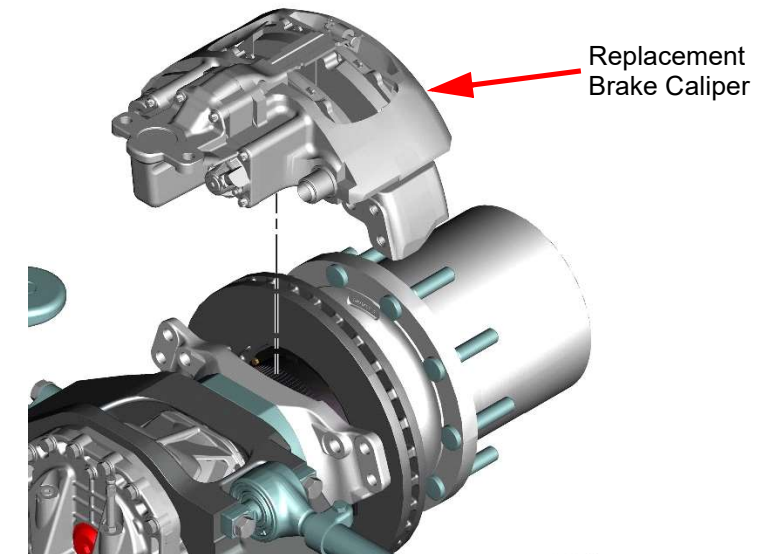
**Figure 11-56. Removing the Brake Caliper Bolts**

10. Remove the brake caliper.



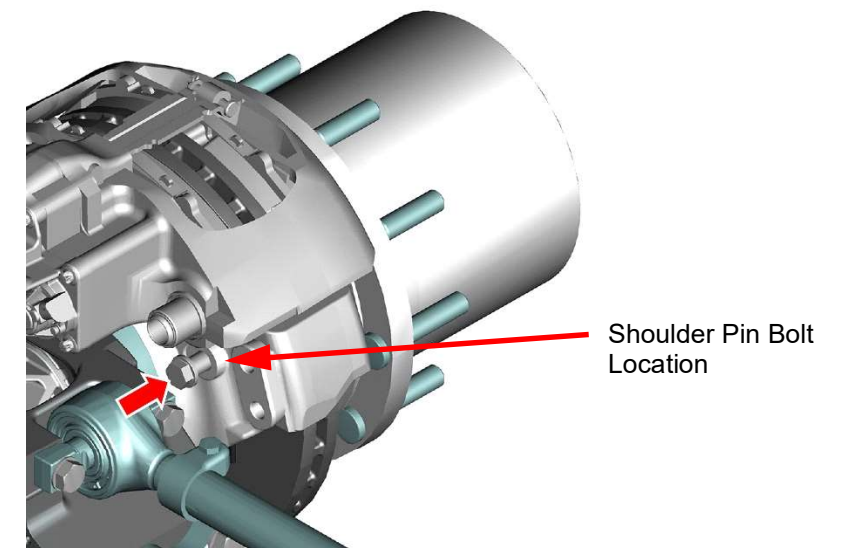
**Figure 11-57. Removing the Brake Caliper**

11. Position the replacement brake caliper on the rotor and the bracket.



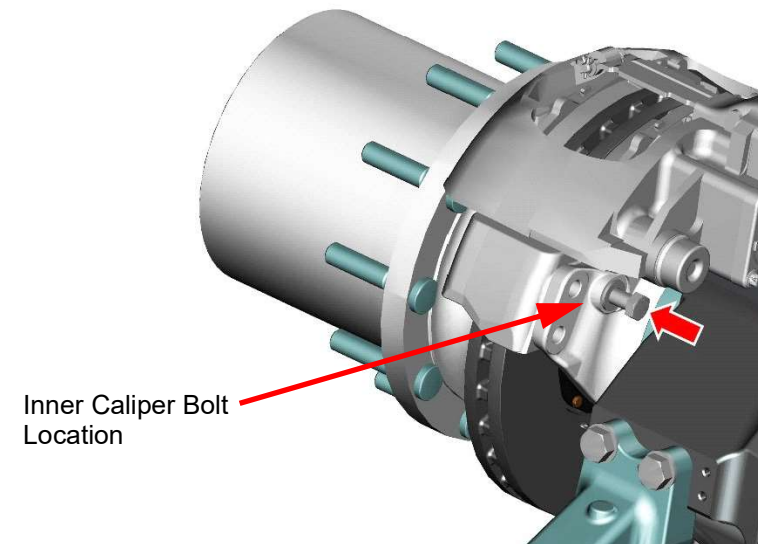
**Figure 11-58. Positioning the Replacement Brake Caliper**

12. Hand start the shoulder pin bolt. The shoulder pin bolt is the inside front bolt. M16x1.50x58/19-10.9 HHCS (no washer, qty. 1).



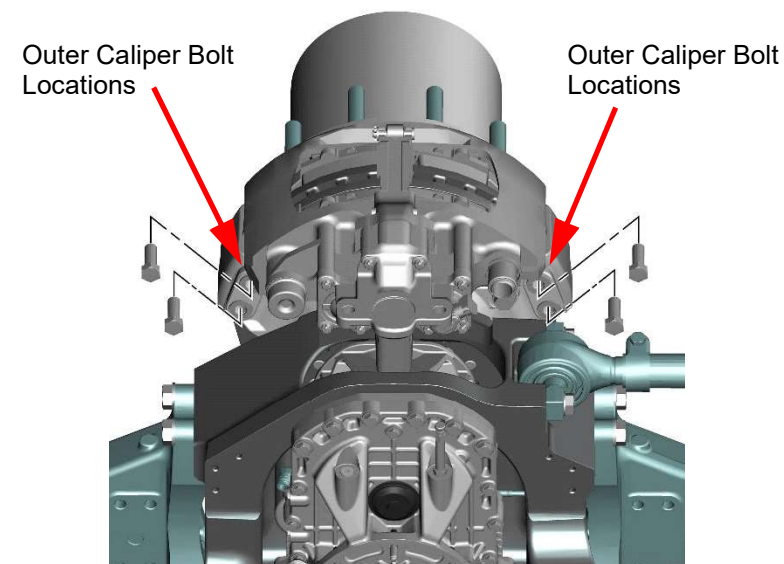
**Figure 11-59. Installing the Shoulder Pin Bolt**

13. Hand start the inner caliper bolt. M16x1.50x60/35-10.9 (qty. 1).



**Figure 11-60. Installing the Inner Caliper Bolt**

14. Hand start the outer bolts. M16x1.50x45/45-10.9 PHOS (qty. 4).

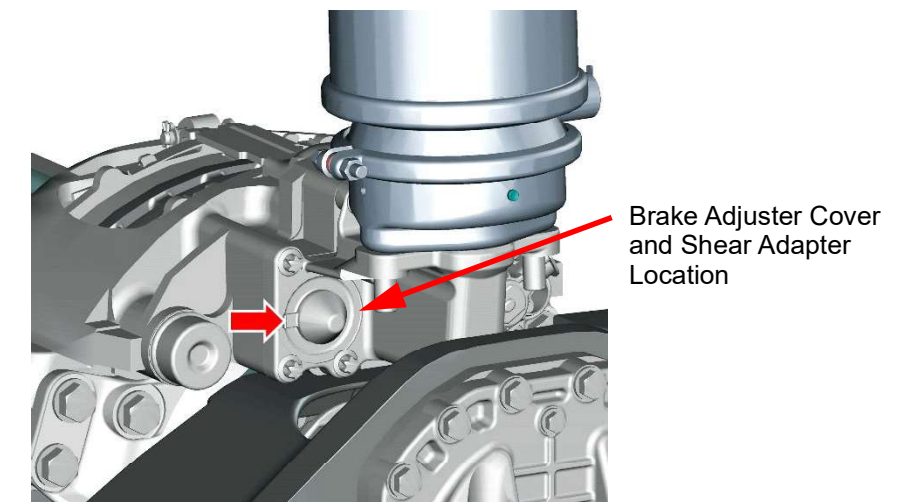


**Figure 11-61. Installing the Outer Caliper Bolts**

15. Using the dog bone tool TC-80411, snug the outer bolts and the inner bolt.
16. Using the dog bone tool TC-80411, **torque the shoulder pin bolt to 229 ft-lbs (310 Nm).**
17. Using the dog bone tool TC-80411, **torque the 4 outer bolts and the inner bolt to 229 ft-lbs (310 Nm).**
18. . Connect the brake lining sensor electrical connector.

19. Adjust the brakes until the brake pad comes in contact with the brake rotor, then back the adjuster back out three clicks.

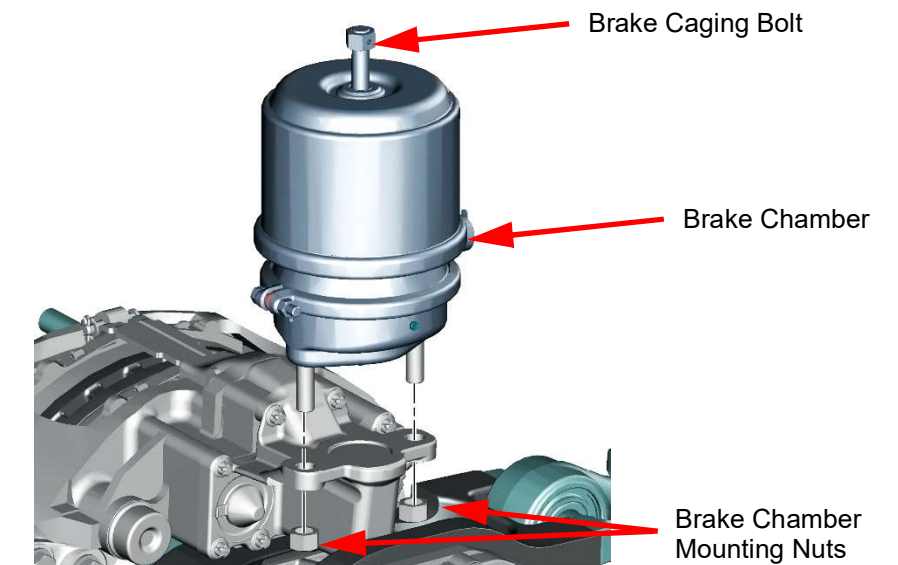
20. Install the brake adjuster cover.



**Figure 11-62. Installing the Brake Adjuster Cover**

21. Install the brake chamber, ensuring proper orientation of the air line connections

22. Using a 24mm socket, install the nuts. **Torque to 144 ft-lbs (195 Nm).**



**Figure 11-63. Installing the Brake Chamber**

23. Connect the air lines to the proper brake chamber port.

24. Release (un-cage) the parking brake chamber.

25. Install the wheels and tires onto the side of the axle being serviced.

26. Repeat the brake caliper replacement steps for the opposite side of the axle, if required.
27. Lower the vehicle off the jack stands and chock the wheels
28. Set the parking brake and remove the wheel chocks.
29. Test for proper brake operation and return the vehicle to service.

## DuoPower Axle Cradle Service Procedures

The DuoPower Axle cradle mounted components may require occasional service or replacement. The following procedures for servicing the DuoPower cradle mounted components are covered:

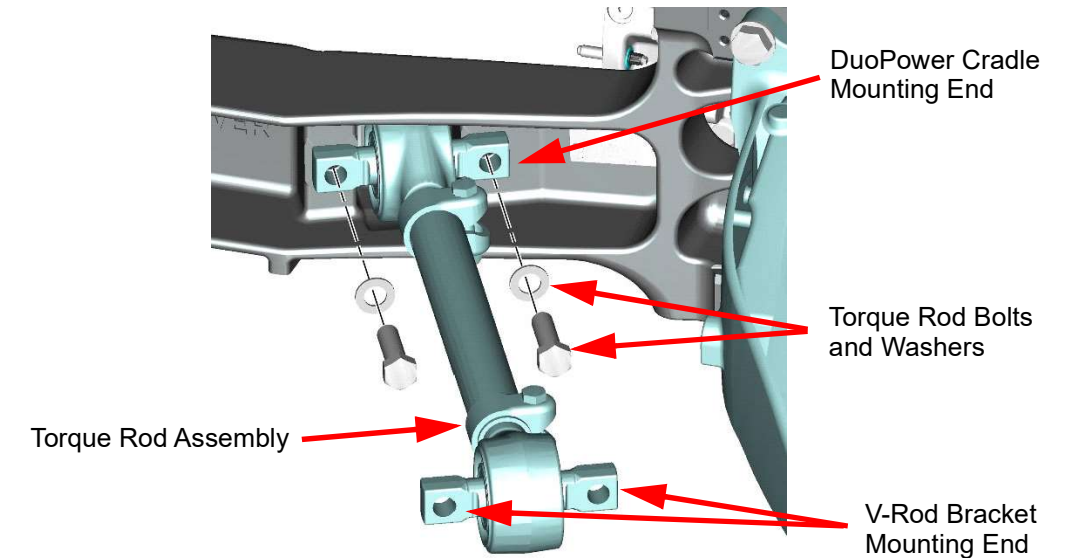
- Torque Rod (Quad Link) Removal and Replacement
- Suspension Arm Removal and Replacement
- Wheel End Hub Seal Removal and Replacement
- Axle Shaft Removal and Replacement
- Spindle Removal and Replacement

## Torque Rod (Quad Link) Removal and Replacement

To remove and replace a Torque Rod (Quad Link), perform the following:

**IMPORTANT!** Always replace the bolts when performing this procedure.

1. Remove the bolts, washers, and the torque rod assembly. Discard the bolts.



**Figure 11-64. Removing the Torque Rod**

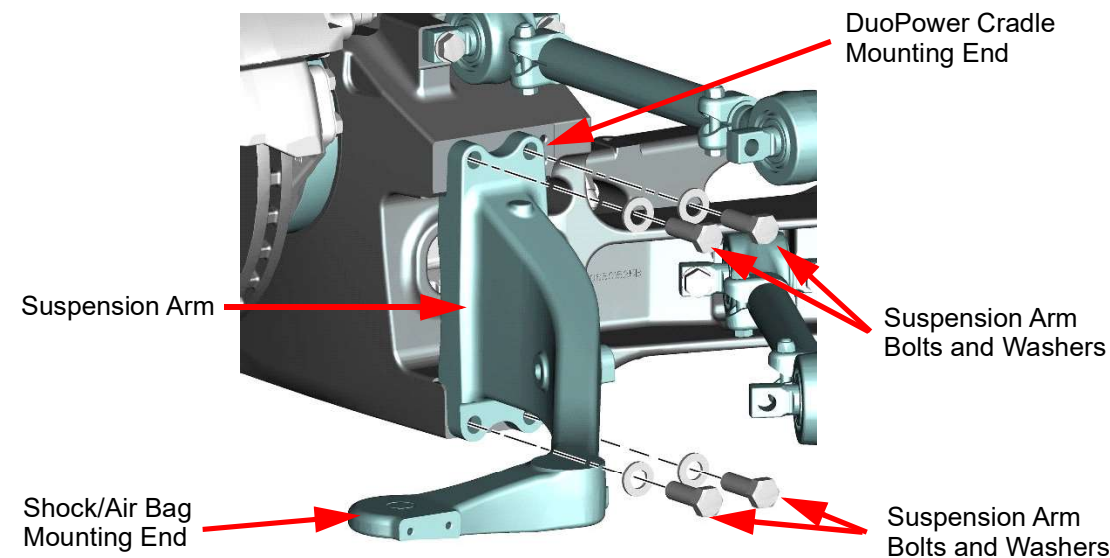
2. Obtain new torque rod bolts (and washers, if needed).
  - Bolts: M18x1.50x60/42-10.9 HHCS (qty. 2)
  - Washers: M18 (qty. 2)
3. Apply Loctite 243 to the bolt threads.
4. Using a 27mm socket, install the Torque Rod Assembly, washers, and bolts. **Torque bolts to 339 ft-lbs (460 Nm).**
5. Verify the DuoPower Axle alignment.

## Suspension Arm Removal and Replacement

To remove and replace a Suspension Arm, perform the following:

**IMPORTANT!** Always replace the bolts when performing this procedure.

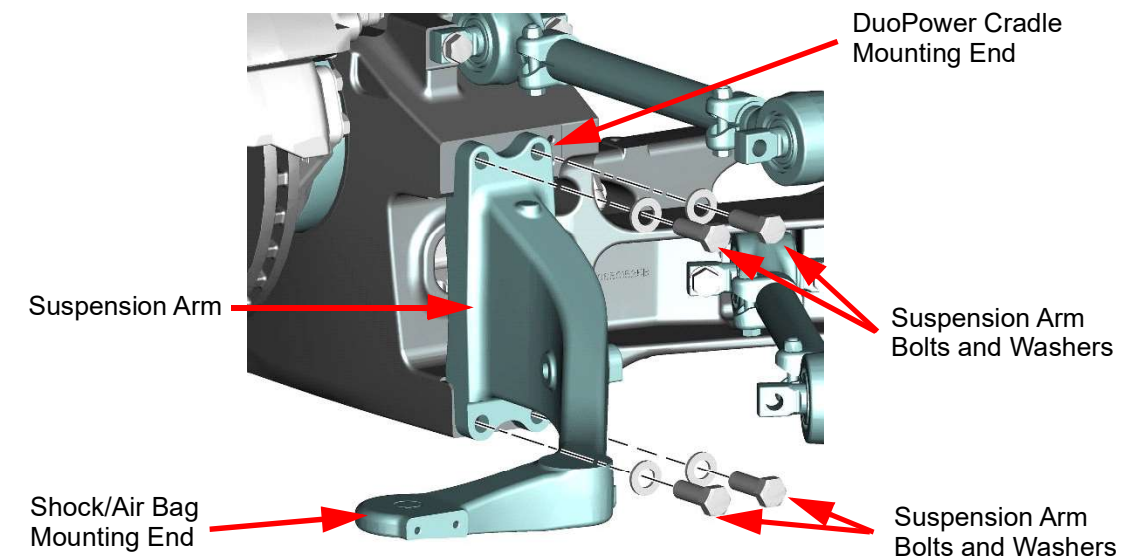
1. Drain air from all air bags on the suspension arms.
2. Raise and properly support the vehicle using jack stands.
3. Using a properly rated lifting device, raise and support the DuoPower Axle, taking the weight off the suspension arms.
4. Remove the bottom shock mounting hardware on the suspension arm being replaced.
5. Remove the bottom air bag mounting hardware for the suspension arm being replaced.
6. Remove the bolts, washers, and the suspension arm. Discard the bolts.



**Figure 11-65. Removing the Suspension Arm**

7. Obtain new suspension arm bolts (and washers, if needed).
  - Bolts: M20x2.50x60/46-10.9 HHCS (qty. 4)
  - Washers: M20 (qty. 4)
8. Apply Loctite 243 to the bolt threads.

9. Using a 30mm socket, install the Suspension Arm, washers and bolts. Torque bolts to 424 ft-lbs (575 Nm).



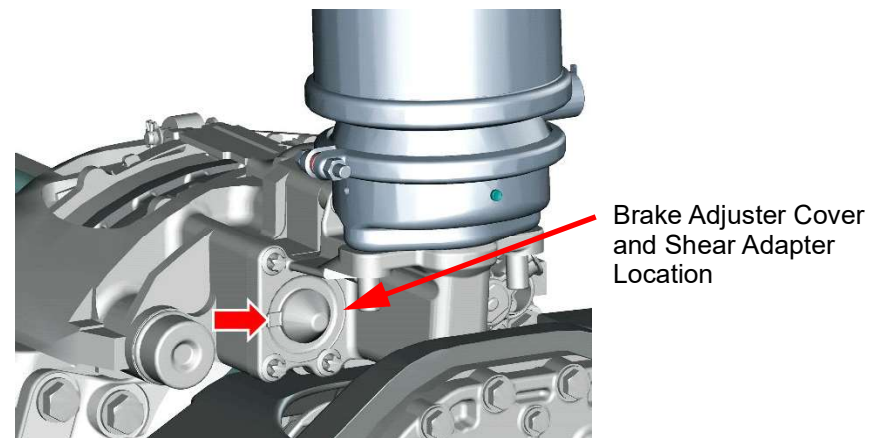
**Figure 11-66. Installing the Suspension Arm**

10. Install the air bag and bottom mounting hardware on the replacement suspension arm.
11. Install the shock and bottom mounting hardware on the replacement suspension arm.
12. Slowly lower the DuoPower Axle lifting device, removing support for the DuoPower Axle and placing the weight back on the suspension arms.
13. Raise the vehicle, remove jack stands supporting the vehicle, then lower the vehicle.
14. Return air supply to all air bags on the suspension arms.
15. Verify proper vehicle operation.

## Wheel End Hub Seal Removal and Replacement

To remove and replace a Wheel End Hub Seal, perform the following:

1. Chock the wheels and release the parking brake.
2. Raise and properly support the vehicle using jack stands.
3. Remove the wheels and tires from the side of the axle being serviced.
4. Remove the brake adjuster cover and place aside.



**Figure 11-67. Removing the Brake Adjuster Cover**

5. Using the shear adapter, back off the brakes.

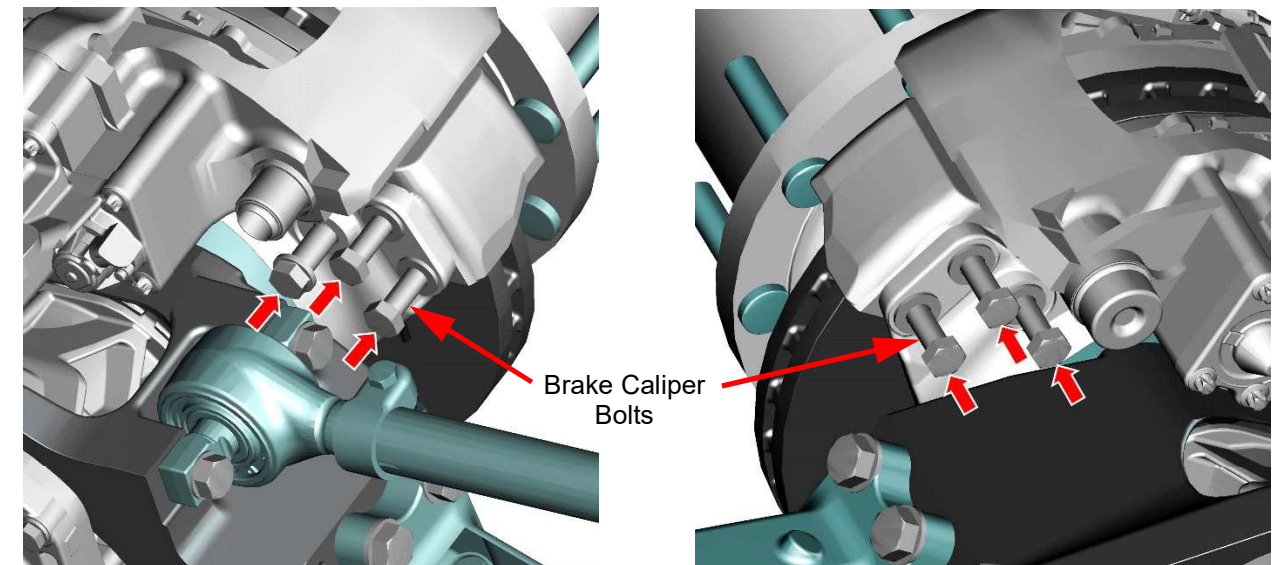
**NOTICE!** If two shear adapters fail while attempting to back off the brakes, install a new brake caliper as internal damage may be present in the brake caliper.

6. Disconnect the brake lining wear sensor electrical connector.

7. Using the dog bone tool TC-80411, loosen the brake caliper bolts.
 

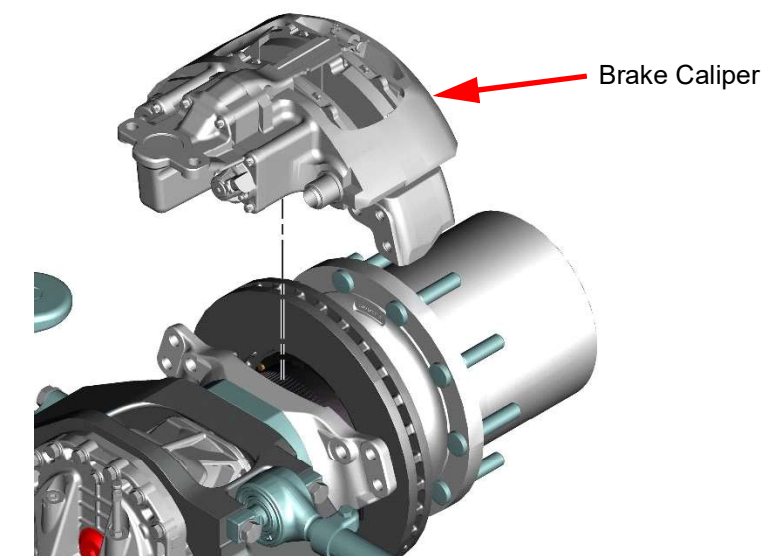
**Note:** Leave the bolts in the bracket after removing the brake caliper.

  - a. Shoulder pin bolt: M16x1.50x58/19-10.9 HHCS (no washer, qty. 1)
  - b. Inner bolt: M16x1.50x60/35-10.9 (qty. 1)
  - c. Outer bolts: M16x1.50x45/45-10.9 PHOS (qty. 4)



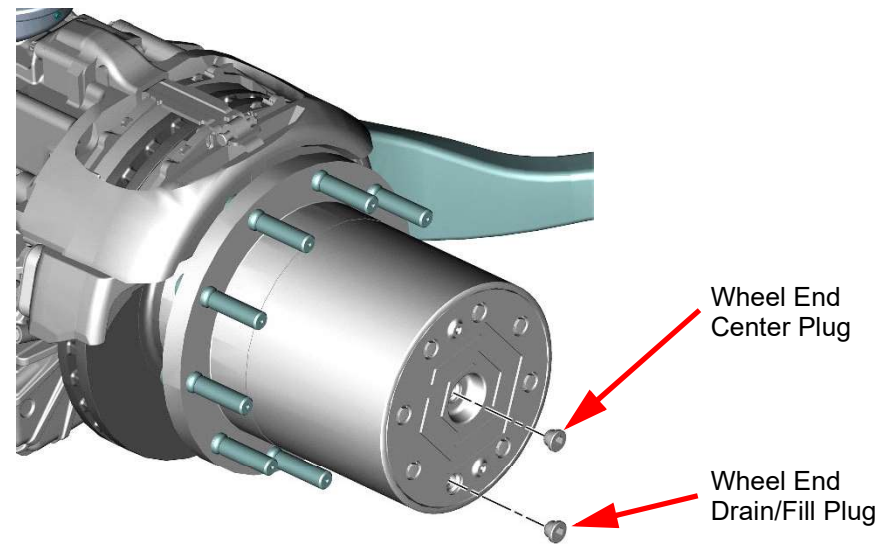
**Figure 11-68. Removing the Brake Caliper Bolts**

8. Remove the brake caliper.



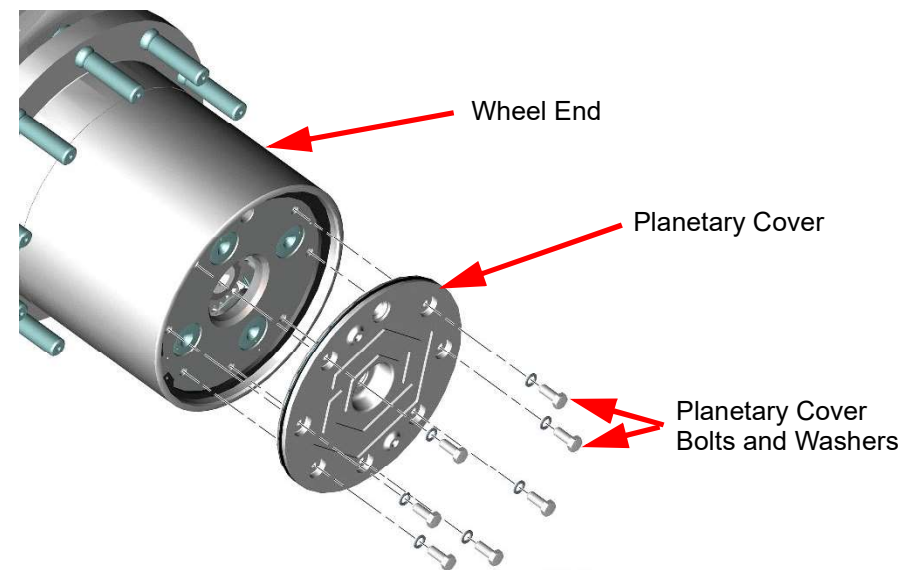
**Figure 11-69. Removing the Brake Caliper**

9. Rotate the wheel end until the outer drain/fill plug is at the 6 o'clock (vertically down) position.
10. Place a suitable catch pan capable of holding 3 quarts of fluid below the hub.
11. Using a 12mm Allen socket, remove the drain/fill plug and center plug to allow the wheel end to drain into the catch pan.



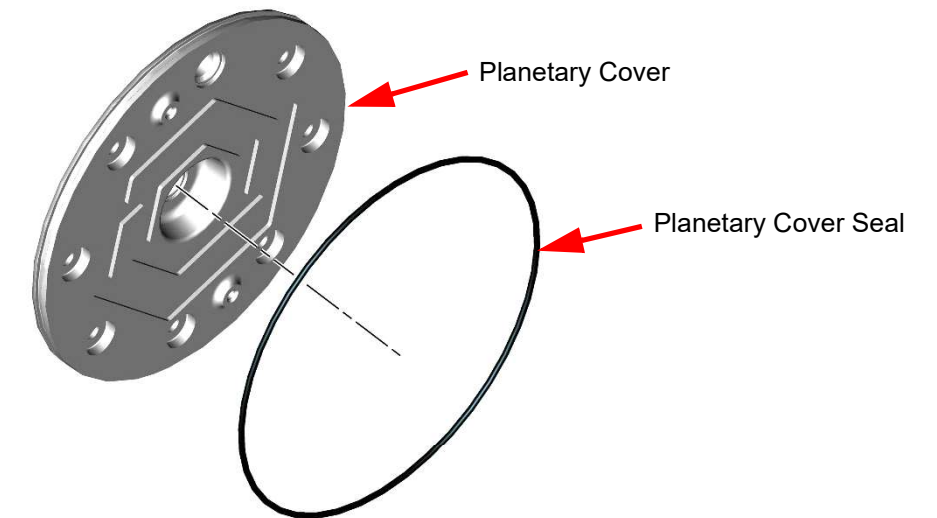
**Figure 11-70. Removing Wheel End Drain/Fill Plug and Center Plug**

12. Using a 16mm socket, remove the bolts, washer seals and planetary cover. Discard the washer seals.



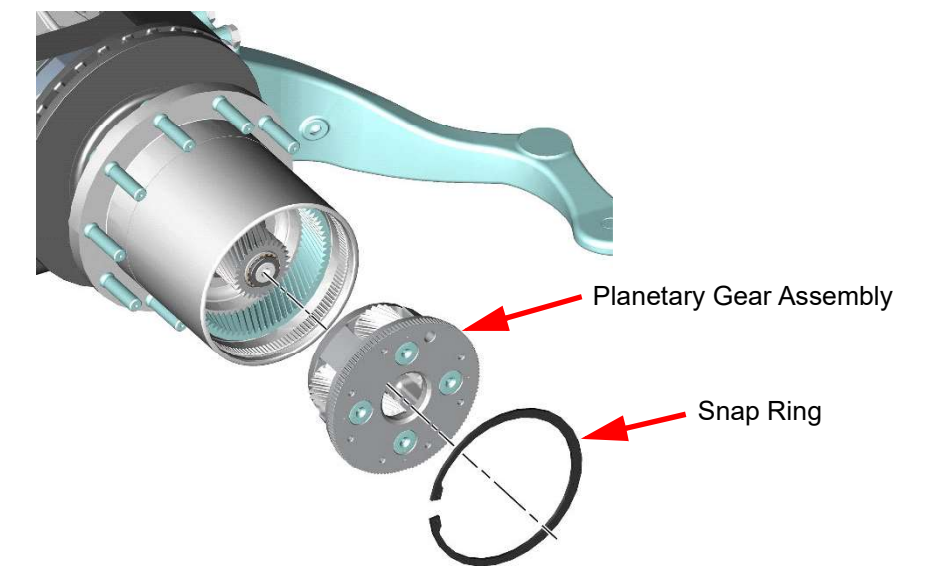
**Figure 11-71. Removing the Planetary Cover**

13. Remove and discard the planetary cover O-ring seal.



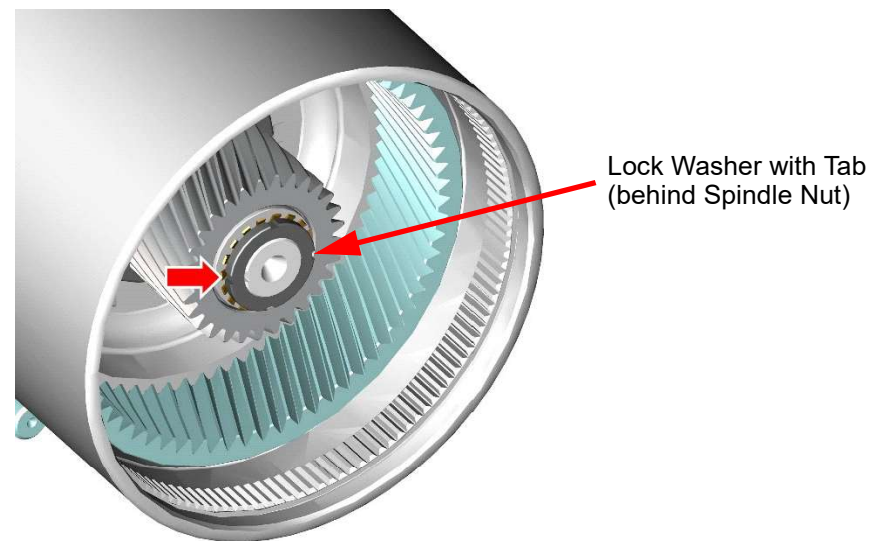
**Figure 11-72. Removing Planetary Cover Seal**

14. Using snap ring pliers, remove the snap ring and the planetary gear assembly.



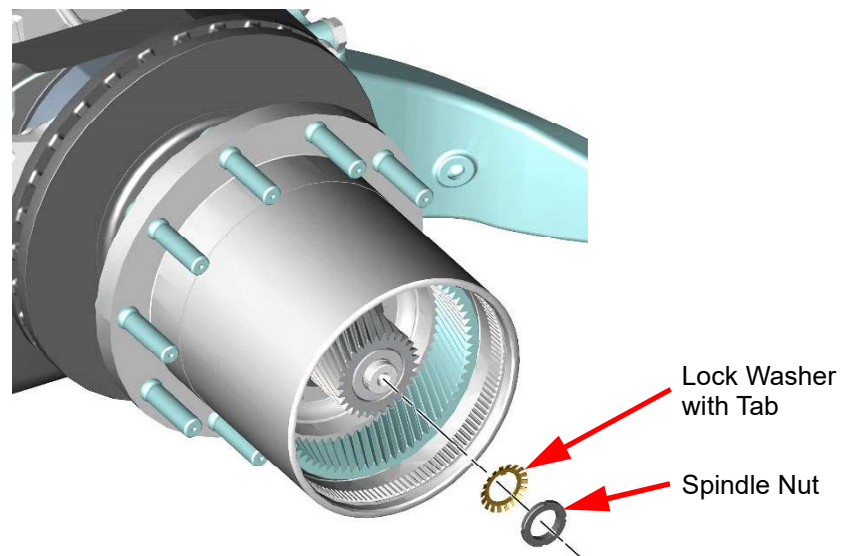
**Figure 11-73. Removing Planetary Gear Assembly**

15. Using a flat-head screwdriver (or similar tool), straighten out the tab on the spindle nut lock washer.



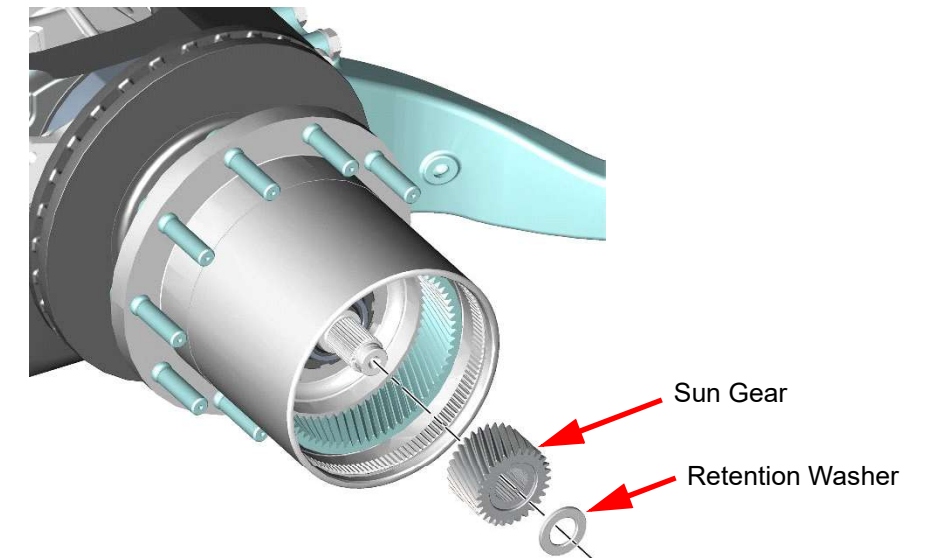
**Figure 11-74. Straightening Tab on Spindle Nut Lock Washer**

16. Using a TMFS #7 spindle nut socket, remove the M35 axle shaft nut and the lock washer. Discard the lock washer.  
**Note:** This nut was torqued to 45 ft-lb during factory assembly and may require a light impact or small breaker bar to loosen the nut.



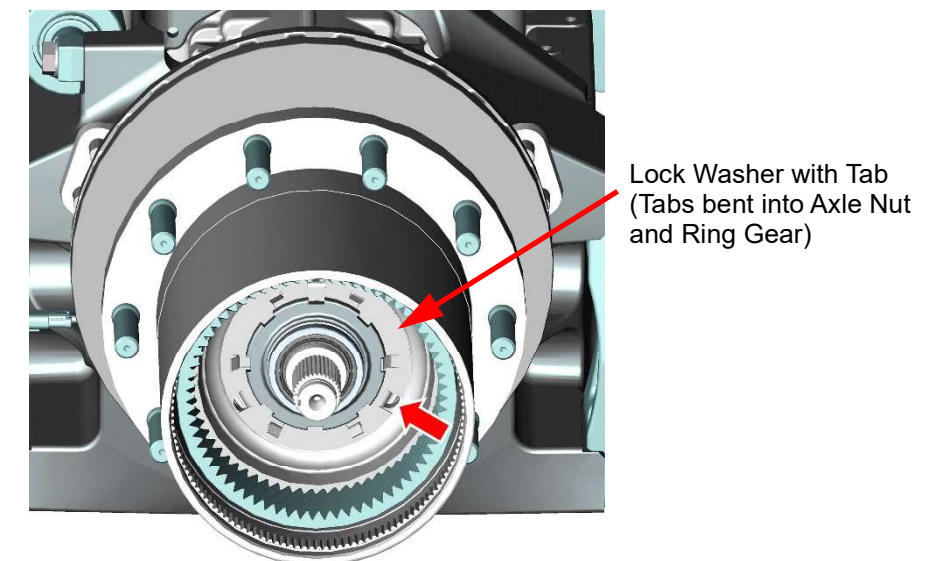
**Figure 11-75. Removing Spindle Nut and Lock Washer**

17. Remove the retention washer and the sun gear from the axle shaft.



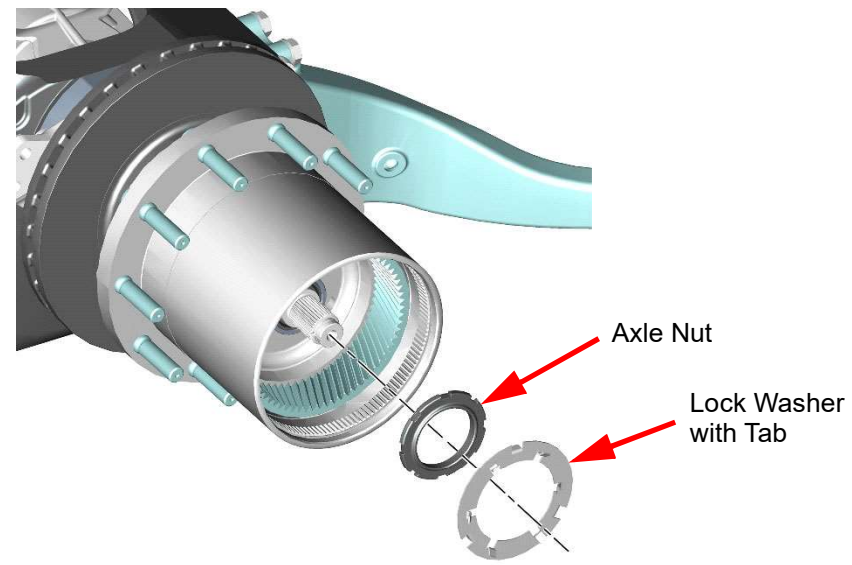
**Figure 11-76. Removing Retention Washer and Sun Gear**

18. Straighten out the tab on the axle nut lock washer.



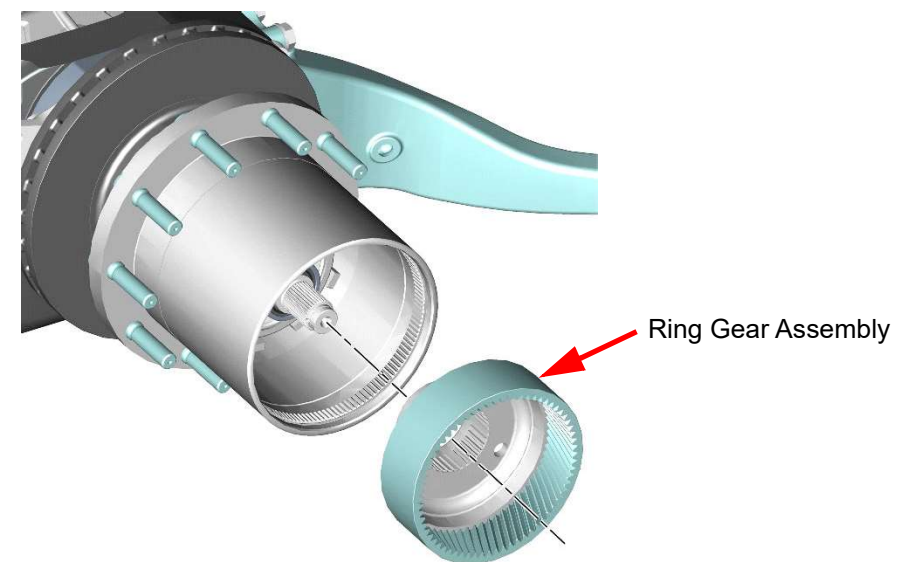
**Figure 11-77. Straightening Tab on Axle Nut Lock Washer**

19. Remove the axle nut and the lock washer. Discard the lock washer.



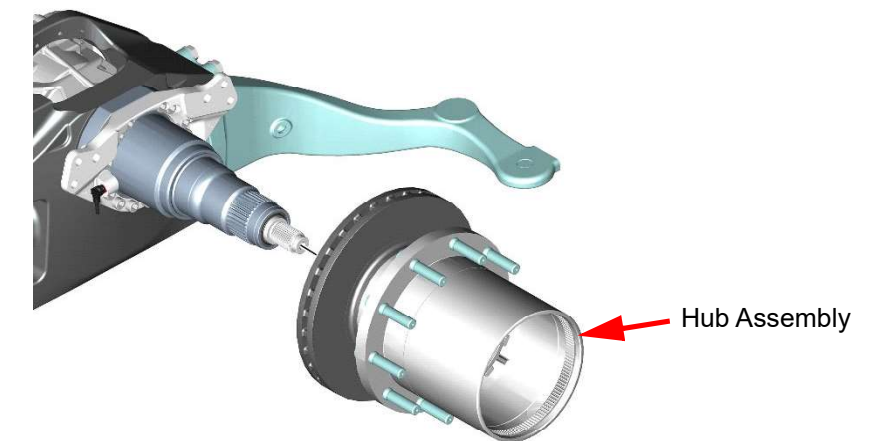
**Figure 11-78. Removing Axle Nut and Lock Washer**

20. Remove the ring gear assembly and inspect the axle bearing.



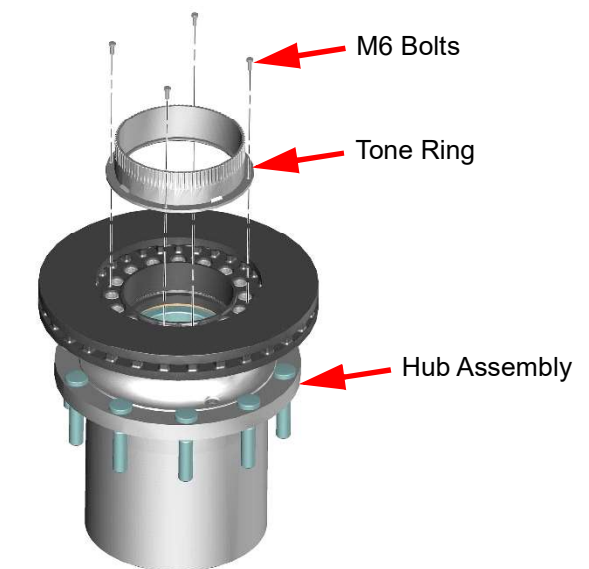
**Figure 11-79. Removing Ring Gear Assembly**

21. Using a properly rated lifting device, remove the hub assembly and place on a work bench.



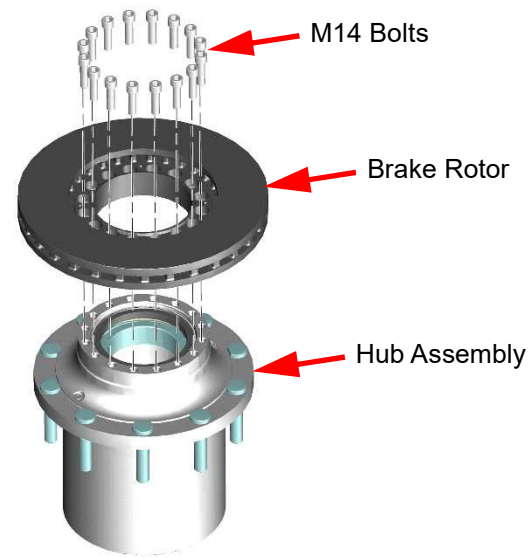
**Figure 11-80. Removing Hub Assembly**

22. Using a 10mm socket, remove the bolts securing the ABS (anti-lock brake sensor) tone ring and remove the tone ring from the hub assembly.



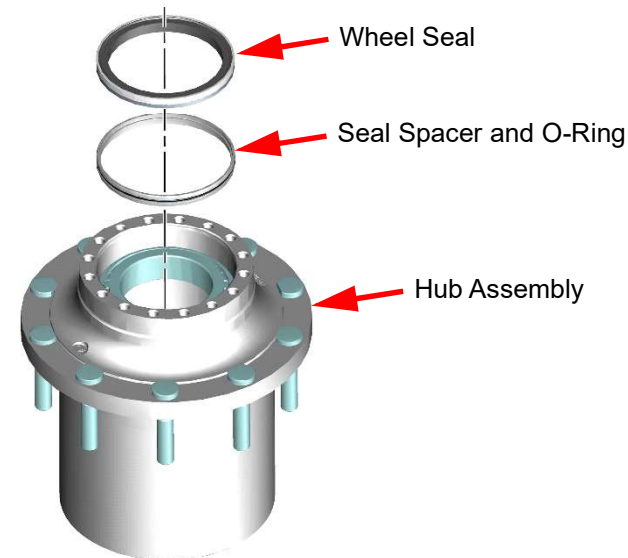
**Figure 11-81. Removing Tone Ring from Hub Assembly**

23. Using a 12mm Allen socket, remove the bolts securing the Brake Rotor and remove the brake rotor from the hub assembly.



**Figure 11-82. Removing Brake Rotor from Hub Assembly**

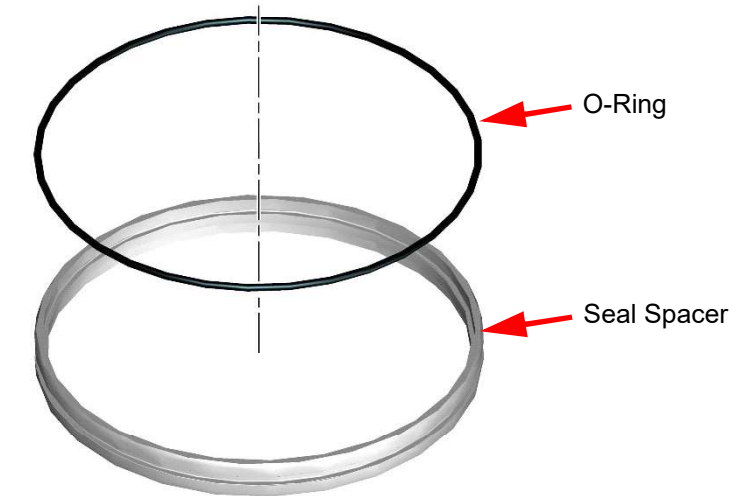
24. Remove and discard the wheel seal, seal spacer, and O-ring. Then remove and inspect the axle bearing.



**Figure 11-83. Removing Wheel Seal, Seal Spacer, and O-Ring from Hub Assembly**

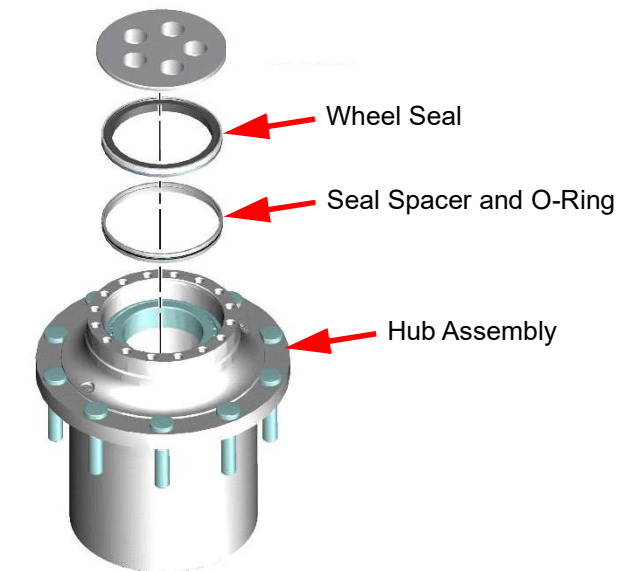
**NOTICE!** This completes the Wheel End Hub Seal Removal portion of the procedure. The following steps detail re-assembly and installation of the Wheel End.

25. Install the new O-ring seal onto the new seal spacer.



**Figure 11-84. Installing O-Ring onto Seal Spacer**

26. Apply US Lube or other approved SAE 80W90 oil to the axle bearing seal bore and bearing cone and then install the axle bearing into the hub.

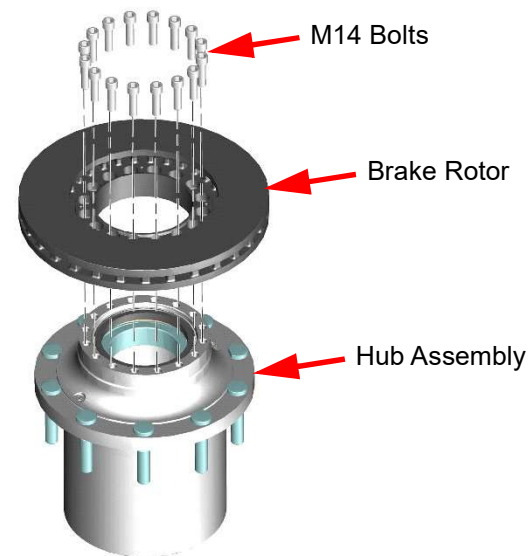


**Figure 11-85. Installing Axle Bearing, Wheel Seal, Seal Spacer (with O-Ring) into Hub Assembly**

27. Position the seal spacer (with O-ring) into the hub, and using an appropriate size seal driver press the seal spacer into the hub.
28. Position the wheel seal into the hub, and using an appropriate size seal driver press the wheel seal into the hub.

29. Using a 12mm Allen socket, install the brake rotor and bolts onto the hub assembly. **Torque the bolts to 155 ft-lbs (210 Nm).**

- Bolts: M14x1.50x50/40-10.9 SHCS Patch (qty. 16)

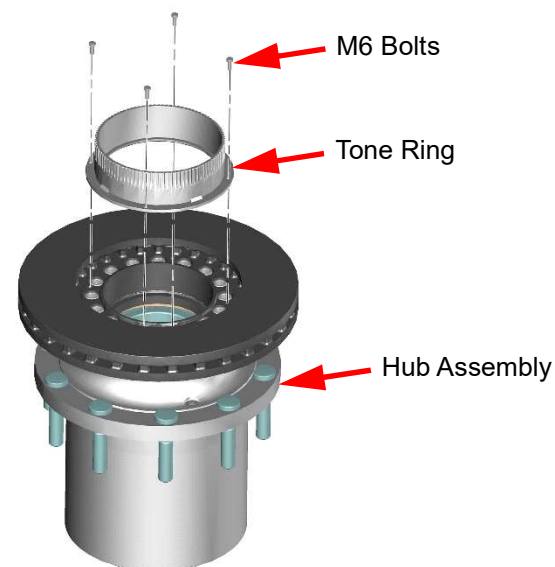


**Figure 11-86. Installing Brake Rotor onto Hub Assembly**

30. Apply Loctite 243 to the threads of the M6 bolts used to secure the Tone Ring.

31. Using a 10mm socket, install the ABS (anti-lock brake sensor) tone ring and bolts into the hub assembly. **Torque the bolts to 11 ft-lbs. (15 Nm).**

- Bolts: M6x1.00x16/16-10.9 HHCS (qty. 4)

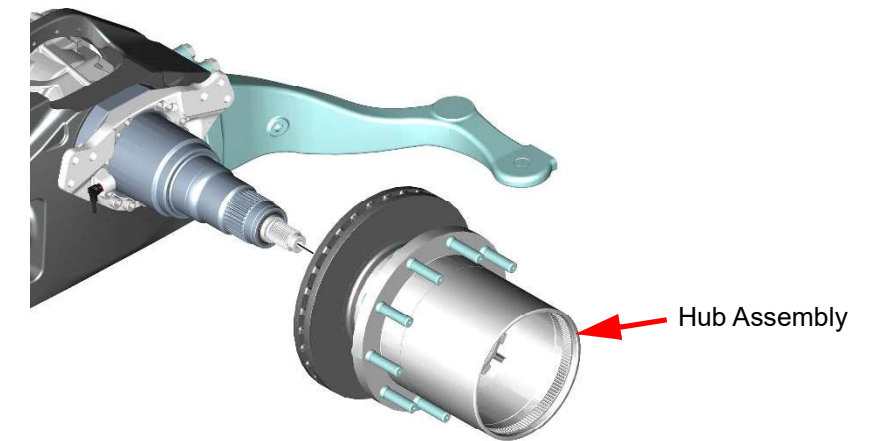


**Figure 11-87. Installing Tone Ring onto Hub Assembly**

32. Using a properly rated lifting device, carefully position the hub assembly on the spindle.

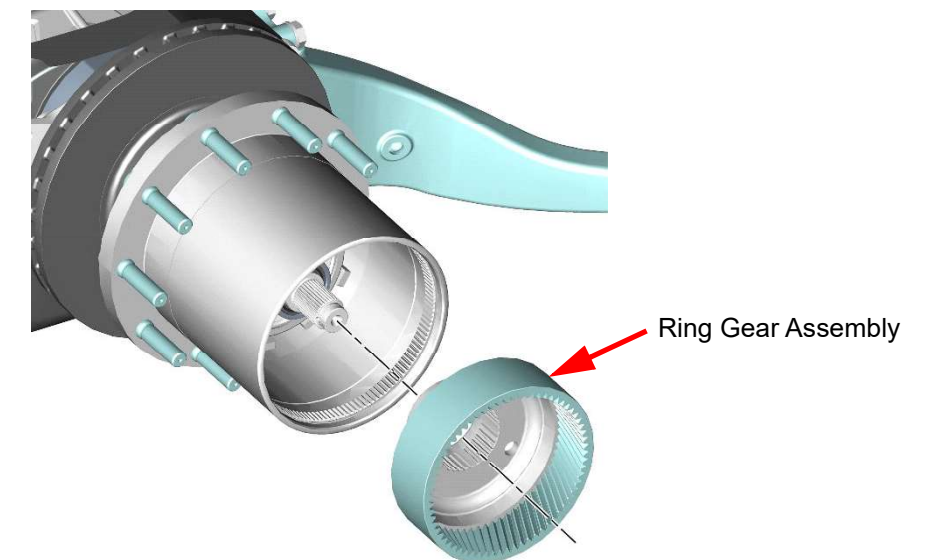


Use extreme care to ensure that the wheel seal does not hit the spindle while positioning and installing the hub assembly. Damage to the wheel seal can occur if allowed to hit the spindle.



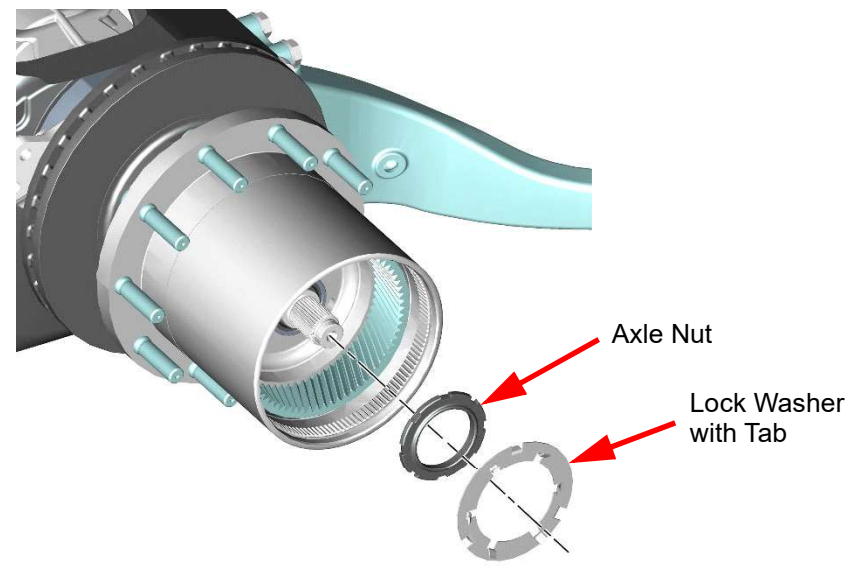
**Figure 11-88. Installing Hub Assembly**

33. Apply US Lube or other approved SAE 80W90 oil to the axle bearing and then install the ring gear assembly into the hub assembly.



**Figure 11-89. Installing Ring Gear Assembly**

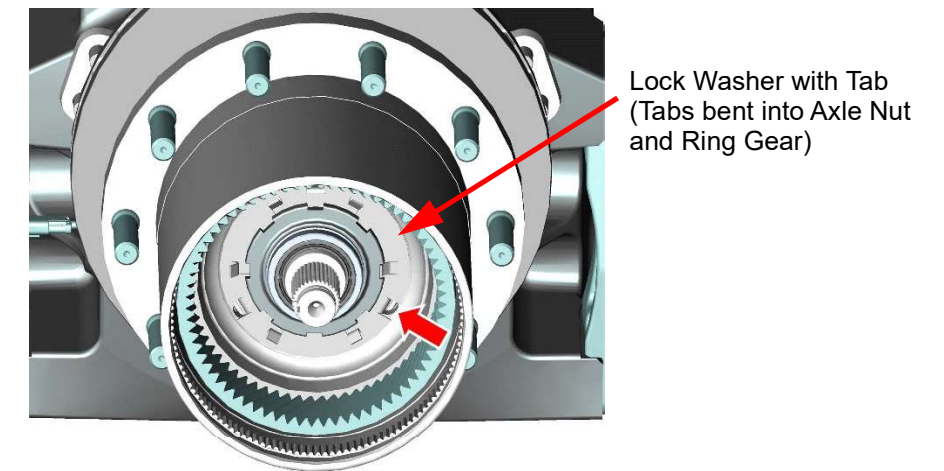
34. Install the new lock washer into the ring gear with three tabs bent down into the holes on the ring gear.



**Figure 11-90. Installing Axle Nut and Lock Washer**

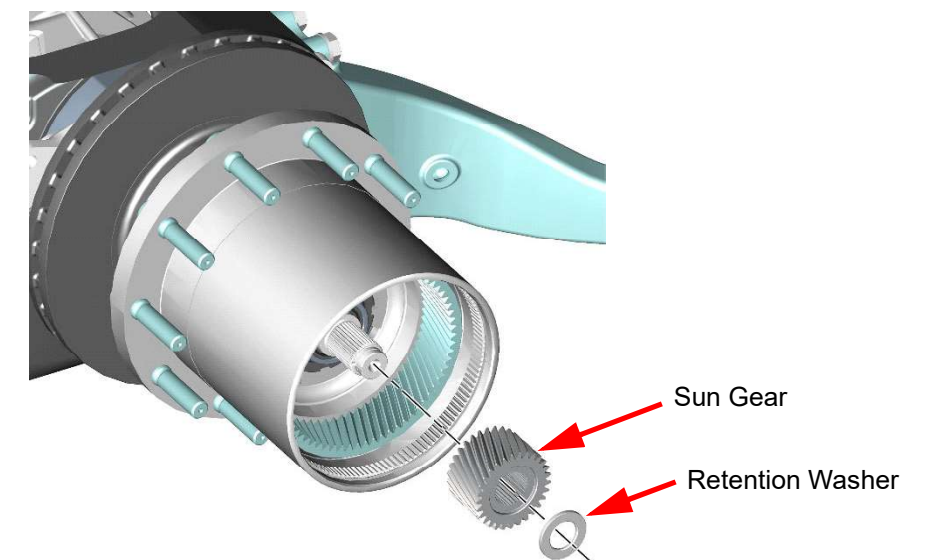
35. Apply a small amount of “never seize” on the threads of the axle nut and hand start on the spindle. **Torque the axle nut to 450 ft-lbs (610 Nm)** using a TMFS5 torque adapter tool (Proterra PN 120-7746), ensuring both torque wrench detents are aligned with detent holes on the TMFS5 torque adapter tool.  
**IMPORTANT!** Failure to align detents could result in permanent coupling of torque wrench and torque adapter tool.
36. Spin the hub assembly in both directions. Strike the hub with an 8 pound weight to seat the bearing. **Torque the axle nut a second time to 450 ft-lbs (610 Nm).**
37. Spin the hub assembly in both directions. Back off the axle nut. **Torque the axle nut to 290 ft-lbs (393 Nm).**  
**Note: Torque as needed to align tabs, not exceeding 345 ft-lbs (468 Nm).**

38. Using a tab bending tool, bend over two tabs into axle nut slots.



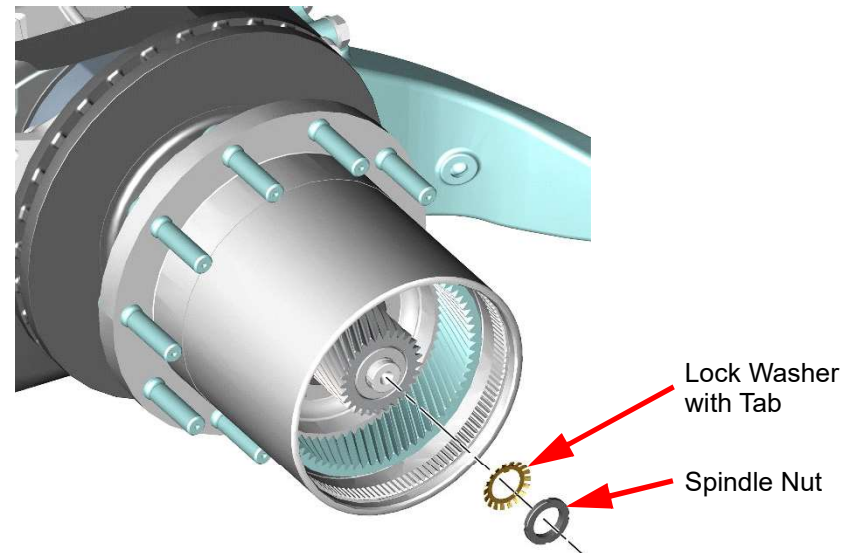
**Figure 11-91. Bending Tabs on Axle Nut Lock Washer**

39. Install the sun gear and retention washer on the axle shaft.

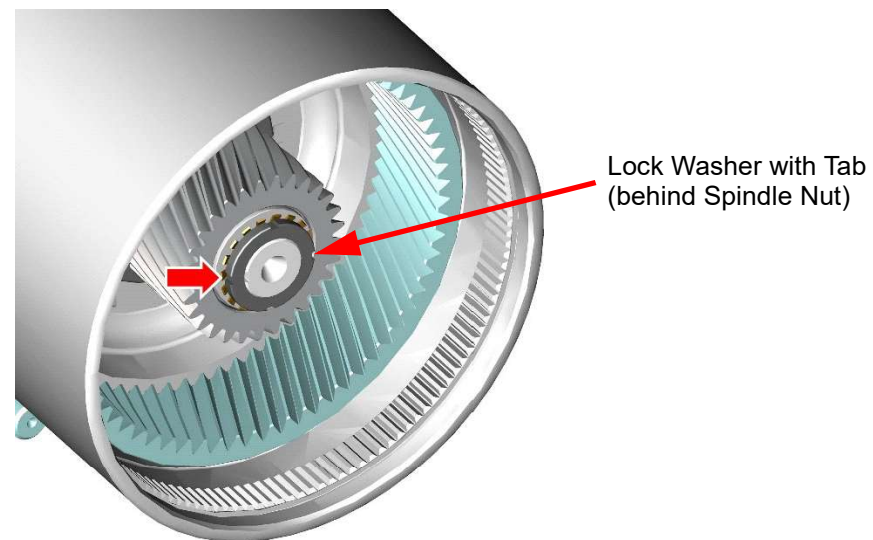


**Figure 11-92. Installing Sun Gear and Retention Washer**

40. Hand tighten the spindle nut socket (Proterra PN 120-7747), install a new lock washer and the spindle nut on the axle shaft.  
**IMPORTANT!** The spindle nut should be installed with the chamfer side inboard.  
**Note:** It may be necessary to advance the nut to line up the tab on the lock washer.

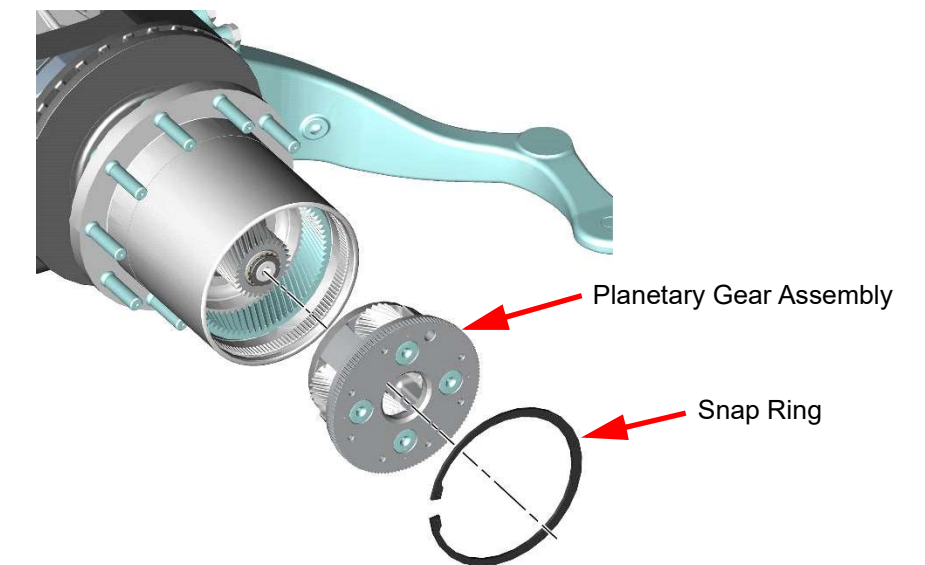


**Figure 11-93. Hand Tightening the Spindle Nut Using a tab bending tool, bend over a lock washer tab.**



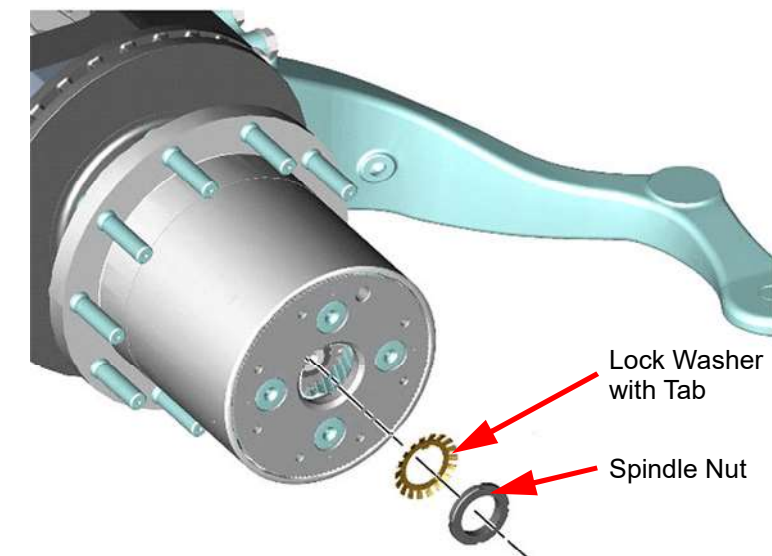
**Figure 11-94. Bending a Tab on the Spindle Nut Lock Washer**

41. Using snap ring pliers, Install the planetary gear assembly and snap ring.  
**Note:** A soft headed hammer or rubber mallet may be needed to seat the planetary.



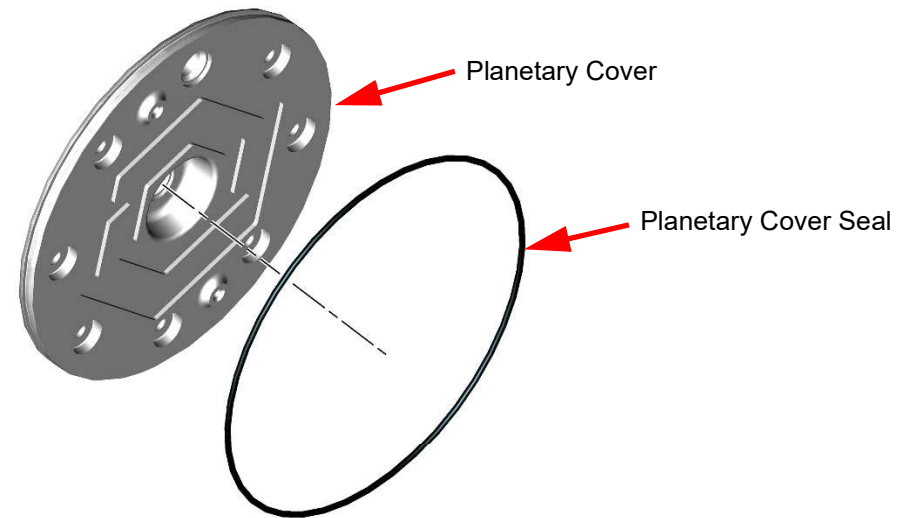
**Figure 11-95. Installing Planetary Gear Assembly**

42. Using a TMFS 7 spindle nut socket (Proterra PN 120-7747), Torque the nut to 45 ft-lbs (61 Nm).



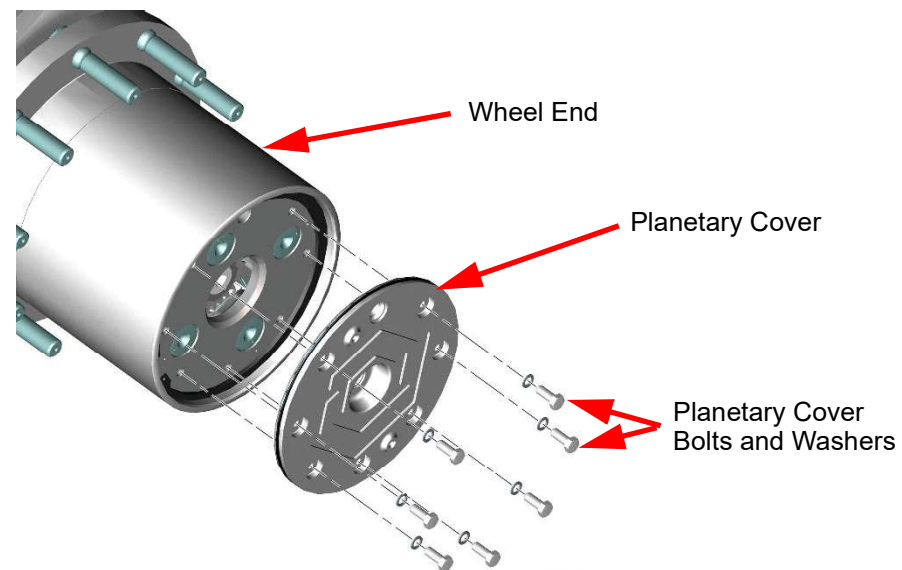
**Figure 11-96. Installing Spindle Nut and Lock Washer**

43. Install a new O-ring seal on the planetary cover and lubricate seal with US Lube or other approved SAE 80W90 oil.



**Figure 11-97. Installing Planetary Cover Seal**

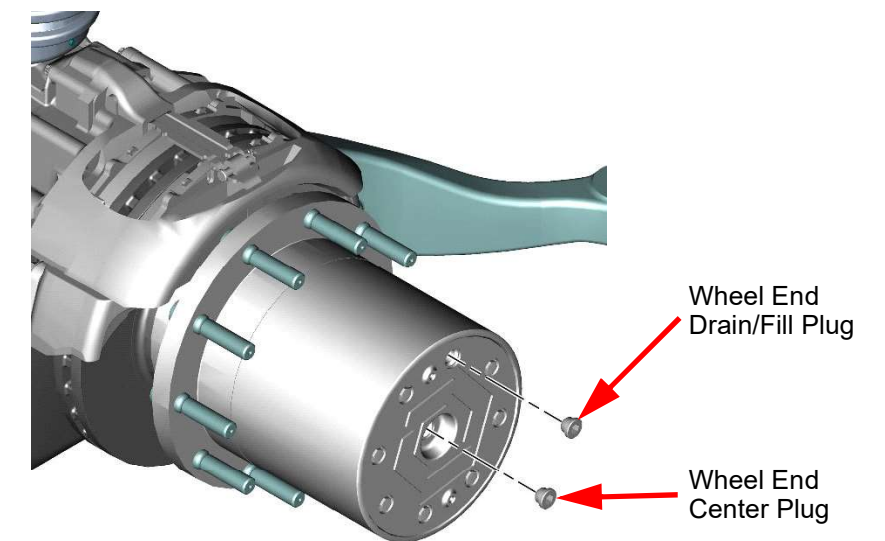
44. Apply Loctite 243 to the threads of the planetary cover bolts.
45. Verify the location of the fill hole on the planetary cover in relation to the planetary gear and align.
46. Using a 16mm socket, install new washer seals and the cover bolts securing the planetary cover. **Torque the bolts to 50 ft-lbs (68 Nm).**



**Figure 11-98. Installing the Planetary Cover**

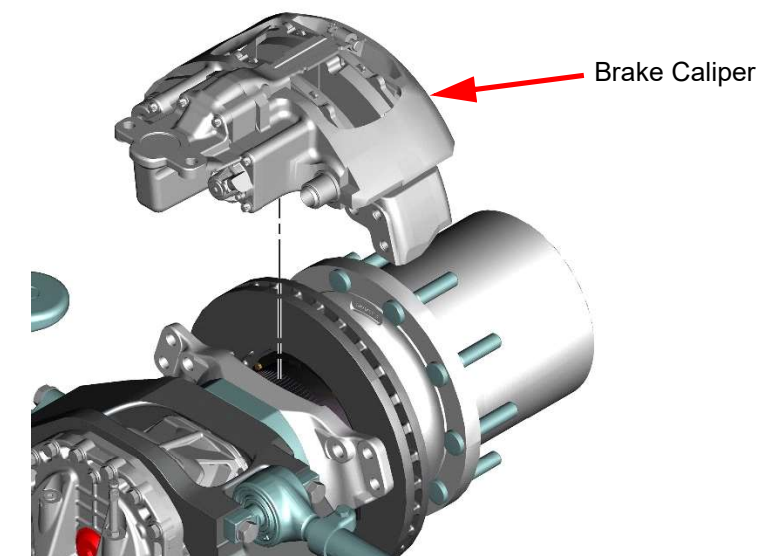
47. Check and clean the drain/fill plug and center plug, then lube the O-rings on the plugs with the approved SAE 80W90 oil prior to reinstalling.

48. Rotate the wheel end until the outer drain/fill plug is at the 2 o'clock (vertically up and slightly to the side) position.



**Figure 11-99. Installing Wheel End Drain/Fill Plug and Center Plug**

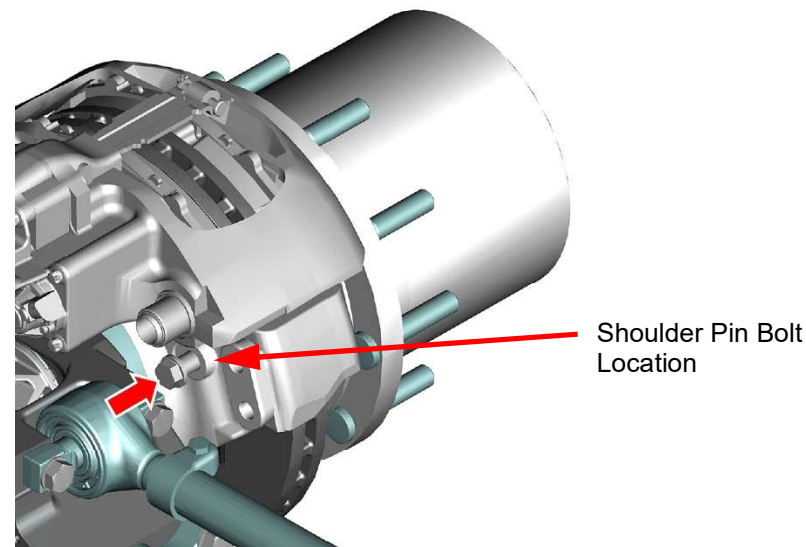
49. Fill the wheel end with approved SAE 80W90 oil until the oil flows out of the center hole.
50. Using a 12mm Allen socket, install the center plug and drain/fill plug. **Torque to 22 ft-lbs (30 Nm).**
51. Position the brake caliper on the rotor and the bracket.



**Figure 11-100. Positioning the Brake Caliper**

52. Hand start the shoulder pin bolt. The shoulder pin bolt is the inside front bolt.

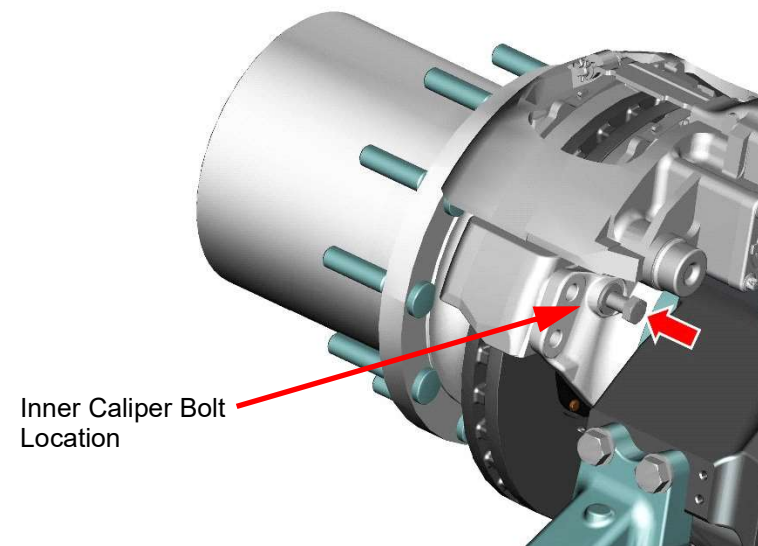
- Bolt: M16x1.50x58/19-10.9 HHCS (no washer, qty. 1).



**Figure 11-101. Installing the Shoulder Pin Bolt**

53. Hand start the inner caliper bolt.

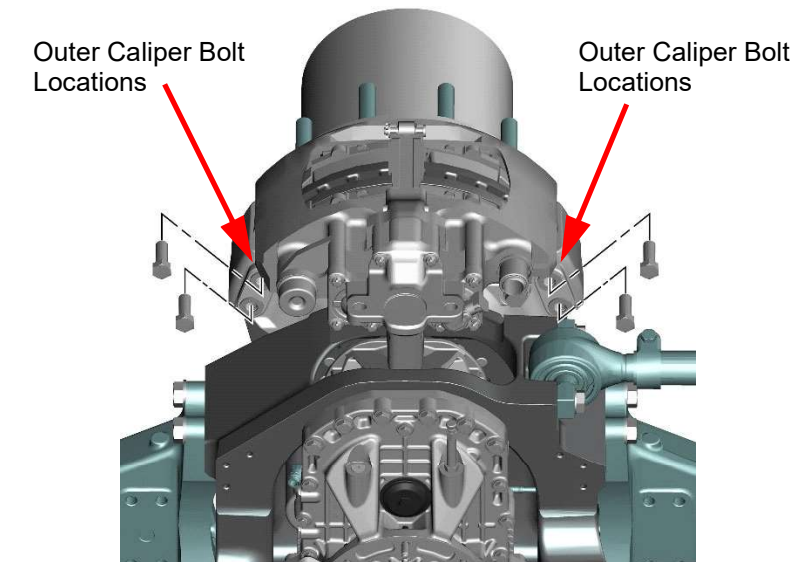
- Bolt: M16x1.50x60/35-10.9 (qty. 1).



**Figure 11-102. Installing the Inner Caliper Bolt**

54. Hand start the outer bolts.

- Bolts: M16x1.50x45/45-10.9 PHOS (qty. 4).



**Figure 11-103. Installing the Outer Caliper Bolts**

55. Using the dog bone tool, snug the outer bolts and the inner bolt.

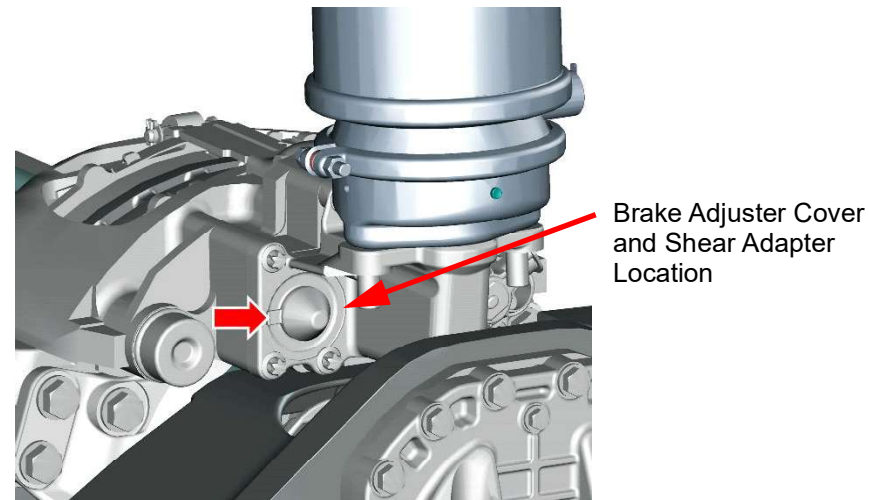
56. Using the dog bone tool, **torque the shoulder pin bolt to 229 ft-lbs (310 Nm).**

57. Using the dog bone tool, **torque the 4 outer bolts and the inner bolt to 229 ft-lbs (310 Nm).**

58. Connect the brake lining sensor electrical connector.

59. Adjust the brakes until the brake pad comes in contact with the brake rotor, then back the adjuster back out three clicks.

60. Install the brake adjuster cover.



**Figure 11-104. Installing the Brake Adjuster Cover**

61. Install the wheels and tires.

62. Lower the vehicle off the jack stands and chock the wheels.

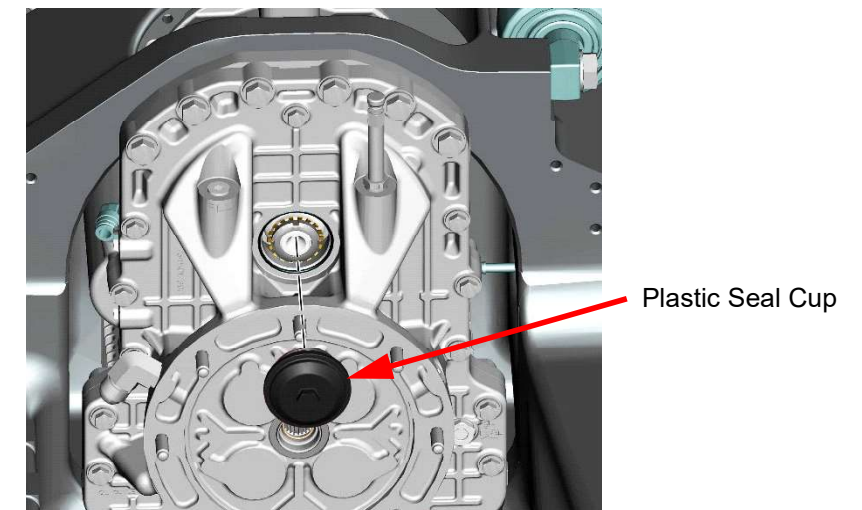
63. Set the parking brake.

64. Verify proper vehicle operation and complete service documentation, as required.

## Axle Shaft Removal and Replacement

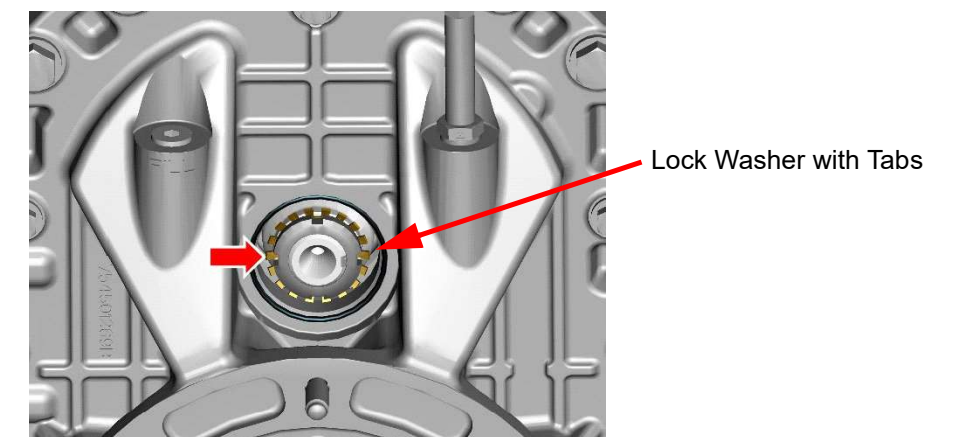
To remove and replace an Axle Shaft, perform the following:

1. Chock the wheels and release the parking brake.
2. Raise and properly support the vehicle using jack stands.
3. Referencing the DuoPower Axle Removal and Replacement procedure, remove the DuoPower Axle from the vehicle.
4. Referencing the Traction Motor Removal and Replacement procedure, remove the Traction Motor from the DuoPower Axle.
5. Remove the wheels and tires from the side of the axle being serviced.
6. Using a 16mm socket, remove and discard the seal cup.  
**Note:** Do not use power tools to remove the plastic seal cup.



**Figure 11-105. Removing the Gearbox Seal Cup**

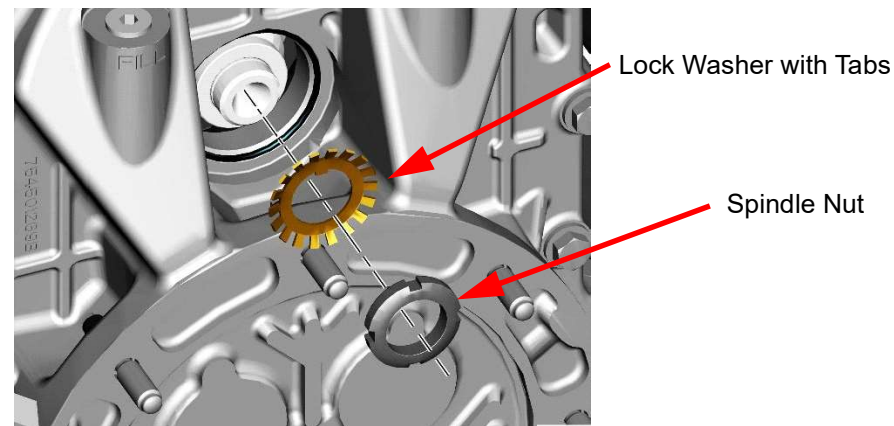
7. Straighten out the tab on the lock washer.



**Figure 11-106. Straightening Tab on Lock Washer**

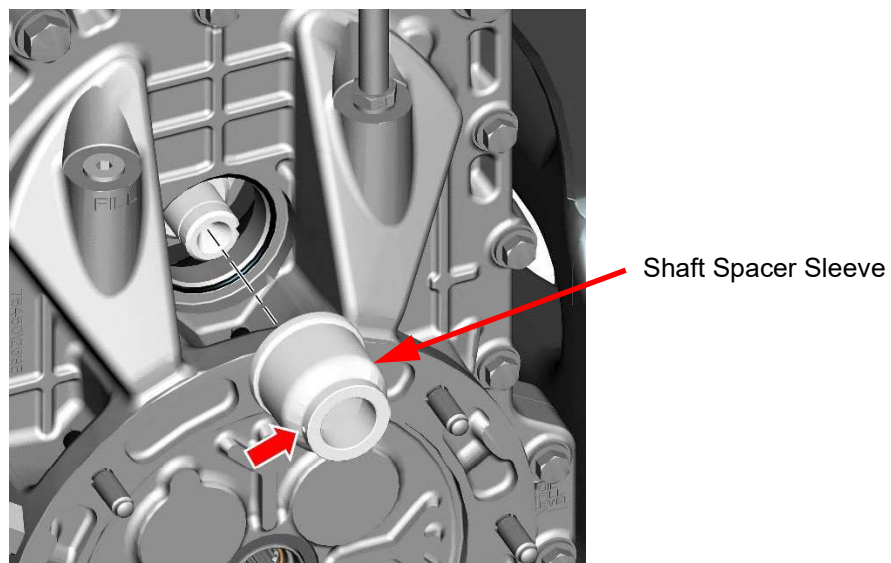
8. Using the spindle nut socket, remove the nut and the lock washer. Discard the lock washer.

**Note:** A light impact may be required to loosen the nut.



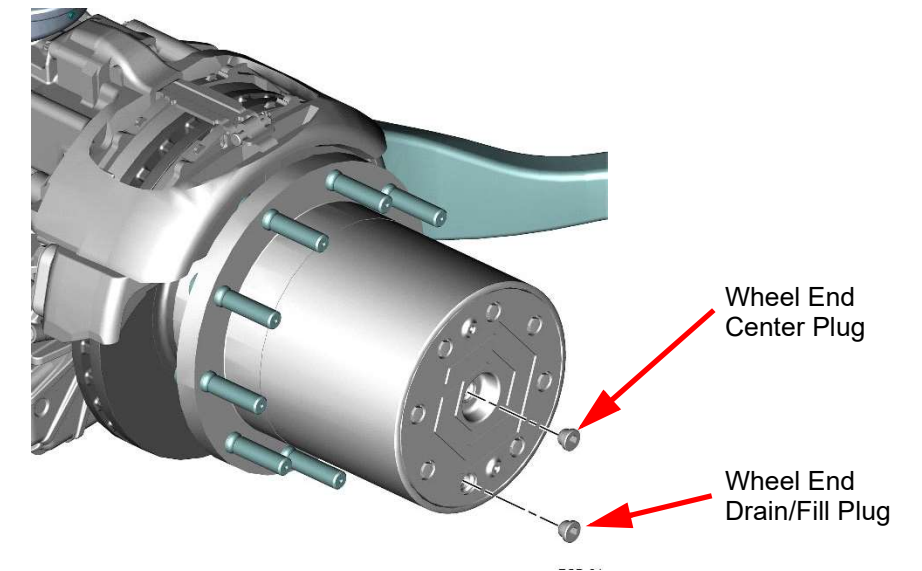
**Figure 11-107. Removing the Spindle Nut and Lock Washer**

9. Locate the small hole in the shaft spacer sleeve and using a pick placed in the hole, remove the shaft spacer sleeve.



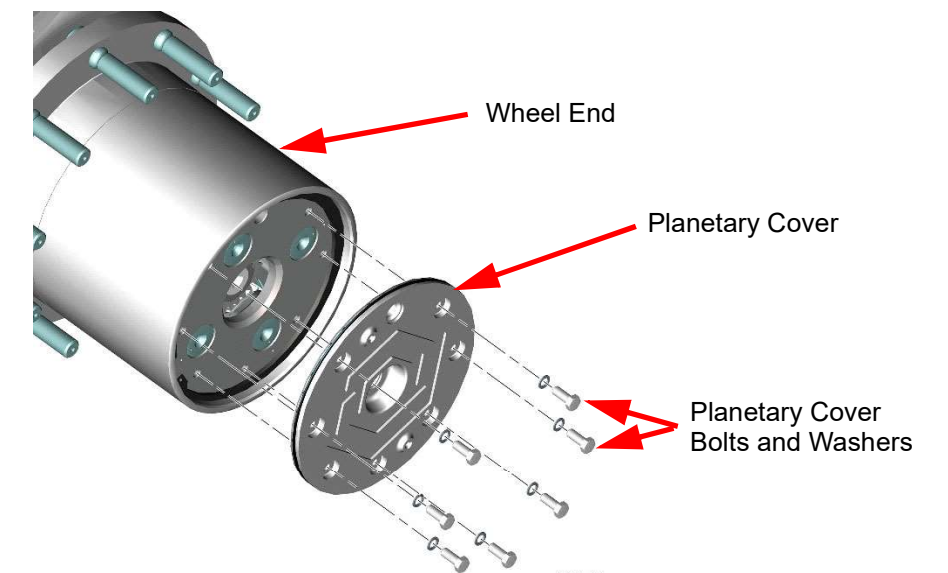
**Figure 11-108. Removing the Shaft Spacer Sleeve**

10. Rotate the wheel end until the outer drain/fill plug is at the 6 o'clock (vertically down) position.
11. Place a suitable catch pan capable of holding 3 quarts of fluid below the hub.
12. Using a 12mm Allen socket, remove the drain/fill plug and center plug to allow the wheel end to drain into the catch pan.



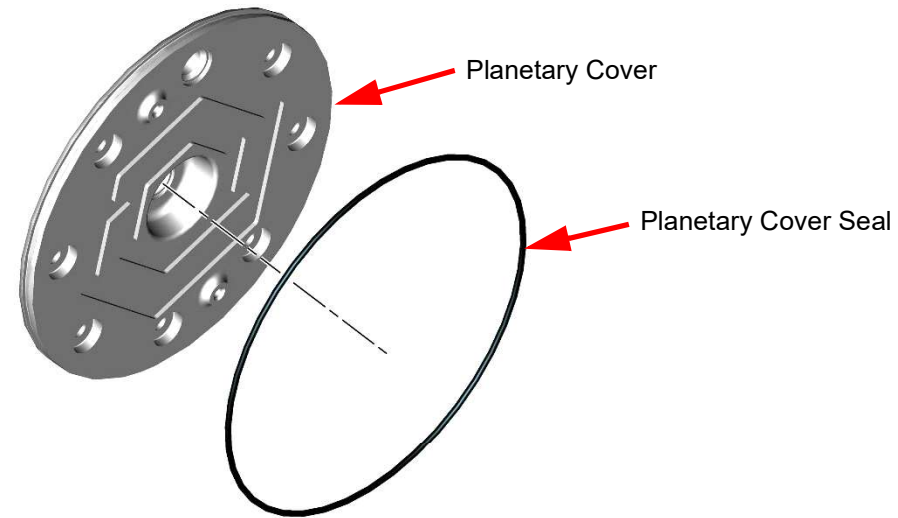
**Figure 11-109. Removing Wheel End Drain/Fill Plug and Center Plug**

13. Using a 16mm socket, remove the bolts, washer seals and planetary cover. Discard the washer seals.



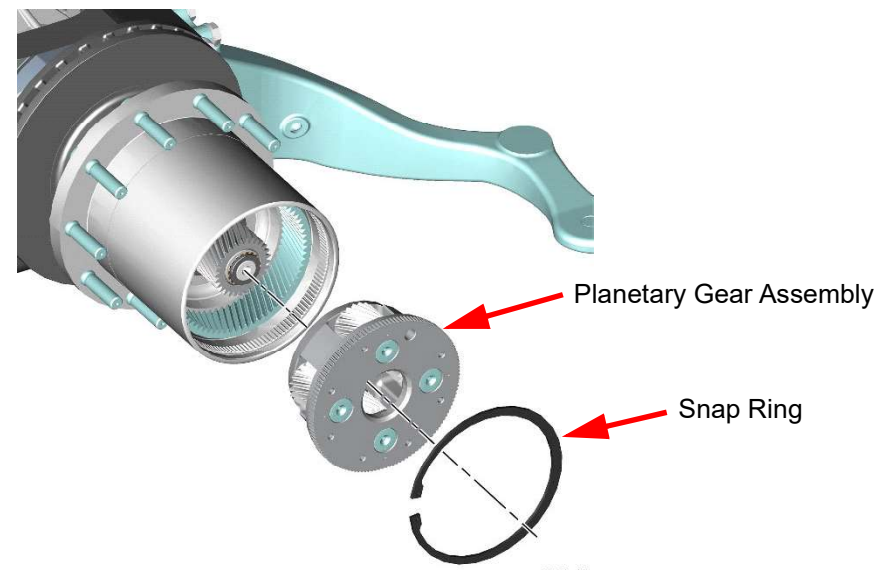
**Figure 11-110. Removing the Planetary Cover**

14. Remove and discard the planetary cover O-ring seal.



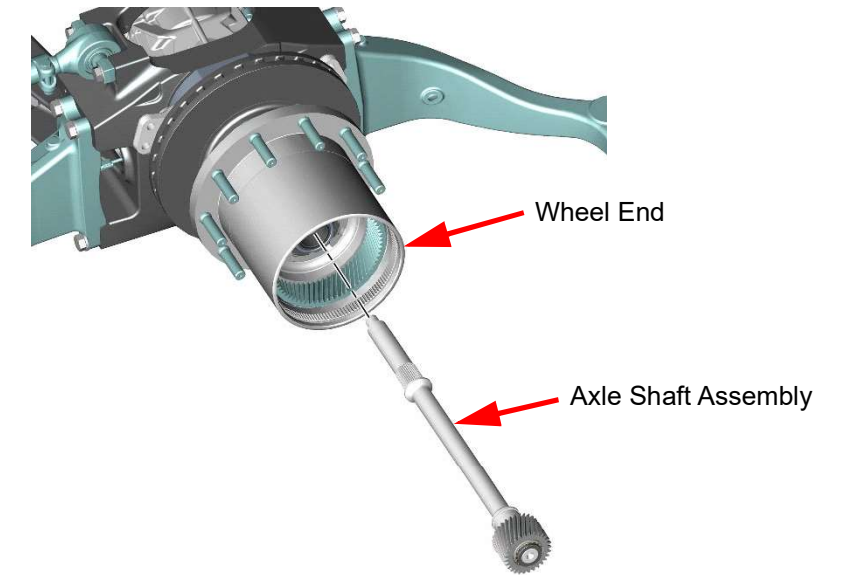
**Figure 11-111. Removing Planetary Cover Seal**

15. Using snap ring pliers, remove the snap ring and the planetary gear assembly.



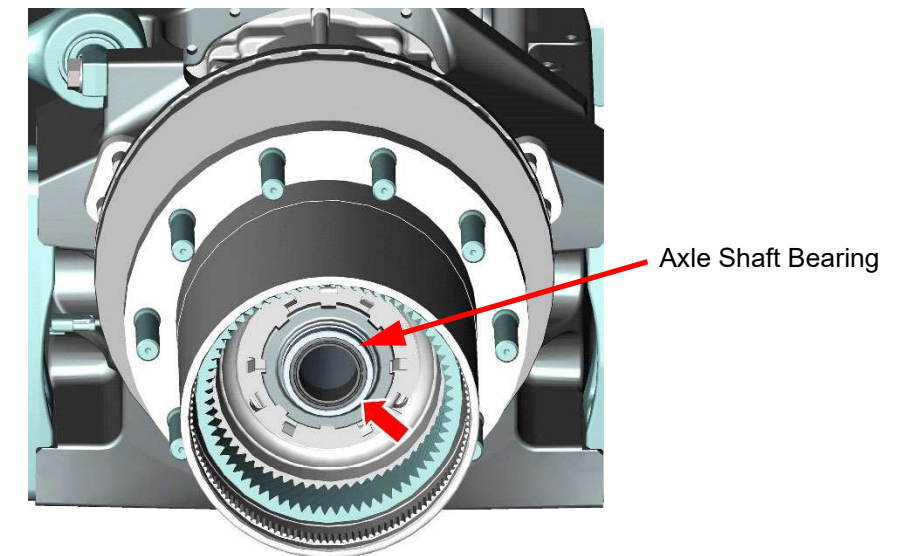
**Figure 11-112. Removing Planetary Gear Assembly**

16. Remove the axle shaft assembly.



**Figure 11-113. Removing Axle Shaft Assembly**

17. Inspect the axle shaft bearing and replace, if needed.  
**Note:** Apply Loctite 680 to the spindle housing.



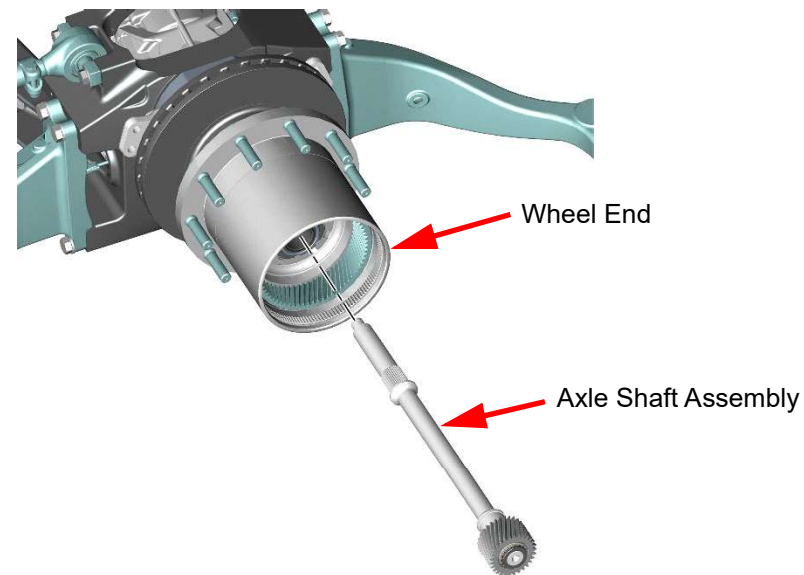
**Figure 11-114. Inspecting Axle Shaft Bearing**

18. Apply US Lube or approved SAE 80W90 oil to the needle bearing prior to installing the axle shaft.

19. Install the axle shaft assembly.



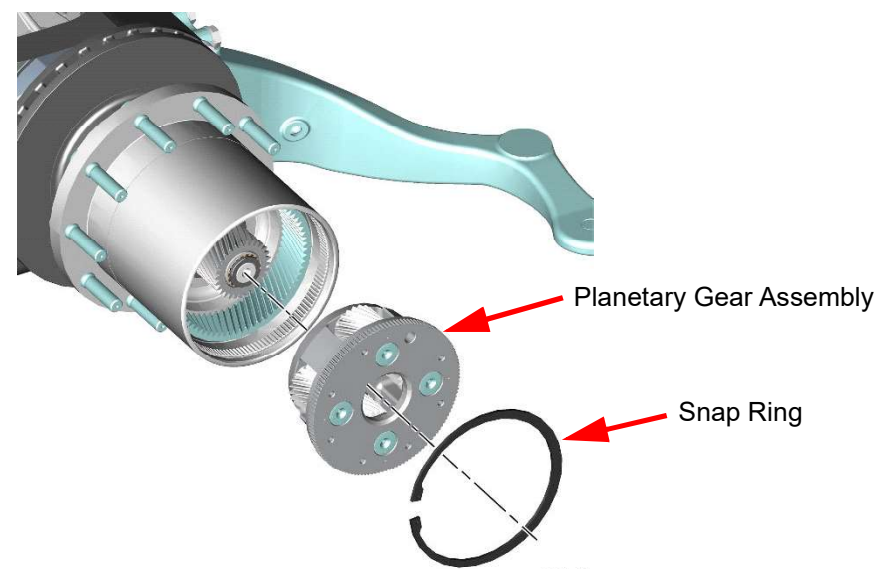
Use extreme care when installing the axle shaft so that the seals are not damaged during installation.



**Figure 11-115. Installing Axle Shaft Assembly**

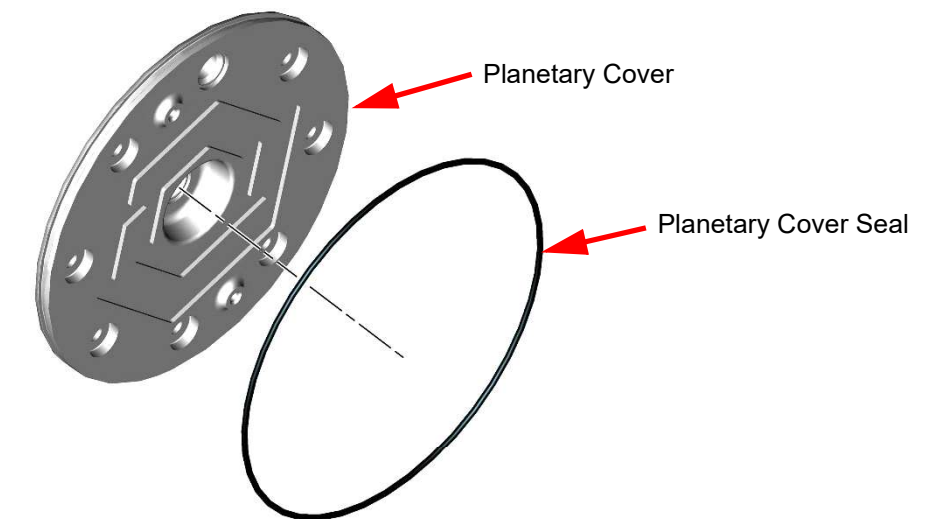
20. Using snap ring pliers, install the planetary gear assembly and snap ring.

**Note:** A soft headed hammer or rubber mallet may be needed to seat the planetary.



**Figure 11-116. Installing Planetary Gear Assembly**

21. Install a new O-ring seal on the planetary cover and lubricate seal with US Lube or other approved SAE 80W90 oil.

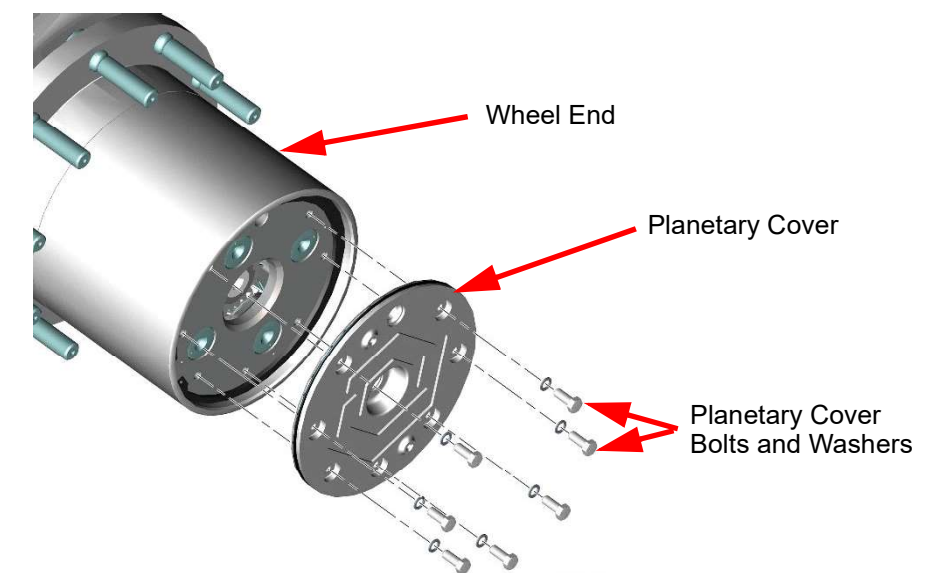


**Figure 11-117. Installing Planetary Cover Seal**

22. Apply Loctite 243 to the threads of the planetary cover bolts.

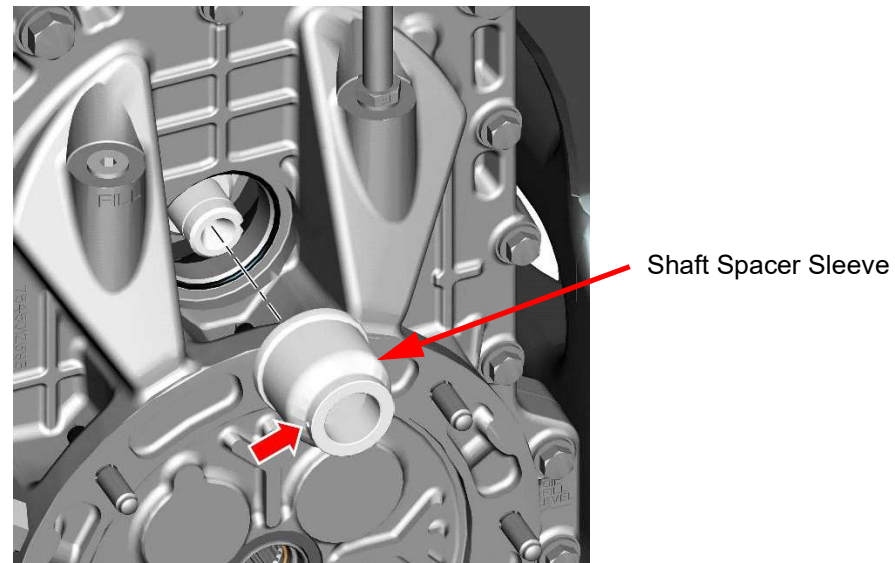
23. Verify the location of the fill hole on the planetary cover in relation to the planetary gear and align.

24. Using a 16mm socket, install new washer seals and the cover bolts securing the planetary cover. **Torque the bolts to 50 ft-lbs (68 Nm).**



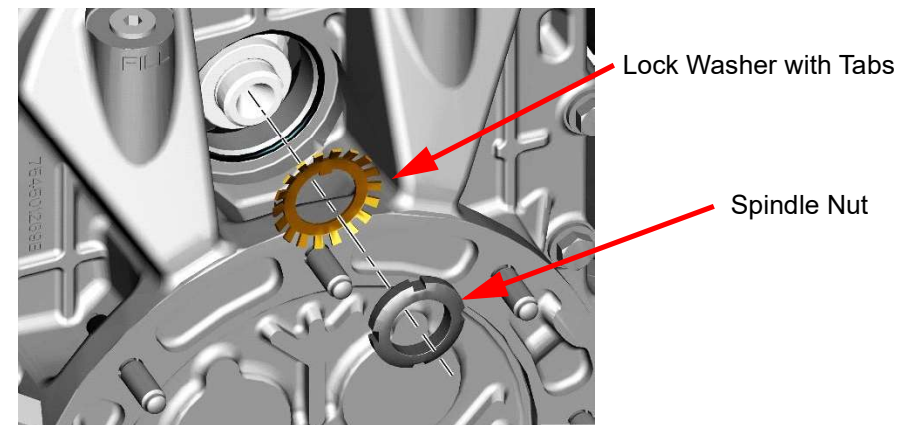
**Figure 11-118. Installing the Planetary Cover**

25. Install the shaft spacer sleeve.



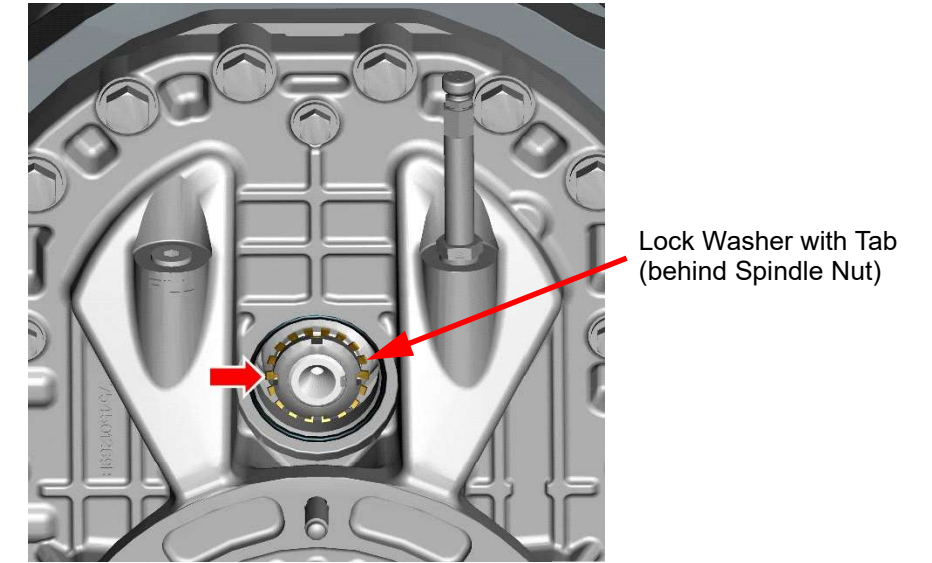
**Figure 11-119. Installing the Shaft Spacer Sleeve**

26. Install the lock washer and the nut. Using the spindle nut socket, **torque the nut to 33 ft-lbs (45 Nm).**  
**Note:** The lock nut should be installed with the chamfer side inboard.



**Figure 11-120. Installing the Spindle Nut and Lock Washer**

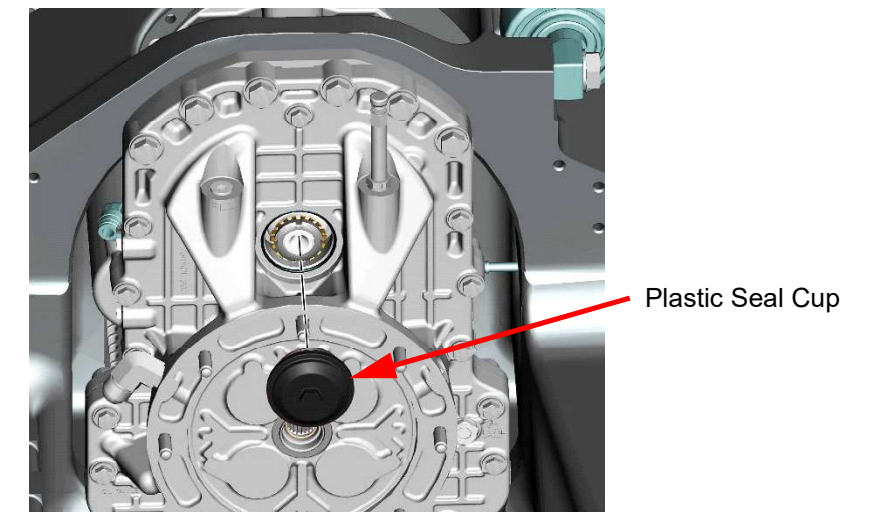
27. Using a tab bending tool, bend over a lock washer tab.  
**Note:** It may be necessary to advance the nut to line up the tab on the lock washer



**Figure 11-121. Bending a Tab on the Spindle Nut Lock Washer**

28. Apply US Lube or approved SAE 80W90 oil to the O-ring seal on the seal cup.

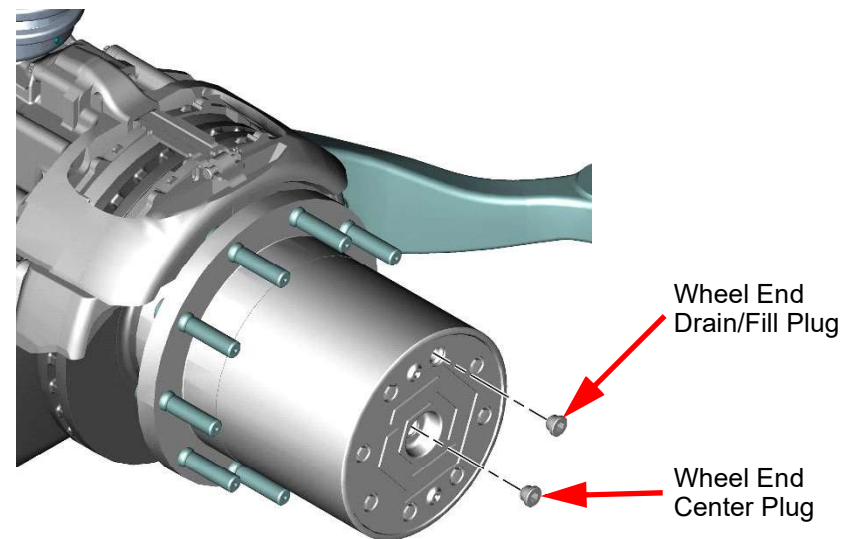
29. Using a 16mm socket with a 6 inch extension, install the seal cup.  
**Torque to 13 ft-lbs (18 Nm).**  
**Note:** Do not use power tools to install the plastic seal cup.



**Figure 11-122. Installing the Gearbox Seal Cup**

30. Check and clean the drain/fill plug and center plug, then lube the O-rings on the plugs with the approved SAE 80W90 oil prior to reinstalling.

31. Rotate the wheel end until the outer drain/fill plug is at the 2 o'clock (vertically up and slightly to the side) position.



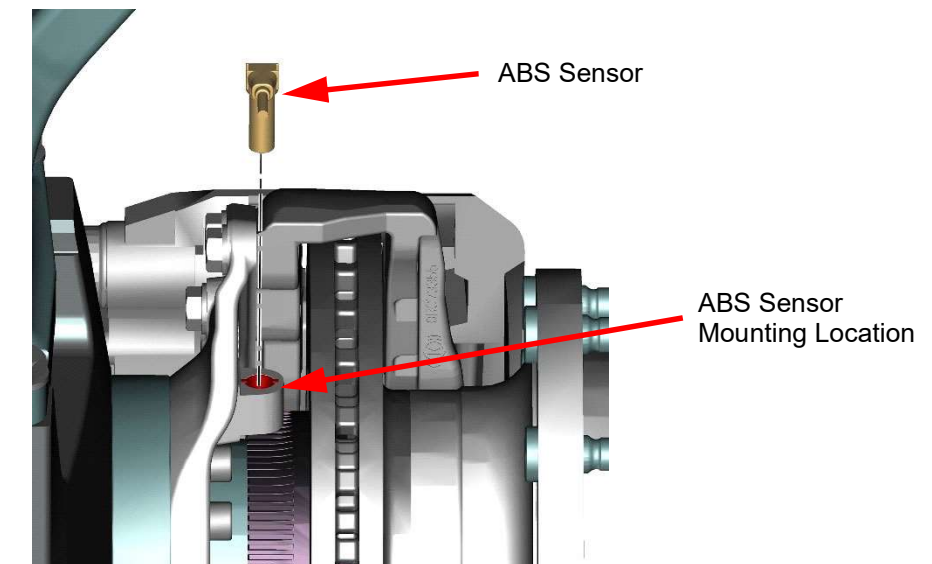
**Figure 11-123. Installing Wheel End Drain/Fill Plug and Center Plug**

32. Fill the wheel end with approved SAE 80W90 oil until the oil flows out of the center hole.
33. Using a 12mm Allen socket, install the center plug and drain/fill plug. **Torque to 22 ft-lbs (30 Nm).**
34. Install the wheels and tires on the side of the axle being serviced.
35. Referencing the Traction Motor Removal and Replacement procedure, install the Traction Motor in the DuoPower Axle.
36. Referencing the DuoPower Axle Removal and Replacement procedure, install the DuoPower Axle in the vehicle.
37. Lower the vehicle off the jack stands and chock the wheels.
38. Set the parking brake and then remove the wheel chocks.
39. Verify proper vehicle operation and complete service documentation, as required.

## Spindle Removal and Replacement

To remove and replace an Axle Shaft, perform the following:

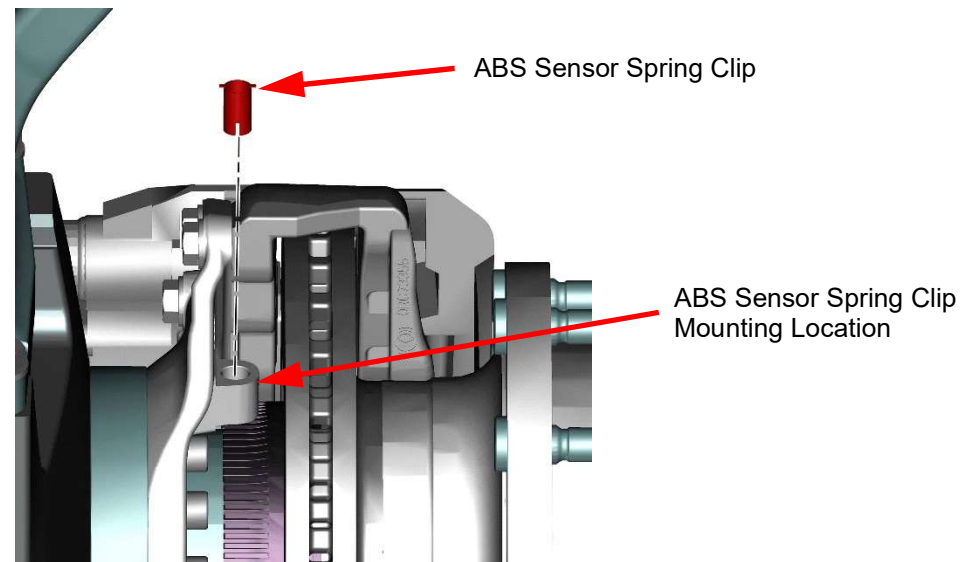
1. Chock the wheels and release the parking brake.
2. Raise and properly support the vehicle using jack stands.
3. Referencing the DuoPower Axle Removal and Replacement procedure, remove the DuoPower Axle from the vehicle.
4. Referencing the Traction Motor Removal and Replacement procedure, remove the Traction Motor from the DuoPower Axle.
5. Remove the wheels and tires from the side of the axle being serviced.
6. Disconnect the ABS (anti-lock brake system) electrical connector.
7. Remove the ABS sensor.



**Figure 11-124. Removing the ABS Sensor**

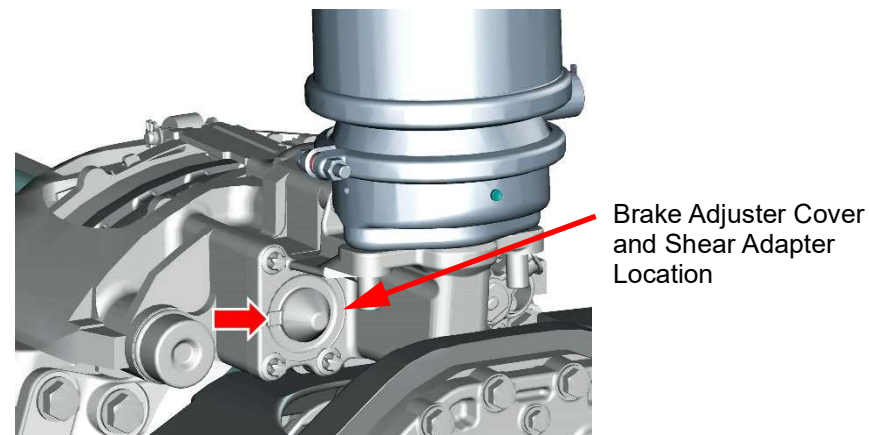
**IMPORTANT!** Replace the Spring Clip with the ABS Sensor when performing this procedure.

8. Remove and discard the ABS sensor spring clip.



**Figure 11-125. Removing the ABS Sensor Spring Clip**

9. Remove the brake adjuster cover and place aside.



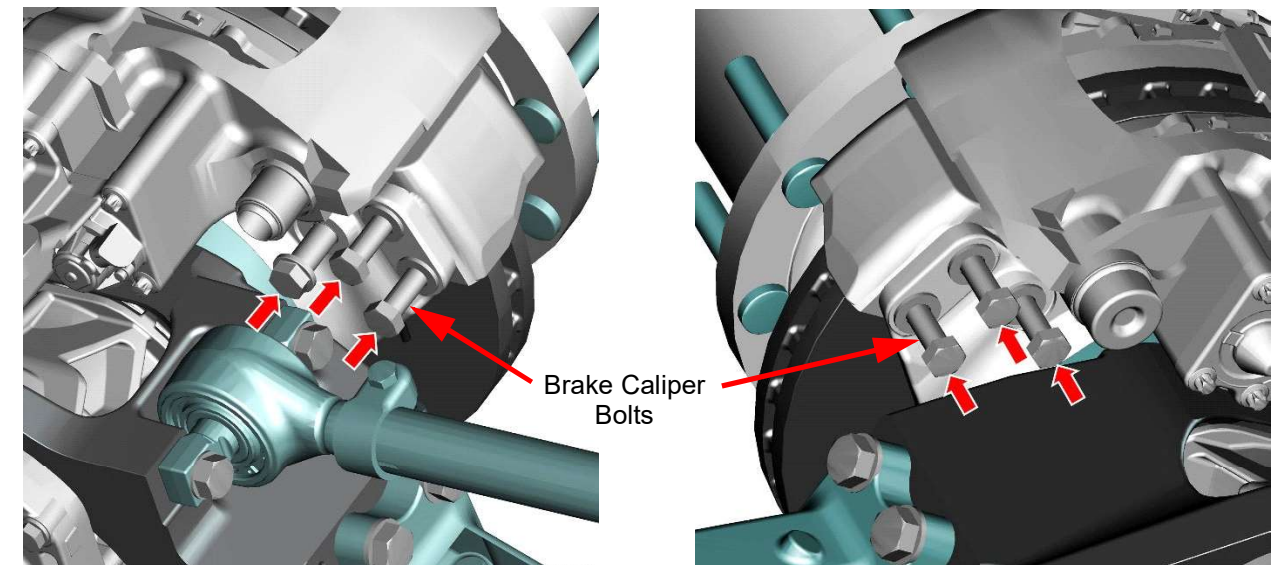
**Figure 11-126. Removing the Brake Adjuster Cover**

10. Using the shear adapter, back off the brakes.

**NOTICE!** If two shear adapters fail while attempting to back off the brakes, install a new brake caliper as internal damage may be present in the brake caliper.

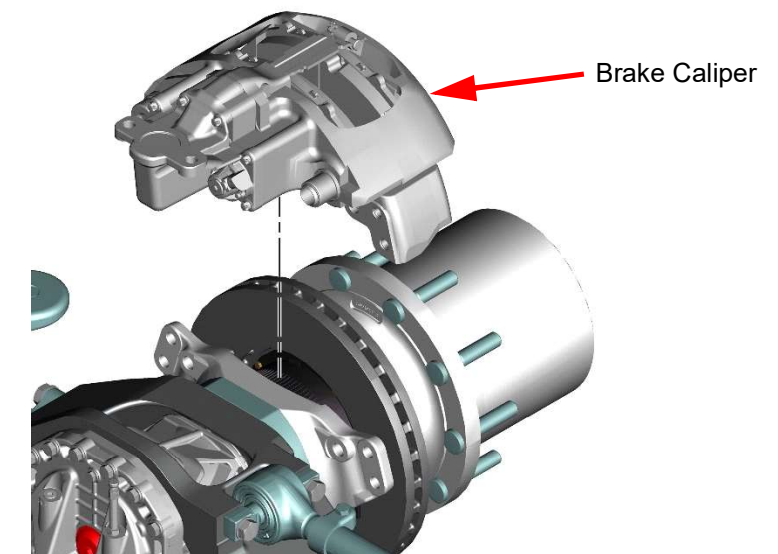
11. Disconnect the brake lining wear sensor electrical connector.

12. Using the dog bone tool TC-80411, loosen the brake caliper bolts.
  - Note:** Leave the bolts in the bracket after removing the brake caliper.
  - a. Shoulder pin bolt: M16x1.50x58/19-10.9 HHCS (no washer, qty. 1)
  - b. Inner bolt: M16x1.50x60/35-10.9 (qty. 1)
  - c. Outer bolts: M16x1.50x45/45-10.9 PHOS (qty. 4)



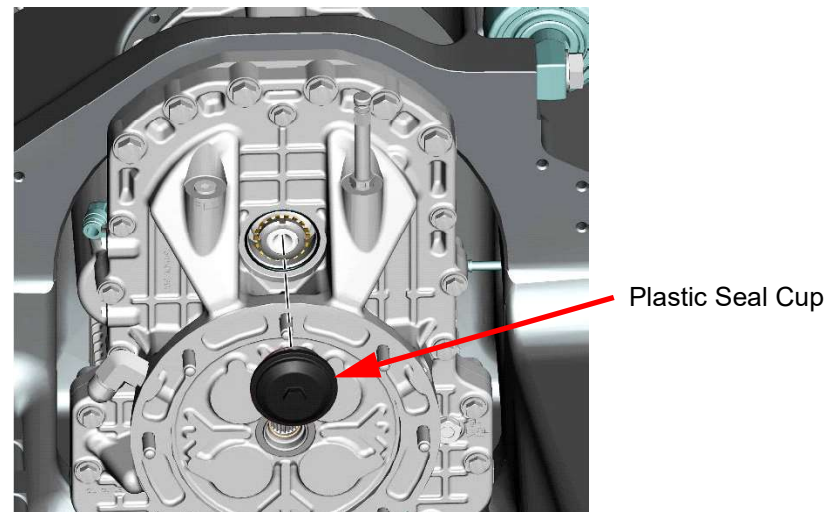
**Figure 11-127. Removing the Brake Caliper Bolts**

13. Remove the brake caliper.



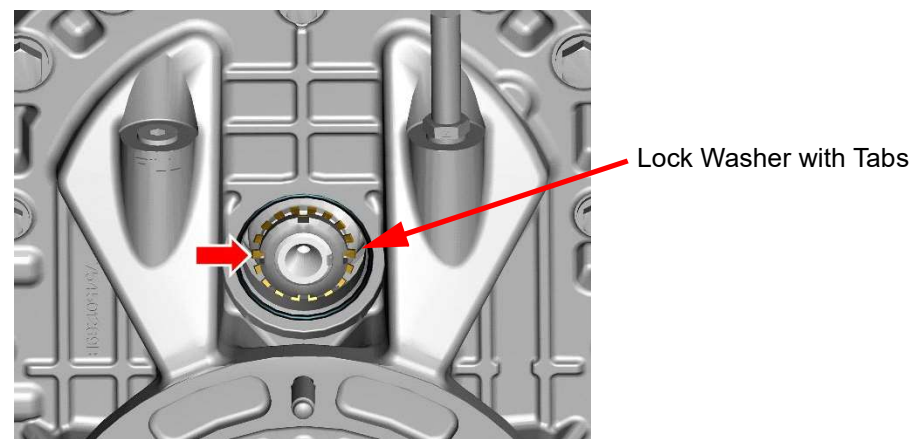
**Figure 11-128. Removing the Brake Caliper**

14. Using a 16mm socket, remove and discard the seal cup.  
**Note:** Do not use power tools to remove the plastic seal cup.



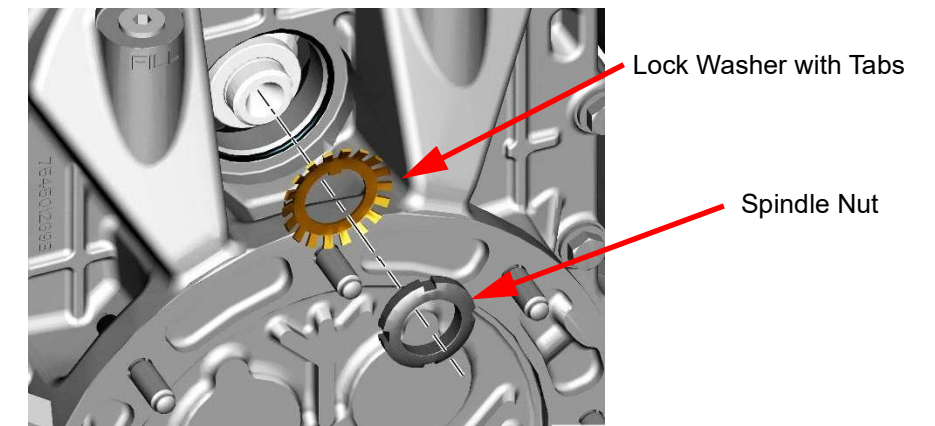
**Figure 11-129. Removing the Gearbox Seal Cup**

15. Straighten out the tab on the lock washer.



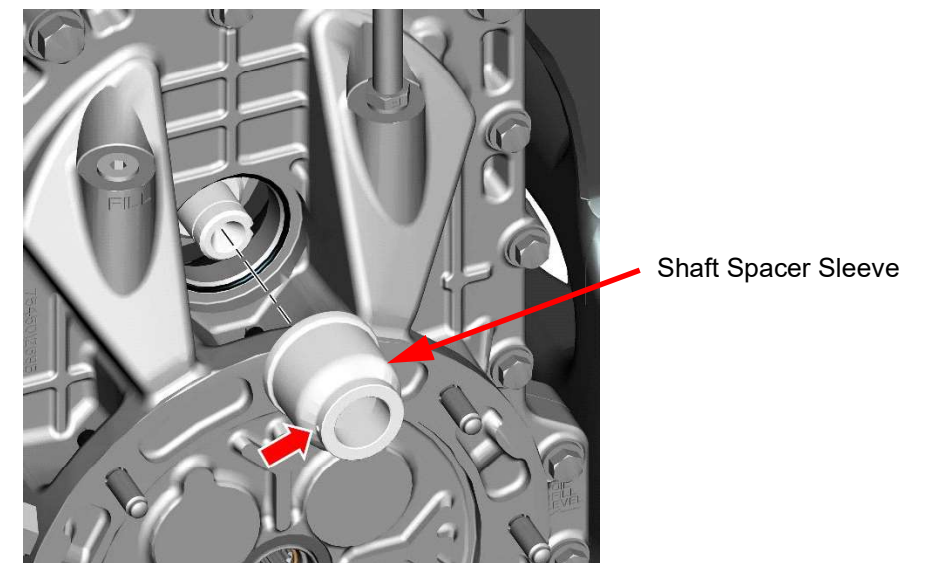
**Figure 11-130. Straightening Tab on Lock Washer**

16. Using the spindle nut socket, remove the nut and the lock washer.  
 Discard the lock washer.  
**Note:** A light impact may be required to loosen the nut.



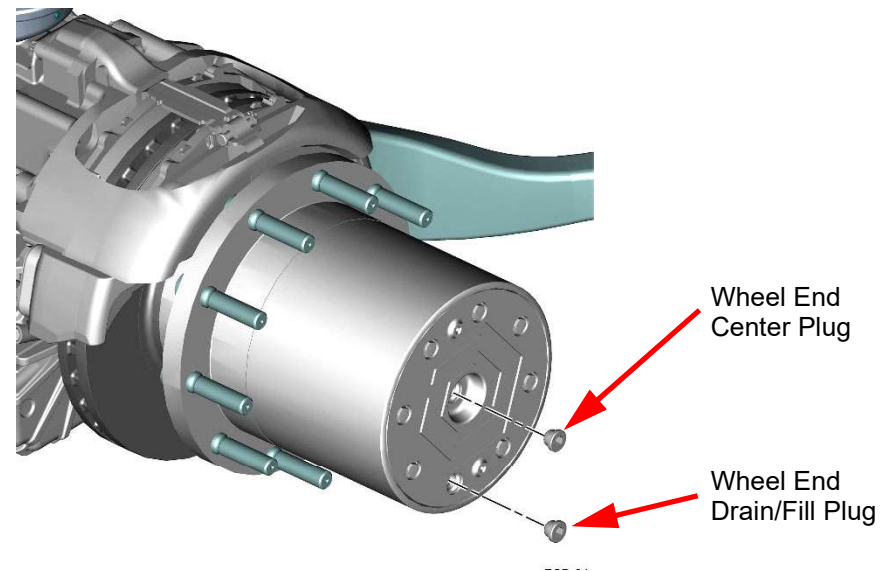
**Figure 11-131. Removing the Spindle Nut and Lock Washer**

17. Locate the small hole in the shaft spacer sleeve and using a pick placed in the hole, remove the shaft spacer sleeve.



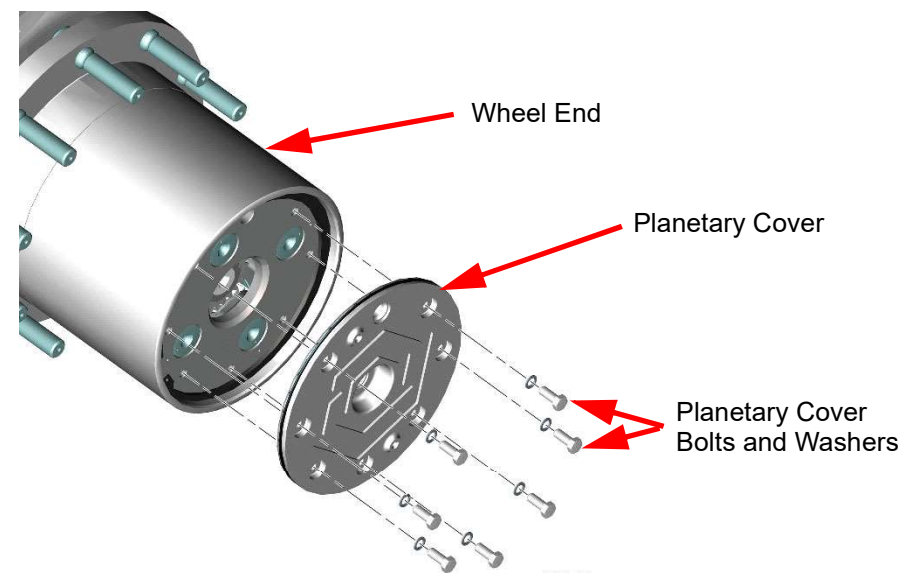
**Figure 11-132. Removing the Shaft Spacer Sleeve**

18. Rotate the wheel end until the outer drain/fill plug is at the 6 o'clock (vertically down) position.
19. Place a suitable catch pan capable of holding 3 quarts of fluid below the hub.
20. Using a 12mm Allen socket, remove the drain/fill plug and center plug to allow the wheel end to drain into the catch pan.



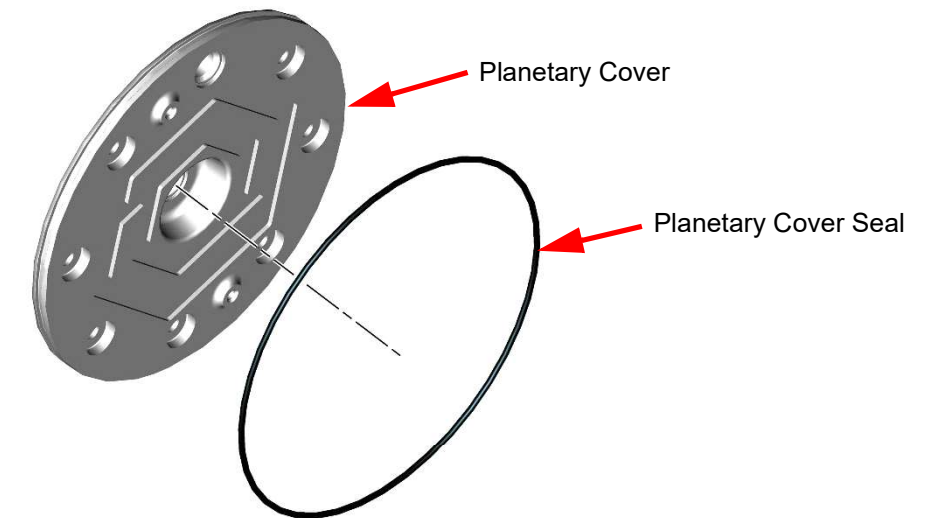
**Figure 11-133. Removing Wheel End Drain/Fill Plug and Center Plug**

21. Using a 16mm socket, remove the bolts, washer seals and planetary cover. Discard the washer seals.



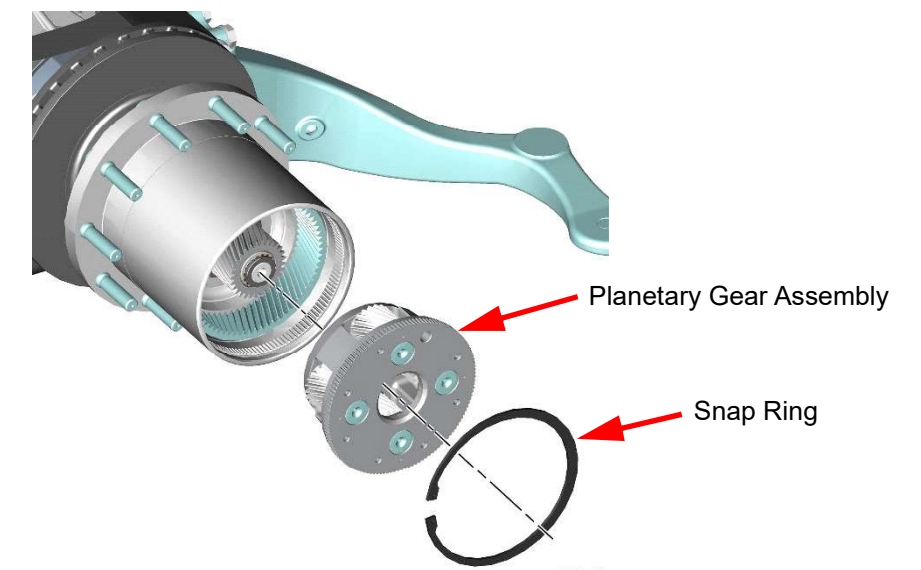
**Figure 11-134. Removing the Planetary Cover**

22. Remove and discard the planetary cover O-ring seal.



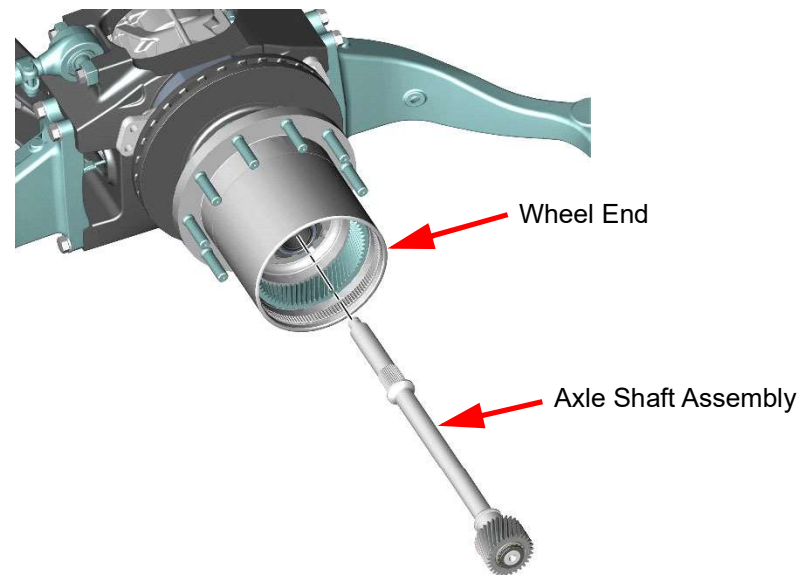
**Figure 11-135. Removing Planetary Cover Seal**

23. Using snap ring pliers, remove the snap ring and the planetary gear assembly.



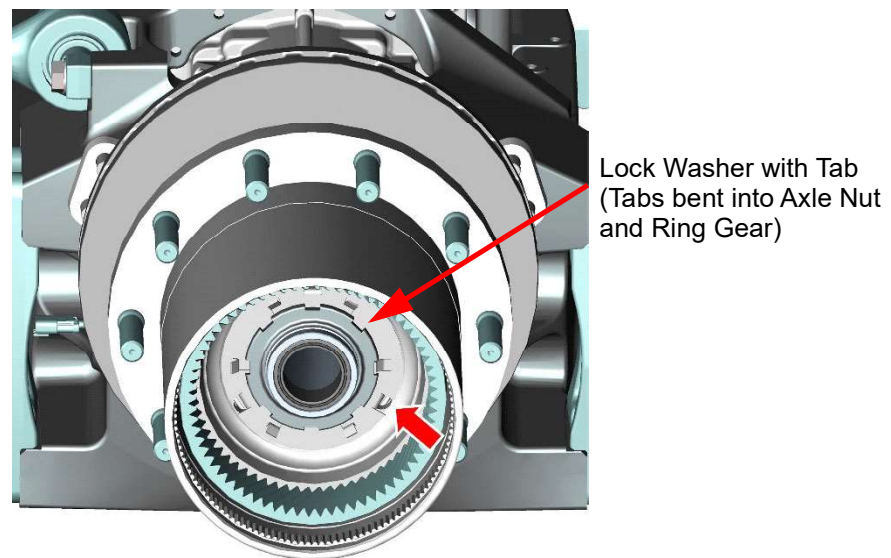
**Figure 11-136. Removing Planetary Gear Assembly**

24. Remove the axle shaft assembly.



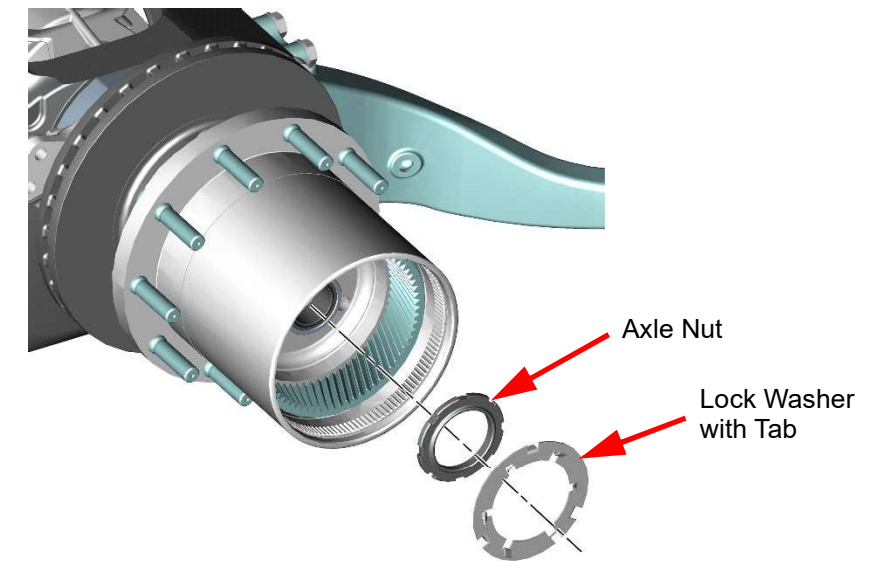
**Figure 11-137. Removing Axle Shaft Assembly**

25. Straighten out the tab on the axle nut lock washer.



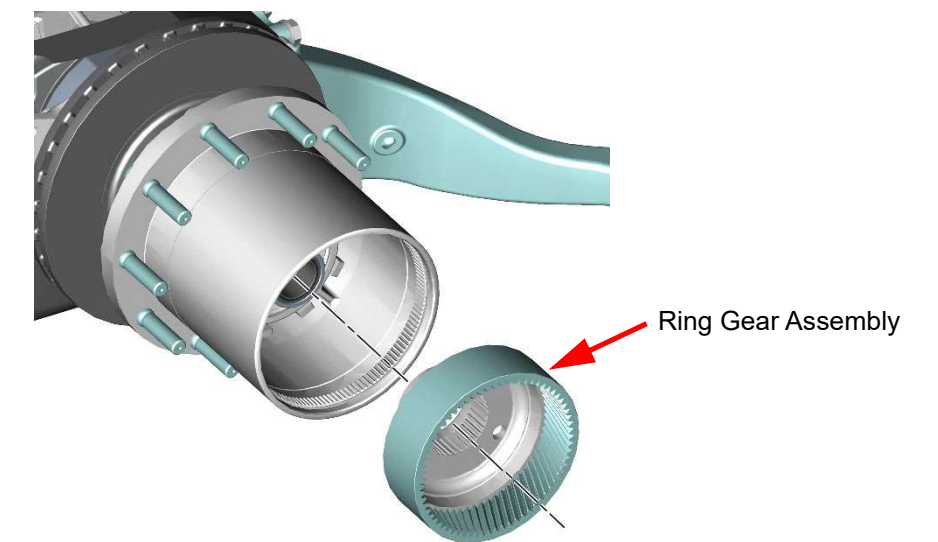
**Figure 11-138. Straightening Tab on Axle Nut Lock Washer**

26. Remove the axle nut and the lock washer. Discard the lock washer.



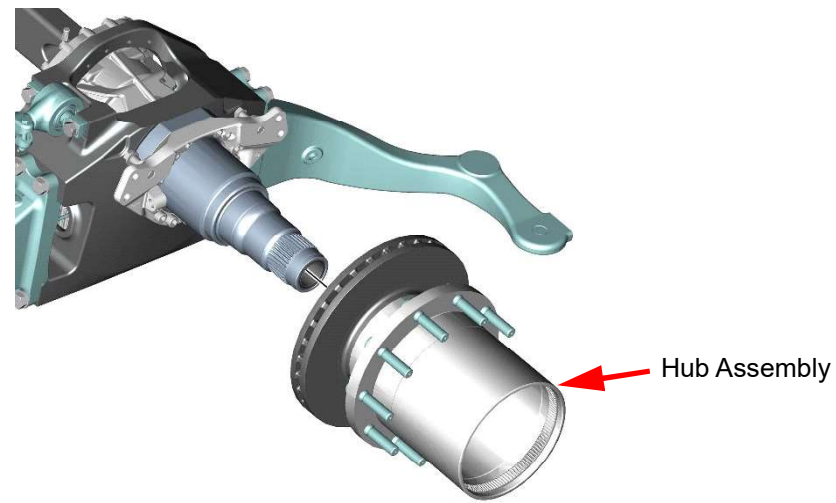
**Figure 11-139. Removing Axle Nut and Lock Washer**

27. Remove the ring gear assembly and inspect the axle bearing.



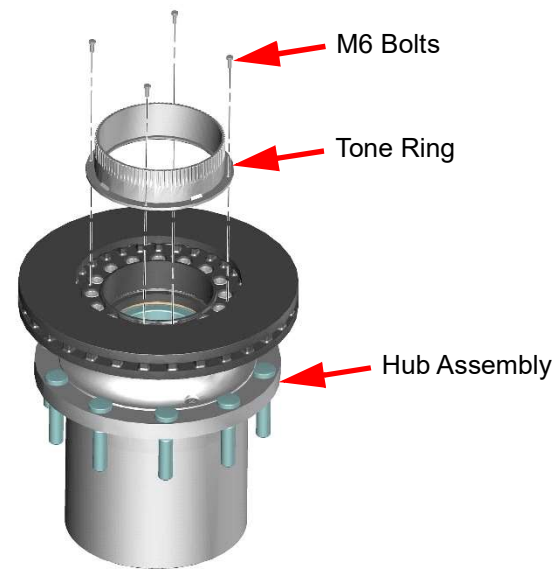
**Figure 11-140. Removing Ring Gear Assembly**

28. Using a properly rated lifting device, remove the hub assembly and place on a work bench.



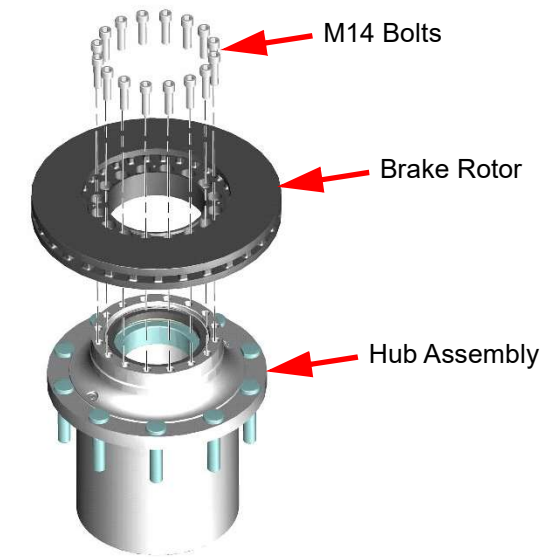
**Figure 11-141. Removing Hub Assembly**

29. Using a 10mm socket, remove the bolts securing the ABS (anti-lock brake sensor) tone ring and remove the tone ring from the hub assembly.



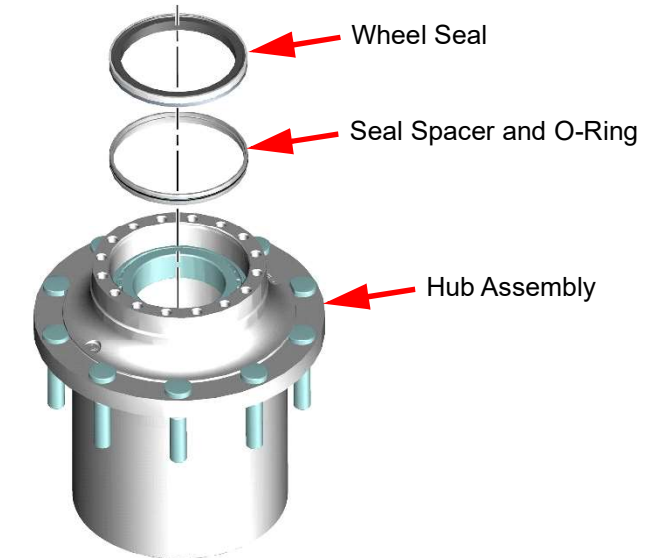
**Figure 11-142. Removing Tone Ring from Hub Assembly**

30. Using a 12mm Allen socket, remove the bolts securing the Brake Rotor and remove the brake rotor from the hub assembly.



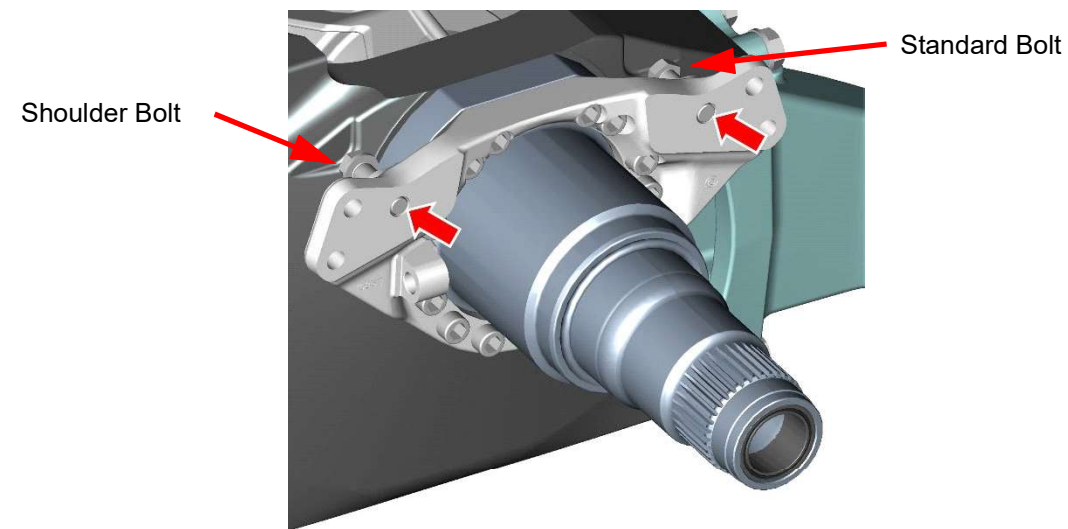
**Figure 11-143. Removing Brake Rotor from Hub Assembly**

31. Remove and discard the wheel seal, seal spacer, and O-ring. Then remove and inspect the axle bearing.



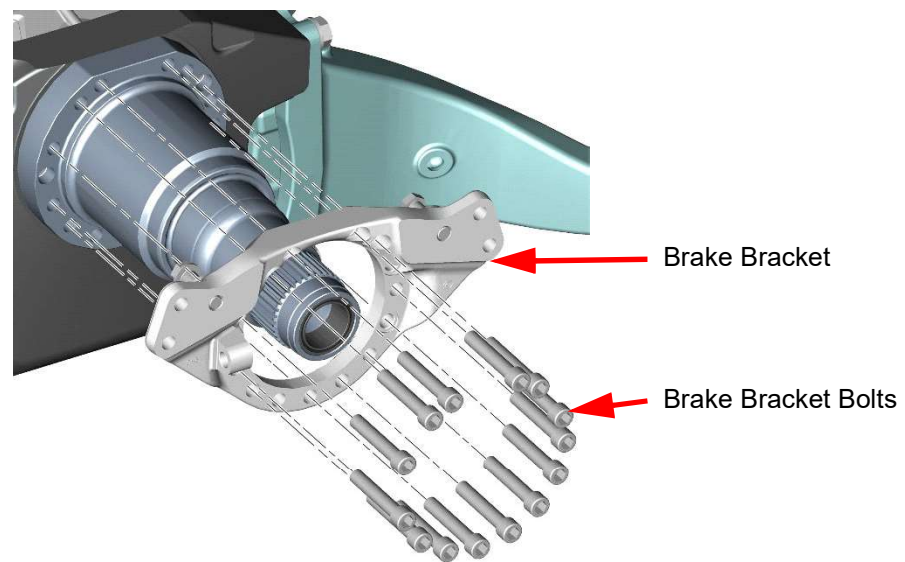
**Figure 11-144. Removing Wheel Seal, Seal Spacer, and O-Ring from Hub Assembly**

32. Note the location of the shoulder bolt and the standard bolt that remain in the brake bracket.



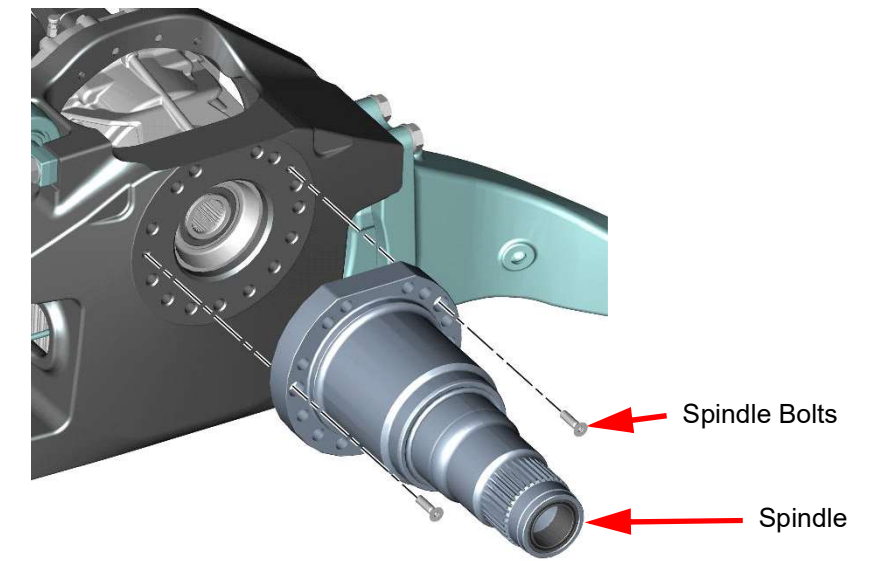
**Figure 11-145. Locating Shoulder Bolt and Standard Bolt Positions**

33. Using a 14mm Allen socket, remove the brake bracket bolts and the brake bracket.



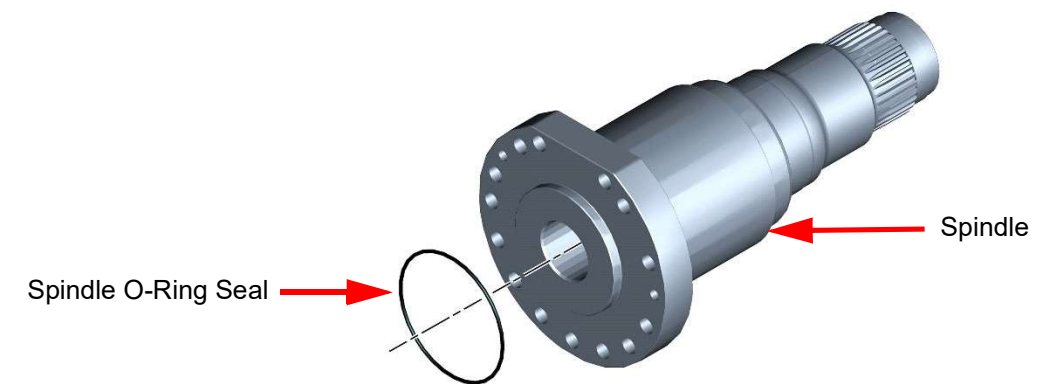
**Figure 11-146. Removing the Brake Bracket**

34. Using a 14mm Allen socket, remove the spindle bolts and the spindle.



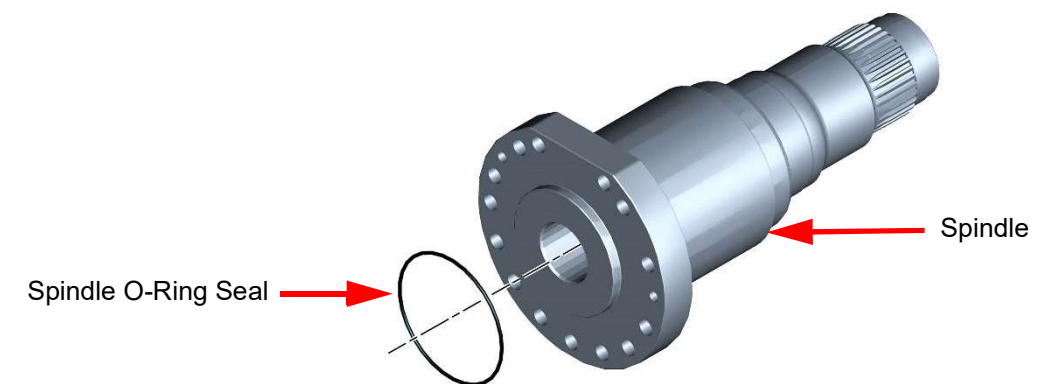
**Figure 11-147. Removing the Spindle**

35. Remove and discard the O-ring seal on the back of the spindle.



**Figure 11-148. Removing the Spindle O-Ring Seal**

36. Install the new O-ring seal on the (existing or replacement) spindle and apply a light coat of US Lube or approved SAE 80W90 oil.

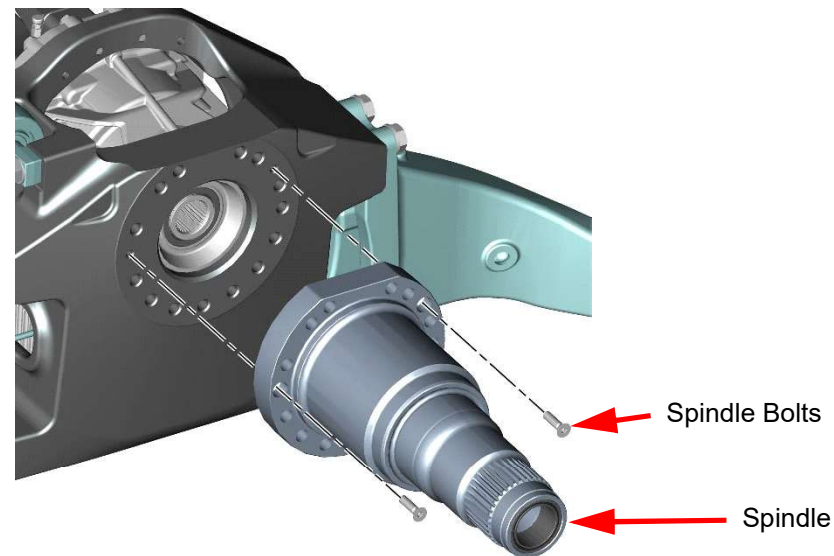


**Figure 11-149. Installing the Spindle O-Ring Seal**

37. Apply Loctite 243 to the threads of the spindle bolts and using a 14mm Allen socket, install the spindle and the spindle bolts. **Torque the bolts to 18 ft-lbs (24 Nm).**

**NOTICE:** To aid in installation, use locally sourced guide pins or studs.

- Bolts: M16x2.00x90/44-10.9 SHCS (qty. 2)

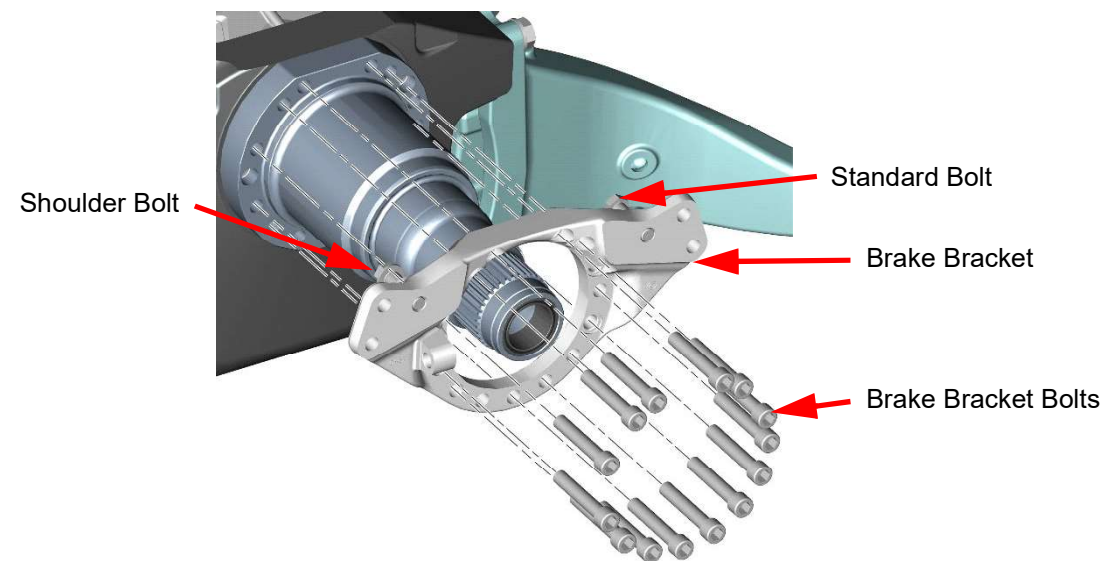


**Figure 11-150. Installing the Spindle**

38. Verify position of shoulder bolt and standard bolt and ensure the brake bracket bolts are installed in the same position as removed.

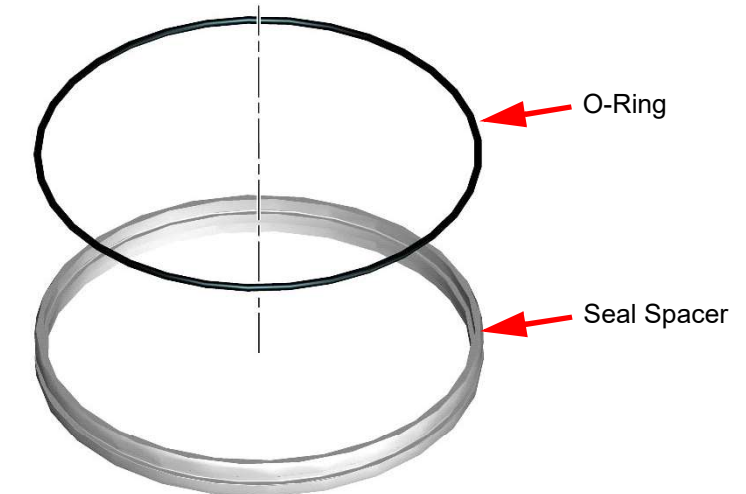
39. Apply Loctite 243 to the threads of the brake bracket bolts and using a 14mm Allen socket, install the brake bracket and the bolts. **Torque the bolts to 229 ft-lbs (310 Nm).**

- Bolts: M16x2.00x90/44-10.9 SHCS (qty. 14)



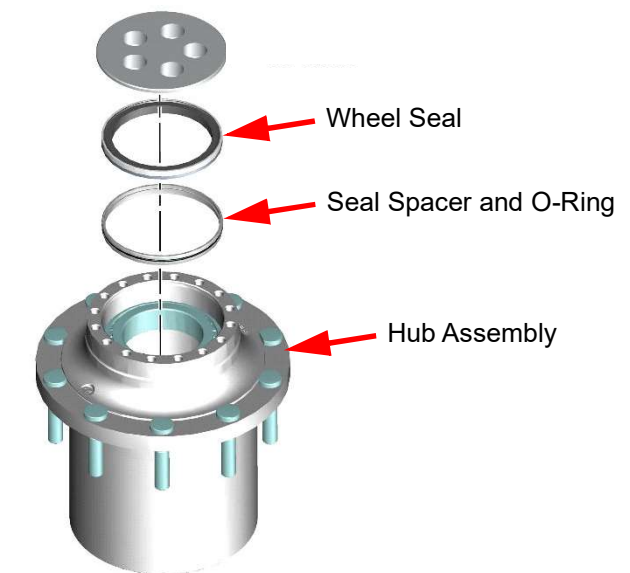
**Figure 11-151. Installing the Brake Bracket**

40. Install the new O-ring seal onto the new seal spacer.



**Figure 11-152. Installing O-Ring onto Seal Spacer**

41. Apply US Lube or other approved SAE 80W90 oil to the axle bearing seal bore and bearing cone and then install the axle bearing into the hub.



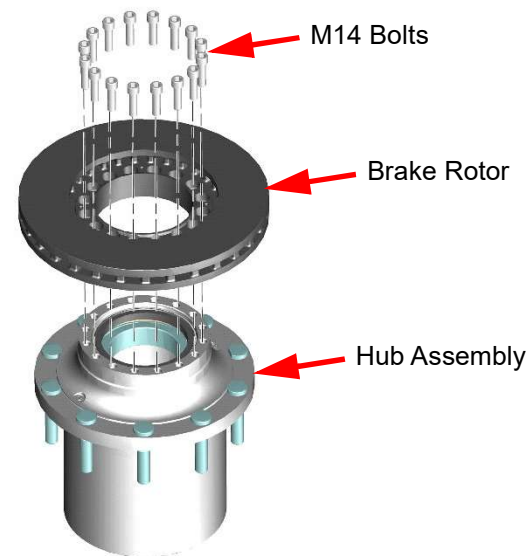
**Figure 11-153. Installing Axle Bearing, Wheel Seal, Seal Spacer (with O-Ring) into Hub Assembly**

42. Position the seal spacer (with O-ring) into the hub, and using an appropriate size seal driver press the seal spacer into the hub.

43. Position the wheel seal into the hub, and using an appropriate size seal driver press the wheel seal into the hub.

44. Using a 12mm Allen socket, install the brake rotor and bolts onto the hub assembly. **Torque the bolts to 155 ft-lbs (210 Nm).**

- Bolts: M14x1.50x50/40-10.9 SHCS Patch (qty. 16)

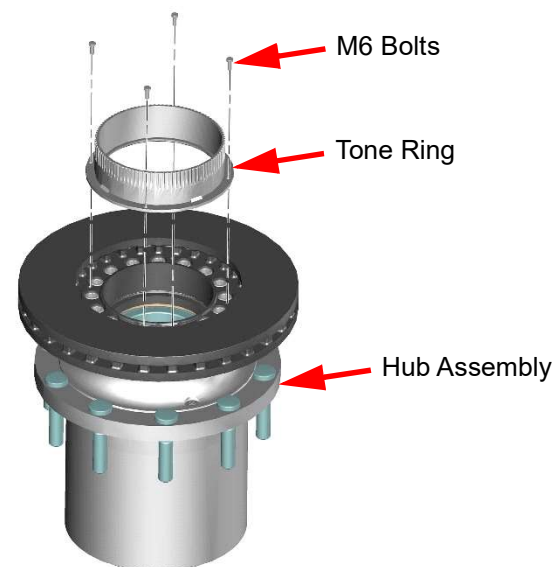


**Figure 11-154. Installing Brake Rotor onto Hub Assembly**

45. Apply Loctite 243 to the threads of the M6 bolts used to secure the Tone Ring.

46. Using a 10mm socket, install the ABS (anti-lock brake sensor) tone ring and bolts into the hub assembly. **Torque the bolts to 11 ft-lbs. (15 Nm).**

- Bolts: M6x1.00x16/16-10.9 HHCS (qty. 4)

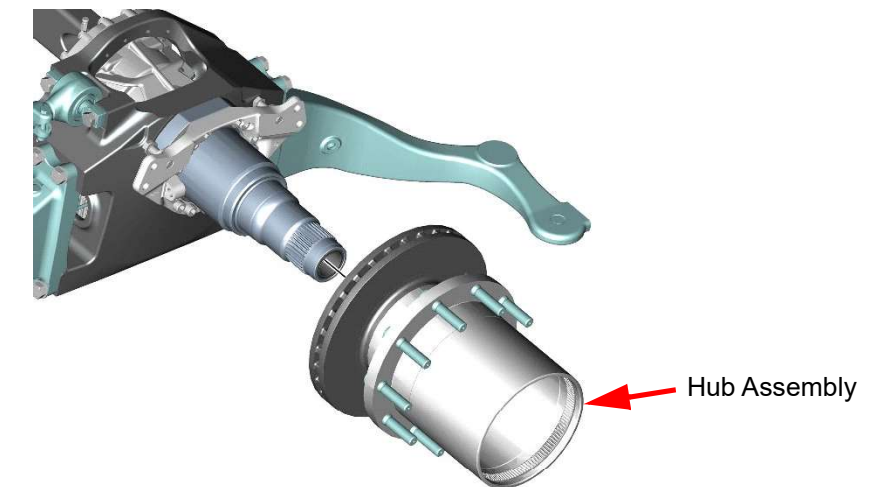


**Figure 11-155. Installing Tone Ring onto Hub Assembly**

47. Using a properly rated lifting device, carefully position the hub assembly on the spindle.

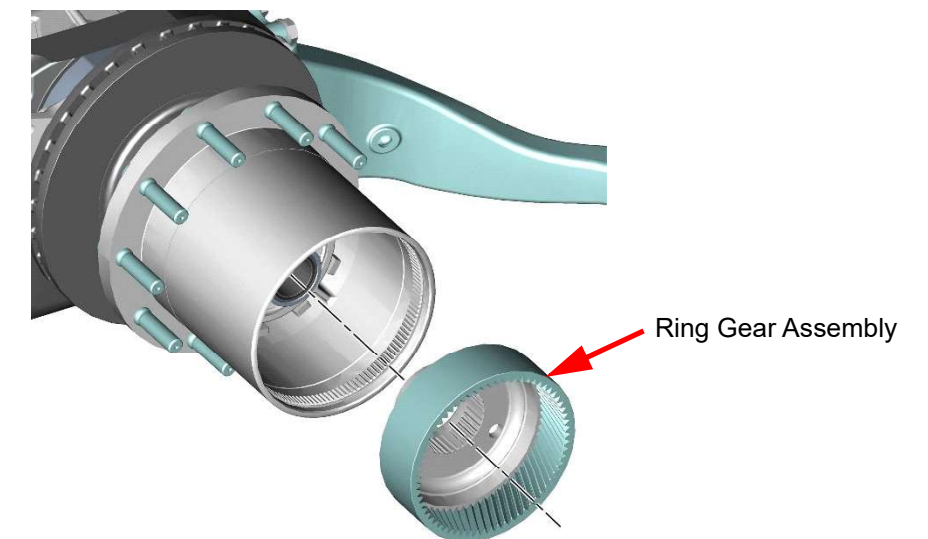


**CAUTION** Use extreme care to ensure that the wheel seal does not hit the spindle while positioning and installing the hub assembly. Damage to the wheel seal can occur if allowed to hit the spindle.



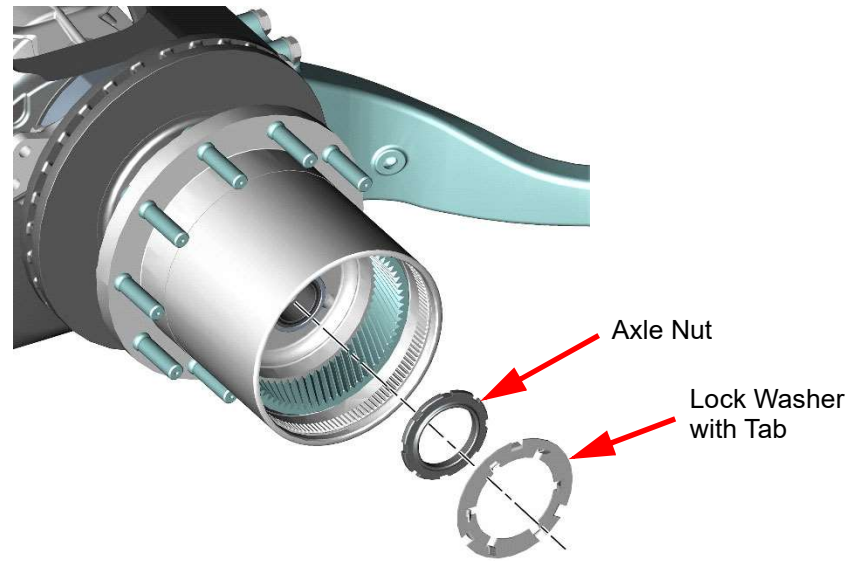
**Figure 11-156. Installing Hub Assembly**

48. Apply US Lube or other approved SAE 80W90 oil to the axle bearing and then install the ring gear assembly into the hub assembly.



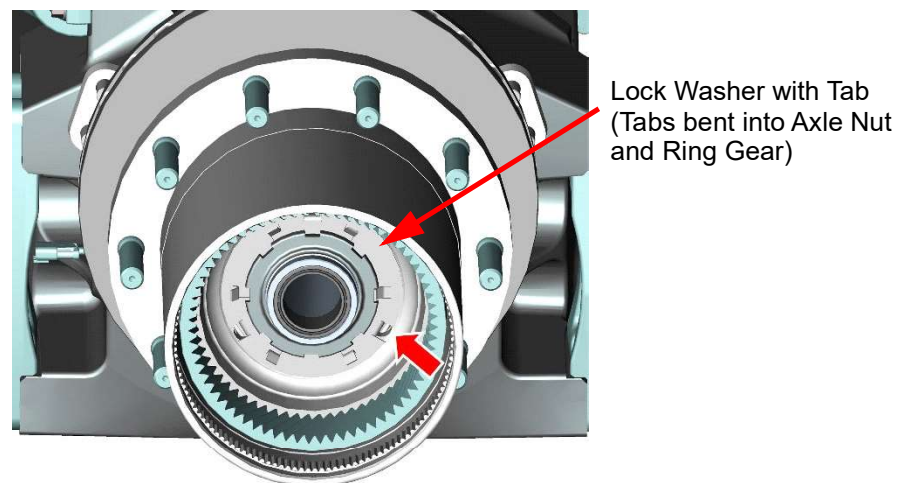
**Figure 11-157. Installing Ring Gear Assembly**

49. Install the new lock washer into the ring gear with three tabs bent down into the holes on the ring gear.



**Figure 11-158. Installing Axle Nut and Lock Washer**

50. Apply a small amount of “never seize” on the threads of the axle nut and hand start on the spindle. **Torque the axle nut to 450 ft-lbs (610 Nm).**
51. Spin the hub assembly in both directions. Strike the hub with an 8 pound weight to seat the bearing. **Torque the axle nut a second time to 450 ft-lbs (610 Nm).**
52. Spin the hub assembly in both directions. Back off the axle nut. **Torque the axle nut to 290 ft-lbs (393 Nm).**  
**Note: Torque as needed to align tabs, not exceeding 345 ft-lbs (468 Nm).**
53. Using a tab bending tool, bend over two tabs into axle nut slots.



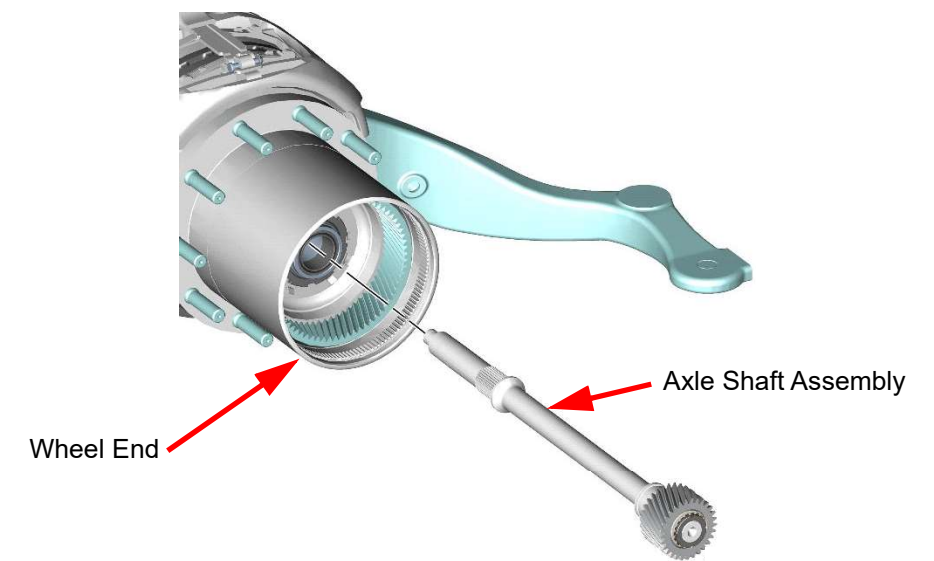
**Figure 11-159. Bending Tabs on Axle Nut Lock Washer**

54. Apply US Lube or approved SAE 80W90 oil to the needle bearing prior to installing the axle shaft.

55. Install the axle shaft assembly.

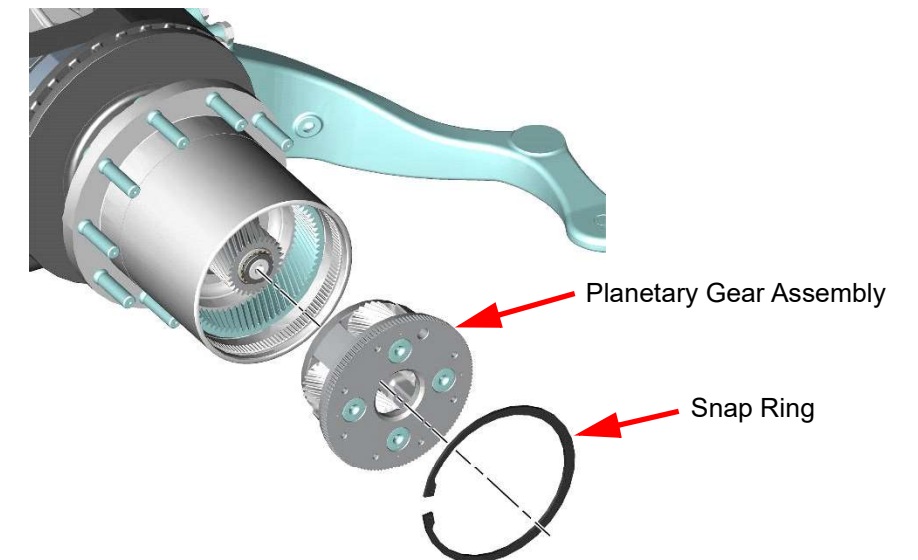


Use extreme care when installing the axle shaft so that the seals are not damaged during installation.



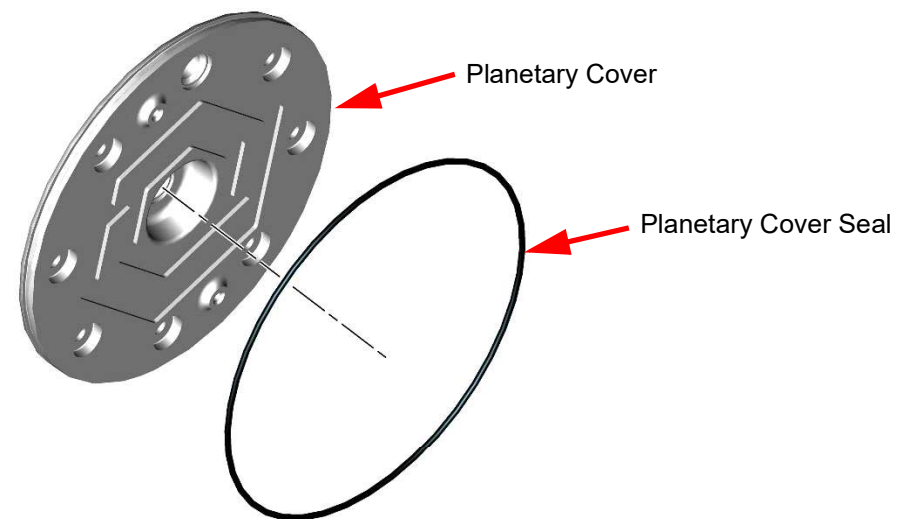
**Figure 11-160. Installing Axle Shaft Assembly**

56. Using snap ring pliers, Install the planetary gear assembly and snap ring.  
**Note: A soft headed hammer or rubber mallet may be needed to seat the planetary.**



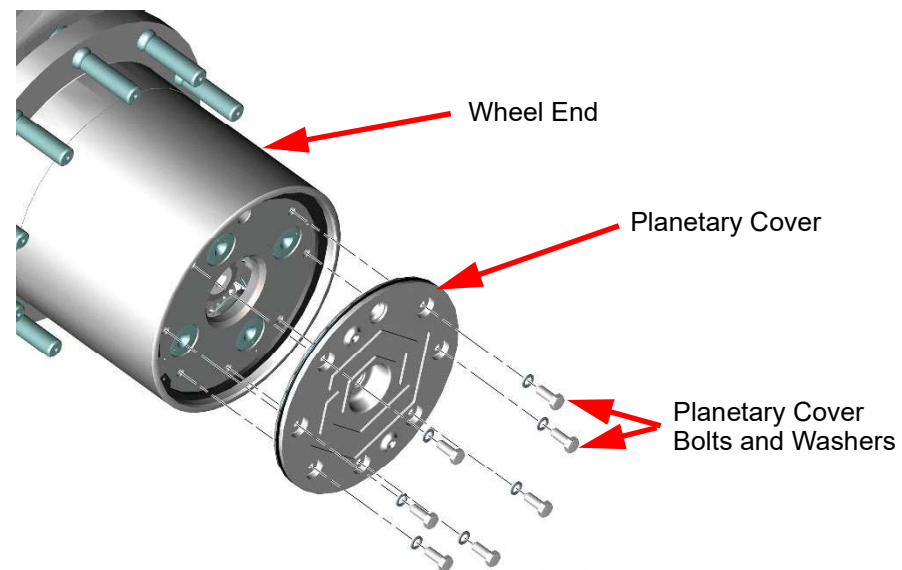
**Figure 11-161. Installing Planetary Gear Assembly**

57. Install a new O-ring seal on the planetary cover and lubricate seal with US Lube or other approved SAE 80W90 oil.



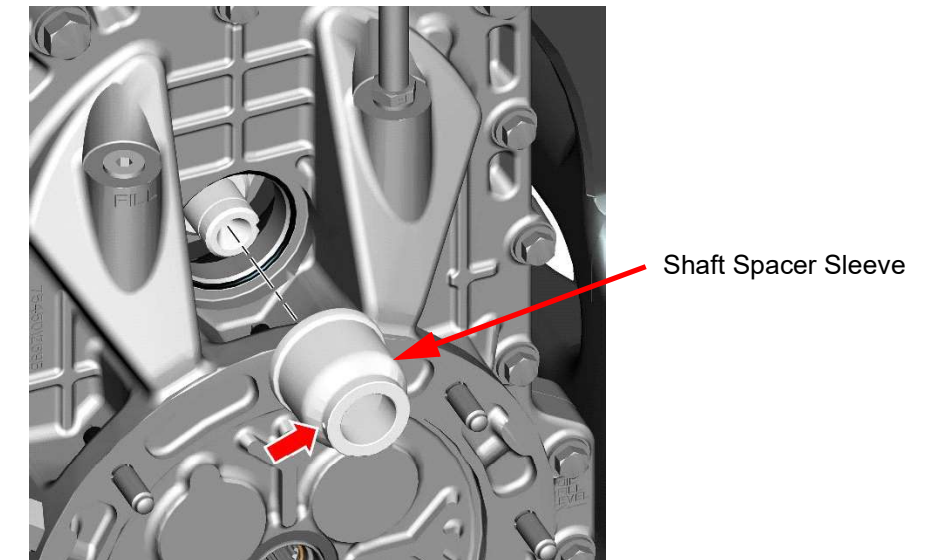
**Figure 11-162. Installing Planetary Cover Seal**

58. Apply Loctite 243 to the threads of the planetary cover bolts.
59. Verify the location of the fill hole on the planetary cover in relation to the planetary gear and align.
60. Using a 16mm socket, install new washer seals and the cover bolts securing the planetary cover. **Torque the bolts to 50 ft-lbs (68 Nm).**



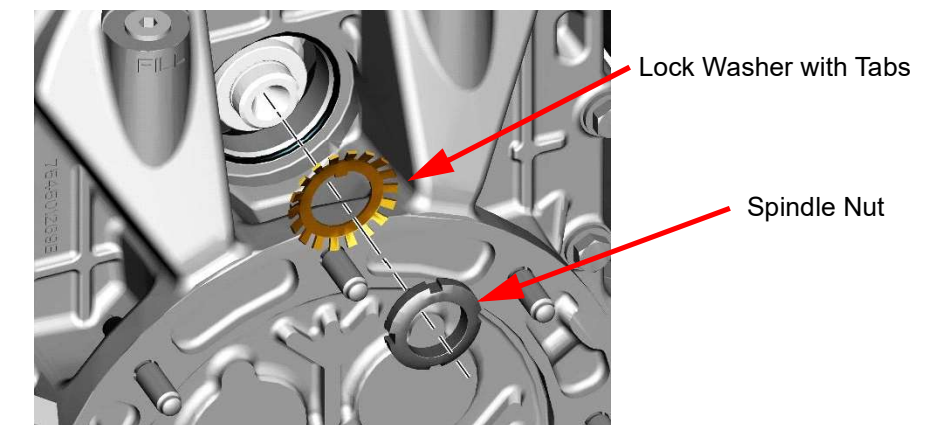
**Figure 11-163. Installing the Planetary Cover**

61. Install the shaft spacer sleeve.



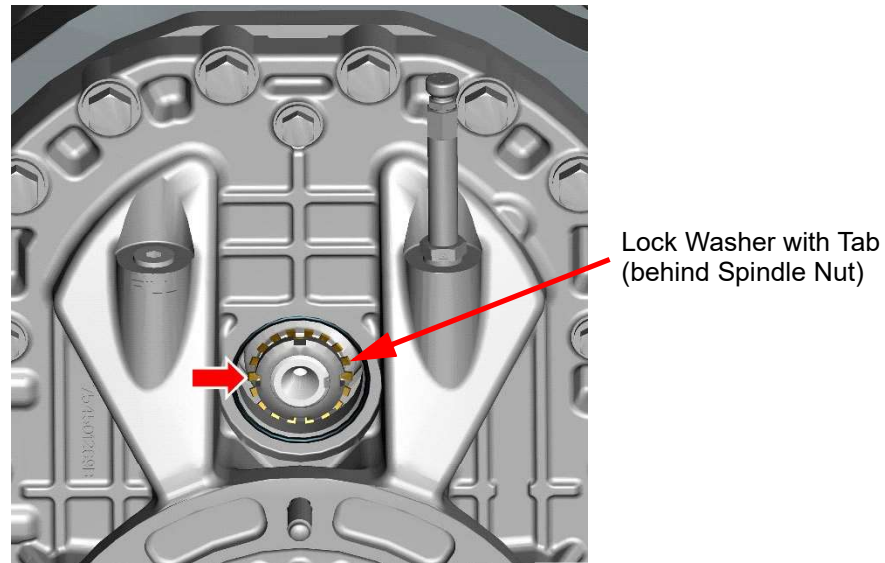
**Figure 11-164. Installing the Shaft Spacer Sleeve**

62. Install the lock washer and the nut. Using the spindle nut socket, **torque the nut to 33 ft-lbs (45 Nm).**  
**Note:** The lock nut should be installed with the chamfer side inboard.



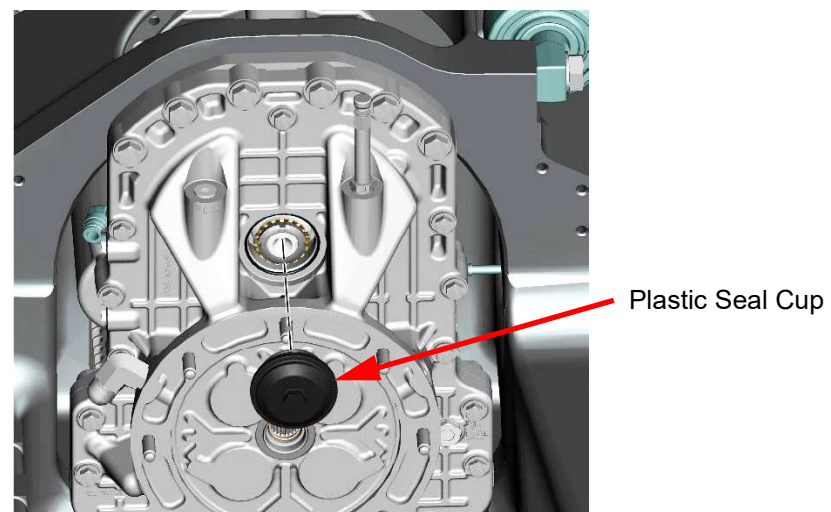
**Figure 11-165. Installing the Spindle Nut and Lock Washer**

63. Using a tab bending tool, bend over a lock washer tab.  
**Note:** It may be necessary to advance the nut to line up the tab on the lock washer.



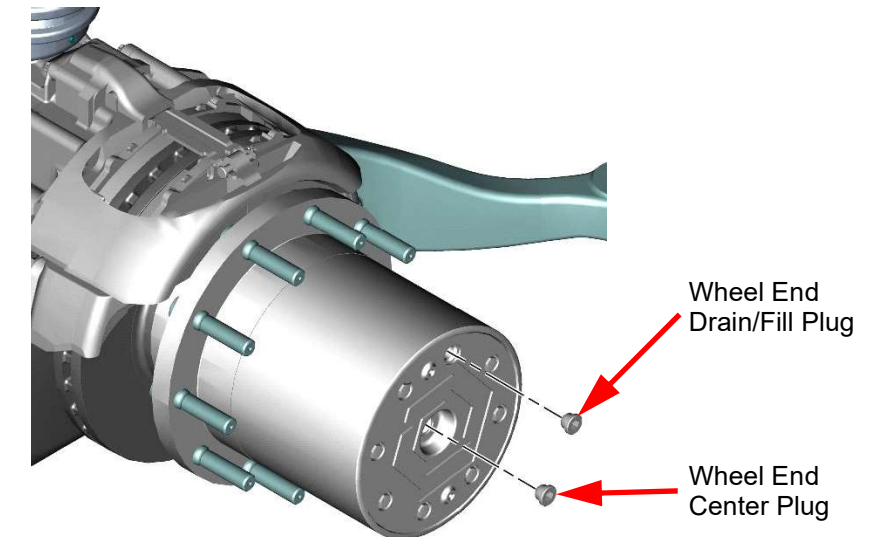
**Figure 11-166. Bending a Tab on the Spindle Nut Lock Washer**

64. Apply US Lube or approved SAE 80W90 oil to the O-ring seal on the seal cup.  
 65. Using a 16mm socket with a 6 inch extension, install the seal cup.  
**Torque to 13 ft-lbs (18 Nm).**  
**Note:** Do not use power tools to install the plastic seal cup.



**Figure 11-167. Installing the Gearbox Seal Cup**

66. Check and clean the drain/fill plug and center plug, then lube the O-rings on the plugs with the approved SAE 80W90 oil prior to reinstalling.  
 67. Rotate the wheel end until the outer drain/fill plug is at the 2 o'clock (vertically up and slightly to the side) position.



**Figure 11-168. Installing Wheel End Drain/Fill Plug and Center Plug**

68. Fill the wheel end with approved SAE 80W90 oil until the oil flows out of the center hole.  
 69. Using a 12mm Allen socket, install the center plug and drain/fill plug.  
**Torque to 22 ft-lbs (30 Nm).**  
 70. Install the wheels and tires on the side of the axle being serviced.  
 71. Referencing the Traction Motor Removal and Replacement procedure, install the Traction Motor in the DuoPower Axle.  
 72. Referencing the DuoPower Axle Removal and Replacement procedure, install the DuoPower Axle in the vehicle.  
 73. Lower the vehicle off the jack stands and chock the wheels.  
 74. Set the parking brake and then remove the wheel chocks.  
 75. Verify proper vehicle operation and complete service documentation, as required.

## Rear Air Suspension

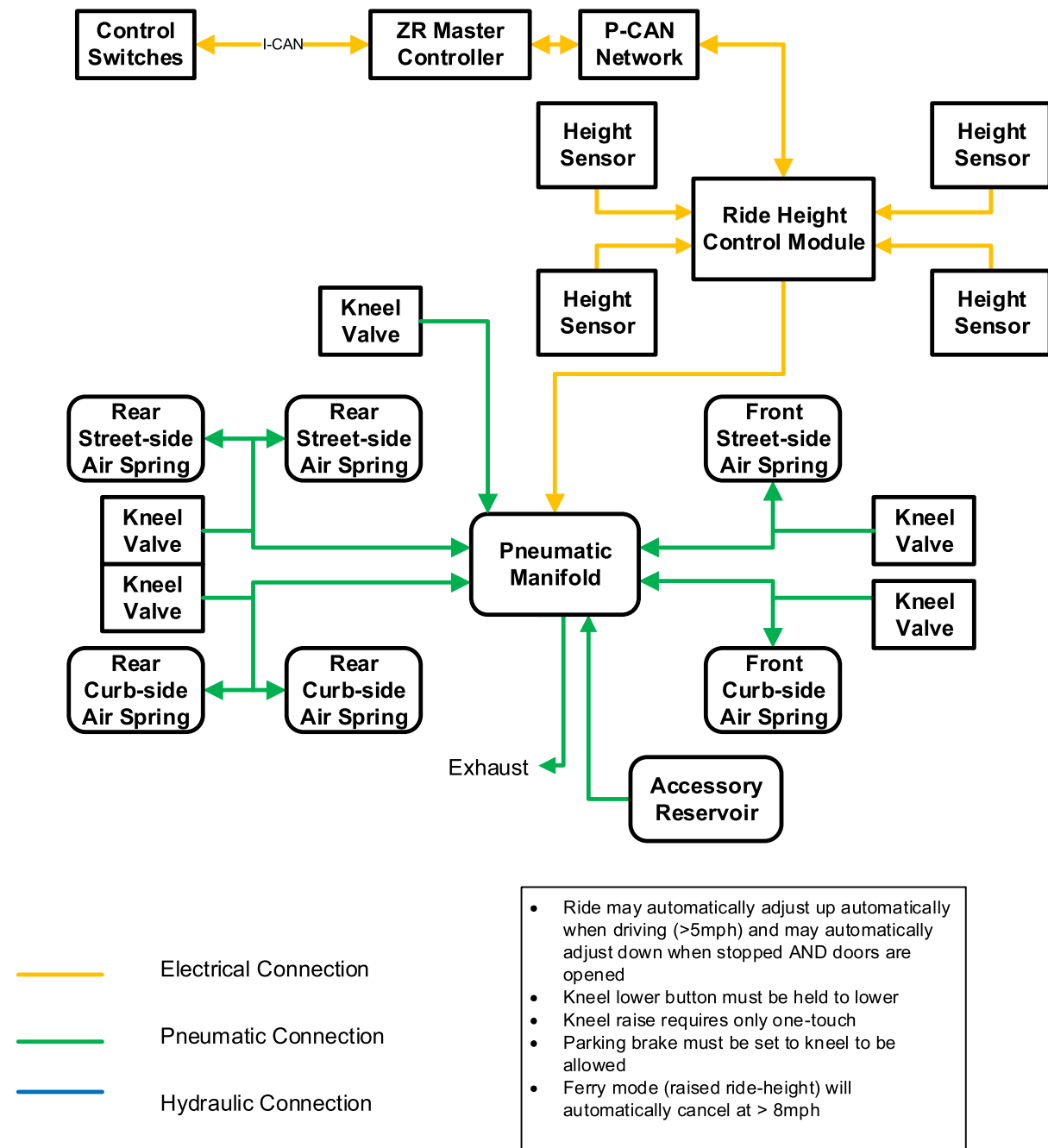


Figure 11-169. Air Suspension System Diagram

## Rear Suspension, Technical Specifications

Table 11-5: Rear Shock Absorber Technical Specifications

Parameter	Specification
Compressed Length	293mm +/-3 (11.54" +/- .118)
Extended Length	478mm +/-3 (18.8" +/- .118)
Hydraulic Stop Starts	470mm (18.5")
Level Position in Vehicle	391mm (15.4")
Max. Installation Tightening Torque	70 Nm (51.6 lb-ft)

Table 11-6: Rear Air Spring Technical Specifications

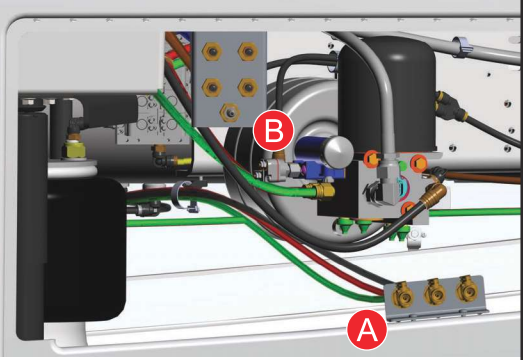
Parameter	Specification
Bellows #	1T19L-5
Assembly Weight	25 lbs
Design Height	9 to 11 inches
Minimum Jounce Height	5.75 inches
Loading Capacity at 20 psig	2,080 lbsf
Loading Capacity at 60 psig	6,240 lbsf
Loading Capacity at 90 psig	9,360 lbsf
Maximum Diameter	13.5 inches
Material Type	Natural Rubber
Operating Temperature	135°F to -65°F

## Rear Air Bag Removal and Replacement

---

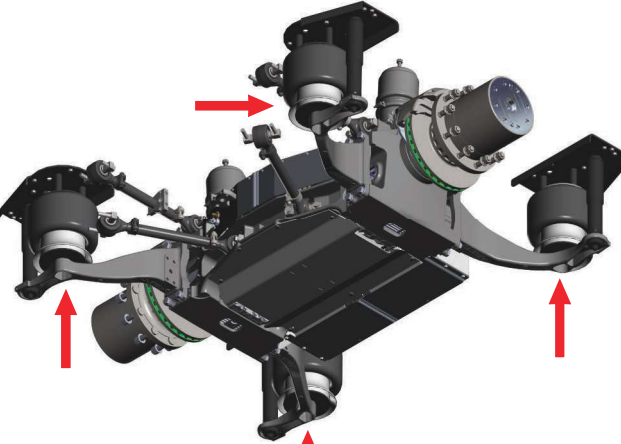
To remove an air bag from the DuoPower Axle, the following tools are recommended:

- 3/4" Socket/Ratchet
- 1-1/16" Socket/Ratchet
- 3/4" Wrench
- Torque Wrench (rated from 40 ft-lb to 90 ft-lb)



**Step 1**

- Power down the bus.
- Perform lock-out/tag-out.
- Lift the bus to take weight off the suspension.
- Drain system air lines. (A)
- Drain individual air bag. (B)



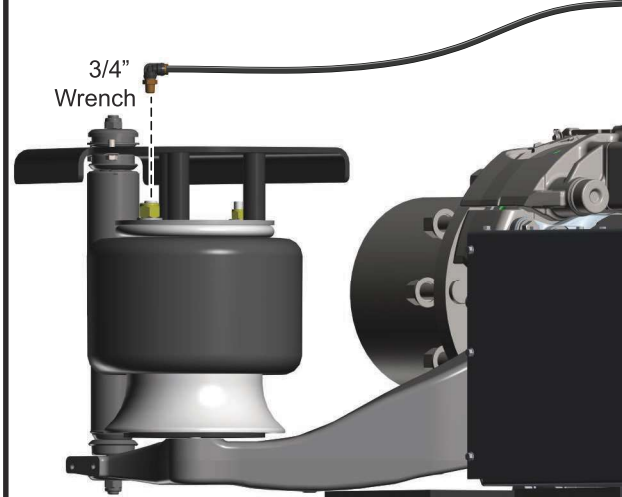
**Step 2**

- Remove the wheels and tires from the side where the air bag is to be changed.

NOTE: Each of the rear air bags can be removed individually using the following instructions.

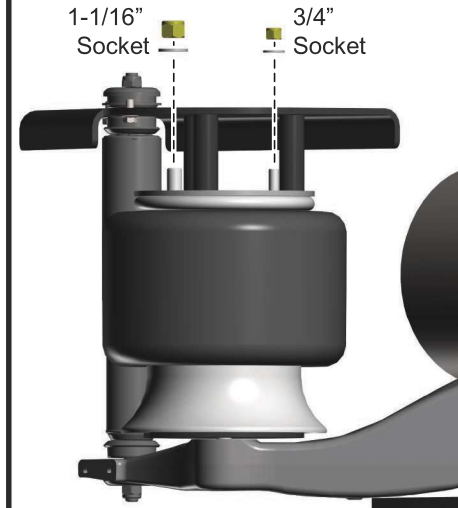
**Step 3**

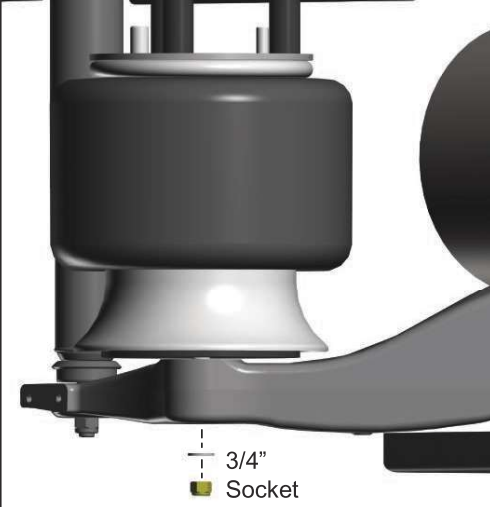
- Support the DuoPower drive with an approved lifting device.
- Remove the air hose by disconnecting the push-to-connect fitting.



**Step 4**

- Remove the two nuts and washers that secure the air bag to the mounting bracket.



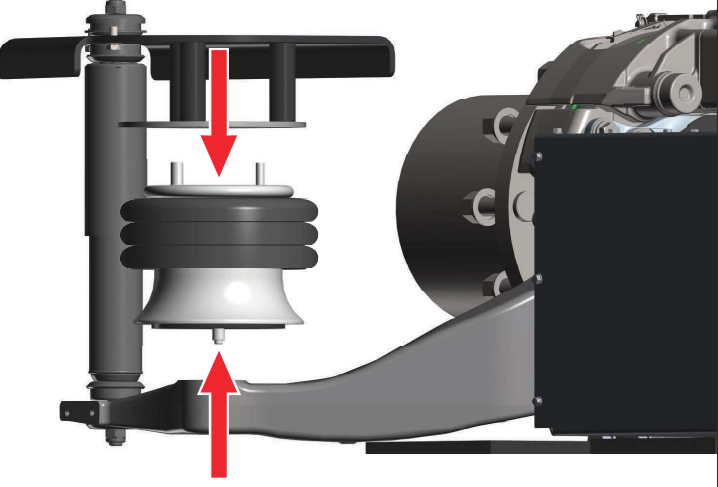


**Step 5**

- Remove the nut and washer that secure the air bag to the rear suspension.

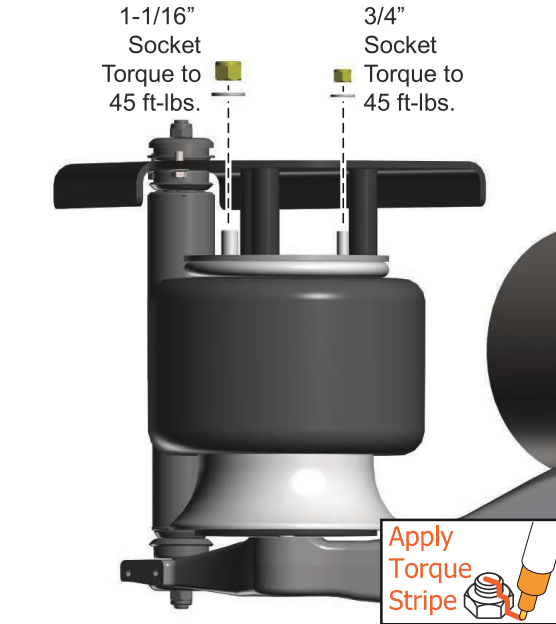
**Step 6**

- Compress the air bag to remove.
- Compress the replacement air bag to install.



**Step 7**

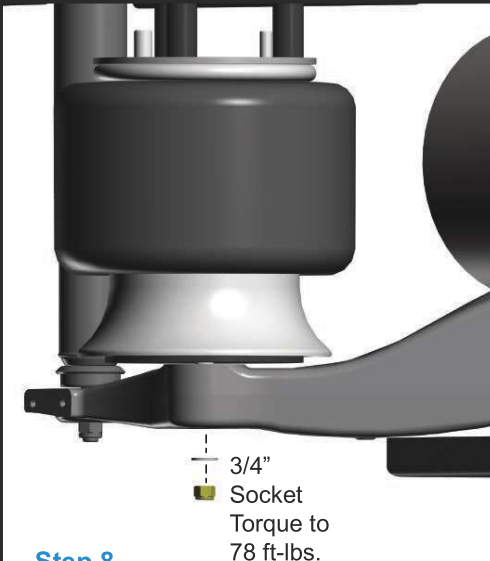
- Replace the two nuts and washers to secure the new air bag to the bracket.



1-1/16" Socket Torque to 45 ft-lbs.

3/4" Socket Torque to 45 ft-lbs.

Apply Torque Stripe

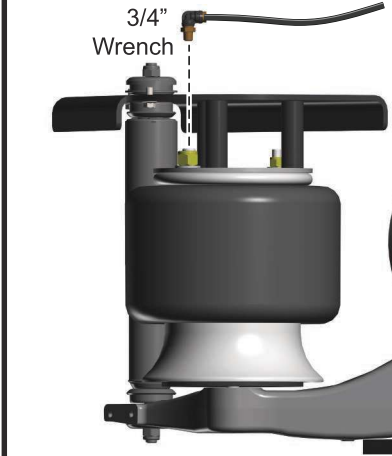


**Step 8**

- Replace the nut and washer that secures the new air bag to the rear suspension.

3/4" Socket Torque to 78 ft-lbs.

Apply Torque Stripe



**Step 9**

- Replace the air hose by connecting the push-to-connect fitting.

**Step 10**

- Replace the wheels.
- Ensure that all the drain lines are closed.
- Remove the lifting device and lower the bus.
- Restore power to the bus.

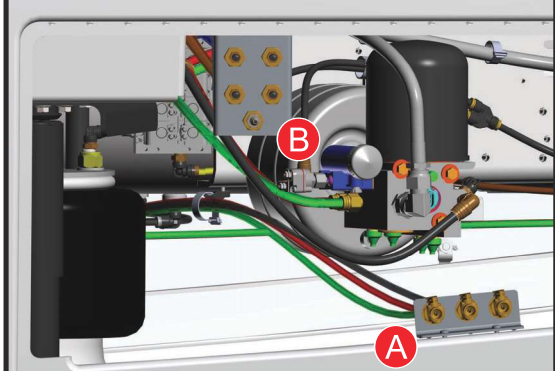


Figure 11-170. Rear Air Bag Removal and Replacement

This page intentionally left blank