



# TECHNICAL SERVICE BULLETIN

<b>Subject</b>	DuoPower Axle Shaft Failure Replacement
<b>Issue Date</b>	11/3/2022
<b>Revision Date</b>	3/5/2024
<b>Service Bulletin Number</b>	SC-22-140
<b>Models Affected</b>	Service Specified Vehicles
<b>Complete By</b>	Next Service Opportunity
<b>Labor Operation Code</b>	PP51Z
<b>Description</b>	This procedure describes the process of replacing the axle shaft on DuoPower axles.

Labor Table				
	Operation	Technicians	Hours	Labor Time (T x H)
1	Steps 1-41	2	4	8 Hours
		<b>Total Labor Time:</b>		8 Hours

Contact the Field Service Team with any questions related to the following procedure.



**Parts Required:**

063141	Service Retrofit Kit, Axle Shaft Replacement, DuoPower		Qty.	UOM
	050316	Description of part	1	EA
	050312	O RING, 254 X 4, WHEEL END, AXLE	2	EA
	050313	DRAIN/FILL PLUG, WHEEL END, AXLE	7	EA
	050314	COVER BOLTS, WHEEL END, AXLE	7	EA
	050390	SEAL WASHER, WHEEL END, AXLE	1	EA
	125-6417	WASHER, LOCK	2	EA
	050321	SHAFT NUT, WHEEL END, AXLE	1	EA
	050317	SNAP RING, COVER, WHEEL END, AXLE	1	EA
	050309	WHEEL END COVER, WHEEL END, AXLE	1	EA
	050393	NEEDLE ROLLER BEARING PLANETARY GEAR, AXLE	1	EA
	050311	SHAFT RETAIN-WASHER, WHEEL END, AXLE	1	EA
	133-4700	LOCTITE (CCS) 680	1	EA
	052819	CAP, GEARBOX, DUOPOWER	1	EA

**Tools Required:**

- 
- Approved Wheel Lifts (4 Required)
  - Ratchet
  - 10mm Socket
  - 13mm Socket
  - TMFS 5 Socket, Shortened (PN: 063077)
  - Wheel-end Tool (PN: 120-5847)
  - Dog Bone Tool
  - Pick
  - Brass Mallet
  - Small Hammer
  - Calibrated Torque Wrench
  - Torque Stripe Pen
  - Loctite 243
  - Jack Stands (4 Required)
  - 1/2-Inch Drive Pull Handle
  - 12mm Socket
  - 16mm Socket
  - TMFS 7 Lock Nut Socket (PN: 120-7747)
  - Approved Lifting Device for Axle
  - Snap Ring Pliers
  - Heat Gun
  - Pry-Bar
  - Flashlight
  - Offset Adapter for Torque Wrench (PN: 128-2242)
  - SAE 80W90 Oil (Or Approved)
  - Never Seize



---

## Overview:

This is a summary of what will be covered in the procedure.

---

## Step 1:

This procedure requires the removal and replacement of the DuoPower Axle from the bus. The Axle removal and replacement procedures are included in the Maintenance Manual applicable to the bus that you are working on. Prior to beginning the procedure, familiarize yourself with the removal and replacement procedure for the Axle in the Maintenance Manual as well as the procedure in this document. The latest version of the Maintenance Manual should be downloaded from the following location before beginning the procedure.

---

## Step 2:

Complete the Proterra approved Lockout/Tagout procedure to make the bus safe for work. Lift the bus using Wheel Lifts and support it with Jack Stands to access the DuoPower Drive. Refer to the Maintenance Manual for lifting the bus and the removal and reinstallation of the DuoPower Drive.

---

## Step 3:

Using a 10mm Ratchet/Socket, remove the top covers from the DuoPower Axle.

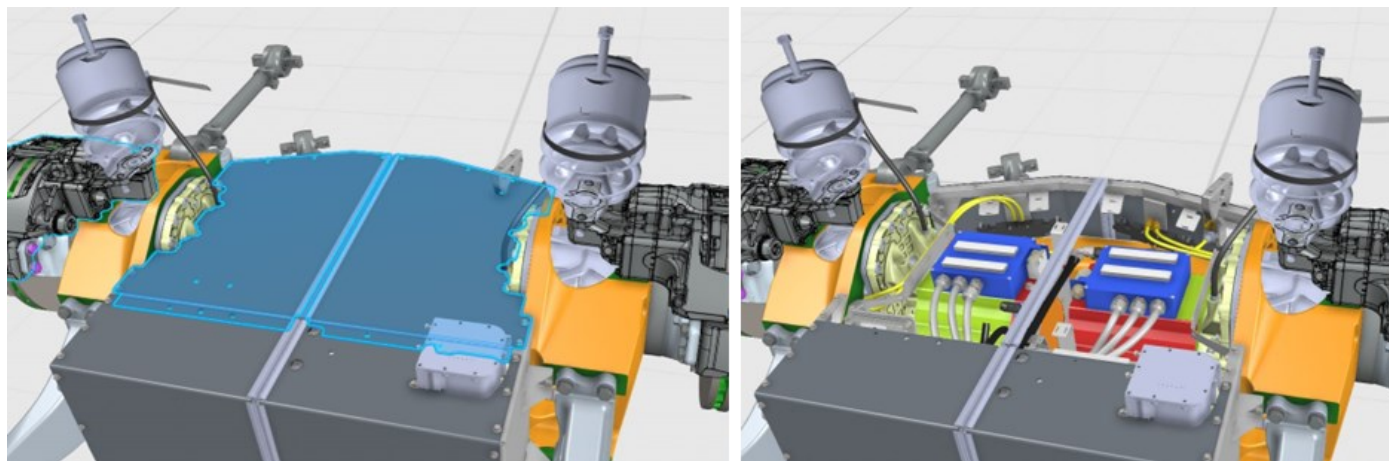

---

**Step 4:**

Using a 13mm Ratchet/Socket, remove the bolts that secure the Harness Brackets (046740) to the DuoPower Drive.

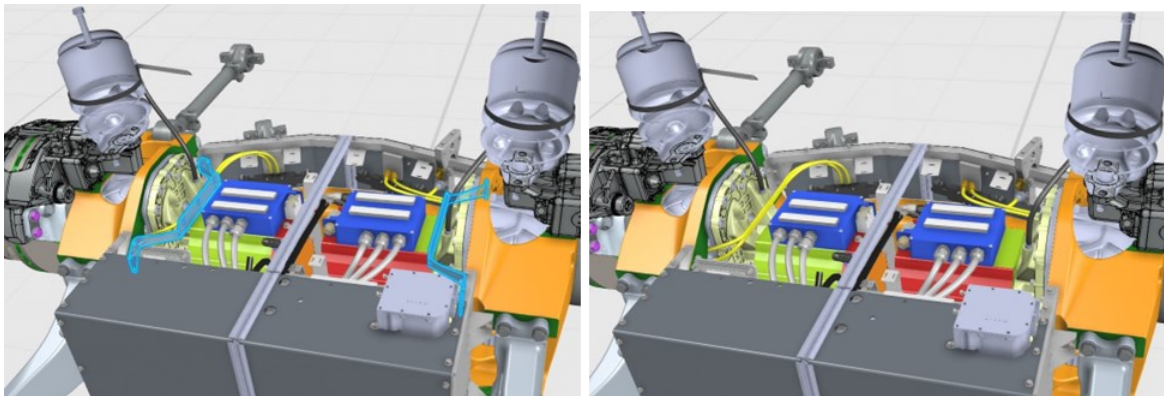

---

**Step 5:**

Carefully remove the Harness Brackets (046740) from the Gearboxes.

Access one of the Gearboxes through the area where the Harness Brackets (046740) were removed. Cut any Cable Ties (001912) necessary to access the gearbox.

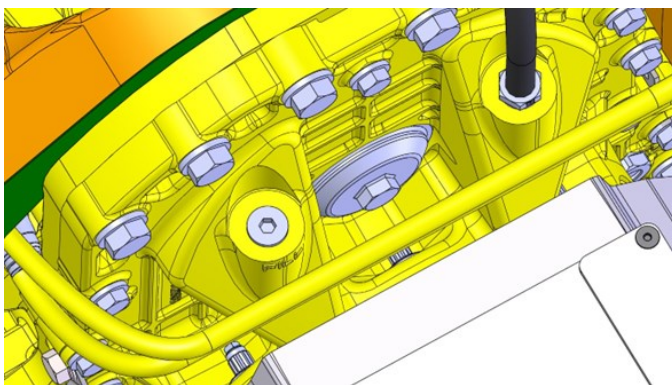

---

**Step 6:**

Rotate the Wheel End until the outer Drain/Fill Plug is at the six o'clock position.

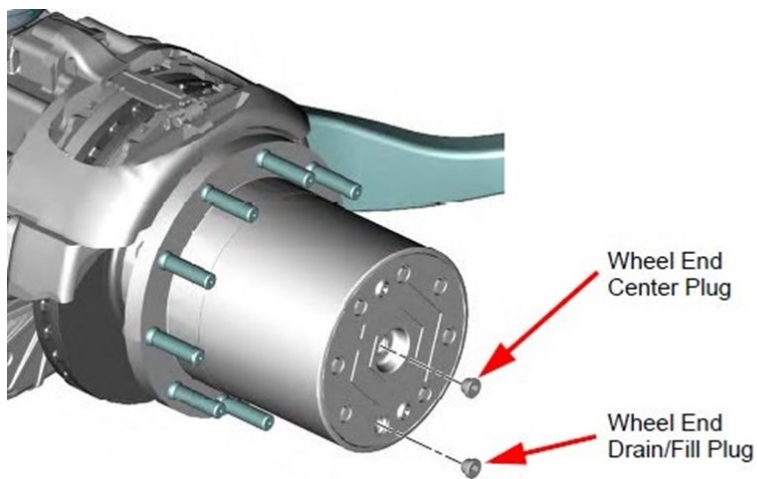

---

**Step 7:**

Place a Catch Pan capable of holding three quarts of fluid below the hub.

Using a 12mm Ratchet/Socket, remove the Drain/Fill Plug and Center Plug to allow the Wheel End to drain into the Catch Pan.

---

**Step 8:**

Using a 16mm Ratchet/Socket, remove the Bolts, Washer Seals, and Planetary Cover. Discard the Washer Seals.

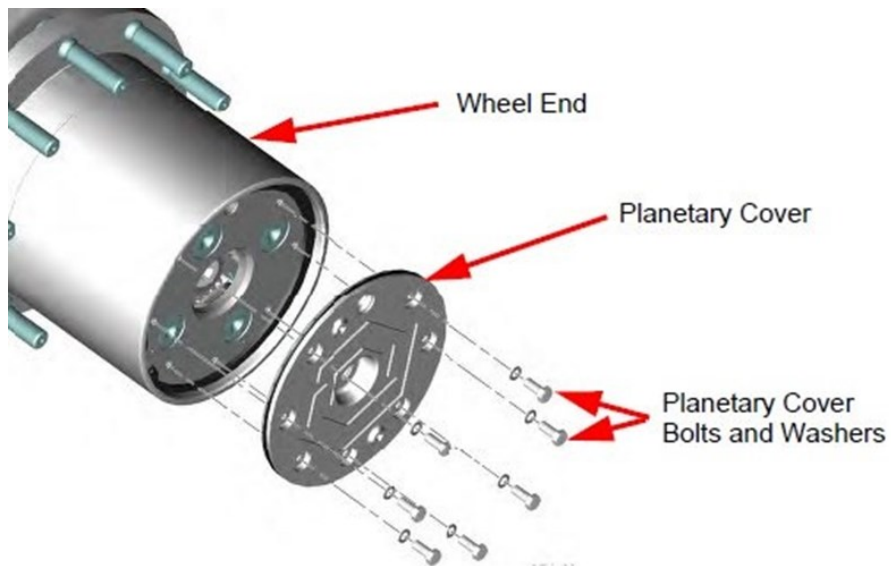

---

**Step 9:**

Remove and discard the Planetary Cover and O-ring Seal.

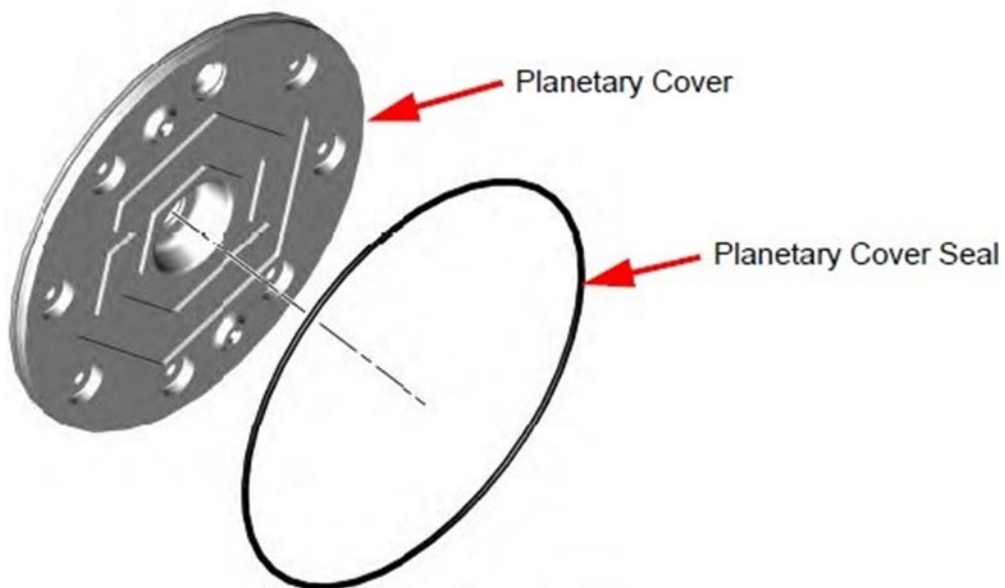

---

**Step 10:**

Using a 16mm Ratchet/Socket, remove and discard the Seal Cup. NOTE: Do not use power tools to remove the plastic Seal Cup.

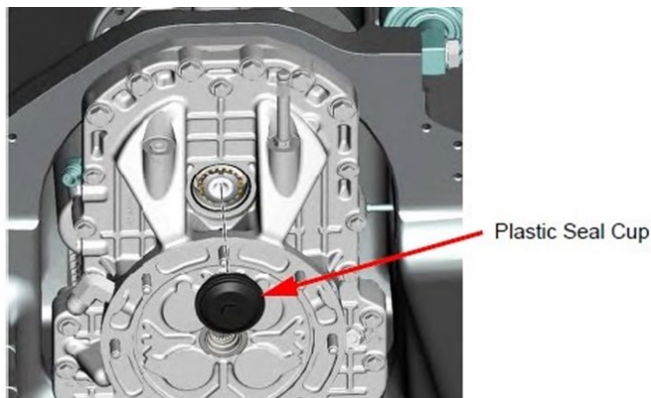

---

**Step 11:**

Using a Pick or Flat Blade Screwdriver, straighten the tab shown on the Lock Washer in the following illustration.

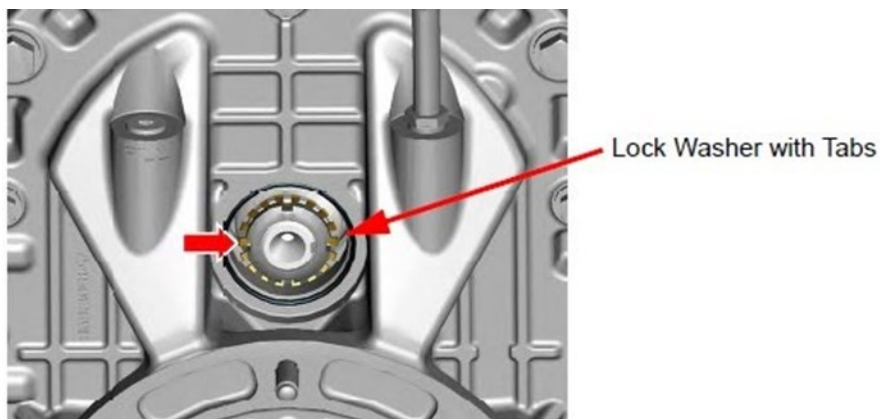

---

**Step 12:**

Using a 1/2-Inch Pull Handle with a TMS #5 Spindle Nut Socket, remove the Nut and Lock Washer. Discard the Lock Washer.

NOTE: An assistant may be required to position a Pry-Bar or similar tool between the wheel studs to prevent the wheel end from rotating during the torquing process.

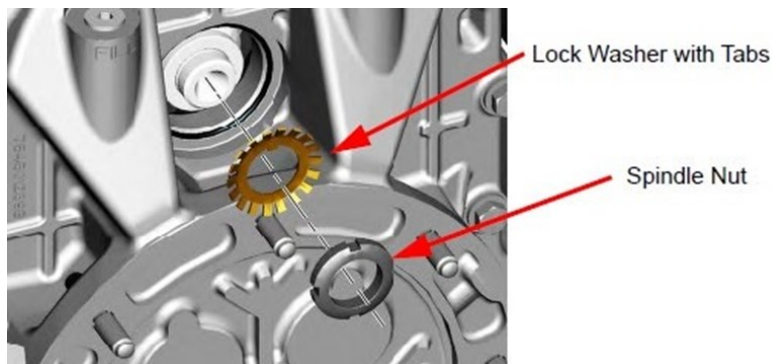

---

**Step 13:**

Locate the small hole in the Shaft Spacer Sleeve shown below. Using a Pick placed in the hole, remove the Shaft Spacer Sleeve.

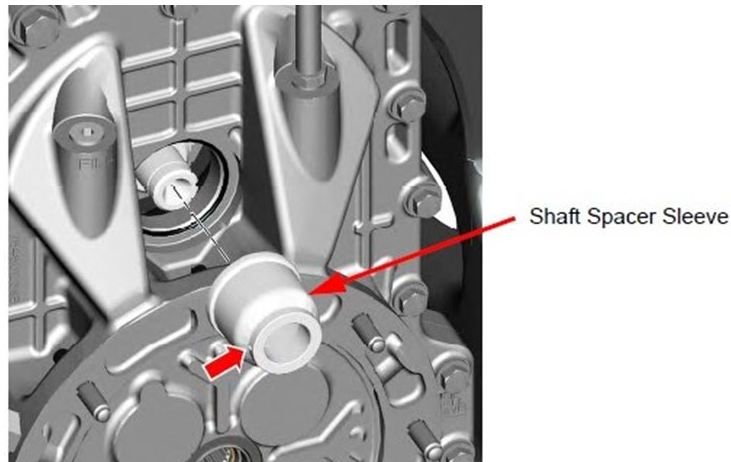

---

**Step 14:**

Using Snap Ring Pliers, remove the Snap Ring and Planetary Gear assembly.

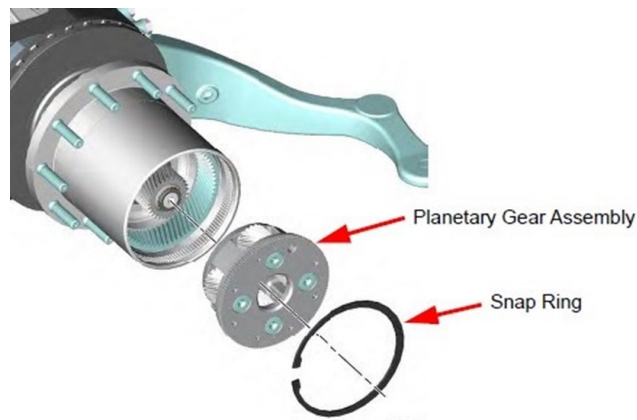

---

**Step 15:**

Remove the defective Axle Shaft Assembly.

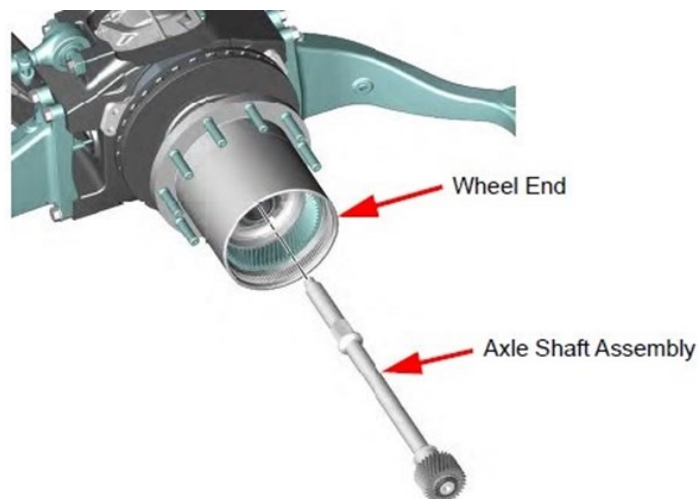

---

**Step 16:**

Remove the Sun Gear and Retention Washer from the Shaft.



---

**Step 17:**

Using a Heat Gun set to 1000° Fahrenheit, apply heat to the inner race of the Shaft Bearing (050393) until it can slide onto the Axle Shaft (050390).

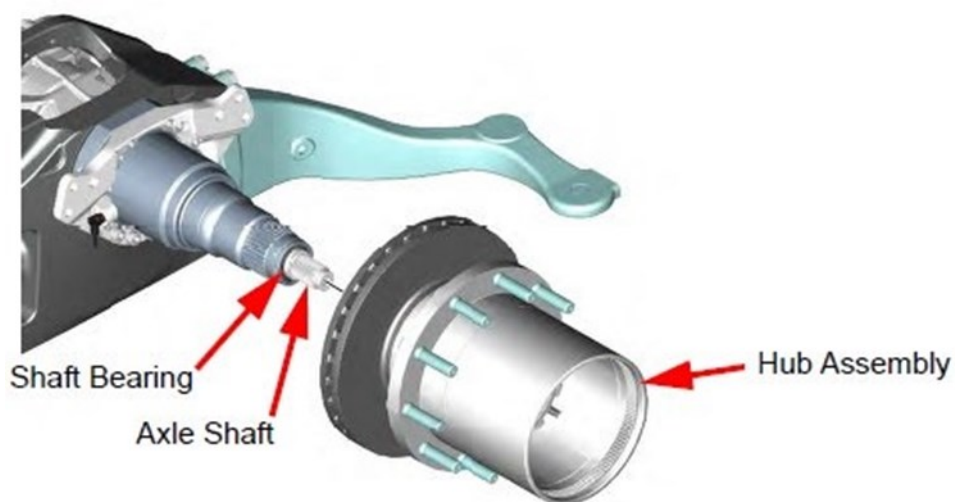

---

**Step 18:**

Install the new Axle Shaft (050390) into the Wheel End assembly.

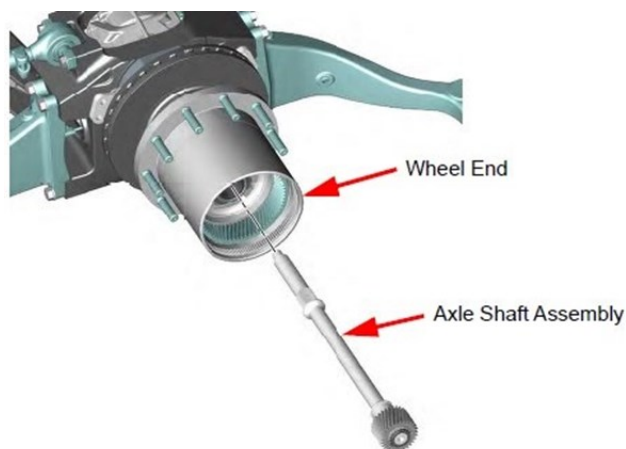

---

**Step 19:**

Install the Sun Gear and Retention Washer onto the axle shaft.

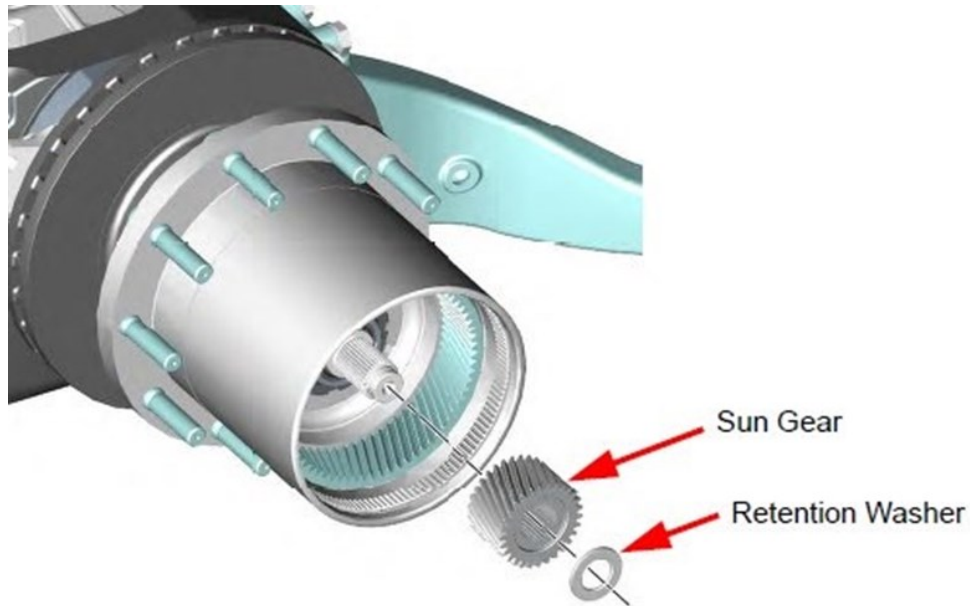

---

**Step 20:**

Install a new Lock Washer ( 125-6417 ) and the Lock Nut (050321) onto the Axle Shaft and tighten it. Torquing is not required at this time.

**NOTE:** The Lock Nut should be installed with the chamfer side inward.

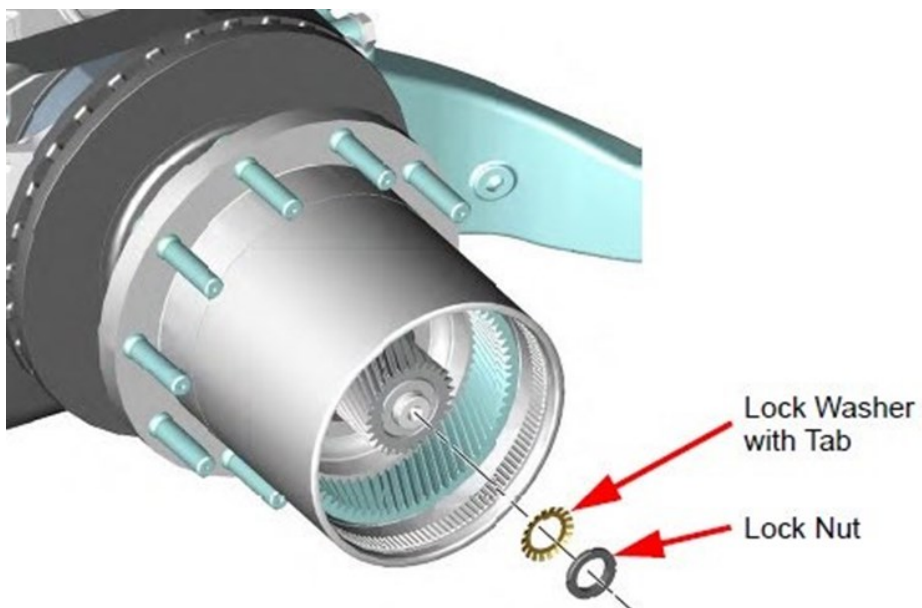

---

**Step 21:**

If a Tab does not align, continue to torque the Lock Nut until a Tab aligns with a Lock Nut slot.

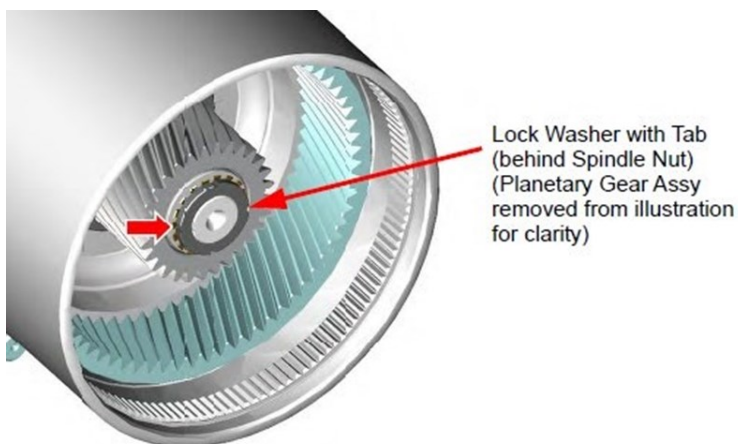

---

**Step 22:**

Using a Flat Blade Screwdriver or a Pick, bend over a Lock Washer Tab into a slot.

Using Orange Torque Stripe Paint, mark the Lock Washer and Lock Nut.

---

**Step 23:**

Using Snap Ring Pliers, install the Planetary Gear assembly and Snap Ring (050317). A soft headed hammer or rubber mallet may be needed to seat the Planetary Gear assembly.

**NOTE:** Before proceeding to the next step, confirm that the Snap Ring is properly seated.

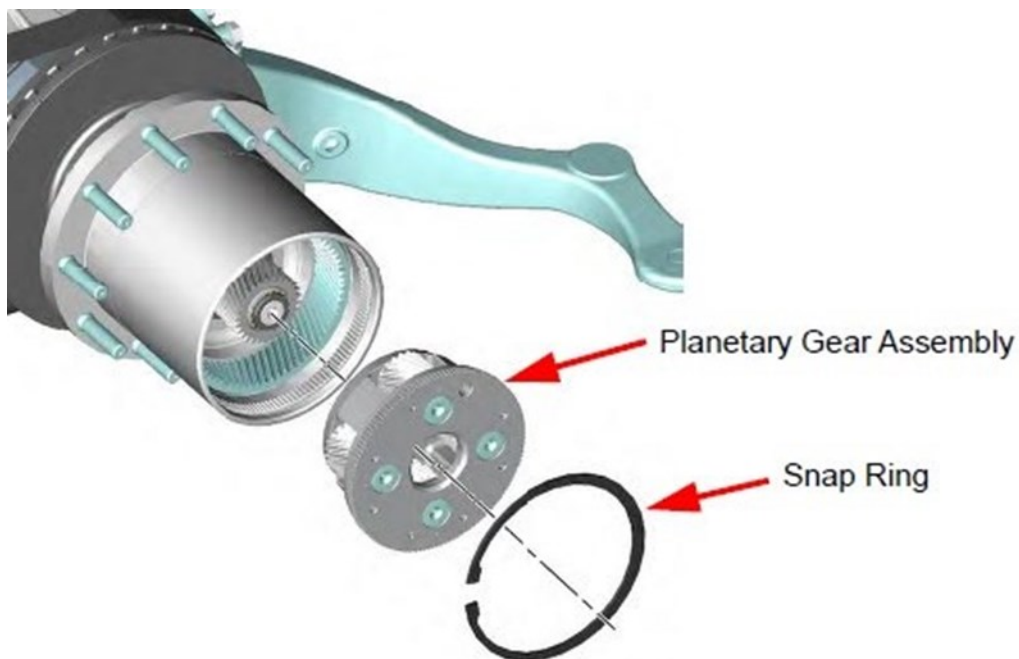

---

**Step 24:**

Using a Calibrated Torque Wrench with a TMFS #7 Lock Nut Socket (120-7747), torque the Lock Nut to 45 foot-pounds.

**NOTE:** Position a Pry-Bar or similar tool between the wheel studs to prevent the wheel end from rotating during the torquing process.

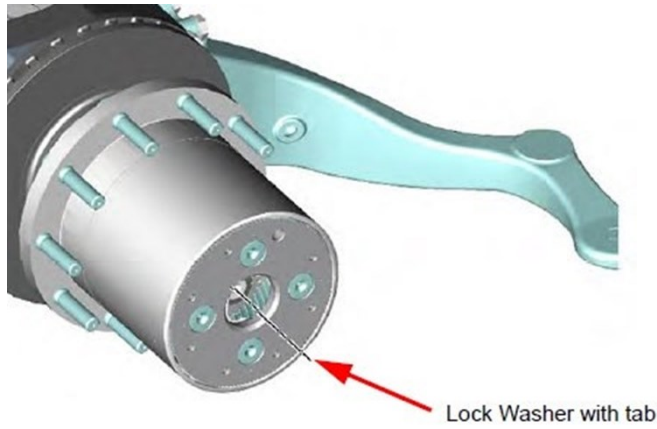

---

**Step 25:**

If a Tab does not align, continue to torque the Lock Nut until a Tab aligns with a Lock Nut slot.

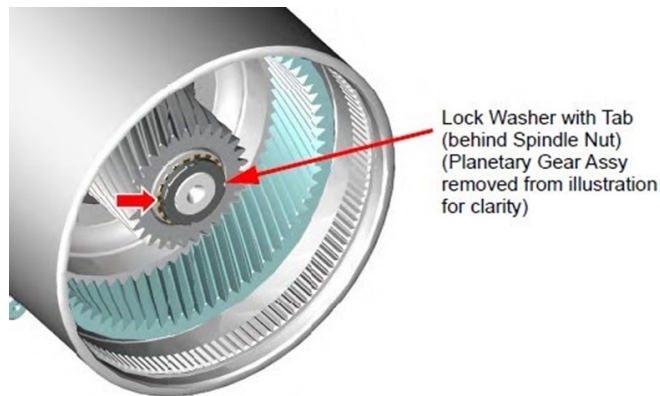

---

**Step 26:**

Install a New O-ring Seal (050316) on the Planetary Cover (050309) and lubricate the Seal (050316) with US Lube or other approved SAE 80W90 oil.

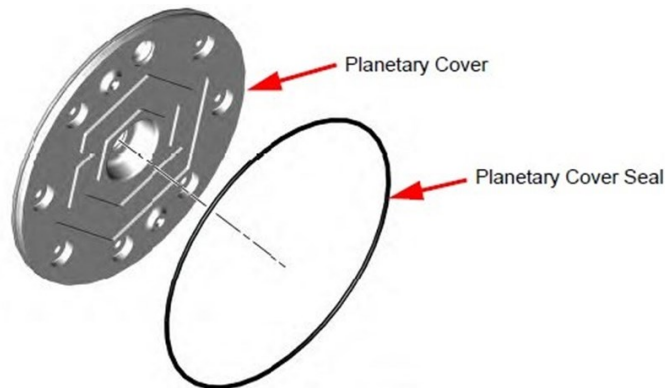

---

**Step 27:**

Apply a small amount of Loctite 243 to the threads of the Planetary Cover Bolts (050313).

Verify the location of the fill hole on the Planetary Cover in relation to the Planetary Gear and align them.

Using a 16mm Ratchet/Socket, install new Washer Seals (050314) and the Cover Bolts (050313) securing the Planetary Cover (050309).

Using a Calibrated Torque Wrench with a 16mm Socket, torque the Bolts to 50 foot pounds.

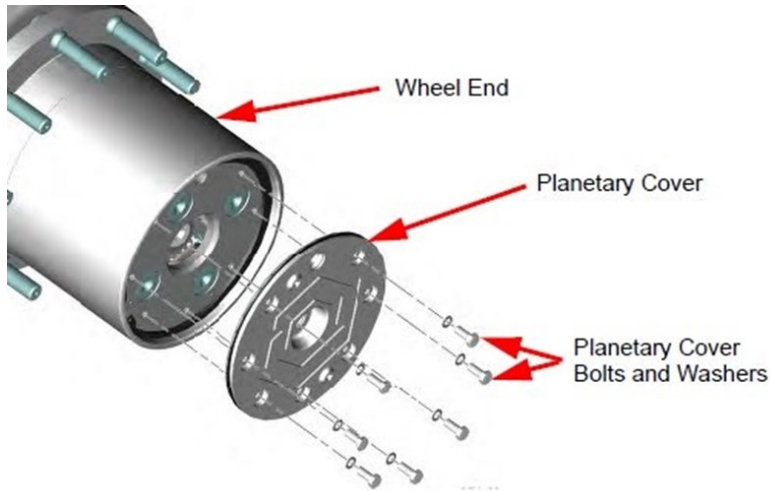

---

**Step 28:**

Inspect and clean the Drain/Fill Plug (050312) and Center Plug (050312). Lube the O-rings on the plugs with approved SAE 80W90 oil prior to reinstalling the plugs.

Rotate the Wheel End until the Drain/Fill Plug is at the 2 o'clock position.

Fill the Wheel End with approved SAE 80W90 oil until the oil flows out of the center hole.

Using a 12mm Allen Socket, install the Center Plug and the Drain/Fill plug. Using a Calibrated Torque Wrench with a 12mm Allen Socket, torque the Plugs to 22 footpounds.

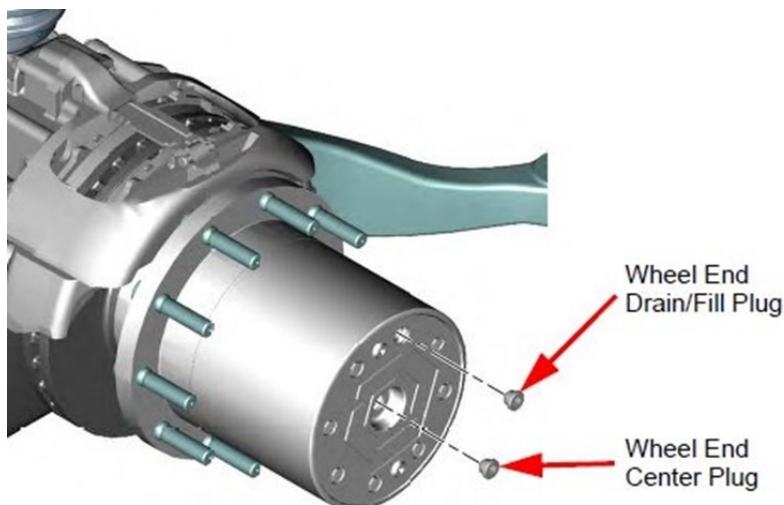

---

**Step 29:**

Move to the gearbox end of the axle shaft.

Slide the bushing (shaft spacer) into the gearbox assembly over the axle shaft.

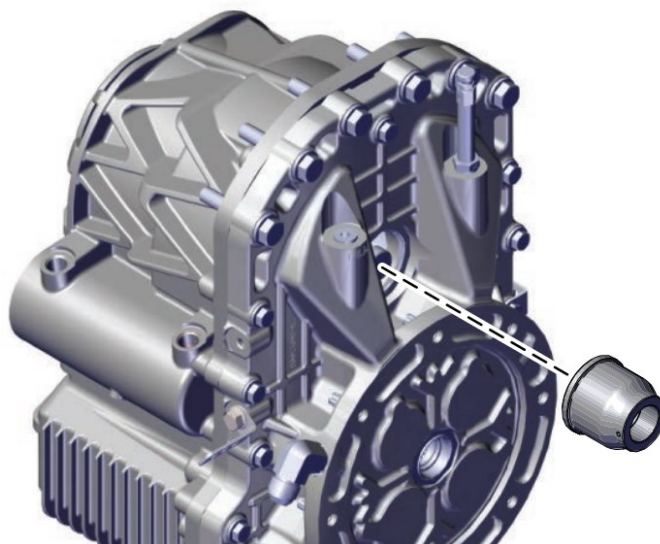

---

**Step 30:**

Use the SKF TMFS 5 to hand tighten the special nut. This will fully seat the shaft spacer sleeve. **Do not install the lock washer at this time.**

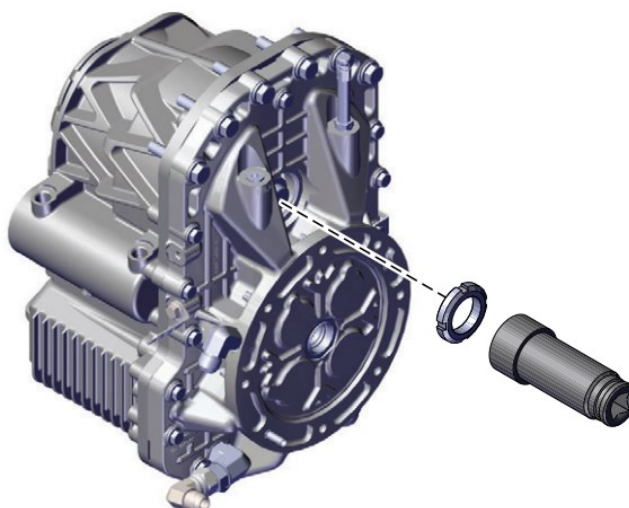

---

**Step 31:**

Use the SKF TMFS 5 to remove the special nut.

---

**Step 32:**

The following photographs show the difference between the old style of Lock Washer and the new L-Tab Lock Washer (125-6417).

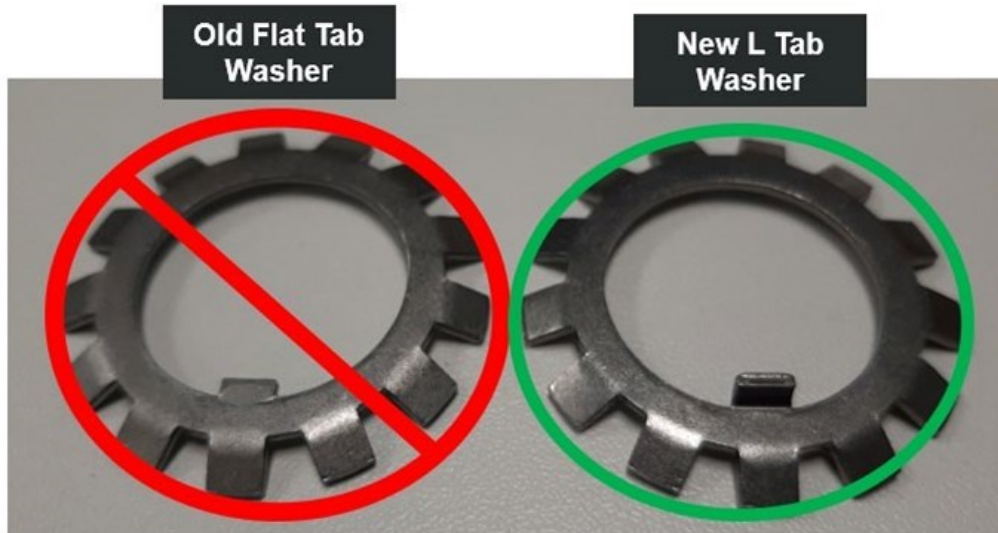

---

**Step 33:**

Place the Lock Washer (125-6417) into position with the L-Tab facing outward toward the Wheel Ends (facing away from you). The Outer Diameter Tabs will be facing inward toward the nut (facing you).

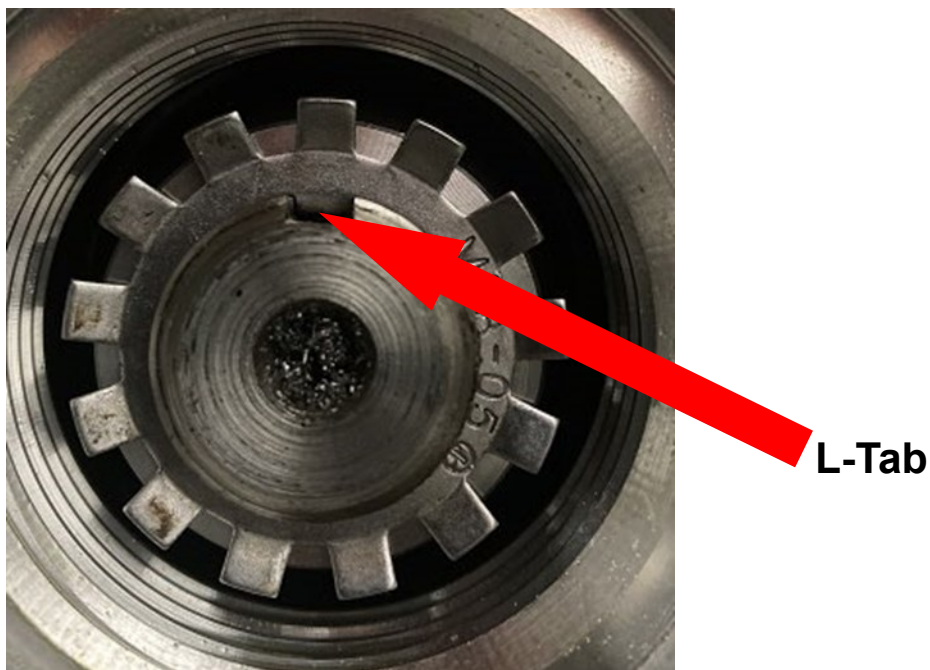

---

**Step 34:**

After torquing the Lock Nut, observe the Lock Washer (125-6417) to determine if one of the Outside Diameter Tabs aligns with one of the four slots in the Lock Nut.

If none of the Outside Diameter Tabs align with a Lock Nut Slot, continue using the Torque Wrench to tighten the Lock Nut until a Tab is in alignment. Do not exceed 50 foot pounds of Torque.

Using a Flashlight, inspect the Lock Washer (125-6417) for damage. If the Lock Washer is damaged, it must be replaced with one of the spares from the kit.

---

**Step 35:**

Using a Flat Blade Screwdriver or a Pick, bend the Outside Diameter Tab into the slot on the Lock Nut.

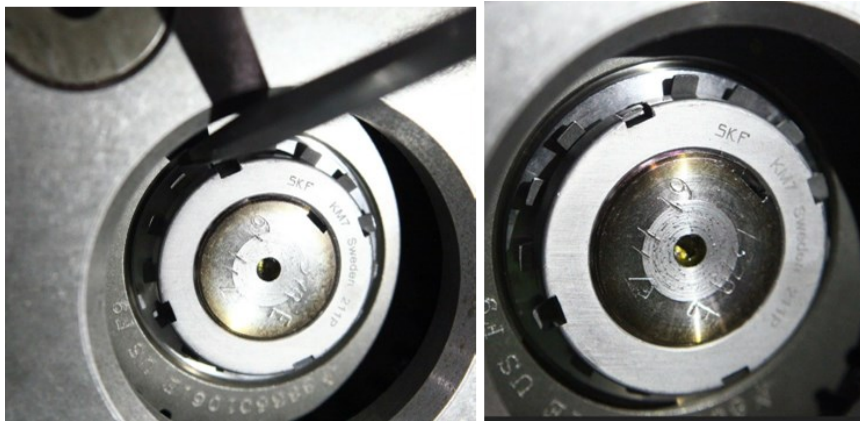

---

**Step 36:**

Using an Orange Paint Pen, mark the bent Tab.

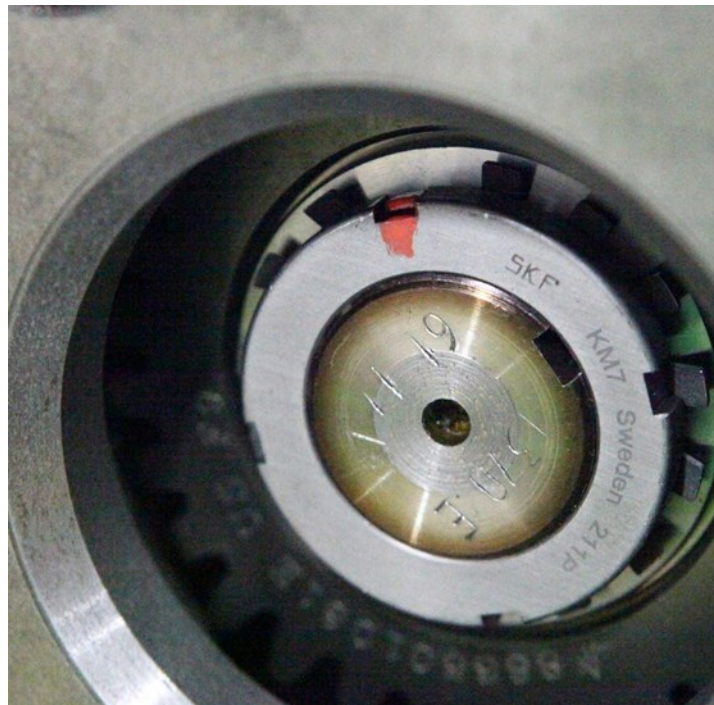

---

**Step 37:**

Using a Ratchet with a 6-Point 16mm Socket, replace the black dust (052819) cover shown in the following photograph.

Using a Calibrated Torque Wrench with a 6-Point 16mm Socket, torque the Dust Cover to 12 foot pounds.

Mark the Dust Cover with the Orange Paint Pen.

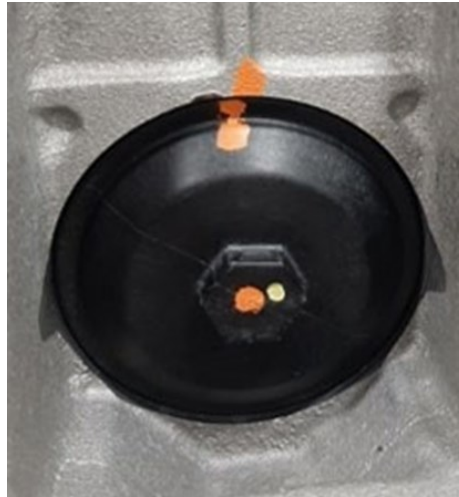

---

**Step 38:**

Carefully replace the Harness Brackets (046740) back onto the Gearboxes.

Using a 13mm Ratchet/Socket, replace the bolts that secure the Harness Brackets (046740) to the DuoPower Drive.

Using a Calibrated Torque Wrench with a 13mm Socket, torque the bolts to 27 footpounds.

Using an Orange Paint Pen, mark the properly torqued bolts.

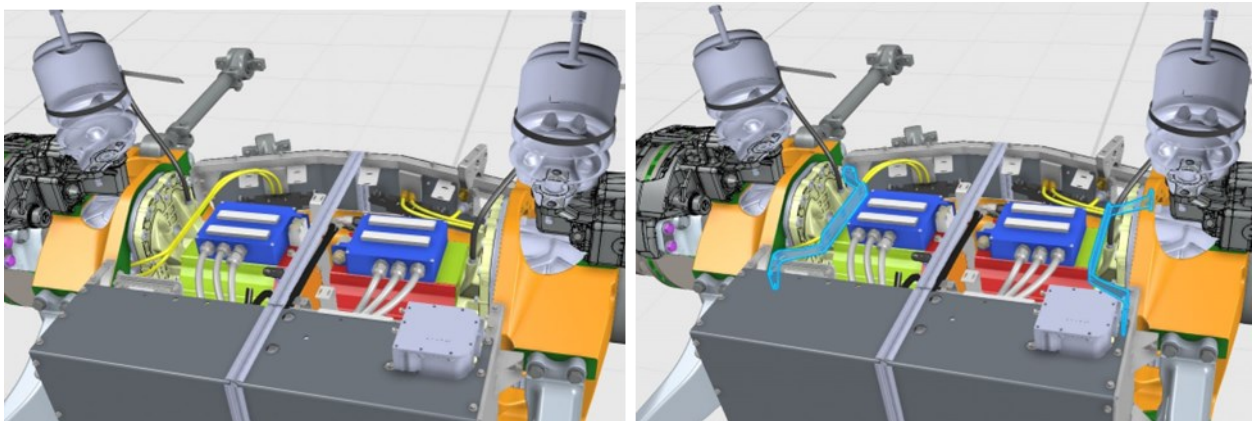

---

**Step 39:**

Using a 10mm Ratchet/Socket, replace the top covers on the DuoPower Axle using the original hardware.

Using a Calibrated Torque Wrench with a 10mm Socket, torque the bolts to 11 footpounds.

Using an Orange Paint Pen, mark the properly torqued fasteners.

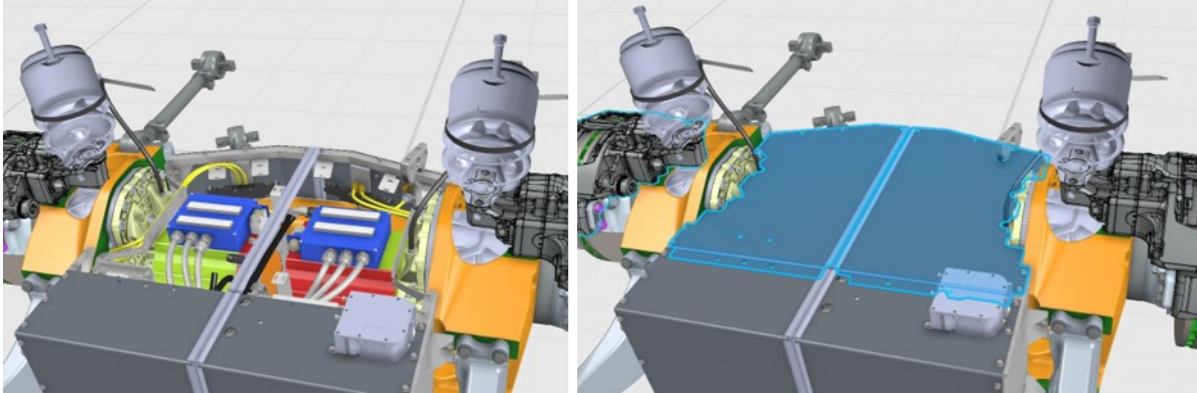

---

**Step 40:**

Record the Axle Serial Number on the Work Order. Also indicate whether the axle was on the curbside or streetside of the bus and if the other axle had the “11 19” markings.

Using 300 Grit Sandpaper and/or a Wire Brush, remove any surface rust from the Wheel Ends.

Using Alcohol and Shop Towels, remove any oil and debris from the Wheel Ends.

Using Flat Black Paint, paint the Wheel Ends.

---

**Step 41:**

Refer to the Maintenance Manual for replacing the DuoPower Drive and lowering of the bus.

Remove the Lockout/Tagout Devices and return the bus to service.