

Field campaign

Topic	Black 'S' Front door badge missing from Black Edition specification vehicles (SC24/30)
Market area	Germany E02 Bentley rest Europe (6E02),United Arab Emirates E06 Bentley Middle East and Africa (6E06),United Kingdom E01 Bentley UK (6E01),United States E05 Bentley USA and rest America (6E05)
Brand	Bentley
Transaction No.	2075748/1
Campaign number	ED23
Note	
Type	
US code	

Vehicle data

Bentayga Series - Black Edition

Sales types

Type	MY	Brand	Designation	Engine code	Gearbox code	Final drive code
4V1*	2024	E		*	*	*
ZV1*	2024	E		*	*	*

Chassis numbers

Manufacturer	Filler	Type	Filler	MY	Factory	From	To	Prod from	Prod to
SJA	AT2	ZV	5	R	C	027746	027746		
SJA	AB1	4V	8	R	C	028202	028202		
SJA	AB1	4V	3	R	C	028219	028219		
SJA	AB1	4V	1	R	C	028235	028235		
SJA	AB1	4V	7	R	C	028255	028255		
SJA	AB1	4V	8	R	C	028264	028264		
SJA	AB1	4V	2	R	C	028275	028275		
SJA	AB1	4V	3	R	C	028284	028284		
SJA	AB1	4V	9	R	C	028290	028290		
SJA	AB1	4V	0	R	C	028291	028291		
SJA	AU1	ZV	2	R	C	028294	028294		
SJA	AU1	ZV	X	R	C	028298	028298		
SJA	AB1	4V	1	R	C	028302	028302		
SJA	AB1	4V	2	R	C	028308	028308		
SJA	AU1	ZV	6	R	C	028315	028315		
SJA	AB1	4V	3	R	C	028317	028317		
SJA	AB1	4V	5	R	C	028318	028318		
SJA	AU1	ZV	X	R	C	028320	028320		
SJA	AB1	4V	0	R	C	028324	028324		
SJA	AB1	4V	6	R	C	028327	028327		
SJA	AB1	4V	8	R	C	028331	028331		
SJA	AB1	4V	9	R	C	028337	028337		
SJA	AB1	4V	6	R	C	028344	028344		
SJA	AB1	4V	1	R	C	028350	028350		
SJA	AU1	ZV	8	R	C	028364	028364		
SJA	AB1	4V	9	R	C	028371	028371		
SJA	AB1	4V	8	R	C	028393	028393		
SJA	AU1	ZV	6	R	C	028394	028394		
SJA	AB1	4V	7	R	C	028417	028417		
SJA	AB1	4V	2	R	C	028440	028440		
SJA	AB1	4V	4	R	C	028441	028441		
SJA	AB1	4V	6	R	C	028473	028473		
SJA	AB1	4V	2	R	C	028499	028499		
SJA	AU1	ZV	1	R	C	028500	028500		

SJA	AB1	4V	X	R	C	028511	028511		
SJA	AB1	4V	8	R	C	028524	028524		
SJA	AU1	ZV	8	R	C	028526	028526		
SJA	AB1	4V	5	R	C	028528	028528		
SJA	AB1	4V	1	R	C	028591	028591		
SJA	AT2	ZV	X	R	C	028679	028679		
SJA	AT2	ZV	8	R	C	028681	028681		

Documents

Document name
master.xml

Notes



Repair instructions

Technical background

The black 'S' badges are missing from the left and right hand front doors

Remedy

The black 'S' Badges are missing from the left and right hand front doors on a small number of vehicles, please refer to the Work section and conduct all instructions to completion

Customer notification

Ensure all affected vehicles are repaired during the Pre Delivery Inspection (PDI)

Or

In the event that vehicles have been handed over to the customer please note that customer notification is not required, in this scenario please ensure the work is conducted at the nearest opportunity

Warranty accounting instructions

Warranty type 710 or 790

Damage service number ED23

Damage code 00 66

Criteria 01

Time to apply the left and right hand black 'S' front door badges

Labour Operation Code 66 49 24 00 (Use 99 index until 05/12/24)

Time 20 TU

Genuine parts

Black 'S' badge - 36A 853 688 AF - Quantity 2

Parts supply

Not applicable

Parts despatch control

Not applicable

Repair instructions



Notes

Technical background

The black 'S' badges are missing from the left and right hand front doors

Check

If the vehicle is not already listed as repaired in the "Repair history" (in Elsa Pro) refer to the Identification section to check the presence of the left and right hand black 'S' front door badges

Should neither be evident please carry out the required work in accordance with these instructions

Genuine parts

Black 'S' badge - 36A 853 688 AF - Quantity 2

Work

1) Clean the area shown in Figure 1 using a non-wax wash solution

- Once clean the operative must dry the area thoroughly



Figure 1

NOTICE

The surface on which the badge is to be bonded must be free of all anti adhesive impurities, such as dirt, dust and grease - Clean the mating surface with 3M Isopropanol cleaner (or similar)



The vehicle body should be at room temperature for at least 1 hour to aid the bonding process

2) Referring to Figure 2 - Apply / stick the black 'S' front door badges at the location shown on the front left door and front right door

NOTICE

For clarity the measurements are as follows:

- 92 mm from the front door edge to the upper tip of the 'S' badge
- 7 mm upwards from the lower door edge

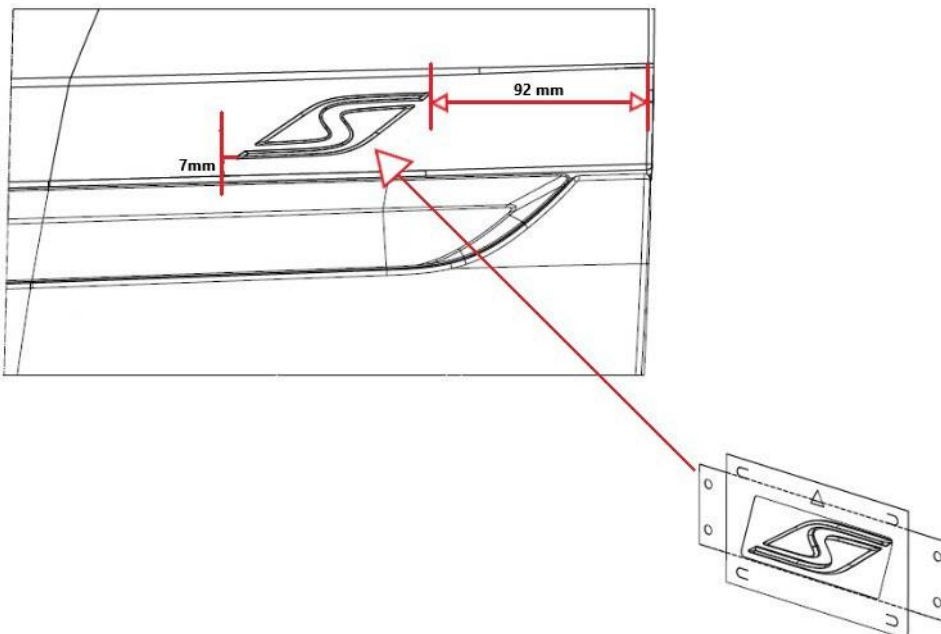

Figure 2

3) Fitment of the left and right hand black 'S' front door badges confirms completion

Identification

Fitment of the left (Figure 3) and right (Figure 4) black 'S' front door badges confirms completion



Figure 3



Figure 4