

54-366 J1939 Communication Errors with Cummins Engine Automated or Allison Transmission and Bendix Side Radar

TSB-54-366-FTL

Creation Date:2024-10-28

Engine or Vehicle Affected:

► New Cascadia

Warranty applies to this described condition. See the warranty information at the end of this bulletin.

Described Condition

The addition of third-party J1939 devices such as telematics can produce error frames, resulting in J1939 faults in New Cascadia vehicles equipped with a Cummins engine, Eaton automated or Allison transmission, and Bendix side radar. The solution involves replacing much of the existing J1939 datalink (dash, engine, and chassis) via overlay harnesses and jumpers, which reduces the overall backbone length and optimizes node locations and lengths, leading to significantly improved J1939 performance.

🔧 **Note:** The repair should be performed only after completing the troubleshooting outlined in the next section, and only if the troubleshooting specifically directs the repair.

🔴 **Important:** If a sticker on the dash indicates that the side radar is disconnected, you can skip the troubleshooting section and proceed directly to the parts lookup and work instructions. See Fig. 1

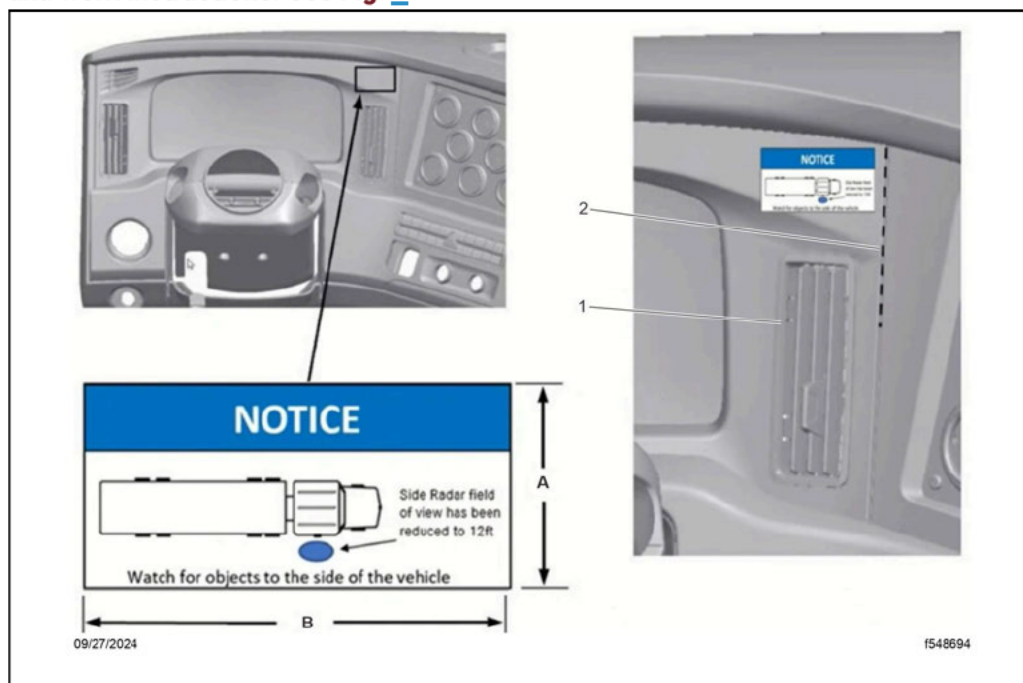

A. 1.5"

B. 3"

1. HVAC Vent

2. Instrument Panel Seam

Fig. 1, NOTICE Sticker

Troubleshooting Procedure to Determine if this Bulletin is Applicable

Note: Do not perform the repair outlined in this service bulletin unless specifically directed by the following troubleshooting procedure.

1. Has the vehicle experienced any or all of the following symptoms?
 - o The engine will not start.
 - o The ICUC display will cycle current gear from F to N.
 - o The transmission does not shift and is stuck in the current gear.

a. **YES** → Go to step 2.

b. **NO** → STOP HERE, this service bulletin is not applicable.

2. Does the vehicle have a Cummins diesel engine?

a. **YES** → Go to step 3.

b. **NO** → STOP HERE, this service bulletin is not applicable.

3. What transmission does this vehicle have?

a. **Eaton AMT (Endurant or Ultrashift)** → Go to step 4.

b. **Allsion** → Go to step 4.

c. **Manual** → STOP HERE, this service bulletin is not applicable.

4. Does this vehicle have Bendix side radar?

a. **YES** → Go to step 5.

b. **NO** → STOP HERE, this service bulletin is not applicable.

5. Does this vehicle have any third-party telematics connected to the J1939?

a. **YES** → Go to step 6.

b. **NO** → STOP HERE, this service bulletin is not applicable.

6. Measure the resistance on pins C and D of the diagnostic connector, with the ignition in the OFF position.

- **120 ± 5 ohms** → Install the missing terminating resistor. If symptoms persist, go to step 7.
- **60 ± 5 ohms** → Go to step 7.
- **40 ± 5 ohms** → Locate and remove the extra terminating resistor. Go to step 7.
- **30 ± 5 ohms** → Locate and remove the two extra terminating resistors. Go to step 7.
- **0 ohms** → J1939 is shorted. STOP HERE, this service bulletin is not applicable.
- **Open Circuit** → Repair J1939 wiring or missing terminating resistors, then go to step 7.

[Redacted]

7. Connect DiagnosticLink® to the vehicle and turn the keyswitch ON. Are the following fault codes active or become active while monitoring? See Table 1.

Table 1, Fault Code

SA	SPN	FMI	Description
37 (CGW)	523615	31	Received network data in error - XBR.
37 (CGW)	523515	31	CGW has detected an issue with the J1939 CAN, offline or performance.
3 (TCM)	639	9	J1939 Network #1, primary vehicle network (previously SAE J1939 data link) - abnormal update rate.
3 (TCM)	751	9	Transmission primary shift selector - abnormal update rate.

Table 1, Fault Code

[Redacted]

- a. **YES** → Go to step 8.

[Redacted]

- b. **NO** → STOP HERE, this service bulletin is not applicable.

[Redacted]

➤ **Note:** If none of the specific codes in the above table are present, even if similar codes are present, this service bulletin is not applicable.

8. Unplug the 2-pin J1939 connector from the Bendix side radar. Do the fault codes from the table step 7 become inactive? See Table [Fault Code 1](#).

[Redacted]

- a. **YES** → Go to step 9.

[Redacted]

- b. **NO** → Go to step 12.

[Redacted]

9. Connect the side radar 2-pin J1939 connector, then go to step 10.

[Redacted]

10. Unplug any third-party devices on J1939, see Table [Fault Code 1](#) and then go to step 11.

[Redacted]

11. Are the fault codes listed in the table step 7 active? See Table [Fault Code 1](#).

[Redacted]

- a. **NO** → Investigate third-party device integration, making sure that the connection to the third-party telematics is correct. Stub connection to the third-party telematics should not exceed 5.5 feet (1.7 m) in total length, including both DTNA access wiring, along with the third-party telematics. STOP HERE and proceed to **Per Serial Parts Lookup** in the next section of this service bulletin.

[Redacted]

- b. **YES** → STOP HERE, proceed to **Per Serial Parts Lookup** in the next section of this service bulletin

[Redacted]

12. Disconnect any J1939 third-party devices, go to step 13.

13. Do the fault codes listed in table [Fault Code 1](#) become inactive?

a. **YES** → STOP HERE, this service bulletin is not applicable. Investigate the third-party device and device integration.

b. **NO** → STOP HERE, this service bulletin is not applicable. There is an actual ECU device failing. Follow the appropriate troubleshooting for the remaining fault codes.

Per Serial Parts Lookup

🔧 **Note:** Prior to bringing the vehicle in to complete this repair procedure, look up the per serial parts list for the vehicle being repaired and order those parts. To determine what main harnesses, extension harnesses, jumpers, and other parts are required per vehicle serial number, see **J1939 Overlay Part Assignment By Serial EC** in [Parts Lookup Tool](#).

🔧 **Note:** See the following schematics (figure 2 to figure 5) throughout the repair to understand how the new J1939 overlays and jumpers tie into the existing J1939 datalink on the vehicle.

🔧 **Note:** Pay close attention to the vehicle's per serial parts list to help distinguish which options to follow in these schematics.

🔧 **Note:** There are two possible engine overlay harnesses, depending on engine model. Follow the engine schematic specific to your engine model.

Refer to figure 2 to figure 5 for layout and connection of harnesses, extensions, jumpers, etc. Also, referring to these figures throughout the installation will be helpful.

🔧 **Note:** If the vehicle has a Cummins X15 engine with an E-Viscous fan, the fan harness will need to be replaced. Order part number A66-39340-000.

Parts Lookup By Application

As an alternative to the per serial parts lookup tool in the previous section, Table [Parts List for J1939 Backbone by Application 2](#) can be used to look up the necessary parts by application.

Table 2, Parts List for J1939 Backbone by Application

Main Part #	Add On Part #	Description
A66-37409-000 (Required based on X12 engine type)		Service Harness, Engine, X12, Base
(Required for Allison transmission)	A66-37412-000	Service Harness, Engine, Allison, Extension
	A66-37414-000	Service Harness, Engine, Jumper, Extension
(Required for Endurant transmission)	A66-37413-000	Service Harness, Engine, Endurant, Extension
A66-37415-000 (Required based on X15 engine type)		Service Harness, Engine, X15, Base

Main Part #	Add On Part #	Description
(eViscous Fan)	A66-37416-000	Service Harness, Engine, EVIS FAN, Extension
Jumper to connection axiomatic controller for eViscous fan	A66-39340-000	EVIS Jumper Replacement
(No eViscous Fan)	A66-37414-000	Service Harness, Engine, Jumper, Extension
(Required for Allison Transmission)	A66-37412-000	Service Harness, Engine, Allison, Extension
	A66-37414-000	Service Harness, Engine, Jumper, Extension
(Required for Endurant Transmission)	A66-37413-000	Service Harness, Engine, Endurant, Extension
A66-37417-000 (Required on all vehicles)		Service Harness, Chassis, Base
(Wabco OnGuard)	A66-37418-000	Service Harness, Chassis, ACC, Extension
(No Wabco OnGuard)	A66-37414-000	Service Harness, Engine, Jumper, Extension
(TPMS) Day Cab / 48" Sleeper	A66-37419-000	Service Harness, Chassis, TPMS Day Cab, Extension
(TPMS) Sleeper / Greater Than 48"	A66-37420-000	Service Harness, Chassis, TPMS Long Sleeper, Extension
(No TPMS)	A66-37414-000	Service Harness, Engine, Jumper, Extension
(Bendix Side Radar)	A66-37421-000	Service Harness, Chassis, SODS, Extension
(Suspension Smart Valve or OptiMaax)	A66-37422-000	Service Harness, Chassis, HSV,HO, Extension
A66-37423-000 (Required on all vehicles)		Service Harness, Dash, Base
(No SRS air bag)	A66-37424-000	Service Harness, Dash, No Floor, Extension
(SRS air bag)	A66-37425-000	Service Harness, Dash, Floor content, Extension
(No Bendix Lane Departure or RP1226 overhead opt)	A66-37426-000	Service Harness, Dash, No Overhead, Extension
(Bendix Lane Departure or RP1226 overhead opt)	A66-37427-000	Service Harness, Dash, Overhead Content, Extension
(Wabco OnGuard)	A66-37428-000	Service Harness, Dash, CAWS, Extension
(Required on all vehicles)	A66-37429-000	Service Harness, Dash, AUDIO, Extension
(RP1226 1) (only one max of each of line 28 to 30)	A66-37431-000	Service Harness, Dash, TGS, Extension
(RP1226 2) (only one max of each of line 28 to 30)	A66-37430-000	Service Harness, Dash, TELS_1A, Extension
(RP1226 3) (only one max of each of line 28 to 30)	A66-37432-000	Service Harness, Dash, TELS_2A Extension
End cap \$ plug used to plug Allison transmission connection if not used		

Main Part #	Add On Part #	Description
DUF DTM04 2P E003 (23-13148-202)		End Cap RCPT-2CAV,DTM- 20,GR
DUF 0413 204 2005 (23-13218-200)		Cavity Plugs (Requires a quantity of two per cap)

Table 2, Parts List for J1939 Backbone by Application

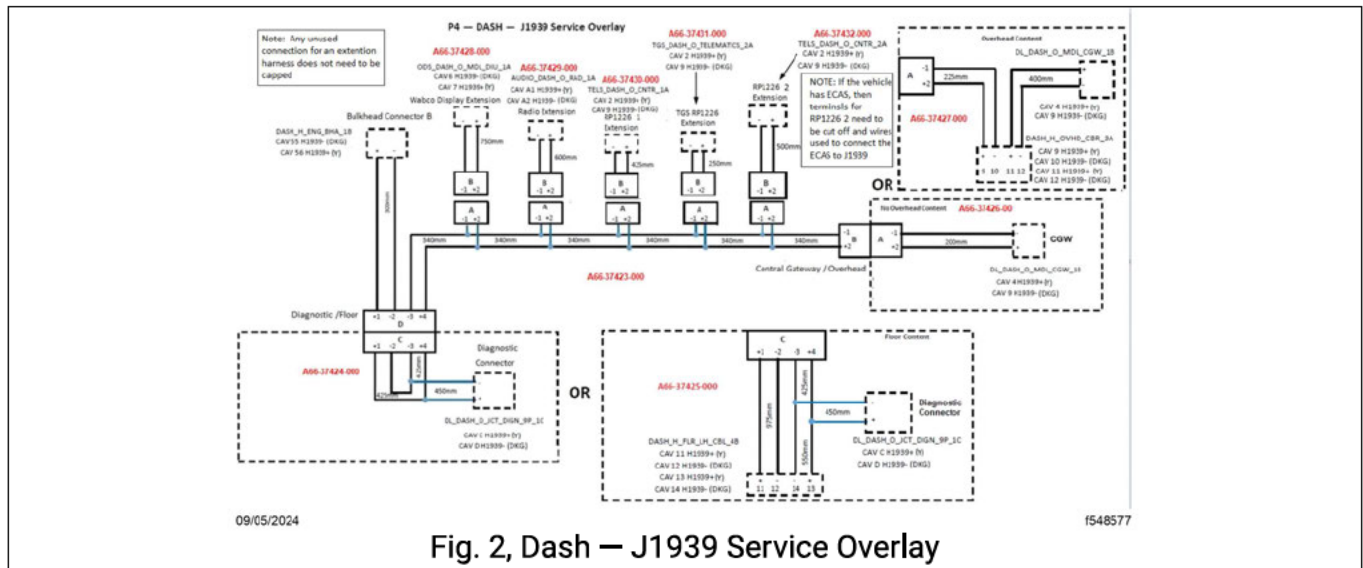

Fig. 2, Dash - J1939 Service Overlay

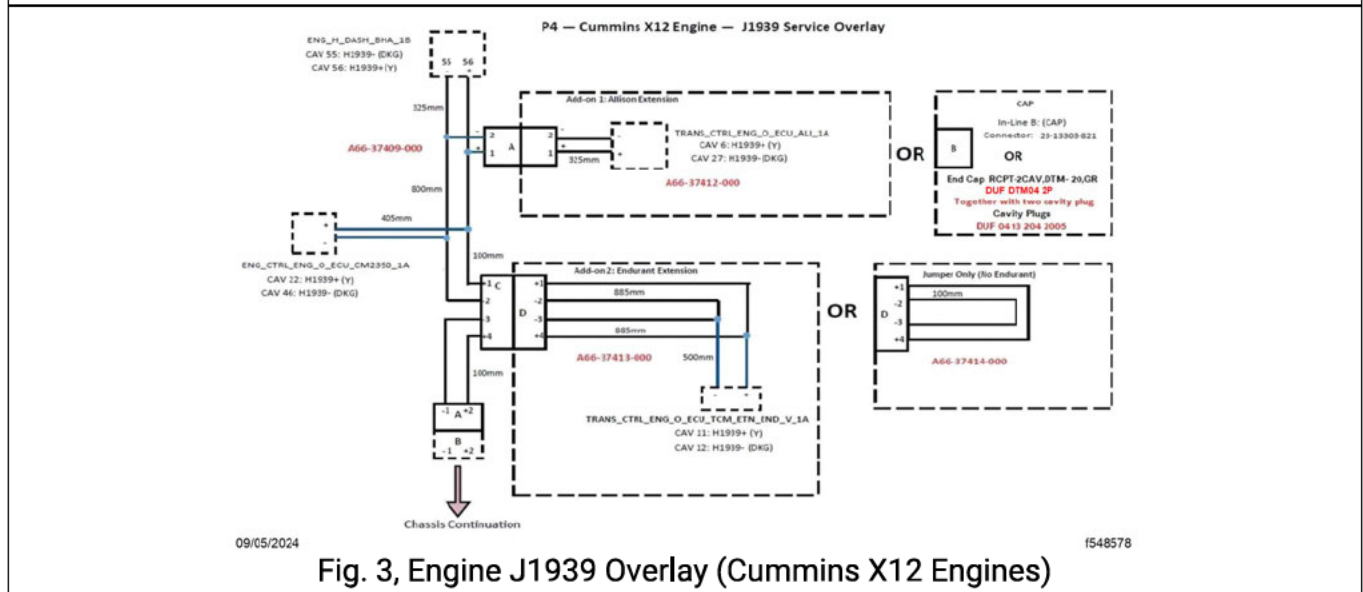

Fig. 3, Engine J1939 Overlay (Cummins X12 Engines)

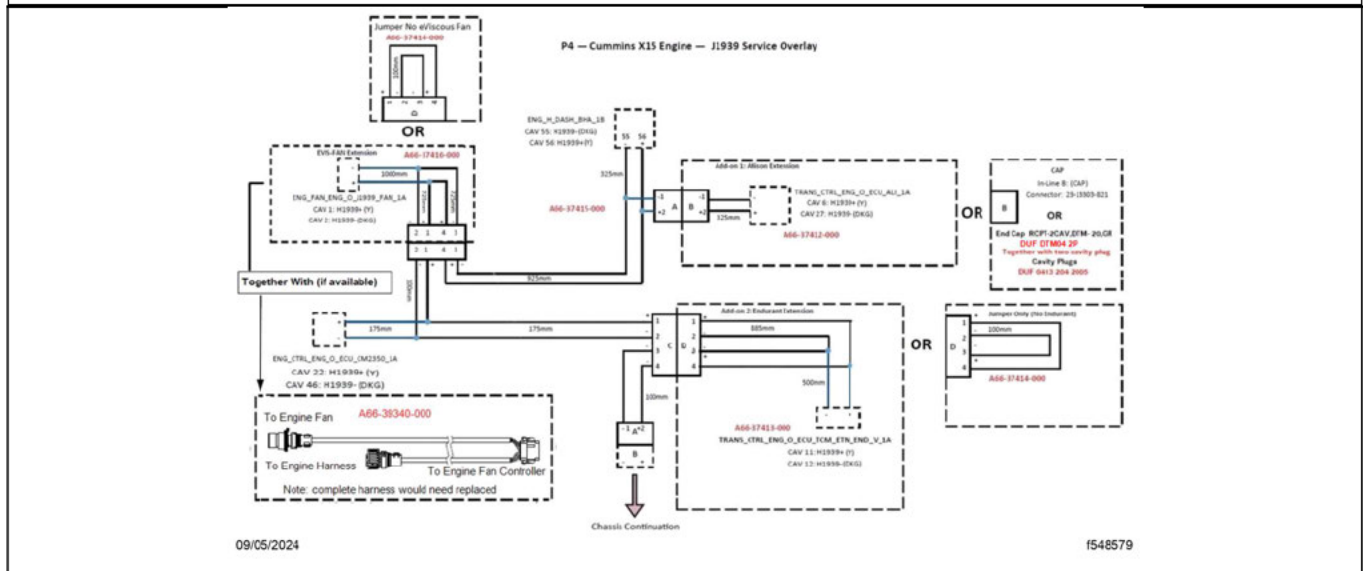

Fig. 4, Cummins X15 Engine – J1939 Service Overlay

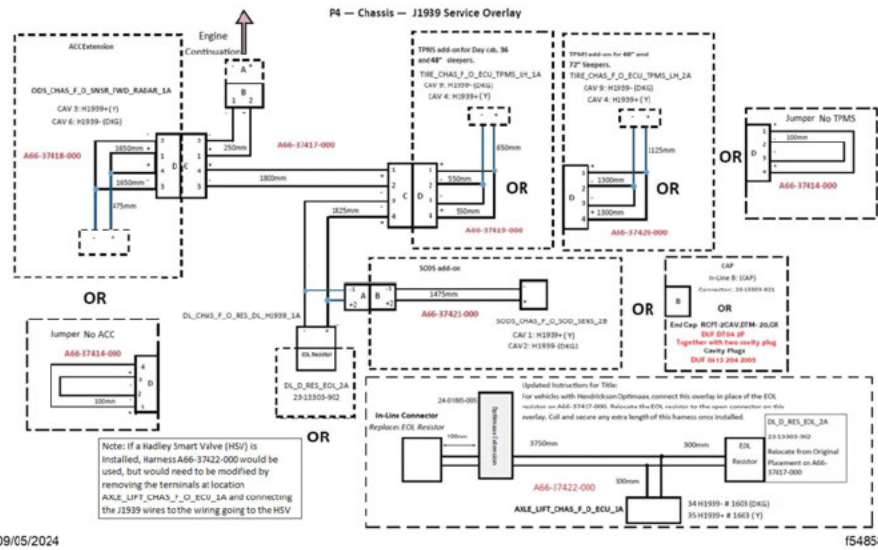

Fig. 5, Chassis – J1939 Overlay

👉 **Note:** The upper panel video includes top dash panel removal, which is not necessary for this installation.

👉 **Note:** These videos are intended for reference purposes only. They may not cover all details or might include more information than required.

1. Remove the following dash components.

54_Center Lower Dash Cover R&L



60_New Cascadia A-Pillar Lower Panel R&I



Powered by Panopto



60_New Cascadia Bolster Panel R&I



Powered by Panopto



60_New Cascadia Upper Dash Panel R&I



Powered by Panopto



a. Electrical bay cover

b. Radio

c. B-panel lower fascia (including MSF switch modules, and park brake knobs)

d. Fascia panel driver lower

- e. Fascia panel AUX upper
- f. AUX B panel insert (may be flat panel, Zonar tablet, or storage pockets)
- g. Fascia panel driver (ICU fascia panel)
- h. Instrument cluster
- i. Lower dash cover (including footwell light)
- j. Throttle cover
- k. Central lower dash cover
- l. Grab handle covers (left-hand (LH) side only if no overhead J1939 content)
- m. Grab handles (LH only if no overhead J1939 content)
- n. Cover sill (LH only if no overhead J1939 content)
- o. A-pillar covers (left side only if no overhead J1939 content)
- p. Driver side lower dash cover



Electrical Bay Cover



Footwell Lamp



Dash Lower Cover



Throttle Cover



Central Lower Dash Cover

Fig. 9, Dash – J1939 Service Overlay

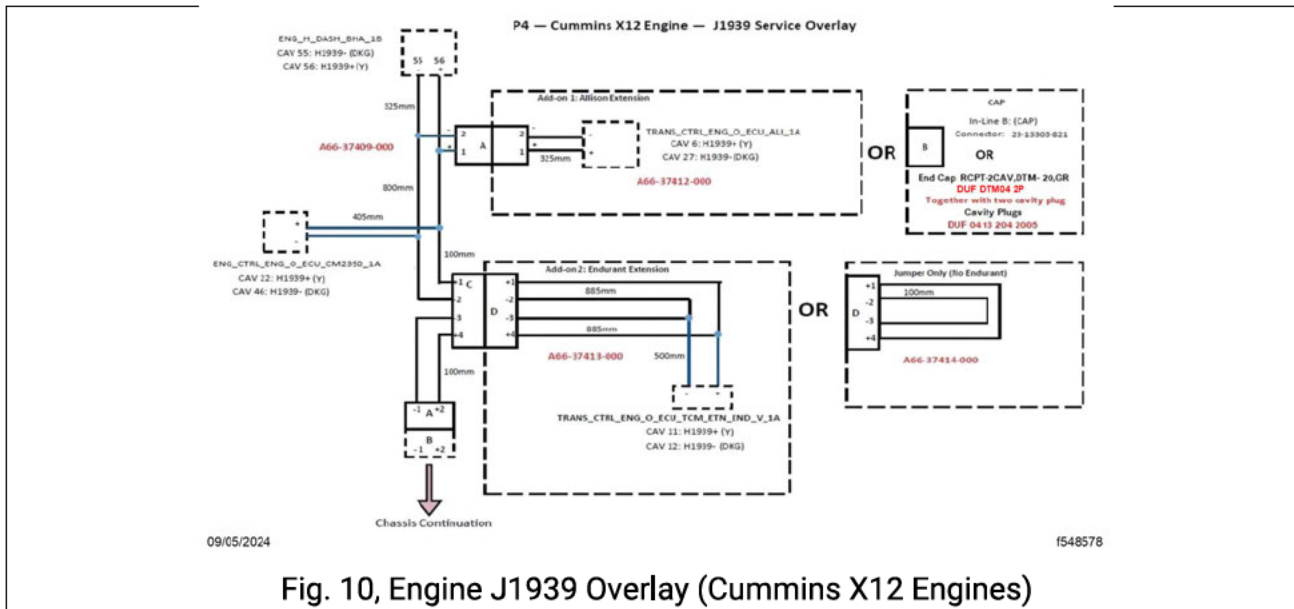

Fig. 10, Engine J1939 Overlay (Cummins X12 Engines)

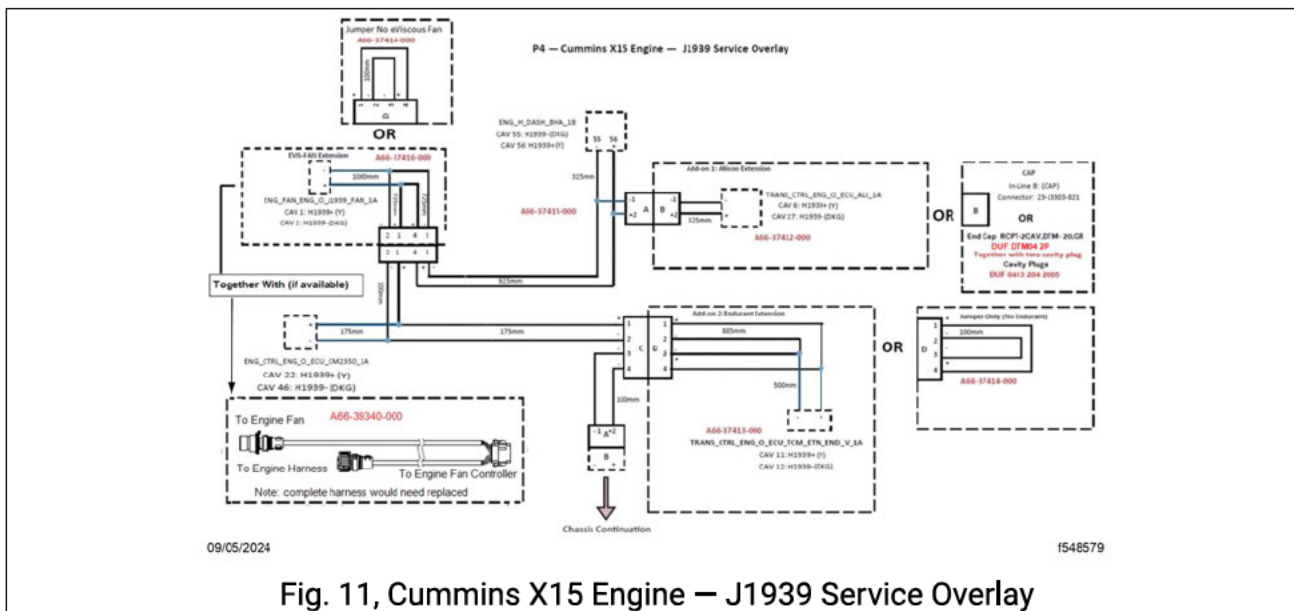

Fig. 11, Cummins X15 Engine – J1939 Service Overlay

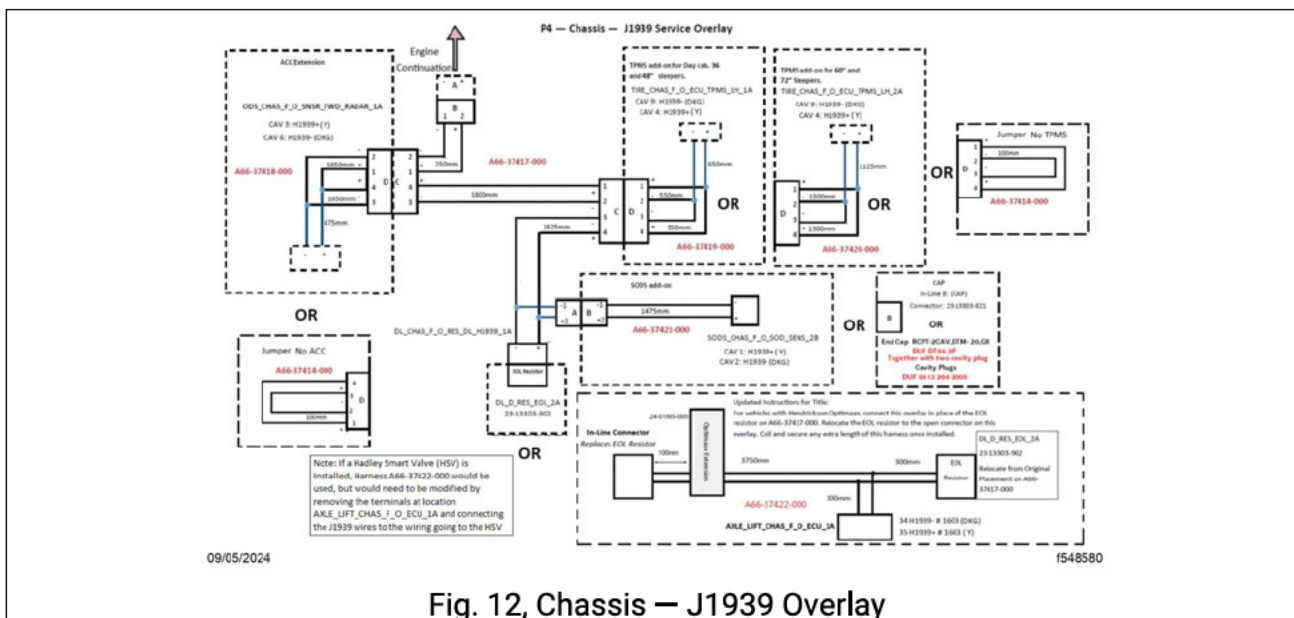

Fig. 12, Chassis – J1939 Overlay

2. Prepare the J1939 dash overlay for installation.

- a. Connect jumper A66-37424-000 (jumper to the diagnostic connector) or A66-37425-000 (jumper to the diagnostic connector and floor harness) to the dash overlay A66-37423-000. The correct jumper to be used is based on the vehicle content and vehicle specific parts list. See Fig. 9.
- b. Connect jumper A66-37426-000 (jumper to the CGW) or A66-37425-000 (jumper to the CGW and overhead harness) to the dash overlay A66-37423-000. The correct jumper to be used is based on the vehicle content and vehicle specific parts list. See Fig. 9.
- c. The remaining extension jumpers called out for the vehicle (A66-37428-000, A66-37429-000, A66-37430-000, A66-37431-000, and A66-37432-000) can be optionally installed to the dash overlay A66-37423-000 at this time, but it may be easier to route the overlay harness first, then install these extension jumpers.

☛ **Note:** Some vehicles will not use all the extension jumpers mentioned in step 2.c. Refer to the vehicle specific parts list for the extension jumpers need.

☛ **Note:** If an extension jumper is not called out in the vehicle specific parts list, just leave that 2-pin connector on the dash overlay unconnected.

3. Route the prepared dash overlay along the main dash harness.

- a. With the dash overlay harness A66-37423-000 prepared with at least the diagnostic connector jumper installed (A66-37424-000 or A66-37425-000) and the CGW jumper installed (A66-37427-000 or A66-37426-000), route this harness assembly from the lower right hand A-pillar area to the lower left hand A-pillar area, following the routing path of the existing main dash harness. See Fig. 13.

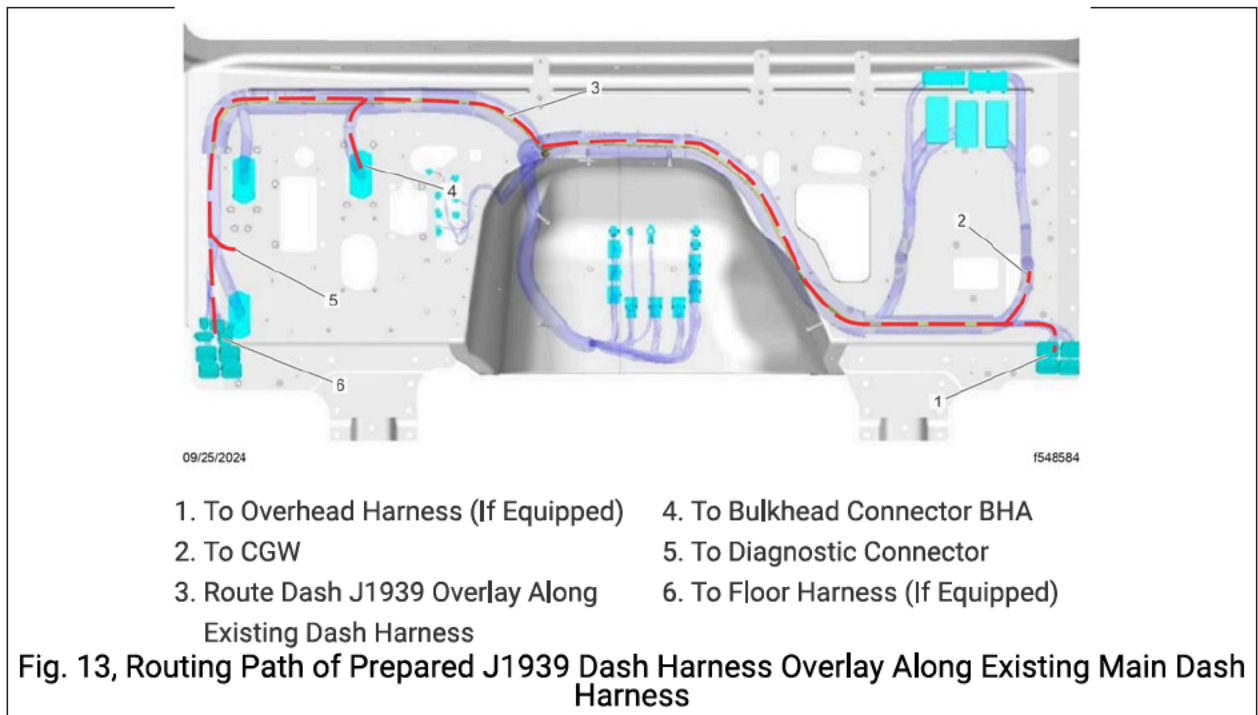

☛ **Note:** Be sure to route so that harness reaches all the connection points shown in Fig. 13.

- b. Secure the overlay to the main harness with zip ties.

4. Connect J1939 dash overlay to bulkhead connector BHA.

- a. Raise the hood, and disconnect the bulkhead connector BHA from the firewall. See Fig. [14](#).

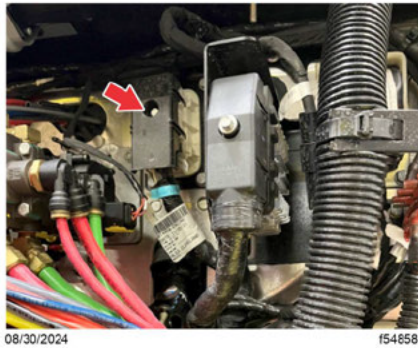

Fig. 14, Bulkhead Connector BHA

Note: Bulkhead connector BHA is the one directly above the steering shaft.

- b. Remove the four bolts that fasten the bulkhead connector BHA mounting plate to the firewall. Remove the mounting plate from the BHA connector. See Fig. [15](#).



Fig. 15, Removing Bulkhead Connector BHA Mounting Plate

- c. Pull the BHA connector shown in Fig. [15](#) through the firewall to the engine side and check if there is enough slack to remove and replace the J1939 wires on the connector. If not, the connector will need to be pulled up into the area behind the instrument cluster to make the wiring connections. Fig. [16](#) shows the connector pulled up into the area behind the instrument cluster.

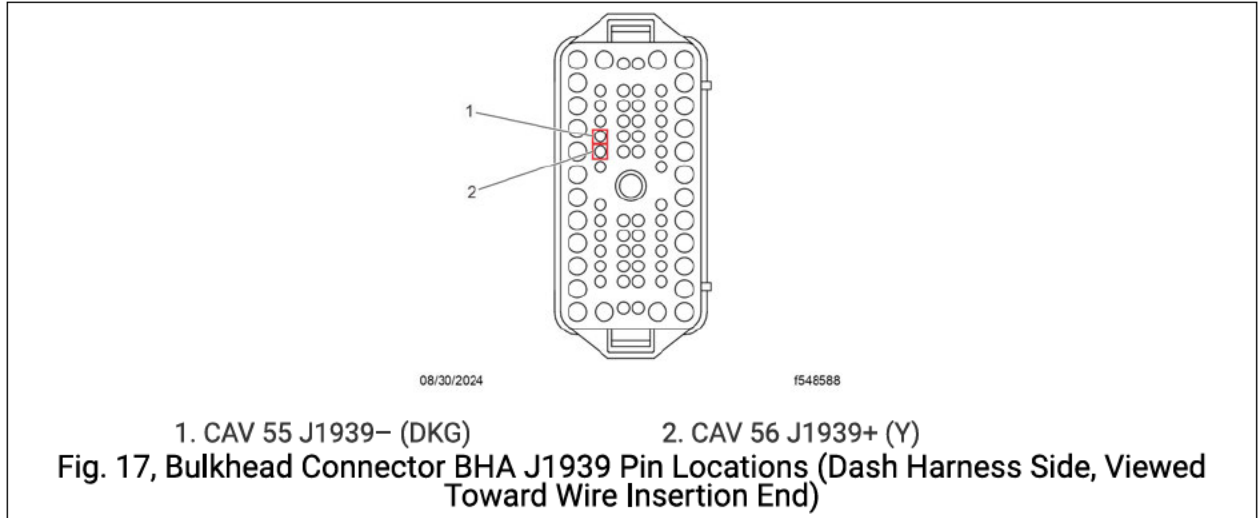

Fig. 16, Connector BHA Pulled Up into Area Behind the ICU for Access

Note: It may be necessary to remove some zip ties from the main harness to get enough slack to pull the BHA connector through the firewall or up into the back of the instrument cluster area in order to make wiring connections.

- d. Remove the red terminal guide from the face of the connector by carefully prying with a pick or small flat bladed terminal tool.

- e. Locate the existing J1939 wires in the back of the connector. See Fig. 17. From the front side of the connector, carefully release the terminals and remove the wires using a small flat bladed terminal tool such as.



- f. Cut the terminals off the existing J1939 wires removed in step 4.e and tape them back to the existing harness.

- g. Insert the J1939 wires from J1939 dash overlay harness A66-37423-000 into the BHA cavities: J1939- (DKG) into cavity 55 and J1939+ (Y) into cavity 56. Make sure the terminal engages into the connector tangs.

- h. Reinstall the red terminal guide.

- i. Reinstall the dash side of the bulkhead BHA connector and mounting plate to the firewall.

- j. Secure any excess J1939 overlay wiring leading to the BHA connector with zip ties as needed.

5. Connect the J1939 dash overlay to the diagnostic connector and floor connector (if equipped).

- a. Using the terminal tool DK10CHA17002-10, release and remove the existing J1939 wires from the diagnostic connector cavities C and D as shown in Fig. 18, Fig. 19, and Fig. 20.

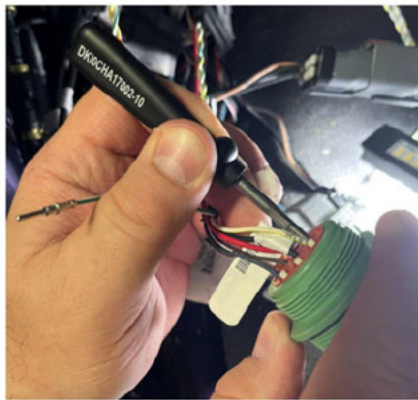

08/30/2024

f546589

Fig. 18, Releasing and Removing J1939 Wires From the Diagnostic Connector Using Terminal Tool DK10CHA17002-10

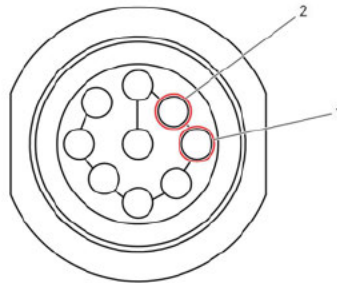

08/30/2024

f546590

1. CAV D J1939- (DKG)

2. CAV C J1939+ (Y)

Fig. 19, Diagnostic Connector J1939 Pin Locations (View from Wire Insertion End)

- b. Cut the terminals off the existing J1939 wires removed in step 5.a and tape them back to the existing harness.
- c. Insert the J1939 wires from jumper harness A66-37424-000 or A66-37425-000 into cavities C and D on the diagnostic connector: J1939+ (Y) into the cavity C and J1939- (DKG) into cavity D. Make sure the terminals engage into the connector. See Fig. [9](#), [19](#) and Fig. [20](#).
- d. Secure any excess J1939 overlay wiring leading to the diagnostic connector with zip ties as needed.
- e. If jumper A66-37425-000 was installed, continue to step 5.f for connection to the floor harness. Otherwise, go to step 6.
- f. Locate the floor harness connector shown in Fig. [20](#).

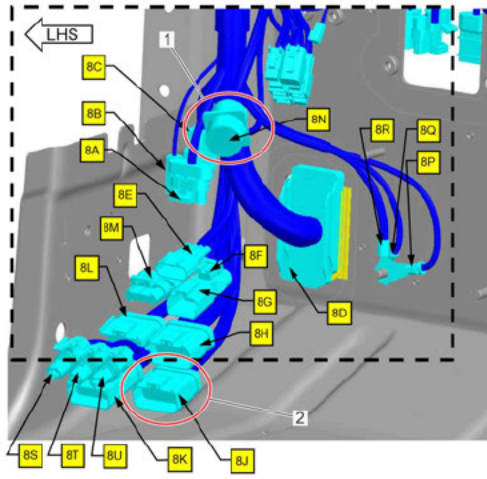

PAGE INDEX LETTER	REFERENCE DESIGNATOR	REF MOD
8A	HVAC_AUX_DASH_O_FLR_MOT_1A	70C
8B	DASH_H_DR_LH_CBL_4B	73F
8C	DASH_H_DR_LH_CBL_1B	K010
8D	DASH_H_CHAS_F_BHM_1A	K001
8E	SPNSN_DASH_O_FLR_ECAS_1A	87D
8F	SRS_DASH_O_FLR_LH_IFL_LP_1A	725
8G	GND_INT_DASH_O_FLR_GNDI_GNDP_1A	28G
8H	DASH_H_FLR_LH_CBL_2B	K008
8J	DASH_H_FLR_LH_CBL_4B	K009
8K	DASH_H_FLR_LH_CBL_3B	K037
8L	DASH_H_FLR_LH_CBL_1B	K007
8M	TFLR_DASH_O_FLR_LH_CBL_1A	296
8N	DL_DASH_O_JCT_DIGN_9P_1C	43R
8P	GND_INT_DASH_O_STUD_GNDP_8A	28G
8Q	GND_INT_DASH_O_STUD_GNDP_6A	28G
8R	GND_INT_DASH_O_STUD_GNDP_7A	28G
8S	WSHLD_DASH_O_FLR_2A	XXX
8T	WSHLD_DASH_O_FLR_1A	XXX
8U	WSHLD_DASH_O_FLR_3A	XXX

1. DL_DASH_O_JCT_DIGN_9P_1C 2. DASH_H_FLR_LH_CBL_4B
Fig. 20, Diagnostic Connector and Floor Harness Connector Locations

- g. Unplug the floor harness connector.
- h. Remove the two pairs of existing J1939 wires from the main dash harness side of the floor harness connector, cavities 11, 12, 13, and 14. See Fig. 21.
- i. Cut the terminals off the existing J1939 wires removed in step 5.h and tape them back to the existing harness.
- j. Insert the four J1939 wires from jumper A66-37425-000 into the floor harness connector as follows: CAV 11 J1939+ (Y), CAV 12 J1939- (DKG), CAV 13 J1939+ (Y), and CAV 14 J1939- (DKG). See Fig. 9 and Fig. 21.

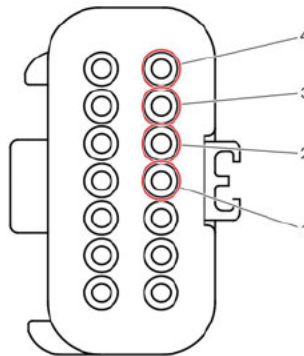

- 1. CAV 11 J1939+ (Y)
- 2. CAV 12 J1939- (DKG)
- 3. CAV 13 J1939+ (Y)
- 4. CAV 14 J1939- (DKG)

Fig. 21, Floor Harness Connector J1939 Pin Locations

- k. Secure any excess J1939 overlay wiring leading to the floor harness connector with zip ties as needed.
 - l. Reconnect the floor harness connector
6. Connect the J1939 dash overlay to the CGW and overhead connector (if equipped).
- a. Disconnect the CGW electrical connector. For instructions, see Chapter 20: Section 11 in the New Cascadia *Workshop Manual*.

Note: It may be necessary to remove the CGW from its position in the Ebay in order to remove the electrical connector.

- b. The CGW connector contains two separate connectors within the main housing, one gray and one black. Release the gray connector and remove it from the main housing. See Fig. 22 and Fig. 23.

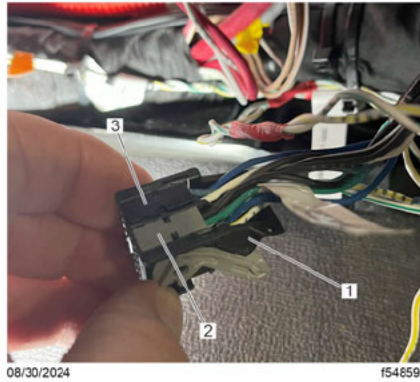

1. CGW Connector Main Housing 3. Black Connector
2. Gray Connector

Fig. 22, Gray and Black Connectors Within The Main CGW Connector Housing

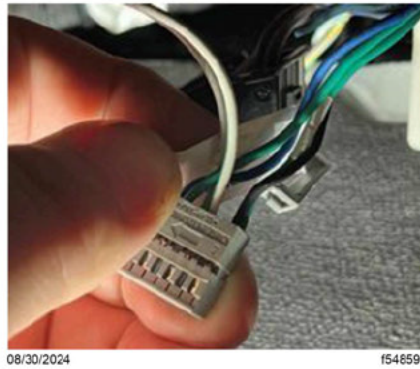
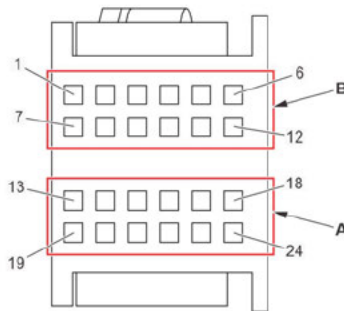

Fig. 23, Gray Connector Removed from Main CGW Connector Housing

- c. Locate the J1939 wires in the gray connector cavities 4 and 9. See Fig. 24.

- d. Remove the J1939 wires from the connector cavities 4 and 9 using a small terminal tool such as DK10CHA17002-2 or a pick to gently press the terminal tangs in the location shown in Fig. 25 to release the terminal and wire from the connector.



A. Black Connector

B. Gray Connector

Fig. 24, CGW Connector Pinout: CAV 4 J1939+ (Y) And CAV 9 J1939- (DKG)

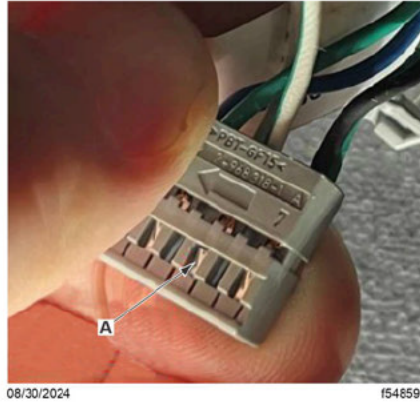

A. Gently press here and pull the wire to release it from the connector.

Fig. 25, Releasing Terminal and Wire from the CGW Gray Connector

- e. Cut the terminals off the wires removed in step 6.d and tape them back on the harness.
 - f. Insert the J1939 wires from jumper harness A66-37426-000 or A66-37427-000 into cavities 4 and 9 on the gray CGW connector: J1939+ (Y) into cavity 4 and J1939- (DKG) into cavity 9. Make sure the terminals engage into the connector. See Fig. 24.
 - g. Reinstall the gray connector into the main CGW connector housing.
 - h. Plug the CGW connector into the CGW.
- Note:** Reinstall the CGW into position in the electrical bay if it was previously removed.
- i. Secure any excess J1939 overlay wiring leading to the CGW with zip ties as needed.
 - j. If jumper A66-37427-000 was installed, continue to step 6.k for connection to the overhead harness. Otherwise, go to step 7.
 - k. Locate the overhead harness connector in the lower passenger side area as shown in Fig. 26.

PAGE INDEX LETTER	REFERENCE DESIGNATOR	REF. MOD
25A	DASH_H_BCA_C_1A	285
20B	BAT_DASH_O_BCA_D_1A	308
20C	DASH_H_BCA_B_1A	285
20D	DASH_H_BCA_A_1A	285
20E	DL_DASH_O_MDL_CGW_1B	43R
20F	EGS_DASH_D_JMPR_OCM_1B	78A
20G	DASH_H_OVHD_CBR_3A	K004
20H	DASH_H_OVHD_CBR_4B	K003
20J	DASH_H_OVHD_CBR_2A	K005
20K	DASH_H_OVHD_CBR_1A	K008
20L	DASH_H_FLR_RH_CBR_2B	K008
20M	DASH_H_FLR_RH_CBR_4B	K009
20N	DASH_H_FLR_RH_CBR_3B	K024
20P	DASH_H_FLR_RH_CBR_1B	K007
20Q	DL_DASH_O_SP_1939_1A	#181
20R	DASH_H_DR_RH_CBR_1B	K011
20S	DASH_H_DR_RH_CBR_4B	73F

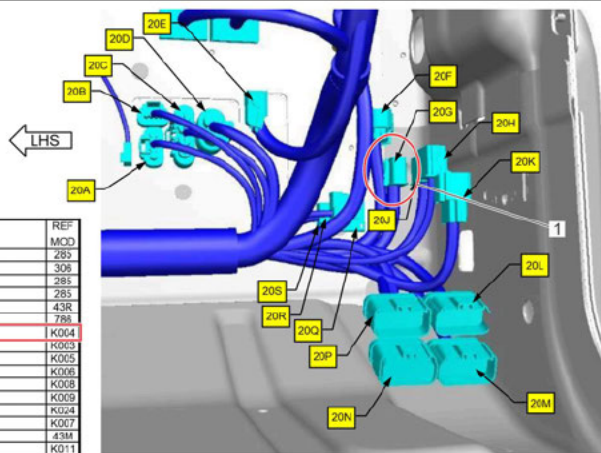

1. DASH_H_OVHD_CBR_3A

Fig. 26, Overhead Harness Connector Location

- l. Unplug the overhead harness connector.
- m. Remove the two pairs of existing J1939 wires from the main dash harness side of the overhead connector, cavities 9, 10, 11, and 12. See Fig. 27.

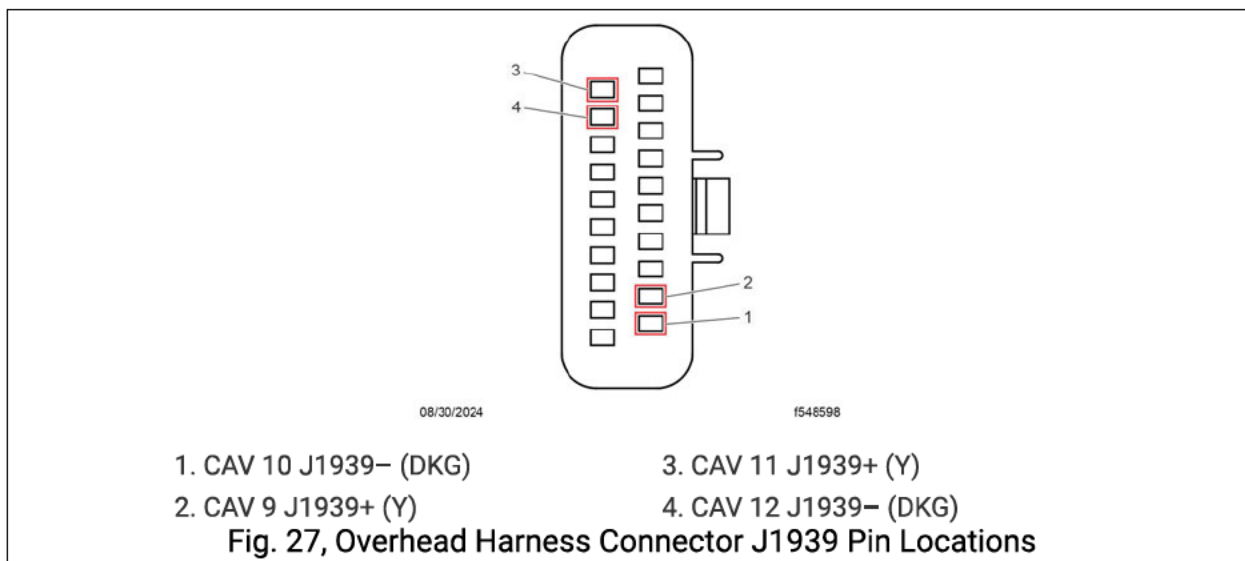

- n. Cut the terminals off the existing J1939 wires removed in step 6.m and tape them back to the existing harness.

Note: When installing the paired J1939 wires (part number of jumper A66-37427-000) into the overhead connector, the twisted pairs need to be installed in the correct locations. Cavities 9 and 10 need to be twisted pair, and 11 and 12 need to be a twisted pair. Cavities 11 and 10 have larger terminals than 9 and 12. If, for any reason, the wires do not come with the correct terminal ends, they need to be corrected before installing. See Fig. 27.

- o. Insert the four J1939 wires from the jumper A66-37427-000 into the overhead harness connector as follows: CAV 9 J1939+ (Y), CAV 10 J1939- (DKG), CAV 11 J1939+ (Y), and CAV 12 J1939- (DKG). See Fig. 9 and Fig. 27.

- p. Secure any excess J1939 overlay wiring leading to the overhead harness connector with zip ties as needed.

- q. Reconnect the overhead harness connector.

7. Connect the dash J1939 overlay to the Wabco display (if equipped).

- a. If the extension jumper A66-37428-000 (Wabco display extension) was called out in the vehicle specific parts list, continue to step 7.b. If not, go to step 8.

- b. Connect the extension jumper A66-37428-000 to the main dash J1939 overlay. Make sure to plug it into the correct connector on the main J1939 dash overlay (pay attention to the connector labels).

- c. Disconnect the connector from the back of the Wabco display if not already done when dash panels were disassembled.

- d. Route the extension jumper A66-37428-000 to the Wabco display connector.

- e. Remove the red terminal guide from the Wabco display connector as shown in Fig. 28 and Fig. 29.

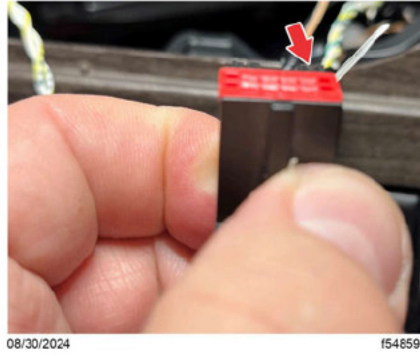

Fig. 28, Wabco Display Connector With Terminal Guide Installed

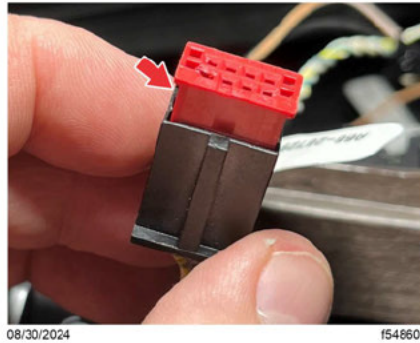
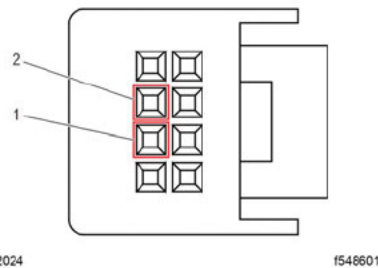

Fig. 29, Wabco Display Connector With Terminal Guide Pulled Out And Ready To Remove

- f. Locate the J1939 wires in the connector cavities 6 and 7. See Fig. 30.



1. CAV 7 J1939+ (Y)

2. CAV 6 J1939- (DKG)

Fig. 30, Wabco Display Connector J1939 Pin Locations

- g. Remove the J1939 wires from the connector cavities 6 and 7 using a small terminal tool such as DK10CHA17002-2 to release the terminal tangs as shown in Fig. 31.

- h. Cut the terminals off the existing J1939 wires removed in step 7.g and tape them back to the existing harness.

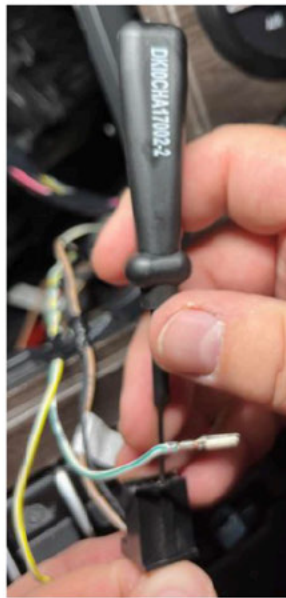

08/30/2024

f548602

Fig. 31, Removing J1939 Wires from Wabco Display Connector Using Terminal Tool DK10CHA17002-2

i. Insert the J1939 wires from jumper harness A66-37428-000 into cavities 6 and 7 of the Wabco display connector: J1939- (DKG) into cavity 6 and J1939+ (Y) into cavity 7. Make sure the terminals engage into the connector. See Fig. [30](#).

j. Reinstall the red terminal guide. See Fig. [28](#).

k. Plug the connector into the Wabco display.

l. Secure any excess J1939 overlay wiring leading to the Wabco display with zip ties as needed.

8. Connect the dash J1939 overlay to the radio (if equipped).

a. If the vehicle is equipped with a radio and the extension jumper A66-37429-000 (radio extension) was called out in the vehicle specific parts list, continue with step 8.b. Otherwise skip to step 9.

b. Connect the extension jumper A66-37429-000 (radio extension) to the main dash J1939 overlay. Make sure to plug it into the correct connector on the main J1939 dash overlay (pay attention to the connector labels).

c. Disconnect the black 16-pin connector from the back of the radio if not already done when dash panels were disassembled. See Fig. [32](#).



08/30/2024

f548603

Fig. 32, Black 16-Pin Radio Connector

- d. Route the extension jumper A66-37429-000 (radio extension) to the black 16-pin radio connector.

- e. Locate the J1939 wires in the black 16-pin radio connector cavities A1 and A2. See Fig. 33.

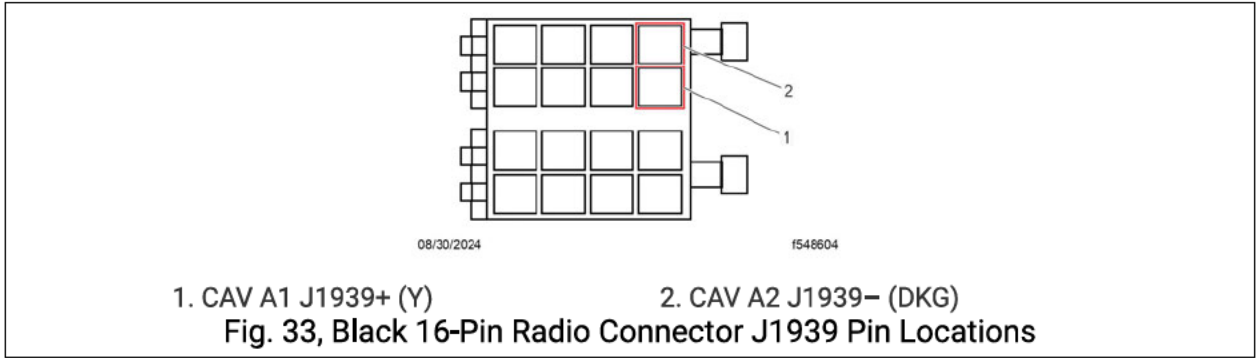

- f. Remove the J1939 wires from the connector cavities A1 and A2 using terminal removal tool such as DK10CHA17002-5 to release the terminal tangs as shown in Fig. 34.

- g. Cut the terminals off the existing J1939 wires removed in step 8.f and tape them back to the existing harness.

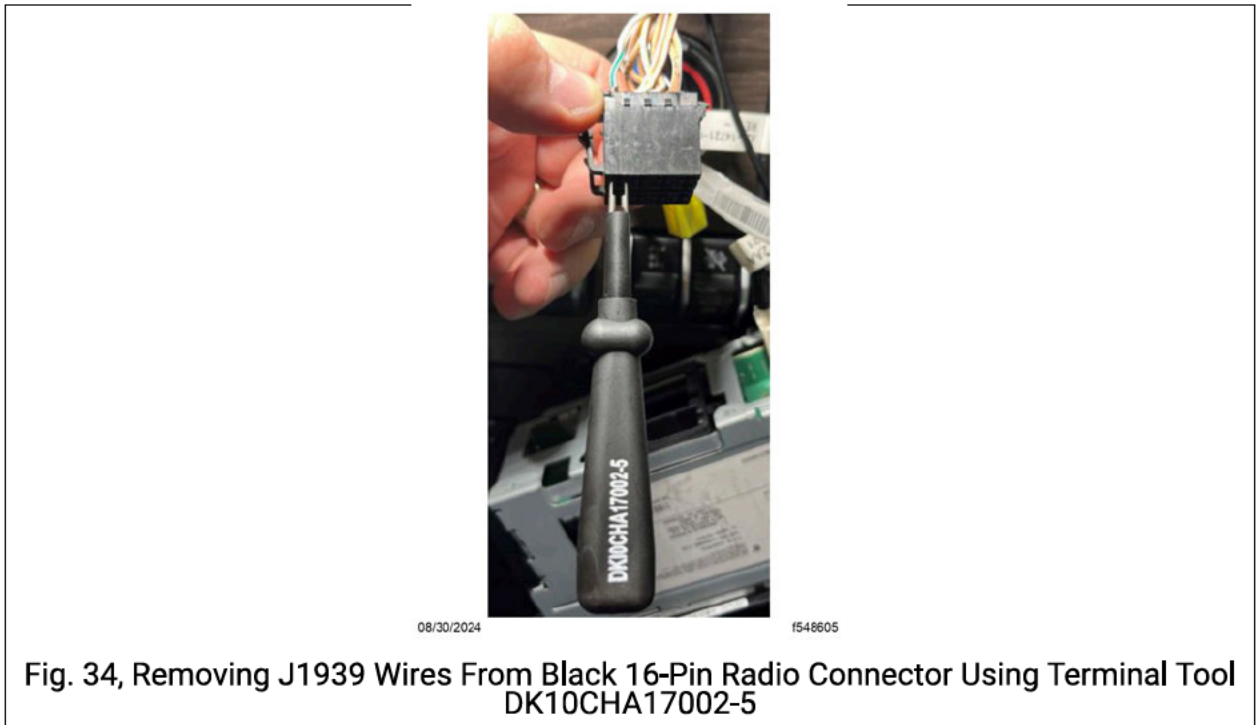

- h. Insert the J1939 wires from jumper harness A66-37429-000 into cavities A1 and A2 of the black 16-pin radio connector: J1939+ (Y) into cavity A1 and J1939- (DKG) into cavity A2. Make sure the terminals engage into the connector. See Fig. 33.

- i. Plug the black connector into the radio.

- j. Secure any excess J1939 overlay wiring leading to the radio with zip ties as needed.

9. Connect the dash J1939 overlay to the RP1226 1 connector (if equipped).

- a. If the vehicle is equipped with a RP1226 1 connector and the extension jumper A66-37430-000 (RP1226 1 extension) was called out in the vehicle specific parts list, continue with step 9.b. Otherwise skip to step 10.

b. Connect the extension jumper A66-37430-000 (RP1226 1) to the main dash J1939 overlay. Make sure to plug it into the correct connector on the main J1939 dash overlay (pay attention to the connector labels).

c. Locate the RP1226 1 connector. The wiring to this connector will typically branch out of the main dash harness just to the left of the electrical bay as shown in Fig. 35 and Fig. 36.



Fig. 35, Typical Location of the RP1226 Connectors that Branch Off the Main Dash Harness

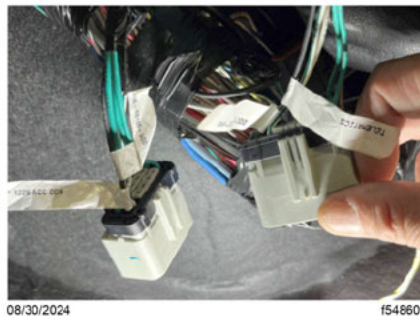

Fig. 36, Typical RP1226 Connectors (RP1226 1 and TGS RP1226 Shown)

Note: The RP1226 connectors may or may not be connected to anything, depending on factory and customer installed options.

d. If the RP1226 1 connector is connected to another harness, disconnect the other harness temporarily.

e. Route the extension jumper A66-37430-000 (RP1226 1) from the main dash J1939 overlay to the RP1226 1 connector (main dash harness side).

f. Locate the J1939 wires in the RP1226 1 connector cavities 2 and 9. See Fig. 37.

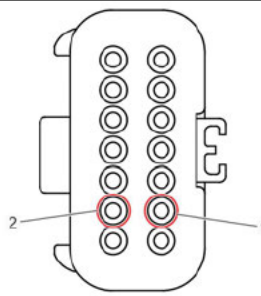

08/30/2024

1548608

1. CAV 9 J1939- (DKG)

2. CAV 2 J1939+ (Y)

Fig. 37, Typical RP1226 Connector J1939 Pinout Locations

g. Remove the J1939 wires from the RP1226 1 connector cavities 2 and 9.

h. Cut the terminals off the existing J1939 wires removed in step 9.g and tape them back to the existing harness.

i. Insert the J1939 wires from extension jumper A66-37430-000 into cavities 2 and 9 RP1226 1 connector: J1939+ (Y) into cavity 2 and J1939- (DKG) into cavity 9. Make sure the terminals engage into the connector. See Fig. [37](#).

j. If the RP1226 1 connector was previously disconnected from a mating connector, reconnect it to the mating connector.

k. Secure any excess J1939 overlay wiring leading to the RP1226 1 connector with zip ties as needed.

10. Connect the dash J1939 overlay to the TGS RP1226 connector (if equipped).

a. If the vehicle is equipped with a TGS RP1226 connector and the extension jumper A66-37431-000 (TGS RP1226 extension) was called out in the vehicle specific parts list, continue with step 10.b. Otherwise skip to step 11.

b. Connect extension jumper A66-37431-000 (TGS RP1226) to the main dash J1939 overlay. Make sure to plug it into the correct connector on the main J1939 dash overlay (pay attention to the connector labels).

c. Locate the TGS RP1226 connector. The wiring to this connector will typically branch out of the main dash harness just to the left of the electrical bay as shown in Fig. [35](#) and Fig. [36](#).

Note: The RP1226 connectors may or may not be connected to anything, depending on factory and customer installed options.

d. If the TGS RP1226 connector is connected to another harness, disconnect the other harness temporarily.

e. Route the extension jumper A66-37431-000 (TGS RP1226) from the main dash J1939 overlay to the TGS RP1226 connector (main dash harness side).

f. Locate the J1939 wires in the TGS RP1226 connector cavities 2 and 9. See Fig. [37](#).

g. Remove the J1939 wires from the TGS RP1226 connector cavities 2 and 9.

h. Cut the terminals off the existing J1939 wires removed in step 10.g and tape them back to the existing harness.

- i. Insert the J1939 wires from extension jumper A66-37431-000 into cavities 2 and 9 TGS RP1226 connector: J1939+ (Y) into cavity 2 and J1939- (DKG) into cavity 9. Make sure the terminals engage into the connector. See Fig. [37](#).
- j. If the TGS RP1226 connector was previously disconnected from a mating connector, reconnect it to the mating connector.
- k. Secure any excess J1939 overlay wiring leading to the TGS RP1226 connector with zip ties as needed.

11. Connect the dash J1939 overlay to the RP1226 2 connector or ECAS (if equipped).

- a. If the vehicle is equipped with a RP1226 2 connector or is equipped with ECAS, and extension jumper A66-37432-000 (RP1226 2 extension) was called out in the vehicle specific parts list, continue with step 11.b. Otherwise skip to step 12.
- b. Connect the extension jumper A66-37432-000 (RP1226 2) to the main dash J1939 overlay. Make sure to plug it into the correct connector on the main J1939 dash overlay (pay attention to the connector labels).
- c. If the vehicle has ECAS, go to step 11.d. If the vehicle does not have ECAS and instead has the RP1226 2 connector, skip to step 11.e.
- d. Connection to ECAS; cut the terminals off the end of the A66-37432-000 extension harness. Cut the existing J1939 wires leading to the ECAS. Splice the A66-37432-000 extension to the J1939 wires leading to the ECAS using splice methods. For instructions see Chapter 20: Group 54 Electrical, Instruments, and Controls, Section 20.1; Wiring in the *New Cascadia Workshop Manual* section. Secure any excess wiring using zip ties. Then go to step 12.
- e. Locate the RP1226 2 connector. The wiring to this connector will typically branch out of the main dash harness just to the left of the electrical bay as shown in Fig. [35](#) and Fig. [36](#).

Note: The RP1226 connectors may or may not be connected to anything, depending on factory and customer installed options.

- f. If the RP1226 2 connector is connected to another harness, disconnect the other harness temporarily.
- g. Route the extension jumper A66-37432-000 (RP1226 2) from the main dash J1939 overlay to the RP1226 2 connector (main dash harness side).
- h. Locate the J1939 wires in the RP1226 2 connector cavities 2 and 9. See Fig. [37](#).
- i. Remove the J1939 wires from the RP1226 2 connector cavities 2 and 9.
- j. Cut the terminals off the existing J1939 wires removed in step 11.g and tape them back to the existing harness.
- k. Insert the J1939 wires from the extension jumper A66-37432-000 into cavities 2 and 9 of the RP1226 2 connector: J1939+ (Y) into cavity 2 and J1939- (DKG) into cavity 9. Make sure the terminals engage into the connector. See Fig. [37](#).
- l. If the RP1226 2 connector was disconnected from a mating connector, connect it to the mating connector.
- m. Secure any excess J1939 overlay wiring leading to the TGS RP1226 connector with zip ties as needed.

12. Route the engine overlay.

- a. □ Route engine overlay A66-37409-000 (Cummins X12) or A66-37415-000 (Cummins X15) between bulkhead connector BHA and the Cummins ECM connector as shown in Fig. 38, Fig. 39, Fig. 40 and Fig. 41 .

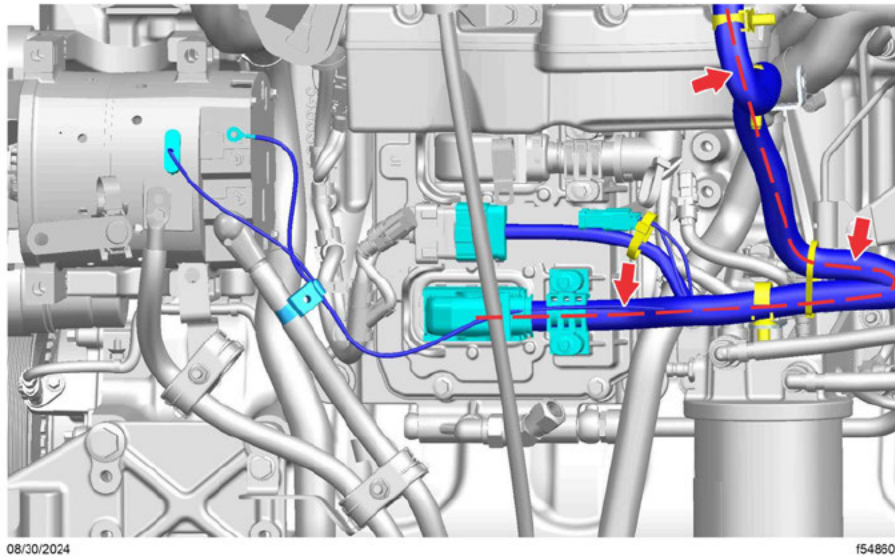
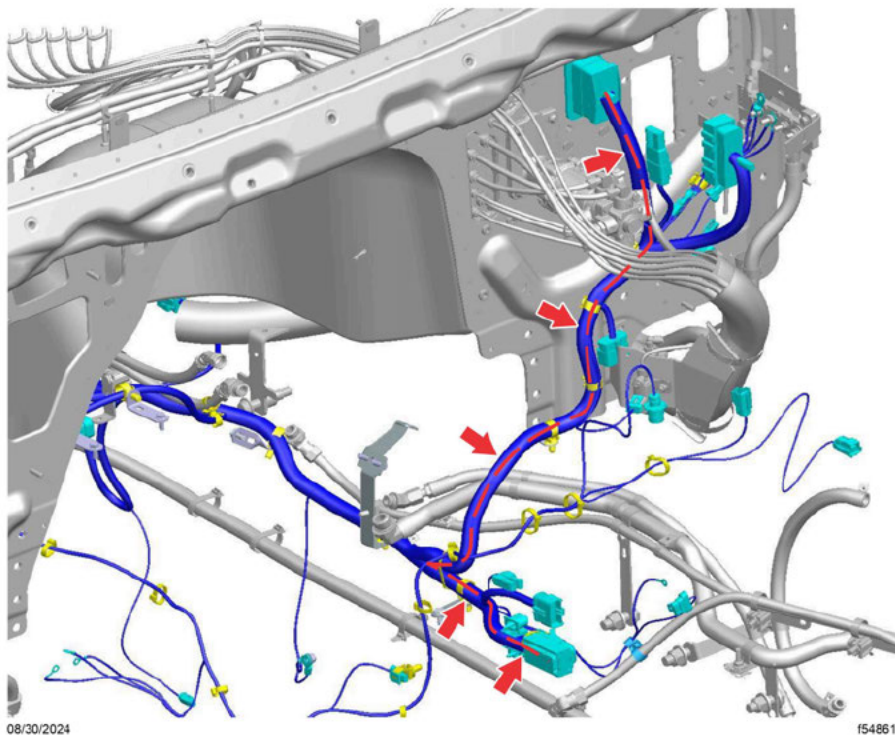
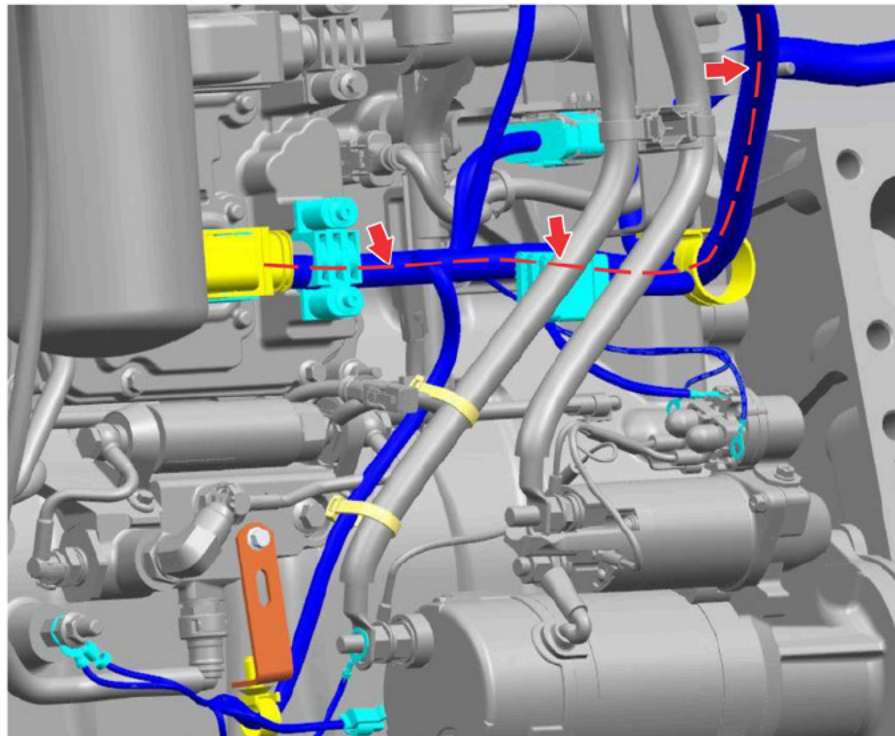

Fig. 38, Engine Overlay Routing Path (Cummins X12)





08/30/2024

f548611

Fig. 40, Engine Overlay Routing Path (Cummins X15)

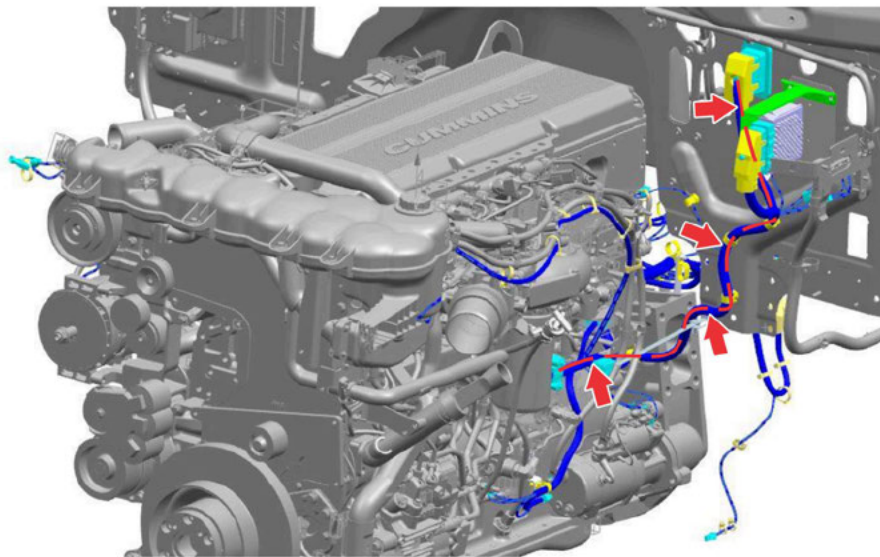

08/30/2024

f548612

Fig. 41, Engine Overlay Routing Path from ECM to Bulkhead Connector BHA (Cummins X15)

13. Connect the engine overlay to the bulkhead connector BHA.

a. Bulkhead connector BHA should already be disconnected from the earlier dash overlay installation. If not, disconnect it. See Fig. [42](#).

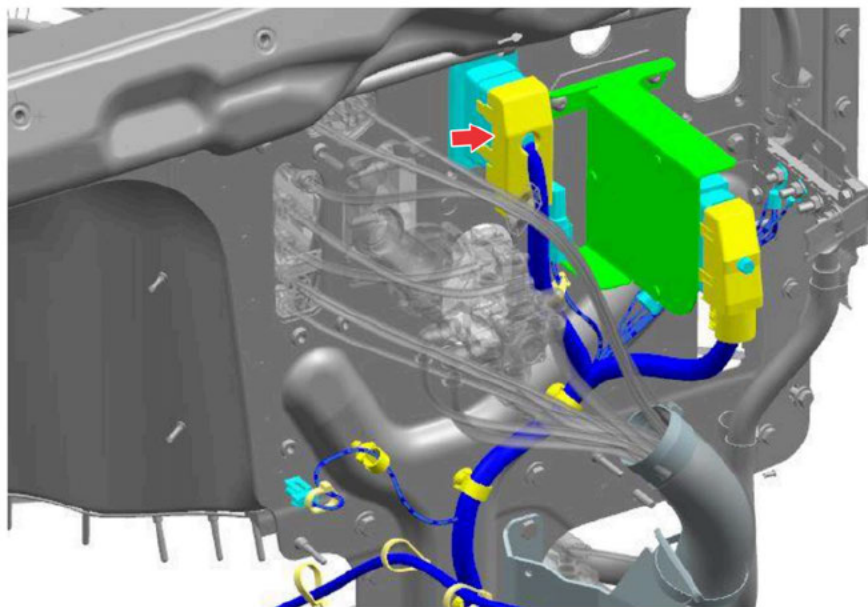
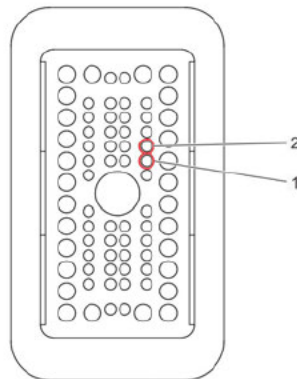

Fig. 42, Bulkhead Connector BHA

b. Remove the backshell and the terminal guide.

c. Locate the J1939 wires in bulkhead connector BHA cavities 55 and 56. See Fig. 43.



1. CAV 56 J1939+ (Y)

2. CAV 55 J1939- (DKG)

Fig. 43, Bulkhead Connector BHA J1939 Pinout Locations

d. Remove the J1939 wires from the bulkhead connector BHA cavities 55 and 56.

e. Cut the terminals off the existing J1939 wires removed in step 13.d and tape them back to the existing harness.

f. Insert the J1939 wires from engine overlay A66-37409-000 (Cummins X12) or A66-37415-000 (Cummins X15) into cavities 55 and 56 of the bulkhead connector BHA: J1939- (DKG) into cavity 55 and J1939+ (Y) into cavity 56. Make sure the terminals engage into the connector. See Fig. 43 and Fig. 44.

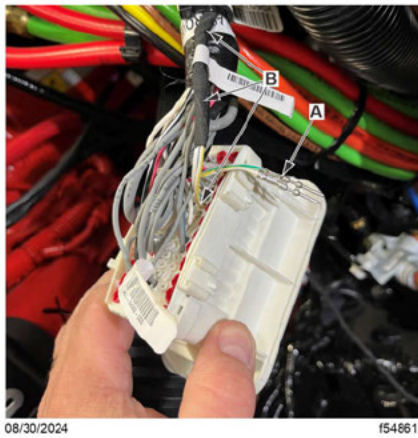

A. Cut the terminals and tape wires back
 B. Engine overlay installed at BHA on the harness.

Fig. 44, Installing Engine Overlay At Bulkhead Connector BHA

g. Install the terminal guide and backshell.

h. Connect the bulkhead connector BHA to the mating connector on the firewall.

14. Engine overlay Allison transmission ECU connection (**follow this step even if the vehicle is equipped with an Eaton Endurant transmission**):

a. Locate the Allison ECU connector along the engine overlay harness just below the bulkhead connector BHA.

b. If the vehicle has an Eaton Endurant transmission, proceed to step 14.c to install a cap at the Allison connector on the engine overlay. If the vehicle has an Allison transmission and Allison extension A66-37412-000 was called out in the vehicle specific parts list, skip to step 14.d.

c. Install the end cap at the 2-pin connector on the engine harness overlay labeled 'ALLISON TCU'. See note below. See Fig. 11, Fig. 10, Fig. 45, and Fig. 46. Secure to existing harnesses with zip ties as needed, then go to step 15.

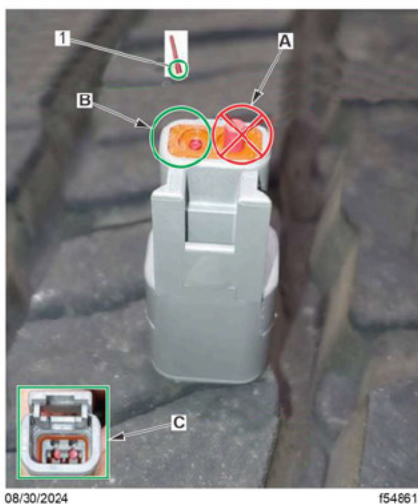

A. Incorrect cavity plug installation.
 B. Correct cavity plug installation.

C. Inside view of the connector with cavity plugs installed correctly.

1. The large end of the cavity plug is installed through the orange seal

Fig. 45, Correct and Incorrect Installation of Cavity Plugs When Making Up End Cap From Piece Parts



Fig. 46, End Cap Installed on Engine Harness Overlay Connector Labeled 'ALLISON TCU'

➤ **Note:** The Cap (23-13303-821) or can be made up of the following piece parts: (QTY 1) DUF DT04 2P cap and (QTY2) DUF 0413 204 2005 cavity plug. See Fig. [45](#) for cavity plug installation.

- d. Connect the Allison extension harness (A66-37412-000) to the engine overlay harness connector labeled 'ALLISON TCU' located in step 14.b and route the harness to the Allison ECM connector. See Fig. [47](#).

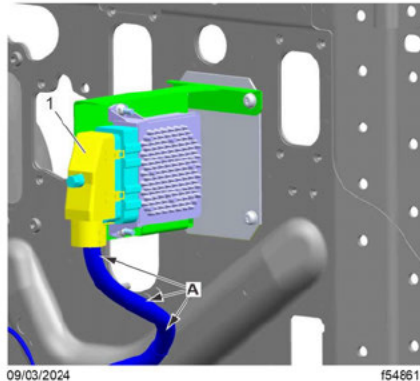

1. Allison ECM Connector
A. Routing path of Allison extension A66-37412-000 to Allison ECM on the firewall.

Fig. 47, Allison ECM and Routing Path of Allison Extension Harness

- e. Disconnect the Allison ECM connector from the ECM. See Fig. [47](#).

- f. Remove the backshell and slide it out of the way. See Fig. [48](#).

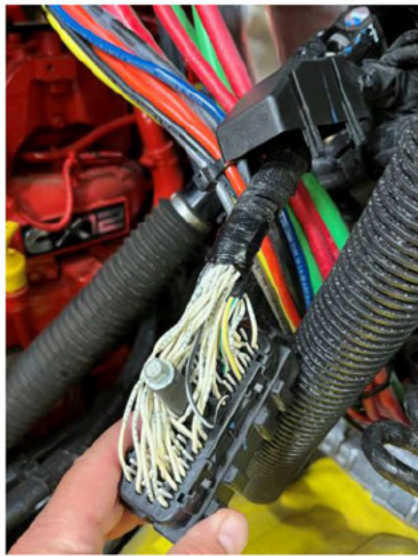

09/03/2024

f546619

Fig. 48, Allison ECU Connector Backshell Removed

- g. Remove the terminal guide by releasing the tabs on each side. See Fig. [49](#) and Fig. [50](#).



09/03/2024

f546620

Fig. 49, Removing Terminal Guide from Allison ECU Connector



09/03/2024

f546621

Fig. 50, Terminal Guide Removed From Allison ECU Connector

- h. Locate the J1939 wires in the Allison ECM connector cavities 6 and 27. See Fig. [51](#).

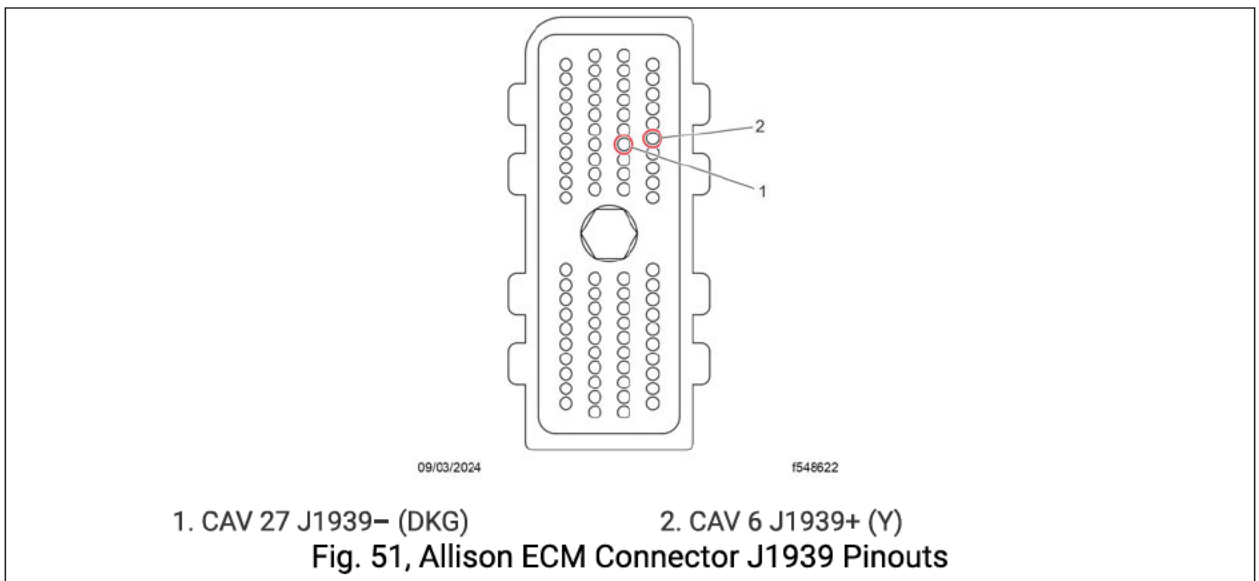

- i. Using the tool DK10CHA17002-2, remove the J1939 wires from the Allison ECM connector cavities 6 and 27 by carefully releasing the tangs locking the terminal in place. See Fig. 52 and Fig. 51.



- j. Cut the terminals off the existing J1939 wires removed in step 14.h and tape them back to the existing harness.
- k. Insert the J1939 wires from the Allison extension harness A66-37412-000 into cavities 6 and 27 of the Allison ECM connector: J1939+ (Y) into cavity 6 and J1939- (DKG) into cavity 27. Make sure the terminals engage into the connector. See Fig. 51.

- l. Install the terminal guide and backshell.

- m. Connect the Allison ECM connector.

- n. Secure the Allison extension harness to the existing harness using zip ties as needed.

- 15. eViscous fan connection (Cummins X15 only):

a. If the vehicle has a Cummins X15 with an E-Viscous fan, go to step 15.b. If the vehicle has an X12 engine, skip to step 16.

b. Locate the 4-pin connector labeled 'E-VISCOUS FAN' along the engine overlay harness A66-37415-000. It will be between the engine ECM and the bulkhead connector BHA. See Fig. [11](#) and [53](#).



1. Jumper (A66-37414-000) 3. Bulkhead Connector BHA
2. eViscous Fan Connector 4. Engine ECM
Fig. 53, Location of eViscous Fan Connector Along Engine Overlay Harness

c. If the vehicle is not equipped with an eViscous fan, and jumper A66-37414-000 was called out in the vehicle specific parts list, continue to step 15.d. Otherwise, skip to step 15.e.

d. Connect jumper A66-37414-000 to the connector labeled 'E-VISCOUS FAN' on the engine overlay located in step 15.b See Fig. [11](#), Fig. [53](#), and Fig. [54](#). Then proceed to step 16.



Fig. 54, Jumper A66-37414-000

e. If the vehicle is equipped with an eViscous fan and the EVIS-Fan extension A66-37416-000 is called out in the vehicle specific parts list, continue to step 15.f.

f. Connect the EVIS-Fan extension A66-37416-000 4-pin connector to the engine overlay harness connector labeled 'E-VISCOUS FAN'. See Fig. [11](#) and Fig. [53](#). Connect the extension in place of the jumper shown in Fig. [53](#).

g. Replace the existing engine fan harness that routes between the engine fan, engine fan controller, and the engine harness with new fan harness A66-39340-000. See Fig. [11](#) and Fig. [55](#).



1. Fan Harness Connection to eViscous Fan
 2. Fan Harness (A66-39340-000)
 3. Engine Harness Connection to Fan Harness
 4. Fan Controller Connector
Fig. 55, eViscous Fan Harness A66-39340-000 (Installation May Vary)

Note: E-Viscous fan harness installation may vary from what is shown in Fig. 55.

- h. Route the EVIS-Fan extension A66-37416-000 to the engine harness connector that connects to the fan harness A66-39340-000. The extension is routed up the left side of the engine and secured with zip ties as needed. See Fig. 56.

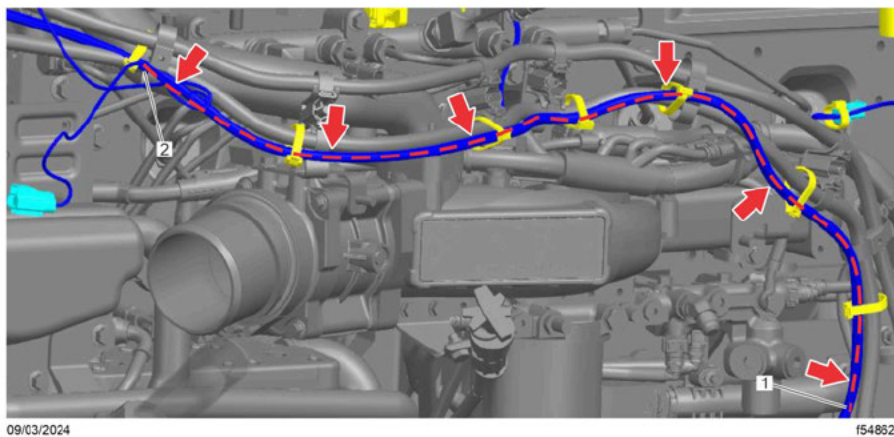

1. To connection with the engine overlay
 2. To connection engine harness fan harness connector
Fig. 56, Routing Path of EVIS-Fan Extension Harness A66-37416-000

- i. Disconnect the connector from the engine harness that connects to the fan harness A66-39340-000. See Fig. 57.

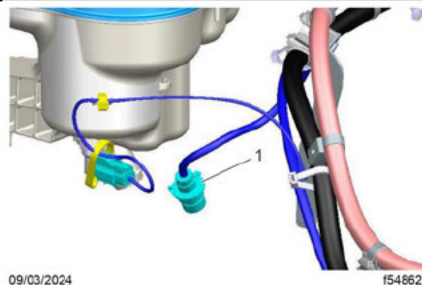

1. Fan Connector from the Engine Harness

Fig. 57, Fan Connector from Engine Harness – Upper Left Side of the Engine (Connects to Engine Fan Harness)

- j. On the engine harness side of the connector, locate the J1939 wires in cavities 1 and 2. See Fig. 58.

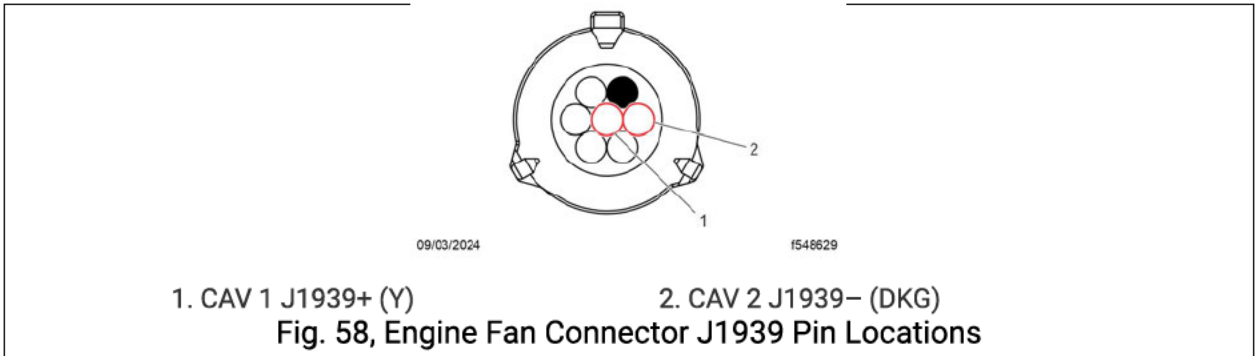

- k. Remove the J1939 wires from cavities 1 and 2 of the engine fan connector.
- l. Cut the terminals off the existing J1939 wires removed in step 15.k and tape them back to the existing harness.
- m. Insert the J1939 wires from the EVIS-Fan extension A66-37416-000 into cavities 1 and 2 of the engine fan connector: J1939+ (Y) into cavity 1, and J1939- (DKG) into cavity 2.
- n. Connect the engine fan connector from the engine harness to the fan harness A66-39340-000.
- o. Secure fan harness and the extension harness with zip ties as needed. See Fig. 55.

16. Connect the engine overlay to the Cummins ECM.

- a. Remove the fasteners on the harness clamp attached to the engine. Cut the three zip ties that fasten the clamp to the harness. See Fig. 59.

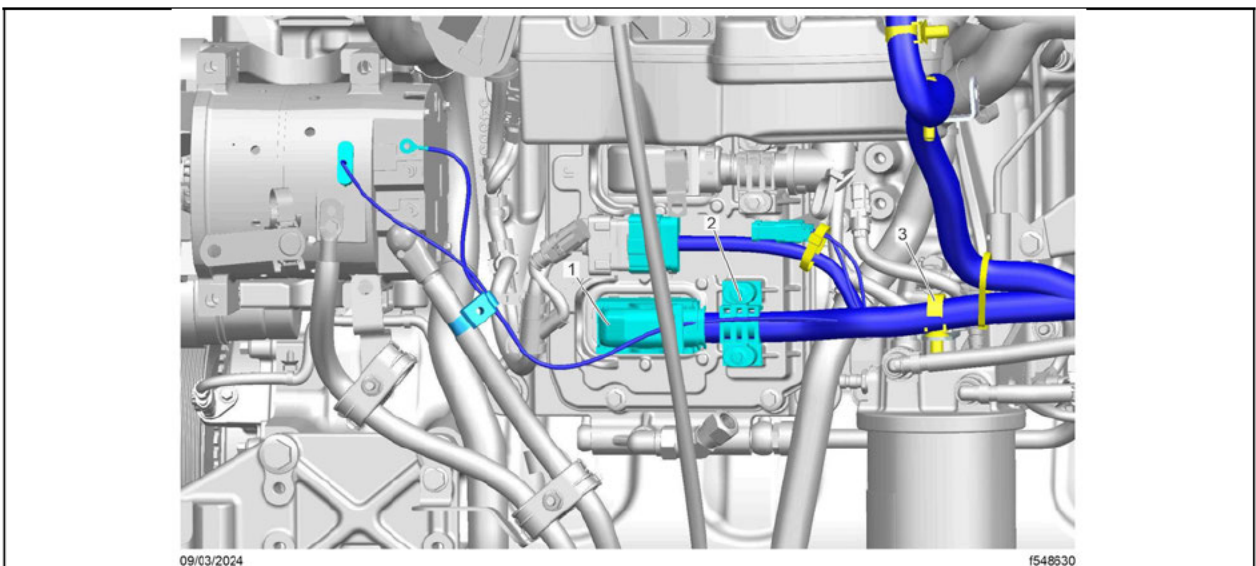

1. Cummins ECM Connector 2. Harness Clamp with Three Zip Ties Attached to the Engine 3. Harness Clamp Attached to the Bracket

Fig. 59, Cummins ECM Connector and Clamp Locations (Cummins X12 is Shown, X15 is Similar)

- b. Remove the other harness clamp that is further back from the bracket it attaches to. See Fig. [59](#).
- c. Unlatch and remove the electrical connector from the Cummins ECM as shown in Fig. [59](#).
- d. Remove the back cover from the Cummins ECM connector by disengaging the tangs as shown in Fig. [60](#).



Fig. 60, Cummins ECM Connector Back Cover Removal, Disengaging the Tangs

- e. Remove the terminal lock as shown in Fig. [61](#).

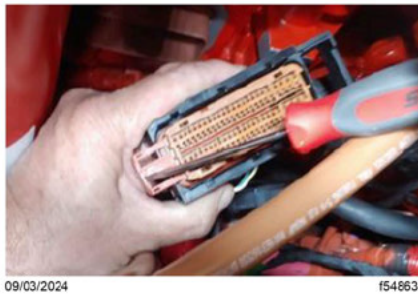
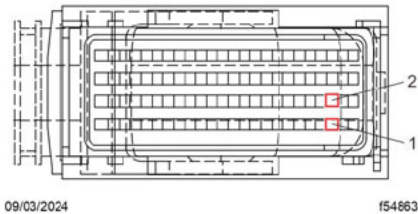

Fig. 61, Cummins ECM Connector Terminal Lock Removal

- f. Locate the J1939 wires in the Cummins ECM connector cavities 22 and 46. See Fig. [62](#).



1. CAV 22 J1939+ (Y)

2. CAV 46 J1939- (DKG)

Fig. 62, Cummins ECM Connector J1939 Pin Locations

- g. Using terminal removal tool DK10CHA17002-14 or a similar tool, remove the J1939 wires from the Cummins ECM connector cavities 22 and 46. See Fig. [63](#).



09/03/2024

f546634

Fig. 63, Releasing and Removing J1939 Wires from the Cummins ECM Connector Using Terminal Tool DK10CHA17002-14

- h. Cut the terminals off the existing J1939 wires removed in step 16.g and tape them back to the existing harness.
 - i. Insert the J1939 wires from the engine overlay harness (A66-37409-000 or A66-37415-000) into cavities 22 and 46 of the Cummins ECM connector: J1939+ (Y) into cavity 22 and J1939- (DKG) into cavity 46. Make sure the terminals engage into the connector. See Fig. [10](#), Fig. [11](#), and Fig. [62](#).
 - j. Install the terminal lock and backshell.
 - k. Attach the harness clamp to the harness using three zip ties. Leave the zip ties loose so the clamp can be positioned into the correct location. See Fig. [59](#).
 - l. Plug the Cummins ECM connector into the ECM by engaging the latch.
 - m. Position the harness clamp along the harness so the fasteners line up with the holes in the engine block. Install the fasteners and tighten. See Fig. [59](#).
 - n. Tighten the zip ties installed in step 16.k and cut off the excess. See Fig. [59](#).
 - o. Install the other harness clamp on the bracket. See Fig. [59](#).
 - p. Secure the engine overlay leading to the Cummins ECM with zip ties as needed.
17. Connect the engine overlay to Eaton Endurant transmission.
- a. If the vehicle has an Eaton Endurant transmission, go to step 17.c.
 - b. If the vehicle has an Allison transmission, install jumper A66-37414-000 onto the 4-pin connector on the engine overlay harness labeled 'EATON TRANS'. See Fig. [10](#) and [11](#). Secure the wiring with zip ties as needed, then go to step 18.

c. Connect the Eaton Endurant transmission extension harness A66-37413-000 to the engine overlay harness connector labeled 'EATON TRANS'. See Fig. 10 and 11.

d. Route the Endurant extension to the Eaton Endurant transmission ECU along the path shown in Fig. 64.

Note: It may be necessary to disconnect the driveline from the transmission and move it out of the way to gain access to the Endurant transmission ECU connectors and wiring.

e. Remove the red tie securing the driver's side connector latch as shown in Fig. 65.

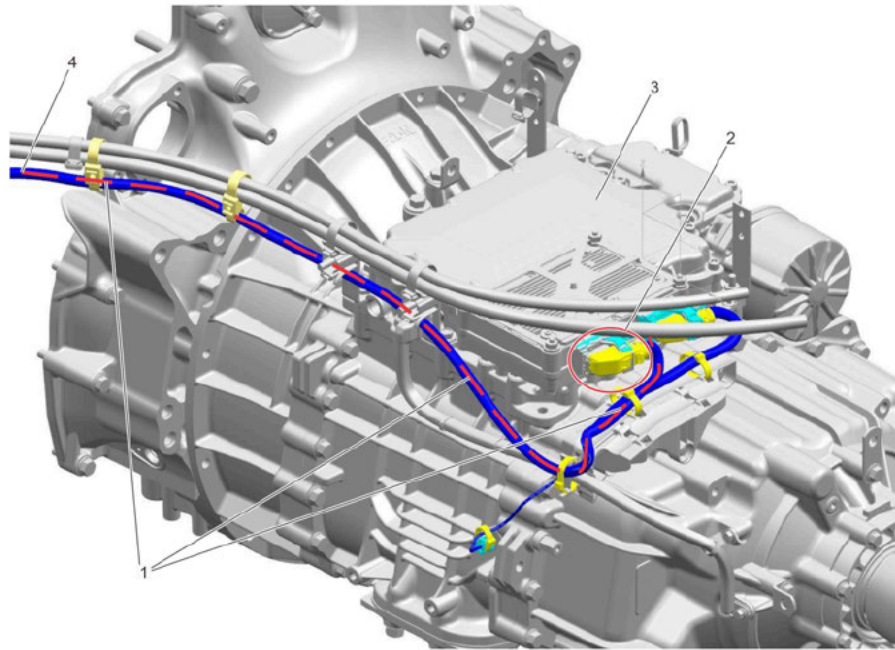

- | | |
|---|--|
| 1. Routing Path of Endurant Extension Harness | 3. Eaton Endurant ECU |
| 2. Driver Side Connector | 4. Approximate Location of Endurant Extension Connection to Engine Overlay |

Fig. 64, Routing Path of Eaton Endurant Extension Harness (Cummins X12 Shown, X15 is Similar)

f. Unlatch and remove the connector from the Endurant transmission ECU. See Fig. 65.

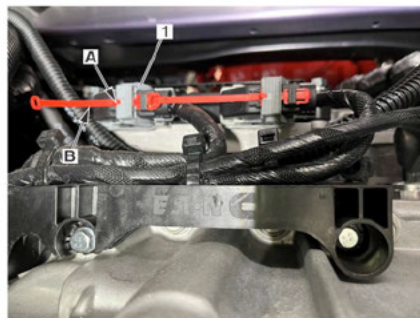

- | | |
|---|---|
| 1. Connector | |
| A. Press here to unlatch the connector. | B. Remove this tie that prevents the connector from unlatching. |

Fig. 65, Unlatching the Eaton Endurant ECU Connector

- g. Cut zip ties as needed to get enough slack in the harness to work with the connector removed in step 17.f.
- h. Remove the backshell from the connector. See Fig. [66](#).

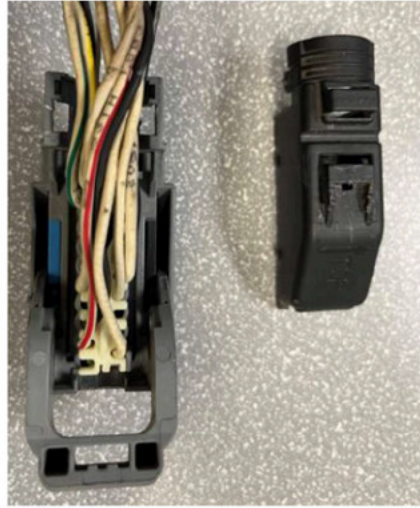

09/03/2024

1546637

Fig. 66, Removing Backshell from Eaton Endurant Connector

- i. Remove the terminal guide and terminal retention pieces from the connector. See Fig. [67](#) and Fig. [68](#).



09/03/2024

1546638



Fig. 68, Removing the Terminal Retention Clip from the Eaton Endurant Connector

- j. Carefully remove a few inches of the harness wrap to access the wires leading to the connector.

- k. Locate the J1939 wires in the Endurant connector cavities 11 and 12. See Fig. 69.

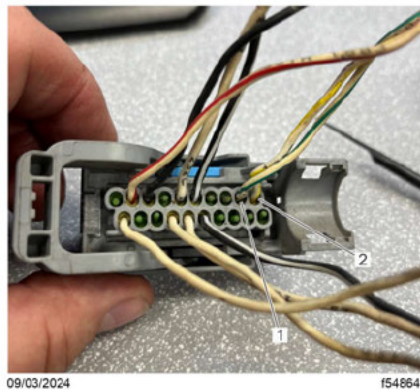

1. CAV 12 J1939- (DKG)

2. CAV 11 J1939+ (Y)

Fig. 69, Eaton Endurant ECU Connector J1939 Pin Locations

- l. Remove the J1939 wires from the connector cavities 11 and 12 using a terminal removal tool such as DK10CHA17002-1 to release the terminal tangs.

- m. Cut the terminals off the existing J1939 wires removed in step 17.l and tape them back to the existing harness.

- n. Insert the J1939 wires from the Endurant extension harness A66-37413-000 into cavities 11 and 12 of the driver side Endurant ECM connector: J1939+ (Y) into cavity 11 and J1939- (DKG) into cavity 12. Make sure the terminals engage into the connector. See Fig. 69.

- o. Install the harness wrap and tape as needed.

- p. Install the connector terminal guide, terminal retention clip, and backshell. See Fig. 66, Fig. 67, and Fig. 68.

q. Insert the connector into the Endurant ECM and latch it into place.

r. Secure the latch with the red tie removed in step 17.e.

s. Replace any zip ties removed in step 17.g.

t. Secure the Endurant extension harness along the routing path with zip ties as needed.

18. Route the chassis overlay harness.

a. Connect the chassis overlay harness A66-37417-000 connector labeled 'CONNECTION TO ENGINE OVERLAY' to the engine harness overlay connector labeled 'CONNECTION TO CHASSIS OVERLAY'. Refer to Fig. 10, Fig. 11, and Fig. 12.

b. Route the chassis overlay harness A66-37417-000 from the connection to the engine overlay along existing harnesses along the left hand frame rail, then to the right frame rail over the 561 crossmember. Route along existing harnesses. See Fig. 70, Fig. 71, and Fig. 72.

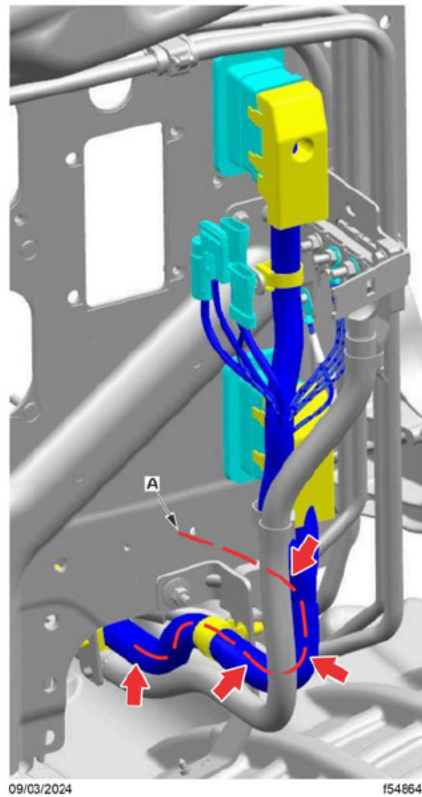

A. Connect to the engine overlay.

Fig. 70, Chassis Overlay Harness Routing Engine/Firewall Area

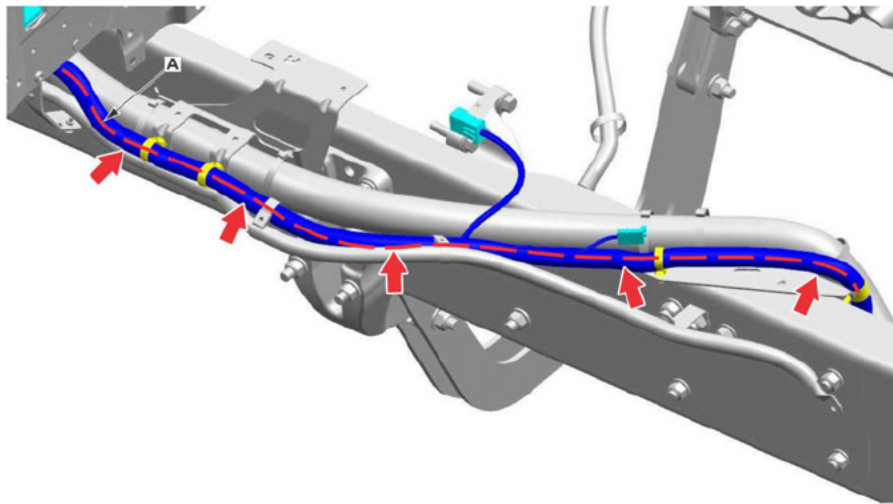

A. To connection with the engine overlay.

Fig. 71, Chassis Overlay Harness Routing Along Left Frame Rail

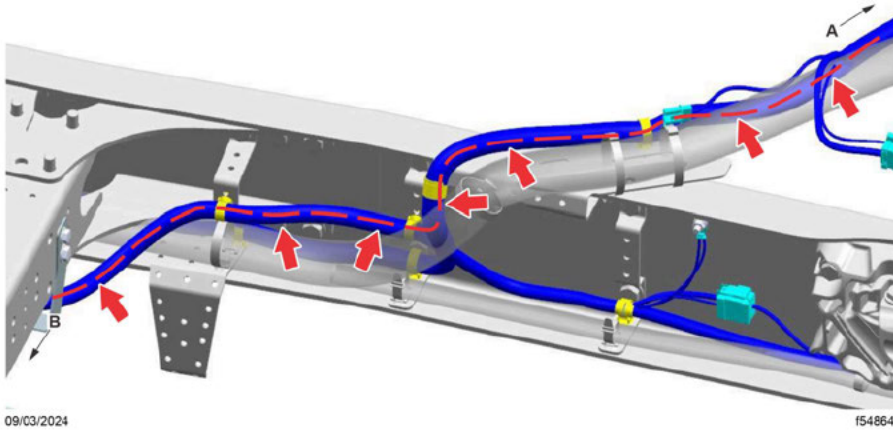

A. To connection with the engine overlay. B. Route across the framerrail along the existing harness.

Fig. 72, Chassis Overlay Harness Routing Along Left Frame Rail, Crossing Over to Right Frame Rail

c. Secure the chassis overlay harness to existing harnesses along the routing path with zip ties as needed.

19. Connection of adaptive cruise control (ACC) extension harness or jumper.

a. If the vehicle specific parts list calls out extension harness A66-37418-000, skip to step 19.c. If not, go to step 19.b.

b. Install the jumper A66-37414-000 at the 4-pin connector on the chassis harness overlay labeled 'WABCO RADAR'. See Fig. 12. Secure to existing harnesses with zip ties as needed, then go to step 20.

c. Connect the adaptive cruise control (ACC) extension harness A66-37418-000 to the chassis overlay harness connector labeled 'WABCO RADAR'. See Fig. 12 and Fig. 73.

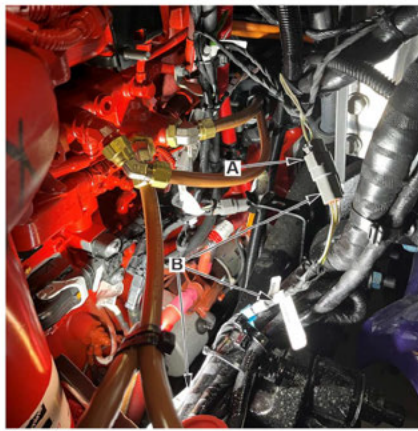

09/03/2024

f548644

A. Chassis overlay harness connector B. ACC extension harness A66-37418-000.
 labled 'WABCO RADAR'.

Fig. 73, ACC Extension Harness A66-37418-000 Connection to Chassis Overlay Harness

- d. Route the ACC extension harness A66-37418-000 as show in Fig. 74, Fig. 75, and Fig. 76. Secure with zip ties as needed.

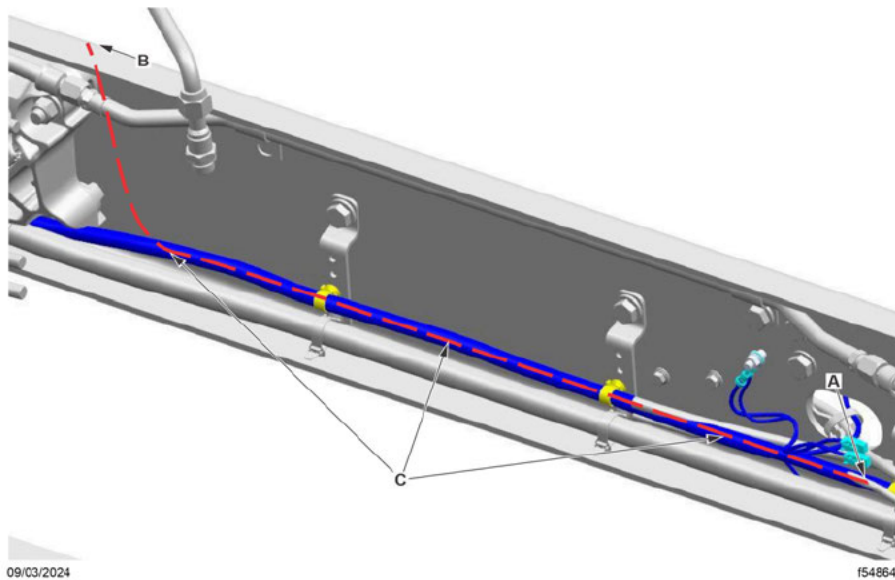

09/03/2024

f548645

A. To forward radar connector (bumper). C. Route extension harness A66-37418-000 along the existing harness.
 B. To chassis overlay harness connection labled 'WABCO RADAR'.

Fig. 74, Routing Path of ACC Extension Harness A66-37418-000 Along Left Frame Rail

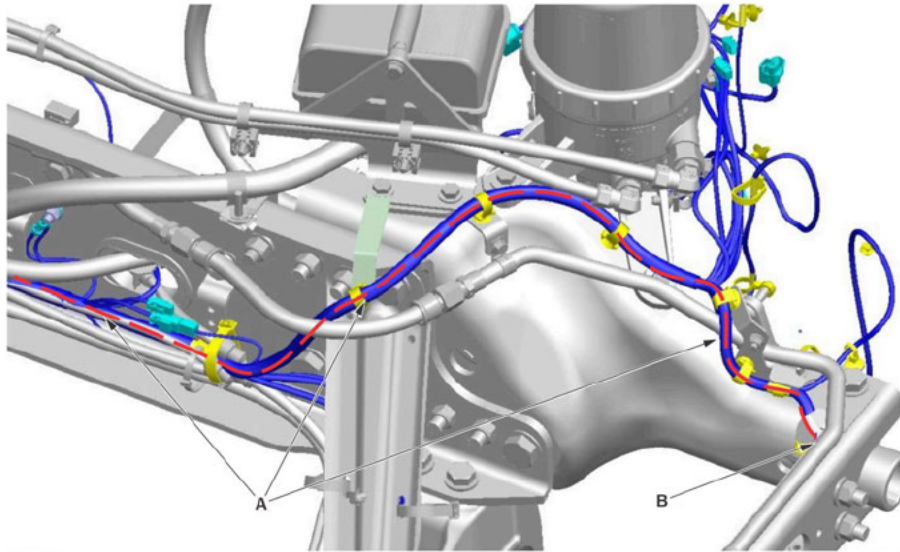

09/03/2024

f548646

- A. Route extension harness A66-37418-B. To forward radar connector.
- 000 along existing harness.

Fig. 75, Routing Path of ACC Extension Harness A66-37418-000 Toward Forward Radar

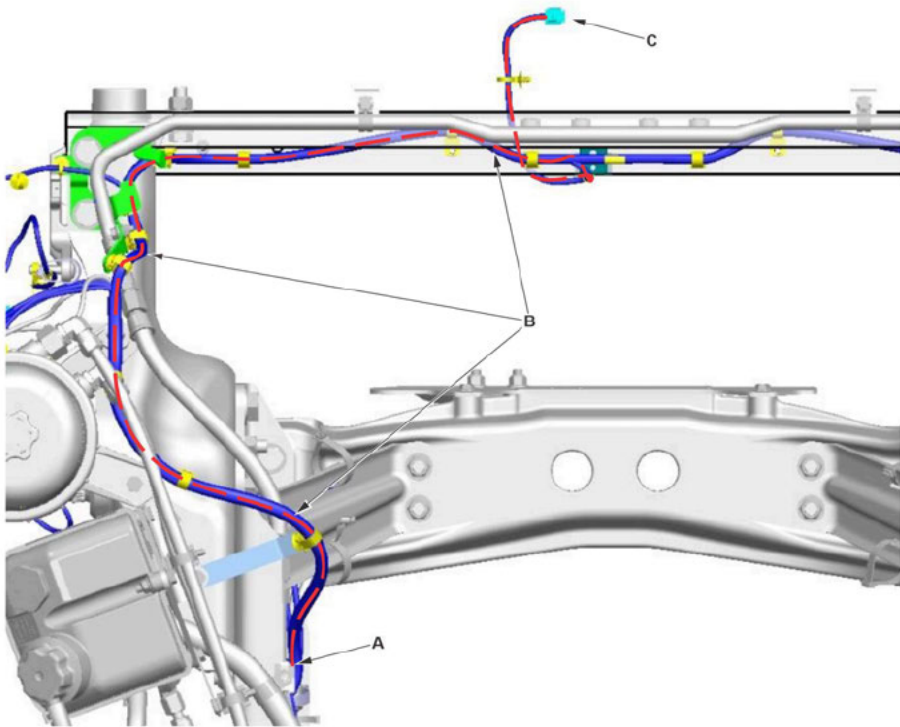

09/03/2024

f548647

- A. From connection to chassis overlay harness.
- C. Forward radar connector.
- B. Route extension harness A66-37418-000 along existing harness (plan view).

Fig. 76, Routing Path of ACC Extension Harness A66-37418-000 Toward Forward Radar (plan view)

e. Disconnect the forward radar connector.

- f. Untape the rubber boot from the connector and slide it back on the harness out of the way.

- g. Unlatch the outer shell of the connector as shown in Fig. 77 and slide it back on the harness out of the way.

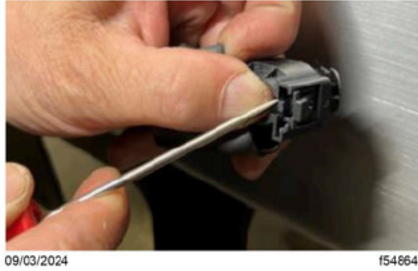

Fig. 77, Removing Outer Shell From Forward Radar Connector

- h. Remove the green terminal retention locks from the connector as shown in Fig. 78.



Fig. 78, Removing the Green Terminal Retention Locks from the Forward Radar Connector

- i. Locate the J1939 wires in forward radar connector cavities 3 and 6. See Fig. 79.

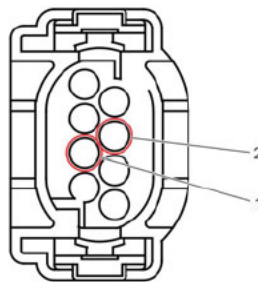

1. CAV 6 J1939- (DKG)

2. CAV 3 J1939+ (Y)

Fig. 79, Forward Radar Connector J1939 Pin Locations

- j. Remove the J1939 wires from the connector cavities 3 and 6 using a terminal removal tool such as DK10CHA17002-1 to release the terminal tangs as shown in Fig. 80.



09/03/2024

f546651

Fig. 80, Removing Wires from Forward Radar Connector Using Terminal Tool DK10CHA17002-1 to Release Terminal Tangs.

- k. Cut the terminals off the existing J1939 wires removed in step 19.j and tape them back to the existing harness.
- l. Insert the J1939 wires from the forward radar extension harness A66-37418-000 into cavities 3 and 6 of the forward radar connector: J1939+ (Y) into cavity 3 and J1939- (DKG) into cavity 6. Make sure the terminals engage into the connector. See Fig. [79](#).
- m. Install the green terminal retention locks as shown in Fig. [81](#).



09/03/2024

f546652

Fig. 81, Installing the Green Terminal Retention Locks on the Forward Radar Connector

- n. Install the outer shell onto the connector. See Fig. [82](#).



09/03/2024

f546653

1. Outer Shell

Fig. 82, Outer Shell Installed Onto the Forward Radar Connector

- o. Slide the rubber boot over the outer shell of the forward radar connector.
- p. Tape the boot to the harness.

- q. Connect the forward radar connector to the forward radar. See Fig. [83](#).



Fig. 83, Forward Radar Connector Connected to Forward Radar

- r. Secure the forward radar extension harness A66-37418-000 to the existing harness along routing path with zip ties as needed.

20. Connection of the tire pressure monitoring system (TPMS) extension harness or Jumper.

- a. If the vehicle specific parts list calls out TPMS extension harness A66-37419-000 or A66-37420-000, skip to step 20.c. If not, go to step 20.b.

- b. Install jumper A66-37414-000 at the 4-pin connector on the chassis harness overlay labeled 'TPMS.' Secure to existing harnesses with zip ties as needed, then go to step 21.

- c. Connect the TPMS extension harness A66-37419-000 or A66-37420-000 to the chassis overlay harness connector labeled 'TPMS.' See Fig. [12](#) and Fig. [84](#).

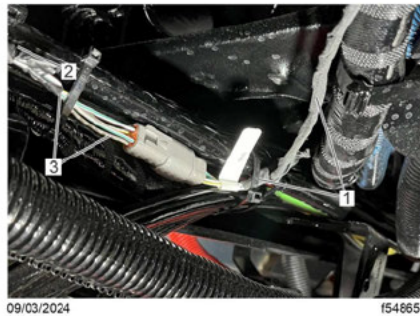

1. Chassis Overlay Harness
2. To TPMS
3. TPMS Extension Harness (A06-37491-000 or A06-37420-000)
Fig. 84, Connection of TPMS Extension Harness to Chassis Overlay Harness

- d. Route the TPMS extension harness as shown in Fig. [85](#). Secure with zip ties as needed.

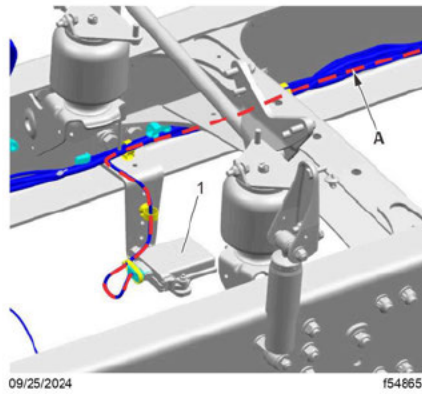

A. TPMS Extension Routing.

1. TPMS Module

Fig. 85, Typical TPMS Extension Harness Routing

e. Disconnect the TPMS connector from the TPMS ECU.

f. Untape the rubber boot from the TPMS connector and slide it back on the harness out of the way.

g. Remove the orange terminal retention lock from the connector as shown in Fig. [86](#) and Fig. [87](#).

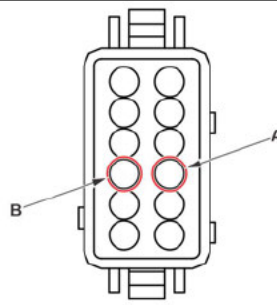

Fig. 86, TPMS Connector With Rubber Boot Slid Back Away From The Connector



Fig. 87, TPMS Connector With Orange Terminal Retention Lock Removed

h. Locate the J1939 wires in TPMS connector cavities 4 and 9. See Fig. [88](#).



09/03/2024

1548659

A. CAV 4 J1939+ (Y)

B. CAV 9 J1939- (DKG)

Fig. 88, TPMS Connector J1939 Pin Locations

- i. Remove the J1939 wires from the connector cavities 4 and 9 using a terminal removal tool such as DK10CHA17002-2 to release the terminal tangs as shown in Fig. 89.



09/03/2024

1548660

Fig. 89, Removing J1939 Wires from TPMS Connector Using Terminal Removal Tool (DK10CHA17002-2)

- j. Cut the terminals off the existing J1939 wires removed in step 20.i and tape them back to the existing harness.

- k. Insert the J1939 wires from the TPMS extension harness A66-37419-000 or A66-37420-000 into cavities 4 and 9 of the TPMS connector: J1939+ (Y) into cavity 4 and J1939- (DKG) into cavity 9. Make sure the terminals engage into the connector. See Fig. 12 and Fig. 88.

- l. Install the orange terminal retention lock on the TPMS connector. See Fig. 86 and Fig. 87.

- m. Slide the rubber boot into position over the TPMS connector.

- n. Tape the rubber boot to the harness.

- o. Connect the TPMS connector to the TPMS ECU.

- p. Secure the TPMS extension harness with zip ties as needed.

21. Connection of the side obstacle detection (SODS) add on harness or end cap.

- a. If the vehicle specific parts list calls out SODS add on harness A66-37421-000, skip to step 21.c. If not, go to step 21.b.

- b. Install the end cap at the 2-pin connector on the chassis harness overlay labeled 'BENDIX RADAR'. See note below. See Fig. 12. Also, refer to Fig. 45 if making end cap with piece parts. Secure to existing harnesses with zip ties as needed, then go to step 22.

👉 **Note:** Cap is P/N 23-13303-821 or can be made up of the following piece parts: (QTY 1) DUF DT04 2P and (QTY2) DUF 0413 204 2005.

c. Connect SODS add on harness A66-37421-000 to chassis harness overlay connector labeled 'BENDIX RADAR'.

d. Route the SODS add on harness to the side radar as shown in Fig. 90.

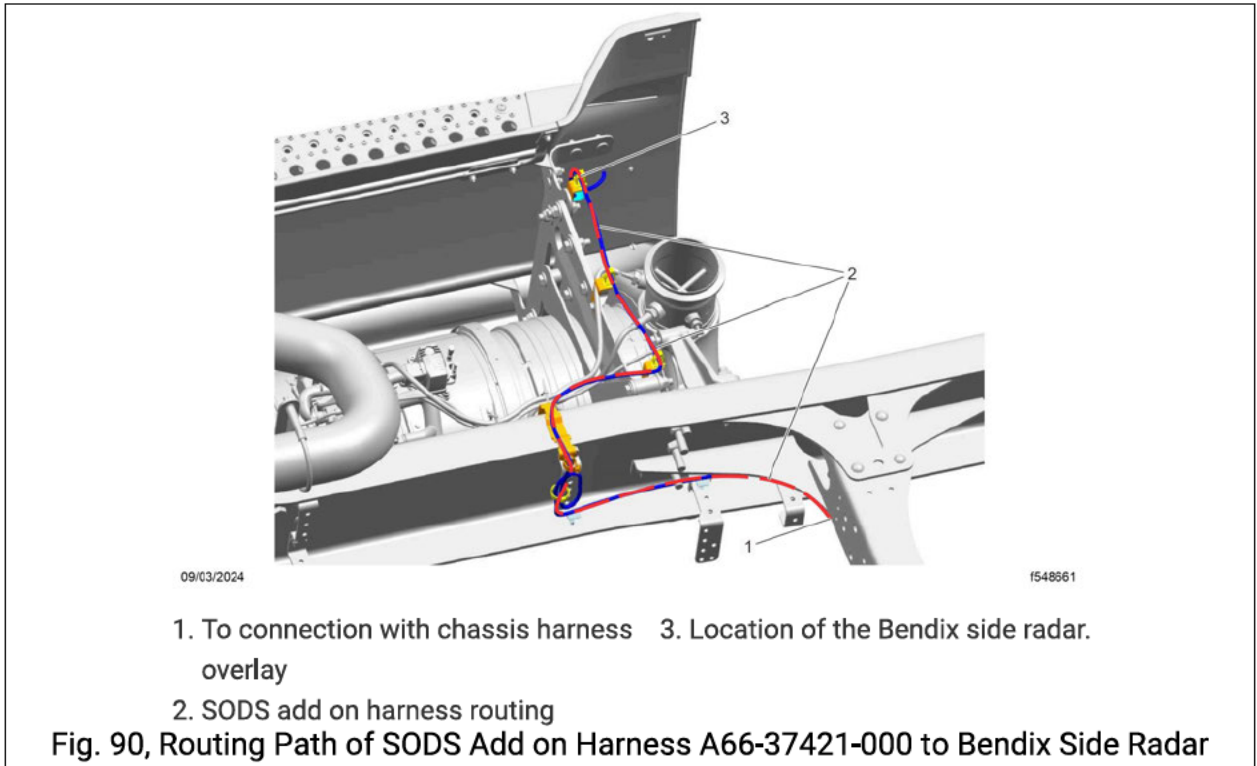

👉 **Note:** It may be necessary to remove side fairing, to gain access to the Bendix side radar and extension harness routing path, depending on vehicle configuration.

e. The Bendix side radar has two pigtails, one with a 6-pin connector, the other with a 2-pin connector. Disconnect the 2-pin connector from the existing chassis harness. See Fig. 91.

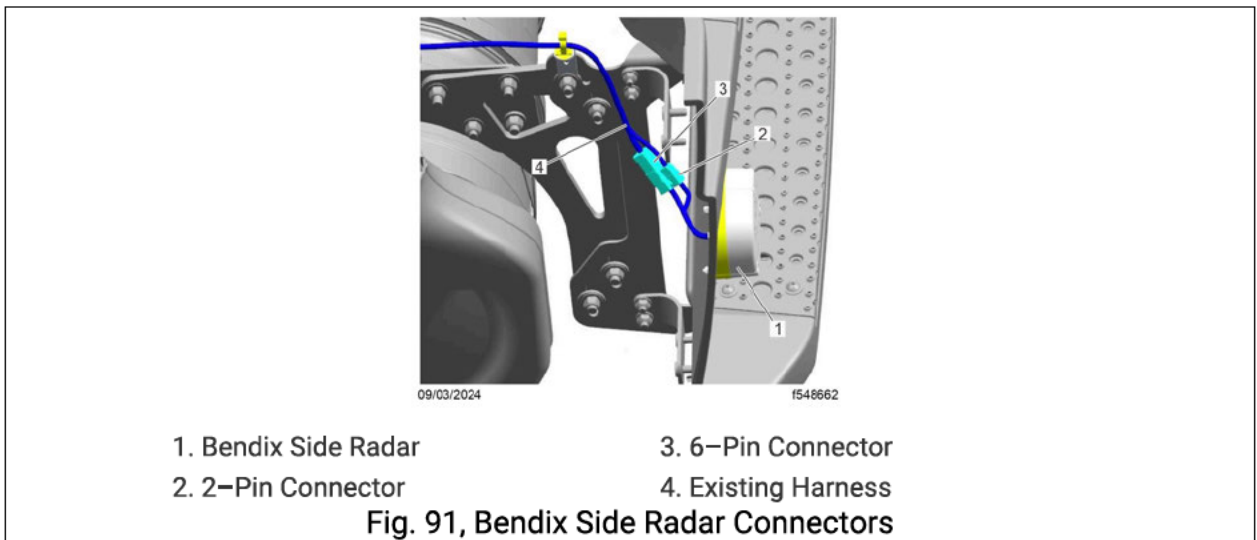

Note: Connector may already be disconnected if interim repair was previously made – disconnecting side radar to help eliminate datalink errors.

- f. Cut the 2-pin connector off the existing chassis harness that connects to the side radar. Do not cut the end leading to the Bendix side radar sensor. See Fig. [92](#).



- g. Tape the wires that were cut in step 21.f back onto the harness.

- h. If the existing harness leading to the Bendix side radar was wrapped in heat protective tape near the ATD, wrap the add on harness with the same heat protective tape where it routes along the existing harness in the same area. See Fig. [93](#).

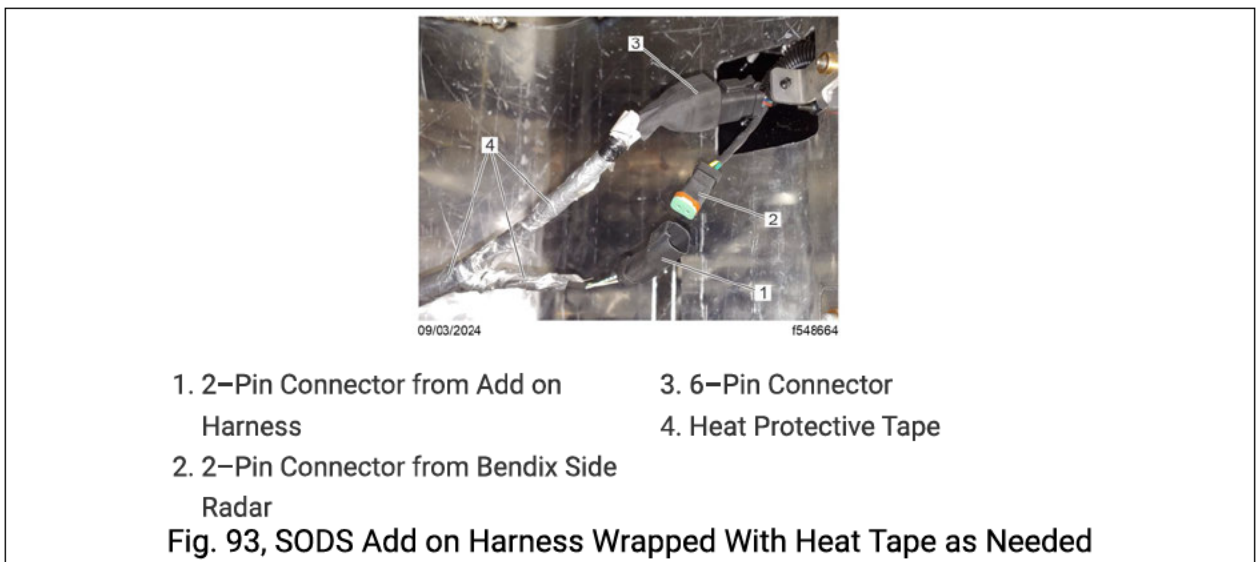

- i. Connect the 2-pin connector from the SODS add on harness to the 2-pin connector from the Bendix side radar. See Fig. [93](#).

- j. Secure the SODS add on harness to the existing harness using zip ties as needed.

k. If previously removed for access, install side fairing and/or any other components removed.

22. Follow the substeps below for Optimax extension installation.

a. If the vehicle specific parts list calls out extension harness A66-37422-000, skip to step 22.c. If not, go to step 22.b.

b. Install the terminating resistor 23-13303-902 in the chassis harness overlay connector labeled 'EOL RESISTOR', then go to step 23.

c. Connect the Optimax extension harness A66-37422-000 to the chassis overlay harness connector labeled 'EOL RESISTOR'. See Fig. [12](#).

Note: If the vehicle has a Hadley Smart Valve instead of Hendrickson Optimax, utilize the instructions that follow, only route the Optimax extension harness to the Hadley smart valve and make connection per the note in [12](#).

d. Route the Optimax extension harness A66-37422-000 as show in Fig. [94](#) and Fig. [95](#). Secure with zip ties as needed.

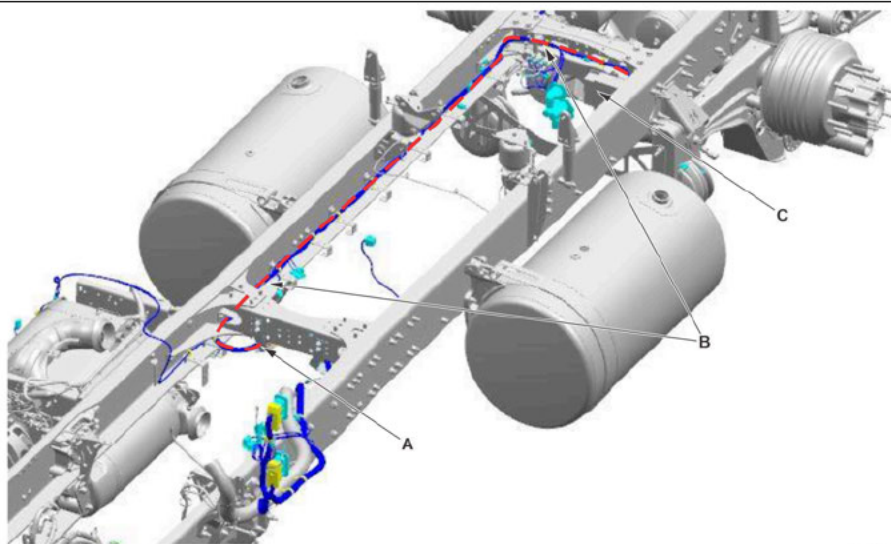

09/25/2024

f548665

A. Connect Optimax extension to chassis overlay connector labeled 'EOL Resistor'.

B. Optimax extension harness routing.

Fig. 94, Routing Optimax Extension Harness A66-37422-000

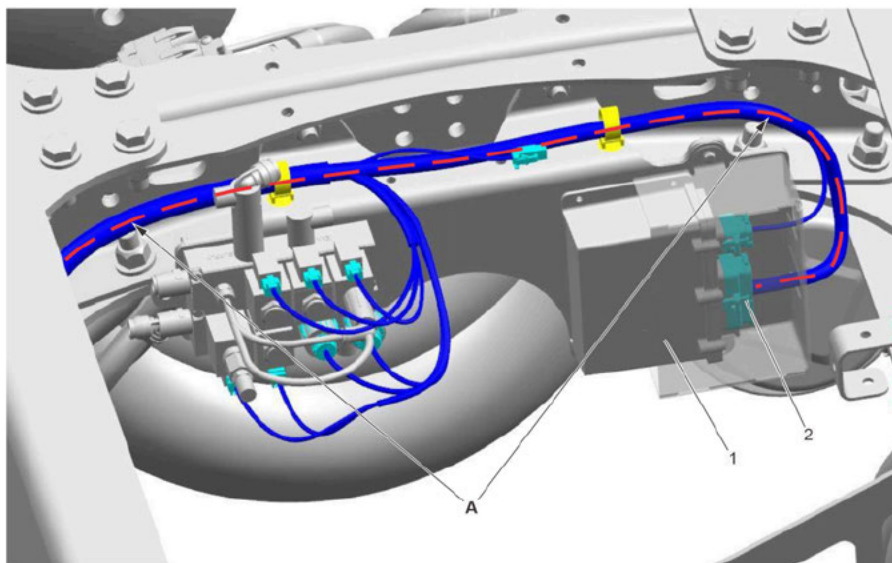

A. Routing of Optimax extension harness to Optimax ECU.

1. Optimax ECU

2. 35-Pin Connector

Fig. 95, Routing Optimax Extension Harness A66-37422-000 to Optimax ECU

e. Disconnect the 35-pin connector from the Optimax ECU.

f. Locate the J1939 wires in the Optimax 35-pin connector cavities 34 and 35. See Fig. 96.

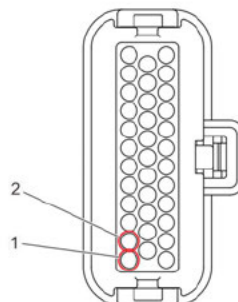

1. CAV 35 J1939+ (Y)

2. CAV 34 J1939- (DKG)

Fig. 96, Optimax 35-Pin Connector J1939 Pin Locations

g. Remove the J1939 wires from the Optimax 35-pin connector cavities 34 and 35.

h. Cut the terminals off the existing J1939 wires removed in step 20.g and tape them back to the existing harness.

i. Insert the J1939 wires from the Optimax extension harness A66-37422-000 into cavities 34 and 35 of the Optimax 35-pin connector: J1939- (DKG) into cavity 34 and J1939+ (Y) into cavity 35. Make sure the terminals engage into the connector. See Fig. 96.

j. If the harness wrap was removed to access wiring in the previous steps, retape as needed.

k. Connect the 35-pin Optimax connector to the Optimax ECU.

l. Secure the Optimax extension harness with zip ties as needed.

m. Connect terminating resistor 23-13303-902 to the open connector of the Optimax extension near the Optimax ECU. See Fig. 12.

23. Connect Diagnosticlink to the vehicle and check that all the ECUs are communicating on J1939, and that no J1939 faults are active. If all ECUs are communicating and no faults are present, proceed to step 24, otherwise troubleshoot and repair any issues as needed.

24. Install the dash panels and any other components removed during the installation.

25. Check for a dash sticker indicating the side radar is disconnected, and if present, remove it.

Warranty

This procedure is warrantable only if the described condition exists and the repair is performed within the applicable base or extended coverage warranty period. If a failure is not found, this procedure is considered preventive and warranty does not apply.

See Table 3 for OWL VMRS codes and labor allowance information. Enter this service bulletin number in the Service Bulletin # field.

Table 3, OWL VMRS Codes and Labor Allowance

Primary Failed Part	Component Code	Cause Code	Correction Code	SRT Code	Description	Hours
25-SB054-366	034-004 265	W3	57	160-5000A	HARNESSES, J1939 DATALINK, OVERLAY	6

Table 3, OWL VMRS Codes and Labor Allowance

Note:

F16

F26

F35

F36

034-004 265

TROUBLESHOOT

INSTALL

REMOVE

Document Number:0000135315