

January 2024
SF679 A-E
(Revised October 2024)

Subject: Virtual Technician Module

Models Affected: Specific model years 2023-2024 Freightliner 108SD, 114SD, 122SD, Business Class M2, and Coronado; Western Star 4700, 4900, and 6900, vehicles manufactured from March 9, 2022, through October 11, 2023.

General Information

Daimler Truck North America LLC (DTNA), on behalf of its Freightliner Trucks Division, and wholly owned subsidiary, Western Star Truck Sales, Inc., is initiating Field Service Campaign SF679 to modify the vehicles mentioned above.

REVISION:The parts table has been updated. The Hook and Loop tape part numbers listed in the parts table are intended for production purposes only and are not available for ordering from DTNA Parts Distribution Centers (PDCs). The Hook and Loop tape should be sourced locally.

2nd REVISION:Certain vehicles in Group B with Cummins engines have been reassigned to the newly created Group E. The Parts table has been updated to include the mounting bracket and fasteners required for Virtual Technician installation. A new SRT has been added to Campaign Group E: 996-F175E ECU, VIRTUAL TECHNICIAN, POPULATION E, INSTALL (SF679), 0.8 hours. Additionally, the Work Instructions have been revised to provide supplementary details for installing the Virtual Technician on vehicles with Cummins engines that were missing the Common Powertrain Controller (CPC) mounting bracket.

Certain vehicles spec'd with a Virtual Technician module (VT), were shipped without the VT module due to a parts shortages.

The VT module will be installed.

There are approximately 10,783 vehicles involved in this campaign.

Additional Repairs

Dealers must complete all outstanding recall and field service campaigns prior to the sale or delivery of a vehicle. A dealer will be liable for any progressive damage that results from its failure to complete campaigns before sale or delivery of a vehicle.

Owners may be liable for any progressive damage that results from failure to complete campaigns within a reasonable time after receiving notification.

Please contact Warranty Campaigns for consideration of additional charges prior to performing the repair.

Work Instructions

Please refer to the attached work instructions. Prior to performing the campaign, check the vehicle for a completion sticker (Form WAR261).

Replacement Parts

REVISION:The parts table has been updated. The Hook and Loop tape part numbers listed in the parts table are intended for production purposes only and are not available for ordering from DTNA Parts Distribution Centers (PDCs). The Hook and Loop tape should be sourced locally.

Replacement parts are now available and can be obtained by ordering the part number listed below from your facing Parts Distribution Center (PDC).

If our records show your dealership has ordered any vehicle(s) involved in campaign number SF679, a list of the customers and vehicle identification numbers will be available on the DTNA Portal. Please refer to this list when ordering parts for this campaign.

Table 1 - Replacement Parts for SF679

January 2024
SF679 A-E
(Revised October 2024)

| Campaign Number | Part Type | Kit Description | Kit Number | Qty |
|-----------------|-----------|-----------------------------------|-----------------|------|
| SF679 A | STANDARD | KIT - SERVICE – VIRTUAL TECH | 25-SF679-000 | 1 ea |
| | STANDARD | Zip Tie | 23-09796-629 | 1 ea |
| | OTHER | Hook and Loop tape 1 in width | Other part type | 1 FT |
| SF679 B | STANDARD | KIT - SERVICE – VIRTUAL TECH | 25-SF679-000 | 1 ea |
| | STANDARD | Zip Tie | 23-09796-629 | 2 ea |
| | OTHER | Hook and Loop tape 1 in width | Other part type | 1 FT |
| SF679 C | STANDARD | KIT - SERVICE – VIRTUAL TECH | 25-SF679-000 | 1 ea |
| SF679 D | STANDARD | KIT - SERVICE – VIRTUAL TECH | 25-SF679-000 | 1 ea |
| | OTHER | Hook and Loop tape 1 in width | Other part type | 1 FT |
| SF679 E | STANDARD | KIT - SERVICE – VIRTUAL TECH | 25-SF679-000 | 1 ea |
| | STANDARD | BRACKET-MOUNTING,CPC,WING DASH,M2 | 06-83277-000 | 1 ea |
| | STANDARD | SCREW-PHIT,THDRLG,PLASTITE#10 | 23-11829-050 | 1 ea |
| | STANDARD | Zip Tie | 23-09796-629 | 2 ea |
| | OTHER | Hook and Loop tape 1 in width | Other part type | 1 FT |
| SF679 A-E | STANDARD | BLANK COMPLETION STICKER | WAR261 | 1 ea |

Table 1

Removed Parts

There are no removed parts for this repair.

Labor Allowance

Table 2 - Labor Allowance

| Campaign Number | Procedure | Time Allowed (hours) | SRT Code | Corrective Action |
|-----------------|--------------------------------|----------------------|-----------|---------------------------|
| SF679 A | Install and activate VT module | 0.8 | 996-F175A | 12-Repair Recall/Campaign |
| SF679 B | Install and activate VT module | 0.8 | 996-F175B | 12-Repair Recall/Campaign |
| SF679 C | Install and activate VT module | 0.6 | 996-F175C | 12-Repair Recall/Campaign |
| SF679 D | Install and activate VT module | 0.5 | 996-F175D | 12-Repair Recall/Campaign |
| SF679 E | Install and activate VT module | 0.8 | 996-F175E | 12-Repair Recall/Campaign |

Table 2

IMPORTANT: When the campaign has been completed, locate the base completion label in the appropriate location on the vehicle, and attach the gray completion sticker (Form WAR261). If the vehicle does not have a base completion label, clean a spot on the appropriate location of the vehicle and first attach the base completion label (Form WAR259). If a field service kit is not required or there is no completion sticker in the kit, write the campaign number on a blank sticker and attach it to the base completion label.

Claims for Credit

You will be reimbursed for your parts, labor, and handling (landed cost for Export Distributors) by submitting your claim through the warranty system within 30 days of completing this campaign. Please reference the following information in OWL:

- Claim type is **Field Service Campaign**.
- In the Campaign field, enter the campaign number and appropriate condition code (**SF679-A, SF679-B, etc.**).
- In the Primary Failed Part field, enter **25-SF679-000**.
- In the Parts section, enter the kit number as shown in the Replacement Parts Table.

January 2024
SF679 A-E
(Revised October 2024)

- Select 'Other' as the part type for the Hook and Loop tape, and input the part price into the 'Part Price Claimed' field.
- In the Labor section, enter the appropriate SRT from the Labor Allowance Table. Administrative time will be included automatically as SRT 939-6010A for 0.3 hours.
- The VMRS Component Code is **F99-999-005** and the Cause Code is **A1 - Campaign**.
- This Field Service Campaign will **terminate on January 31, 2025**. Dealers will be notified of any changes to the termination date via an Important Campaign Information Letter (ICI) posted on the DTNA Portal.

IMPORTANT: OWL must be viewed prior to beginning work to ensure the vehicle is involved and the campaign has not previously been completed. Also, check for a completion sticker before beginning work.

All claims must be submitted within 30 days of the repair and within 30 days of the termination date of the campaign. U.S. and Canadian Dealers: All excess inventory to be returned to the PDC following the conclusion of the campaign must be returned in resaleable condition to the Memphis PDC within 90 days from the termination date. Please submit a PAR to request return to the Memphis PDC. (Canadian dealers should return the kits to their facing PDC.) Export Distributors: Excess inventory is not returnable.

For questions, U.S. and Canadian dealers, contact the Warranty Campaigns Department using the Warranty Support Center (WSC) app located on the DTNA Portal. Export distributors submit a WSC inquiry or contact your International Service Manager.

January 2024
SF679 A-E

Copy of Notice to Owners

Subject: Virtual Technician Module

Daimler Truck North America LLC (DTNA), on behalf of its Freightliner Trucks Division, and wholly owned subsidiary, Western Star Truck Sales, Inc., is initiating Field Service Campaign SF679 to modify specific model years 2023-2024 Freightliner 108SD, 114SD, 122SD, Business Class M2, and Coronado; Western Star 4700, 4900, and 6900, vehicles manufactured from March 9, 2022, through October 11, 2023.

Certain vehicles spec'd with a Virtual Technician module (VT), were shipped without the VT module due to a parts shortages.

The VT module will be installed.

Please contact an authorized DTNA dealer to arrange to have the campaign performed and to ensure that parts are available at the dealership. The campaign will take approximately one hour and will be performed **free of charge**. To locate an authorized dealer, search online at northamerica.daimlertruck.com/contact-us. Scroll down to "Locate a Dealer," and select the appropriate brand.

This Field Service Campaign will **terminate on January 31, 2025**. Please make sure the campaign is completed prior to this date. Work completed after this date will be done at the customer's expense.

As stated in the terms of your express limited warranty, DTNA will not pay for any damage caused by failure to properly maintain your vehicle. DTNA considers the work necessary under this campaign to be proper maintenance and will, therefore, not pay for any damage to your vehicle caused by your failure to have the repairs that are the subject of this campaign performed in a reasonable time.

Contact the Warranty Campaigns Department at (800) 547-0712, from 7 a.m. to 4 p.m. Pacific Time, Monday through Friday, e-mail address DTNA.Warranty.Campaigns@DaimlerTruck.com, or the Customer Assistance Center at (800) 385-4357, if you have any questions or need additional information.

WARRANTY CAMPAIGNS DEPARTMENT

Enclosure

January 2024
SF679 A-E
(Revised October 2024)

Work Instructions

Subject: Virtual Technician Module

Models Affected: Specific model years 2023-2024 Freightliner 108SD, 114SD, 122SD, Business Class M2, and Coronado; Western Star 4700, 4900, and 6900, vehicles manufactured from March 9, 2022, through October 11, 2023.

REVISION:The parts table has been updated. The Hook and Loop tape part numbers listed in the parts table are intended for production purposes only and are not available for ordering from DTNA Parts Distribution Centers (PDCs). The Hook and Loop tape should be sourced locally.

2nd REVISION:Certain vehicles in Group B with Cummins engines have been reassigned to the newly created Group E. The Parts table has been updated to include the mounting bracket and fasteners required for Virtual Technician installation. A new SRT has been added to Campaign Group E: 996-F175E ECU, VIRTUAL TECHNICIAN, POPULATION E, INSTALL (SF679), 0.8 hours. Additionally, the Work Instructions have been revised to provide supplementary details for installing the Virtual Technician on vehicles with Cummins engines that were missing the Common Powertrain Controller (CPC) mounting bracket.

SF679A (Business Class M2, 108SD, and 114SD | Flat Dash) – Installation of the Virtual Technician (VT) Module

1. Check the base label (Form WAR259) for a completion sticker for SF679 (Form WAR261), indicating this work has been done. The base label is usually located on the passenger-side door, about 12 inches (30 cm) below the door latch. If a completion sticker is present, no work is needed. If a completion sticker is not present, proceed to the next step.

January 2024
SF679 A-E
(Revised October 2024)

- Remove the right-hand dash panel. See **Fig. 1**. For instructions, see **Group 60** of the applicable workshop manual.

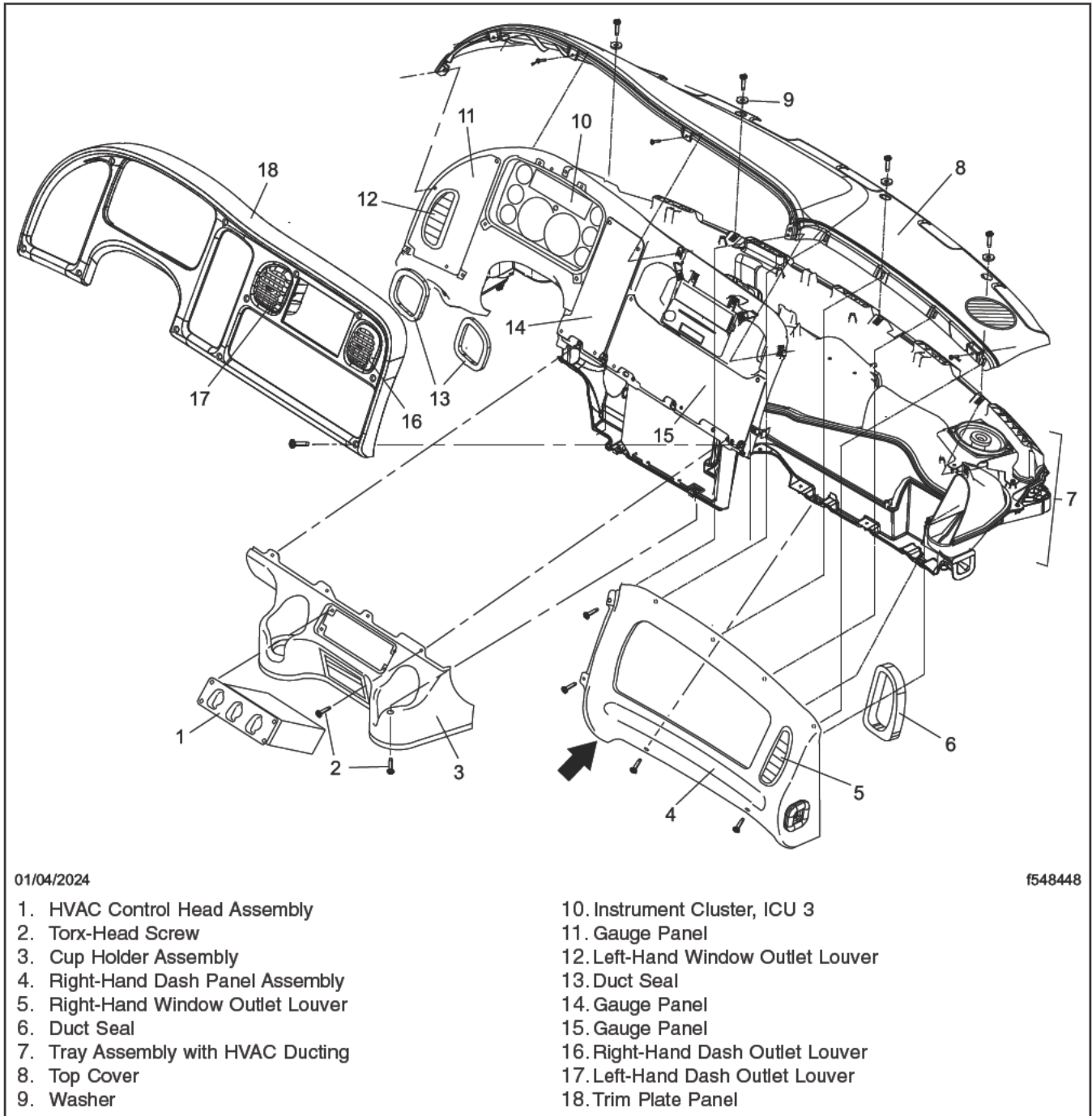

Fig. 1, Dash Components

- Write down the 'Zonar GPS ID#' on the label at the back of the VT unit. This will be needed later in the validation step.

January 2024
SF679 A-E
(Revised October 2024)

7. Go to the validation procedure (on page 22) to confirm the VT module communicates with the vehicle.

SF679B (Business Class M2, 108SD, and 114SD | Wing Dash | Non-Cummins Engines) – Installation of the Virtual Technician (VT) Module

1. Check the base label (Form WAR259) for a completion sticker for SF679 (Form WAR261), indicating this work has been done. The base label is usually located on the passenger-side door, about 12 inches (30 cm) below the door latch. If a completion sticker is present, no work is needed. If a completion sticker is not present, proceed to the next step.

January 2024
SF679 A-E
(Revised October 2024)

2. Remove the passenger-side dash panel. See **Fig. 4**. For instructions, see **Group 60** of the applicable workshop manual.

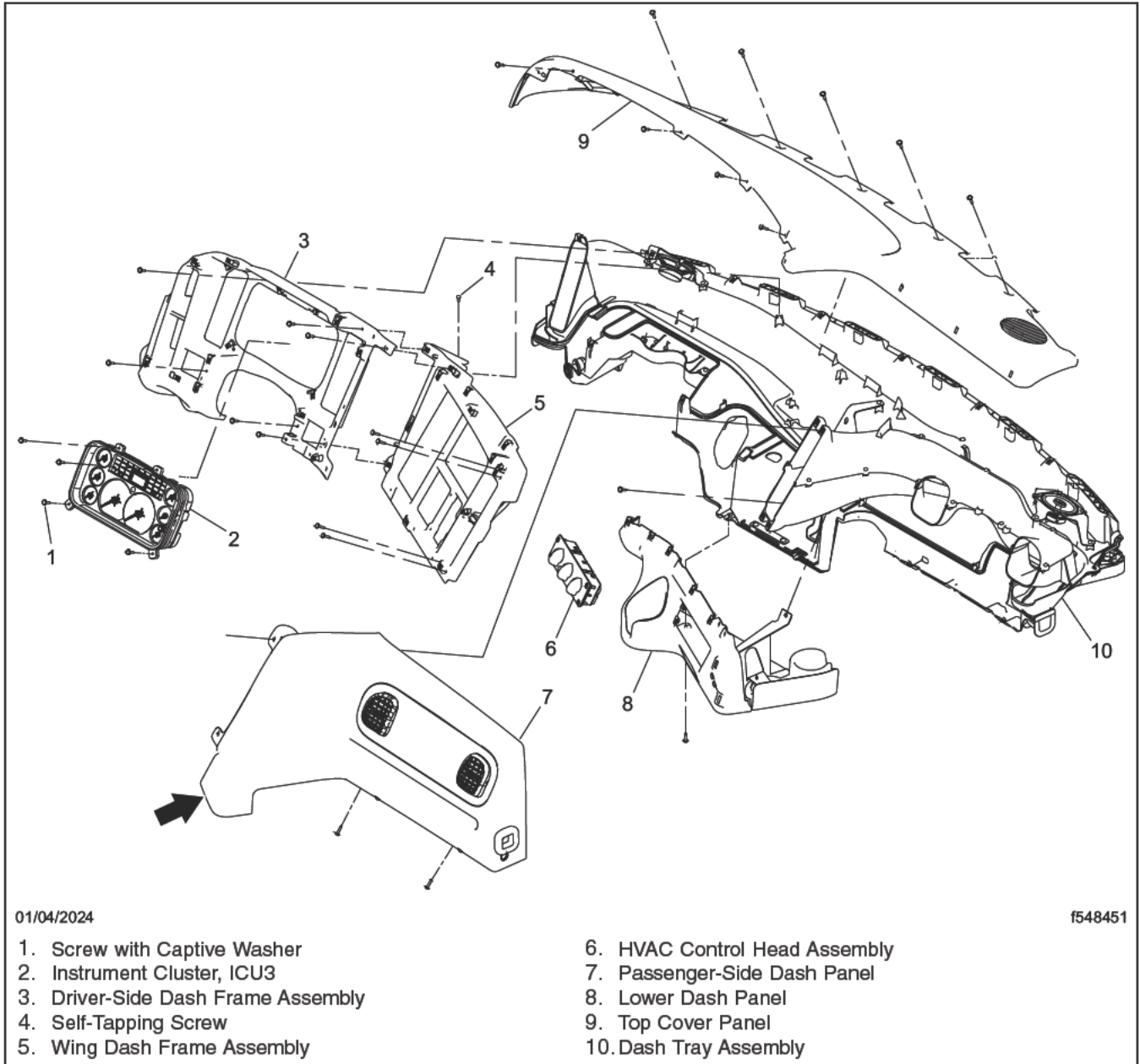

Fig. 4, Dash Components

January 2024
SF679 A-E
(Revised October 2024)

3. Remove the common powertrain controller (CPC) from the CPC bracket and put it aside. See [Fig. 5](#)

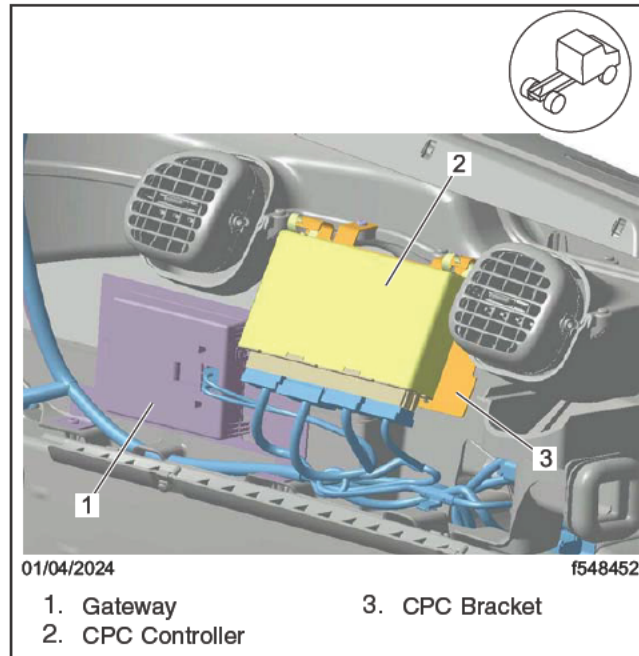

Fig. 5, CPC Module and Bracket

January 2024
SF679 A-E
(Revised October 2024)

4. Remove the CPC bracket from the dash assembly. See [Fig. 6](#).

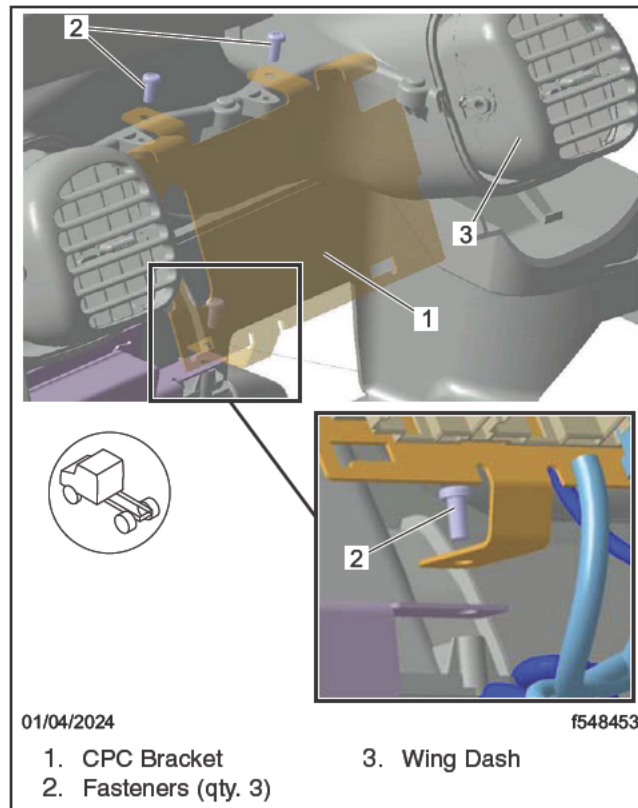

Fig. 6, CPC Bracket

5. Write down the 'Zonar GPS ID#' on the label at the back of the VT unit. This will be needed later in the validation procedure.

January 2024
SF679 A-E
(Revised October 2024)

NOTE: The VT module, shown in [Fig. 7](#), is shown on the back side of the CPC bracket.

6. Use the hook and loop tape to install the VT module on the backside of the CPC bracket. See [Fig. 7](#).

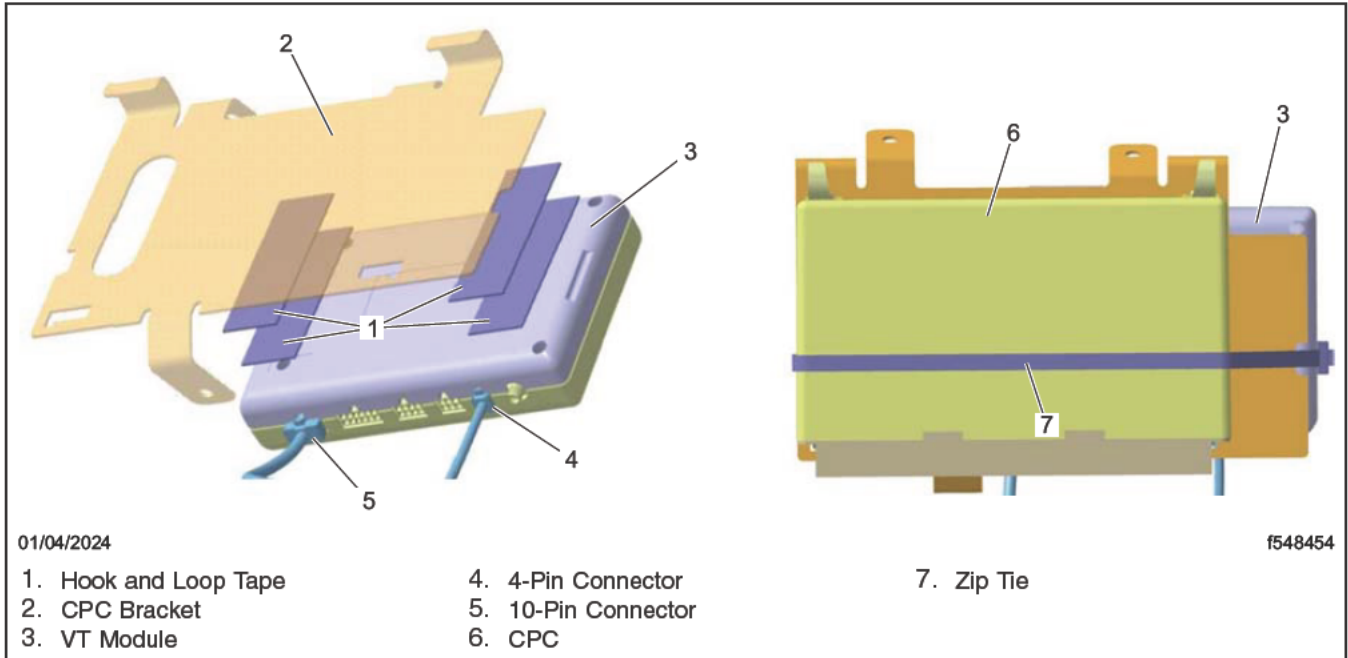

Fig. 7, VT Module Installation on the CPC Bracket

7. Locate the 10-pin and 4-pin electrical connectors, and attach them to the VT module, as shown in [Fig. 8](#).

8. Install the CPC bracket on the dash assembly.

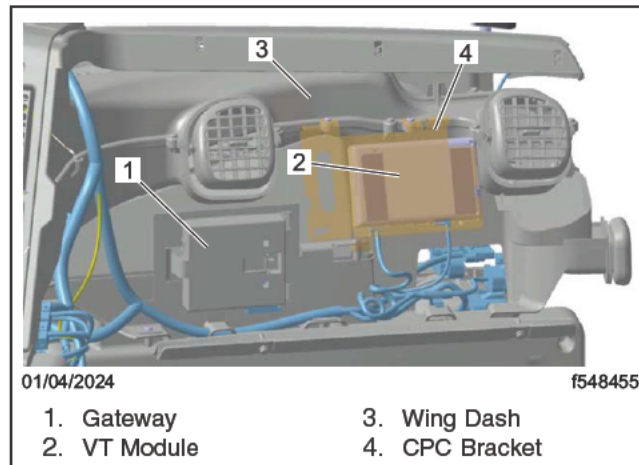

Fig. 8, VT Module Installation on the Back Side of the CPC Bracket

9. Install the CPC on the CPC bracket.

10. Use zip ties to secure both the VT module and the CPC to the CPC bracket, as shown in [Fig. 8](#).

11. Install the dash panels. For instructions, see **Group 60** of the applicable workshop manual.

January 2024
SF679 A-E
(Revised October 2024)

12. Go to the validation procedure (on page 22) to confirm the VT module communicates with the vehicle.

SF679C (Western Star 4700/4900/6900) – Installation of the Virtual Technician (VT) Module

1. Check the base label (Form WAR259) for a completion sticker for SF679 (Form WAR261), indicating this work has been done. The base label is usually located on the passenger-side door, about 12 inches (30 cm) below the door latch. If a completion sticker is present, no work is needed. If a completion sticker is not present, proceed to the next step.
2. Remove the right-hand side glove box/PDM3 cover panel, shown as item #4 in **Fig. 9**. For instructions, see **Section 60.06** of the *4700/5700/4900/6900 Workshop Manual*.

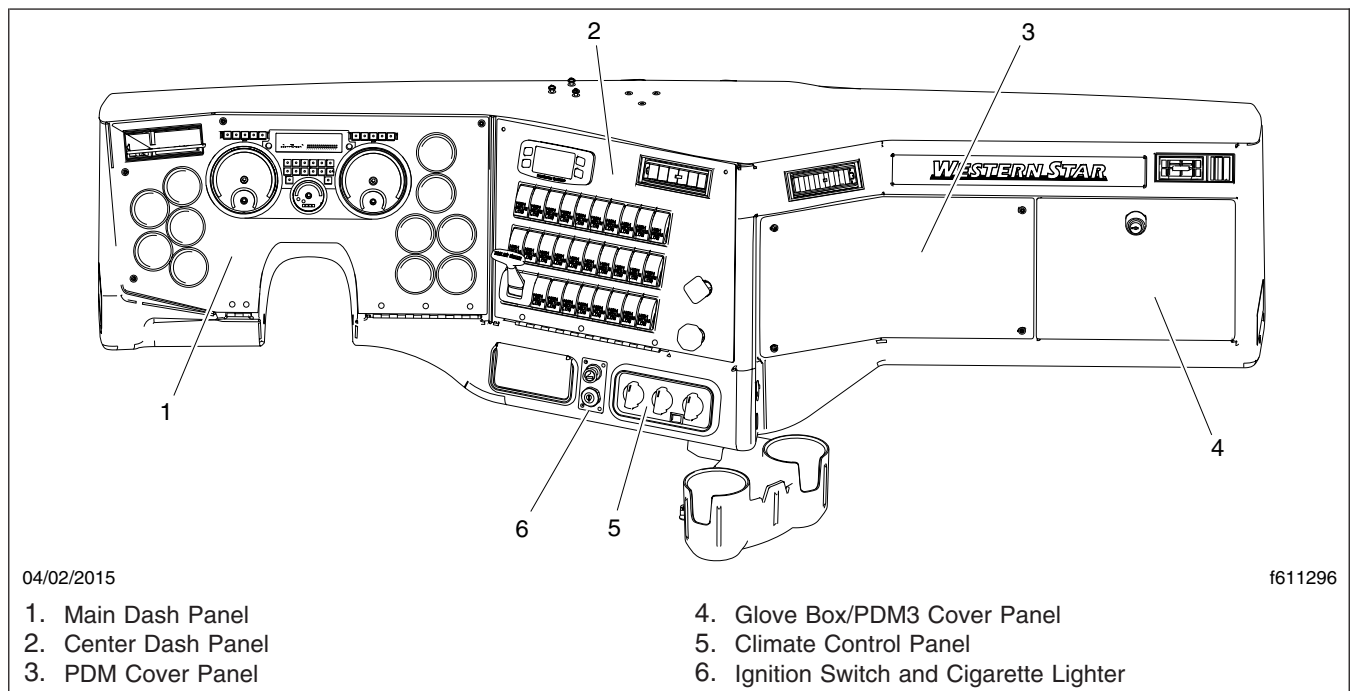

Fig. 9, Dash Panel Layout

January 2024
SF679 A-E
(Revised October 2024)

3. Release the tangs and remove the PDM3, as shown in [Fig. 10](#). Leave the PDM3 suspended by the harness.



Fig. 10, PDM Locations

NOTE: For clarity in power distribution module (PDM) identification, [Fig. 10](#) shows the cover removed from PDM1 and PDM2. It is only necessary to remove the panel covering the PDM3.

4. Write down the 'Zonar GPS ID#' on the label at the back of the VT unit. This will be needed later in the validation procedure.

January 2024
SF679 A-E
(Revised October 2024)

5. Install the VT module on the bracket accessed through the opening created by removing the PDM3. See [Fig. 11](#) and [Fig. 12](#).

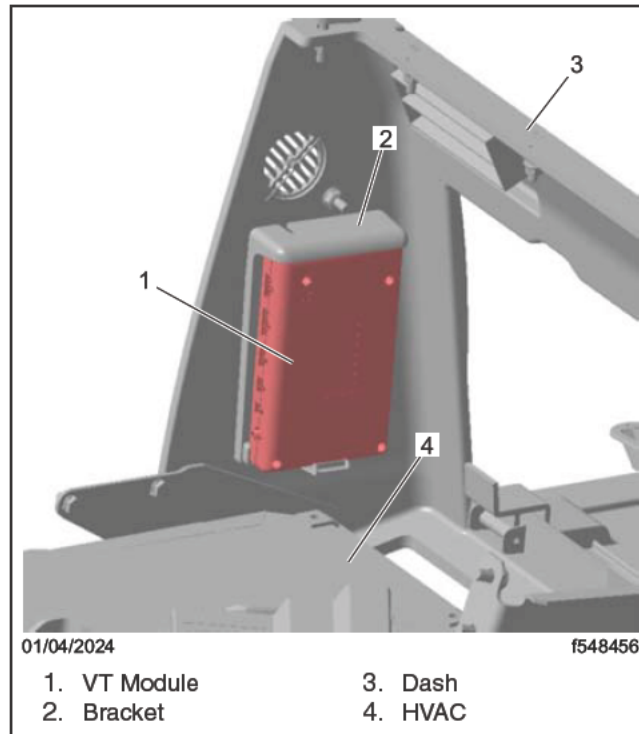

Fig. 11, VT Module Installation

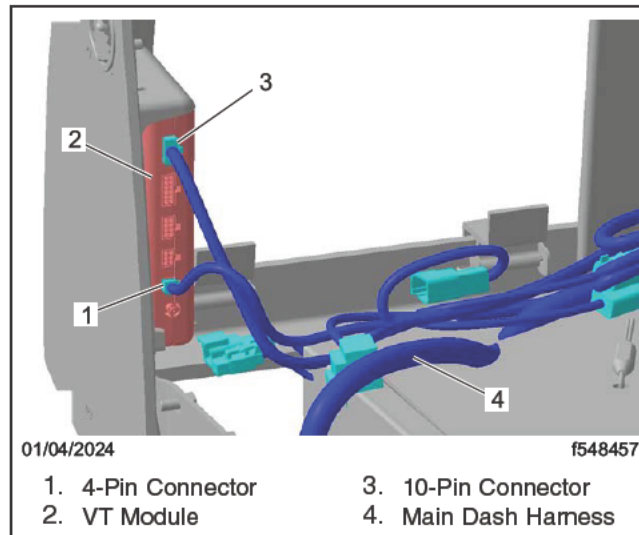

Fig. 12, Connecting the Harness Connectors to the VT Module

6. Locate the 10-pin and 4-pin electrical connectors, and attach them to the VT module, as shown in [Fig. 12](#).
7. Install the PDM3.
8. Install the right-hand side glove box/PDM3 cover panel.

January 2024
SF679 A-E
(Revised October 2024)

9. Go to the validation procedure (on page 22) to confirm the VT module communicates with the vehicle.

SF679D (122SD) – Installation of the Virtual Technician (VT) Module

1. Check the base label (Form WAR259) for a completion sticker for SF679 (Form WAR261), indicating this work has been done. The base label is usually located on the passenger-side door, about 12 inches (30 cm) below the door latch. If a completion sticker is present, no work is needed. If a completion sticker is not present, proceed to the next step.

NOTE: The sunglasses pocket is located on the passenger side, near the center of the overhead console.

2. Remove the two screws that attach the sunglasses pocket to the overhead console. Remove the sunglasses pocket. See [Fig. 13](#).



Fig. 13, Sunglasses Pocket Removal from the Overhead Console

3. Write down the 'Zonar GPS ID#' on the label at the back of the VT unit. This will be needed later in the validation procedure.

January 2024
SF679 A-E
(Revised October 2024)

4. Use hook and loop tape to install the VT Module on the overhead console in the location shown in [Fig. 14](#) and [Fig. 15](#).

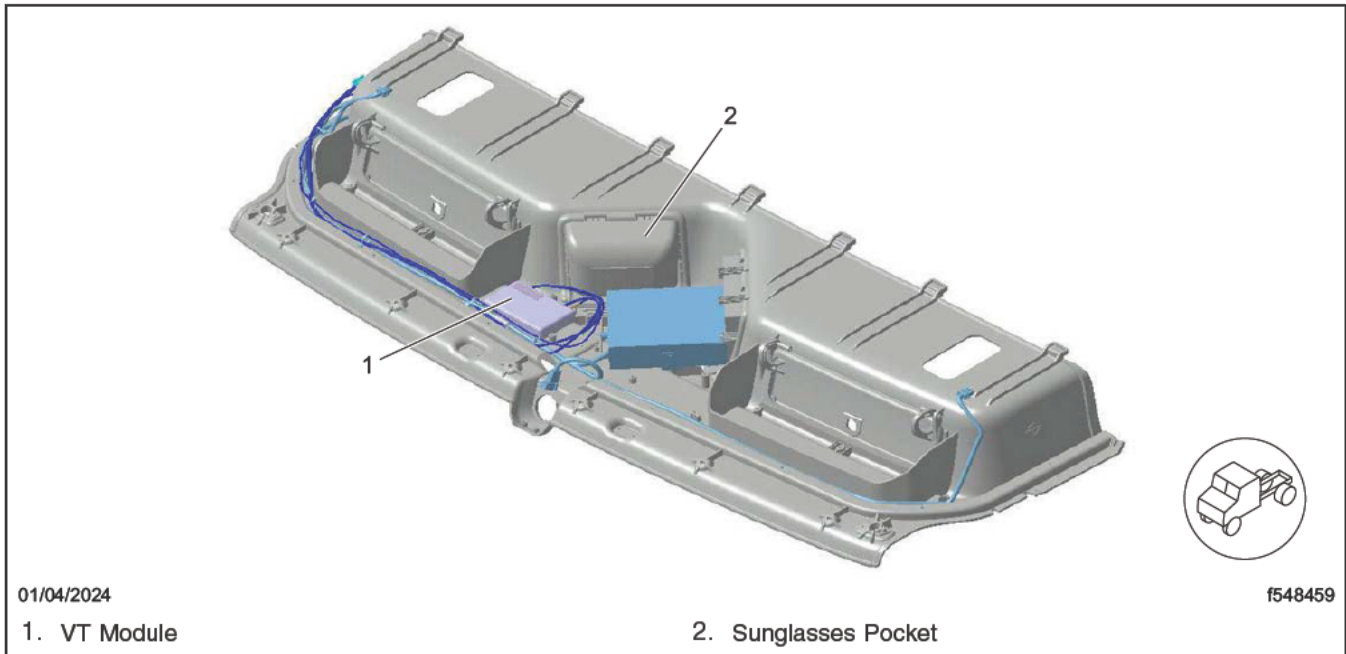

Fig. 14, VT Module Installation in the Overhead Console

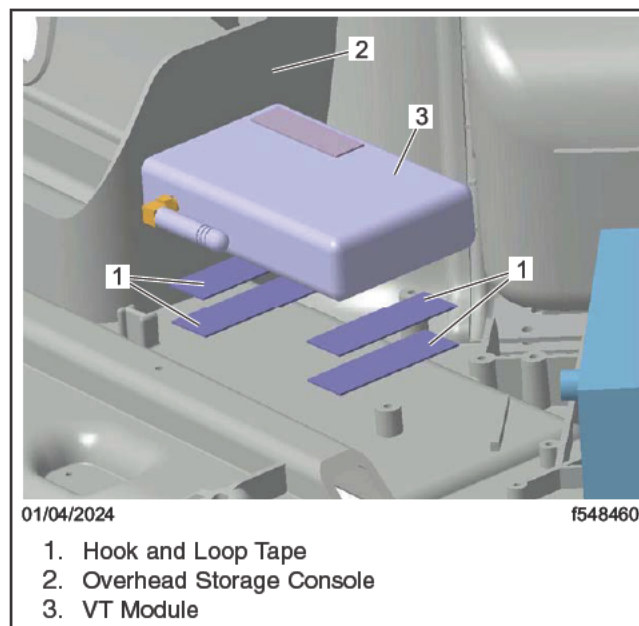

Fig. 15, VT Module Installation

January 2024
SF679 A-E
(Revised October 2024)

5. Locate the 10-pin, 4-pin, and antenna connectors, and attach them to the VT module, as shown in **Fig. 16**.

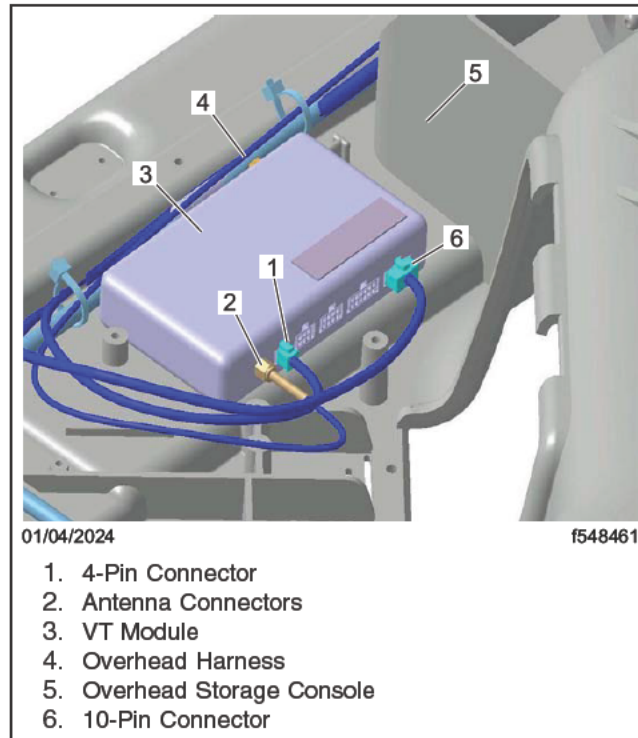

Fig. 16, VT Module Wiring Installation

6. Install the sunglasses pocket on the passenger side of the overhead console.
7. Go to the validation procedure (on page 22) to confirm the VT module communicates with the vehicle.

SF679E (Business Class M2, 108SD, and 114SD I Wing Dash I Cummins Engines) – Installation of the Virtual Technician (VT) Module

1. Check the base label (Form WAR259) for a completion sticker for SF679 (Form WAR261), indicating this work has been done. The base label is usually located on the passenger-side door, about 12 inches (30 cm) below the door latch. If a completion sticker is present, no work is needed. If a completion sticker is not present, proceed to the next step.

January 2024
SF679 A-E
(Revised October 2024)

2. Remove the passenger-side dash panel. See [Fig. 17](#). For instructions, see **Group 60** of the applicable workshop manual.

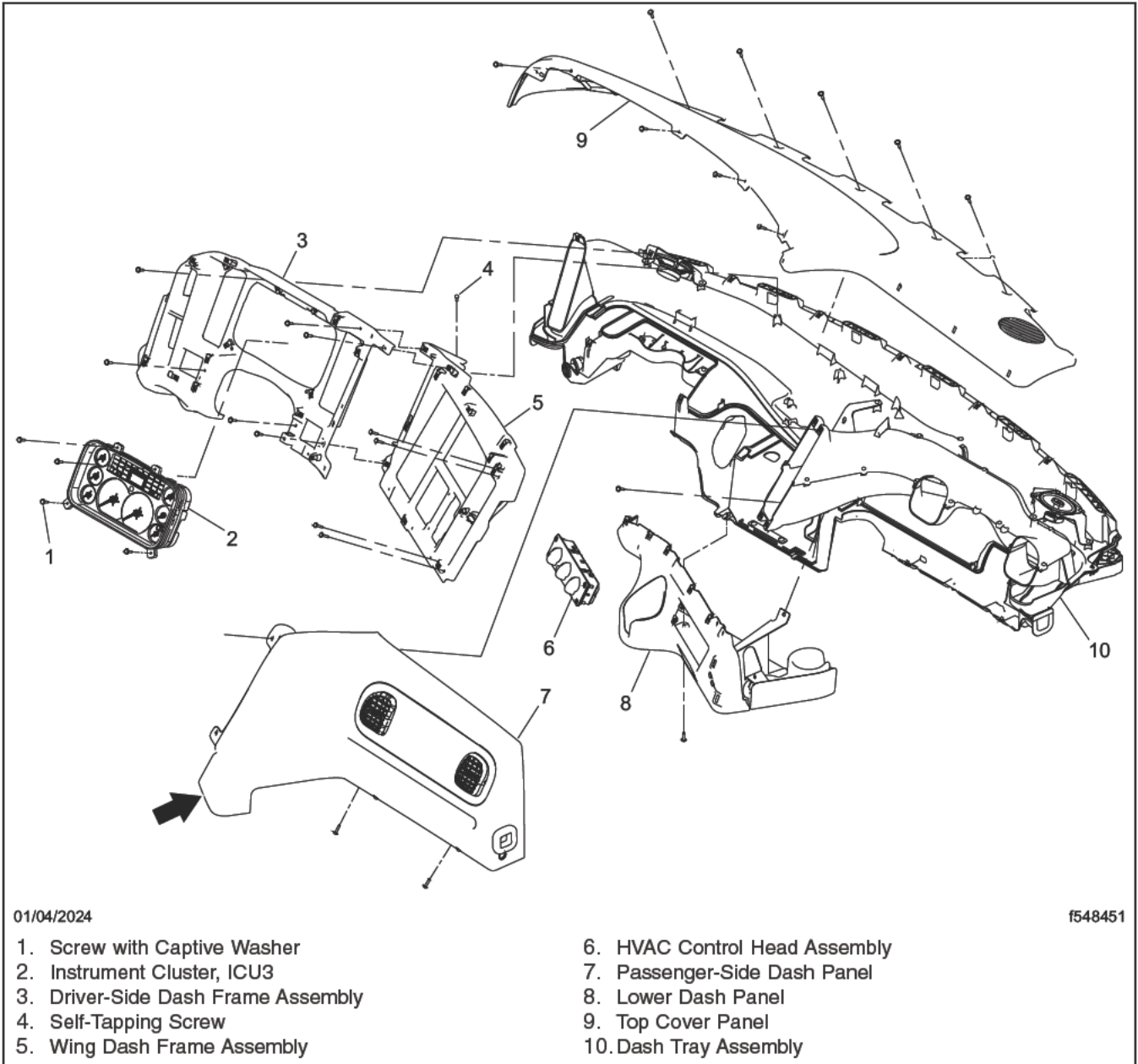

Fig. 17, Dash Components

January 2024
SF679 A-E
(Revised October 2024)

3. Make a note of how the new bracket is installed in the dash prior to attaching the VT module. See **Fig. 18**. The VT module will be fastened to the back side of the new bracket (between the bracket and the dash assembly), prior to attaching the bracket to the dash.

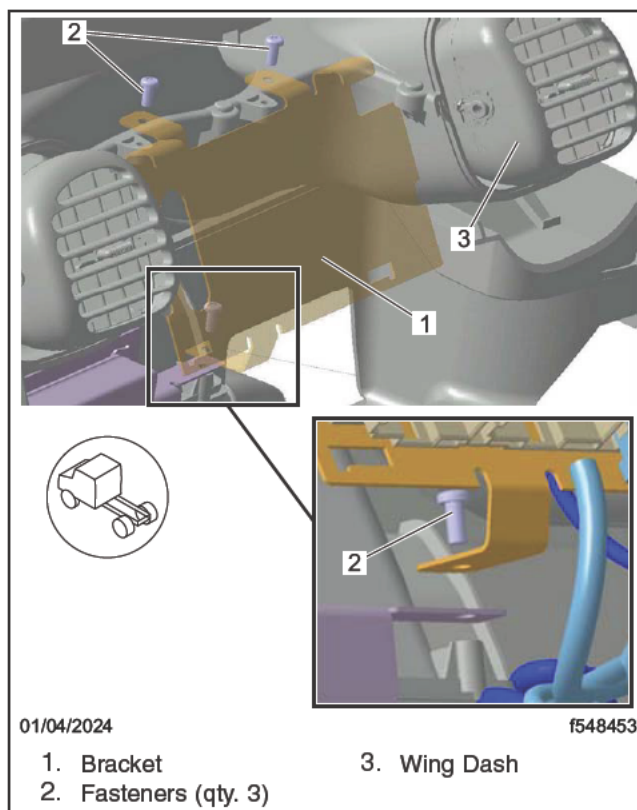

Fig. 18, Bracket

4. Write down the 'Zonar GPS ID#' on the label at the back of the VT unit. This will be needed later in the validation procedure.

January 2024
SF679 A-E
(Revised October 2024)

NOTE: The VT module, shown in [Fig. 19](#), is shown on the back side of the new bracket.

5. Use the hook and loop tape to install the VT module on the back side of the new bracket. Secure the VT module to the bracket with zip ties as shown in [Fig. 19](#).

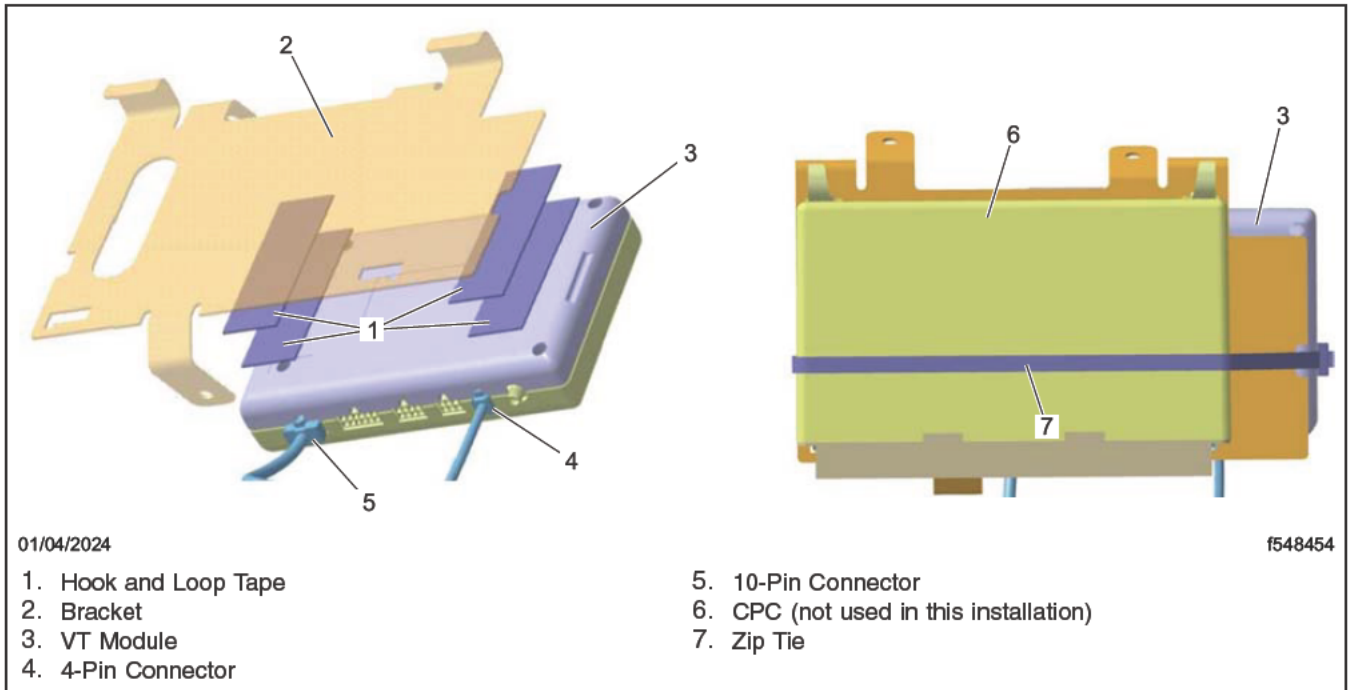

Fig. 19, VT Module Installation on the Bracket

6. Locate the 10-pin and 4-pin electrical connectors, and attach them to the VT module, as shown in [Fig. 20](#).
7. Use three screws to install the bracket (with the VT module already attached) on the dash assembly.

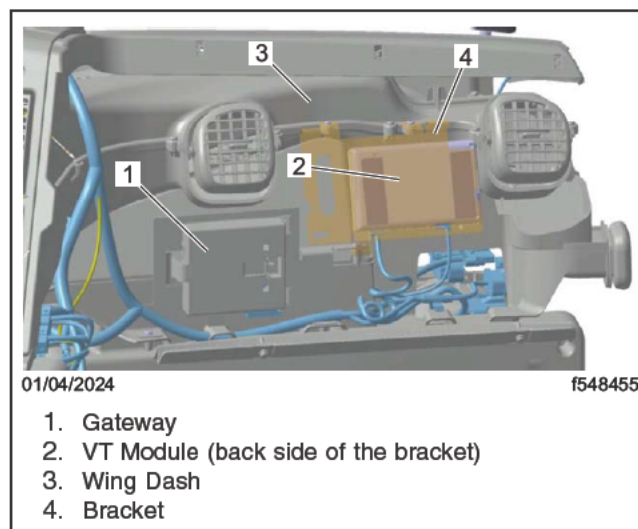

Fig. 20, VT Module Installation on the Back Side of the Bracket

8. Install the dash panels. For instructions, see **Group 60** of the applicable workshop manual.

January 2024
SF679 A-E
(Revised October 2024)

9. Continue with the validation procedure below to confirm the VT module communicates with the vehicle.

SF679A-E – Validating the Virtual Technician (VT) Module Communicates with the Vehicle

1. Connect the vehicle to DiagnosticLink®.
2. Turn the ignition key to the ON position.
3. Wait for all the modules to get connected, and make sure 'J1939-74' is visible and rollcalls in the 'Connections' window.
4. Go to the 'Identification' tab, then select the 'Standard' tab.
5. Scroll down to 'J1939-74 – Communications Unit, Cellular,' and check the 'ECU Serial Number.' See Fig. 21.

01/04/2024 f121490

A. Go to the 'Identification' tab.
B. Select the 'Standard' tab.
C. Scroll down to 'J1939-74 – Communications Unit, Cellular.'
D. Check the 'ECU Serial Number.'

Fig. 21, Verifying VT Communication on J1939 Using DiagnosticLink

January 2024
SF679 A-E
(Revised October 2024)

6. The electronic control unit (ECU) serial number should match the Zonar GPS ID# on the label at the back of the VT unit.
 - If the ECU serial number matches the Zonar GPS ID# → Go to step 7.
 - If the ECU serial number does not show a value, or if the VT module does not communicate → Check the wiring connection at the VT module. If the problem persists, troubleshoot and repair as needed.
7. Disconnect the vehicle from DiagnosticLink.

NOTE: The customer must be reminded to operate the vehicle continuously for 20 minutes (key on, engine running) for the Virtual Technician module to fully activate with Zonar's servers.

8. Clean a spot on the base label (Form WAR259), and attach a campaign completion sticker for SF679 (Form WAR261), indicating this work has been completed.