



Service Action Code: 90X1

Subject Instrument Cluster

Document History

| Date | Summary |
|------------|-------------------------------|
| 10/30/2024 | Updated claiming instructions |
| 01/25/2024 | Original publication |

Affected Vehicles

| Country | Beginning Model Year | Ending Model Year | Vehicle | Vehicle Count |
|---------|----------------------|-------------------|---------|---------------|
| USA | 2020 | 2020 | JETTA | 6 |

Check Campaigns/Actions screen in ELSA on the day of repair to verify that a VIN qualifies for repair under this action. ELSA is the only valid campaign inquiry & verification source.

- ✓ Campaign status must show "open."
- ✓ If ELSA shows other open action(s), inform your customer so that the work can also be completed at the same time the vehicle is in the workshop for this campaign.

About this Service Action

Volkswagen is providing a hardware and/or a software update to address an issue in selected vehicles where the fuel gage may show a lower fuel level than what is actually remaining in the vehicle.

Code Visibility

On or about January 25, 2024, the campaign code will be applied to affected vehicles.

Owner Notification

Owner notification will take place in January 2024. Owner letter examples are included in this bulletin for your reference.

Campaign Expiration Date

This campaign expires on **January 25, 2029**. Work must be performed on or before this date to be eligible for payment. Keep this expiration date in mind when scheduling customers for this action. If a customer wishes to have this work performed after the expiration date, your normal parts and labor cost associated with this work will apply.

Additional Information

Please alert everyone in your dealership about this action, including Sales, Service, Parts and Accounting personnel. Contact Warranty if you have any questions.

Dealers must ensure that every affected inventory vehicle has this campaign completed before delivery to consumers.

Fill out and affix Campaign Completion Label (CAMP 010 000) after work is complete. Labels can be ordered at no cost via the Compliance Label Ordering portal at www.vwclub.com.

Parts Information (Only if replacement is required)

| Criteria | Quantity | Part Number | P.O.C. Part Description | Ordering Method (see description below) |
|----------|----------|---------------|-------------------------|--|
| 01 | 1 | 17A-920-890-B | COMB.INST. | Free Order |

| | |
|---|-------------------------------------|
| Parts Control Type: Free Order | Parts will be managed by Free Order |
|---|-------------------------------------|

| | |
|---|--|
| Initial Allocation: NO | Please reference the Repair Projection Tool (below) to view your potential VIN population. |
|---|--|

NOTE

Your dealer's Estimated Remaining Repairs by campaign can be found in Parts on Command. Click on "View Campaign List" and review the Estimated Remaining Repairs column.

NOTE

Campaign parts should always be ordered as per the parts information in this circular. The ordering system will supersede the part, if applicable.

Claim Entry Instructions

The labor times listed here may differ from the labor operations and labor times listed in ELSA.

After campaign has been completed, enter claim as soon as possible to help prevent work from being duplicated elsewhere. Attach the ELSA screen print showing action open on the day of repair to the repair order.

If customer refused campaign work:

- ✓ U.S. dealers: Submit request via WISE under the *Campaigns/Update/Recall Closure* option.

| | | | |
|----------------------------|--|------------------------------------|------------------------------------|
| Service Number | 90X1 | | |
| Damage Code | 0099 | | |
| Parts Vendor Code | WWO | | |
| Claim Type | Sold vehicle: 7 10 Unsold vehicle: 7 90 | | |
| Causal Indicator | Mark labor as causal if instrument cluster does not require replacement. Mark COMB.INST.* as causal if instrument cluster is replaced. | | |
| Vehicle Wash/Loaner | Do not claim wash/loaner under this action U.S.A.: Loaner/rental coverage cannot be claimed under this action. However, loaner/rental may be covered under the Alternate Transportation Program. Please refer to the Volkswagen Warranty Policy and Procedures Manual for loaner claims information and reimbursement details. | | |
| Criteria I.D. | 01 | | |
| | Check instrument cluster software and hardware levels with ODIS. Instrument cluster software update is required: update software via SD card and document software version via SVM. | | |
| | LABOR | | |
| | Labor Op | Time Units | Description |
| | 0150 00 10 | SEE ELSA | GFF/Guided functions |
| | 0150 00 60 | Time stated on diagnostic protocol | GFF/Guided functions |
| | 9025 25 99 | 60 TU | Update instrument cluster software |

Continued on next page

| | | | |
|-----------|--|------------------------------------|-------------------------------------|
| OR | Check instrument cluster software and hardware levels with ODIS. Instrument cluster replacement is required. | | |
| | LABOR | | |
| | Labor Op | Time Units | Description |
| | 0150 00 10 | SEE ELSA | GFF/Guided functions |
| | 0150 00 60 | Time stated on diagnostic protocol | GFF/Guided functions |
| | 9025 19 02 | SEE ELSA | Instrument cluster remove+reinstall |
| | 9025 55 50 | SEE ELSA | Instrument cluster replace |
| | PARTS | | |
| | Quantity | Part Number | Description |
| | 1.00 | 17A920890B | COMB.INST* |

Customer Letter Example (USA)

<MONTH YEAR>

<CUSTOMER NAME>

<CUSTOMER ADDRESS>

<CUSTOMER CITY STATE ZIPCODE>

This notice applies to your vehicle: <MODEL YEAR> <BRAND> <CARLINE>, <VIN>

Subject: Service Action 90X1 – Instrument Cluster

Dear Volkswagen Owner,

As part of Volkswagen's ongoing commitment to customer satisfaction, we are informing you of our decision to conduct a service action on certain 2020 model year Volkswagen vehicles. Our records show that you are the owner of a vehicle affected by this action.

About this Service Action: Volkswagen is providing a hardware and/or a software update to address an issue in selected vehicles where the fuel gage may show a lower fuel level than what is actually remaining in the vehicle.

This work will take up to two hours to complete and will be performed for you free of charge. Please keep in mind that your dealer may need additional time for the preparation of the work, as well as to accommodate their daily workshop schedule.

What should you do? Please contact your authorized Volkswagen dealer as soon as possible to schedule this work. To set up an appointment online, please visit www.vw.com/find-a-dealer.

This service action will be available for you **free of charge only until January 25, 2029**. If you wish to have this work performed after that date, your dealer's normal costs associated with this repair will apply.

Lease vehicles and address changes If you are the lessor and registered owner of the vehicle identified in this action, please forward this letter immediately via first-class mail to the lessee within ten (10) days of receipt. If you have changed your address or sold the vehicle, please fill out the enclosed prepaid Owner Reply card and mail it to us so we can update our records.

Can we assist you further? If your authorized Volkswagen dealer fails or is unable to complete this work free of charge within a reasonable time, or if you should have any questions about this communication, please reach out to us using your preferred method of communication at www.vw.com/contact or by calling us at 800-893-5298.

Checking your vehicle for open Recalls and Service Campaigns To check your vehicle's eligibility for repair under this or any other recall/service campaign, please visit www.vw.com/owners/recalls and enter your Vehicle Identification Number (VIN) into the Recall/Service Campaign Lookup tool.

We apologize for any inconvenience this matter may cause; however we are taking this action to help ensure your vehicle continues to meet and exceed your expectations.

Sincerely,

Volkswagen Customer Protection

Repair Overview

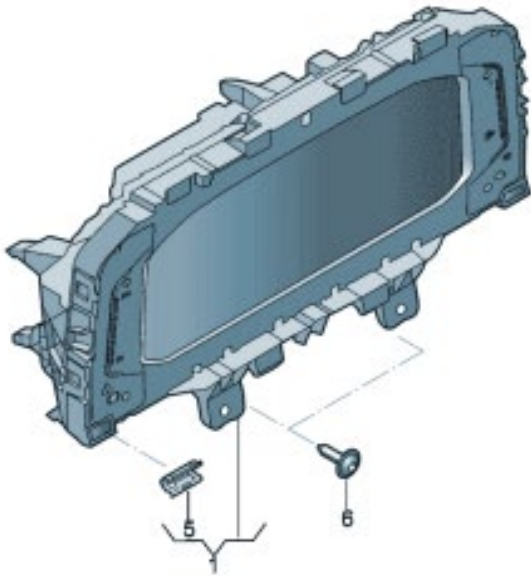

- Check instrument cluster software and hardware levels.
- Update instrument cluster software if necessary -OR- replace instrument cluster if necessary.

NOTE

- These repair instructions may differ from the labor operations and labor times listed in ELSA.
- Damages resulting from improper repair or failure to follow these work instructions are the dealer's responsibility and are not eligible for reimbursement under this action.
- This procedure must be read in its entirety prior to performing the repair.
- Due to variations in vehicle equipment and options, the steps/illustrations in this work procedure may not identically match all affected vehicles.
- Diagnosis and repair of pre-existing conditions in the vehicle are not covered under this action.
- When working during extreme temperatures, it is recommended that the vehicle be allowed to acclimate inside the shop to avoid temperature-related component damage/breakage.

Required Tools

| | |
|--|--|
|  <p>Battery Tester/Charger capable of minimum 70 Amp continuous supply</p> |  <p>Diagnostic Tester -VAS6150X/VAS6160X- (or equivalent)</p> |
|  <p>Hook -T10538- (qty. 2)</p> |  <p>Fiber-Optic Repair Set - Connector Protective Caps -VAS6223/9-</p> |

Required SD Card (Software update only)

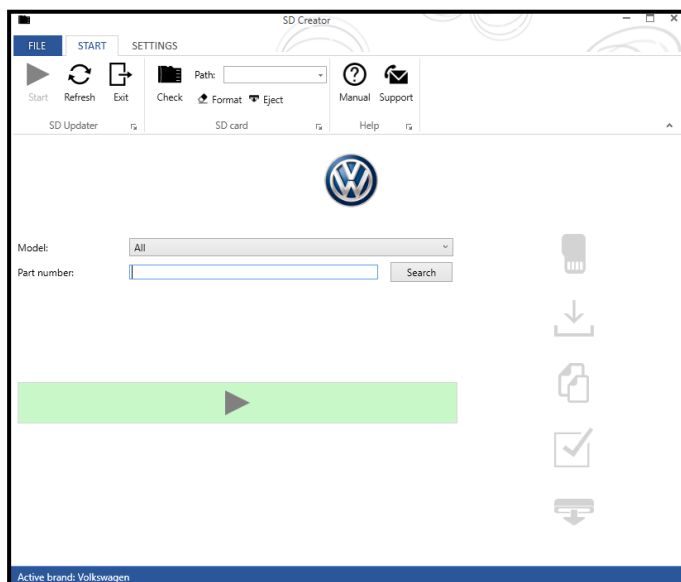

- The required software will have to be downloaded onto a SD card using the SD Creator program.
- **Reference the latest version of TSB 2054866 for additional information on the use of the SD Creator program.**

NOTE

- The required SD cards cannot be ordered via the parts ordering system; they must be created using the SD Creator program.
- The required SD cards are a servicing material. Therefore, the cost of the SD card will not be reimbursed.
- The SD card can be used for future software updates.

Software Part Number

3G0.919.360.PH

Repair Instruction

Section A - Check for Previous Repair

TIP

If Campaign Completion label is present, no further work is required.

| Applicable criteria ID(s) | Campaign/Action Status |
|--|--|
| 01  | Open  |

EXAMPLE

| Campaign/Action | Start | Designation |
|--|------------|--------------|
|  | 2015-11-10 | W-SERV_ACT - |
| | 2018-12-13 | RECALL - |
| | 2017-05-16 | A-RECALL - |

EXAMPLE

- Enter the VIN in Elsa and proceed to the “Campaign/Action” screen.

TIP

On the date of repair, print this screen and keep a copy with the repair order.

- Confirm the Campaign/Action is open <arrow 1>. If the status is closed, no further work is required.
- Note the Applicable Criteria ID <arrow 2> for use in determining the correct work to be done and corresponding parts associated.

CRITICAL REPAIR STEP



If multiple software update Campaign/Actions are open, they must be performed in order of the Start date <arrow 3>. The oldest should be performed first.

- **All Safety Recalls must be completed prior to completing this campaign.**
- **Proceed to Section B**

Section B – Check Instrument Cluster Software and Hardware Levels

Check instrument cluster software:

- Open the hood.
- Open the battery cover.
- Switch the ignition on.
- Apply the parking brake.
- Switch off all consumers (headlights, heated seats, climate control, etc.).
- Connect the VAS6150X/VAS6160X Diagnostic Tester to the vehicle.
- Start the ODIS program.
- Attach the battery charger to the vehicle battery.

! NOTE

Vehicles with Battery Monitoring Control Module -J367- and/or an EFB Battery:

When connecting the charger to the battery, connect the positive cable to the positive terminal of the battery and connect the negative cable to the grounding lug on the chassis. DO NOT connect the ground cable directly to negative terminal of the battery.

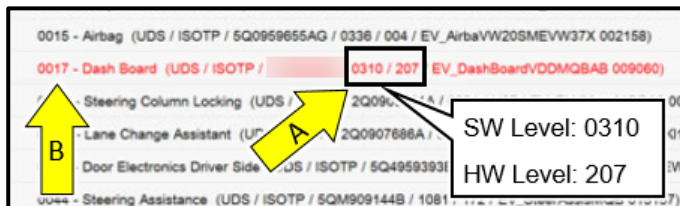

- Using ODIS, check the software and hardware levels <arrow A> of the Instrument cluster, DA 0017 <arrow B>.

! NOTE

The instrument cluster pictured would require replacement as the hardware level is below 503.

- If the software level is equal to or higher than 4194 with a hardware level of 503:
 - No further work is necessary.
 - Proceed to section E.
- If the software level is below 4194 with a hardware level of 503:
 - The instrument cluster software must be updated.
 - Proceed to section C.
- If the hardware level is below 503:
 - The instrument cluster must be replaced.
 - Proceed to section D.

Section C – Update Instrument Cluster Software

NOTE

Prior to launching the VAS Diagnostic Tester and starting an update, ensure the following conditions are met;

- ✓ **The ODIS software is completely up to date.**
 - Refer to the “Current ODIS Service Version” document in the Service References section of ELSA 2 Go.
- ✓ **The battery charger is connected to the vehicle battery and remains connected for the duration of the software update.**
 - Battery voltage must remain above 12.5 volts for the duration of the software update. Failure to do so may cause the update to fail, which could result in damage to the control module. Control modules damaged by insufficient voltage will not be covered.
- ✓ **The screen saver and power saving settings are off.**
 - Failure to do so may result in the tester entering power save mode during the software update, which could result in damage to the control module.
- ✓ **The VAS Diagnostic Tester is plugged in using the supplied power adapters.**
 - Under no circumstances should the tester be used on battery power alone during the software update. Failure to do so may result in the tester powering off during the update, which could result in damage to the control module.
- ✓ **The VAS Diagnostics Interface MUST ONLY be connected to the tester with a USB cable.**
 - Performing a software update using a Bluetooth or WiFi connection increases the risk of losing connection during the update, which could result in damage to the control module. It also greatly increases the time required to perform the update. Requests for additional time or parts will be denied if the GFF log shows the update was performed using Bluetooth or WiFi.

WARNING

Radiator Fan(s) may cycle ON high speed during the Update Process! There is a serious risk that personal injury may result if contact is made with spinning fan blades. Keep hands and all objects away from Radiator Fan(s) during Update Process!

TIP

To Update-Programming using SVM, review and follow instructions in Technical Bulletin 2014603: *Software Version Management (SVM) Operating Instructions*.

The SVM Process must be completed in its entirety so the database receives the update confirmation response. A warranty claim may not be reimbursed if there is no confirmation response to support the claim.

NOTE

- Damages resulting from improper repair or failure to follow these work instructions are the dealer's responsibility and are not eligible for reimbursement under this action.
- Diagnosis and repair of pre-existing conditions in the vehicle are not covered under this action.

NOTE

- All campaign software updates must be completed during a single, standalone ODIS Diagnostic Session. You must fully complete this campaign and send all logs before beginning any other campaigns or operations.
- If there are any ODIS "Hot-Fix" patches installed, they must be removed from the scan tool before beginning this operation. ODIS "Hot-Fix" patches may affect the update process.



Update instrument cluster software:

- Turn the hazards on.

CAUTION

The procedure may cancel itself if the hazard warning lights are not switched on. The hazard warning lights prevent the system from switching to bus sleep mode during the update.

- Insert the SD card **3G0.919.360.PH** into the SD card slot <1> of the 5F control unit in the glove box.
- Press and hold the "Menu" button on the infotainment display for 10 seconds to enter service mode.



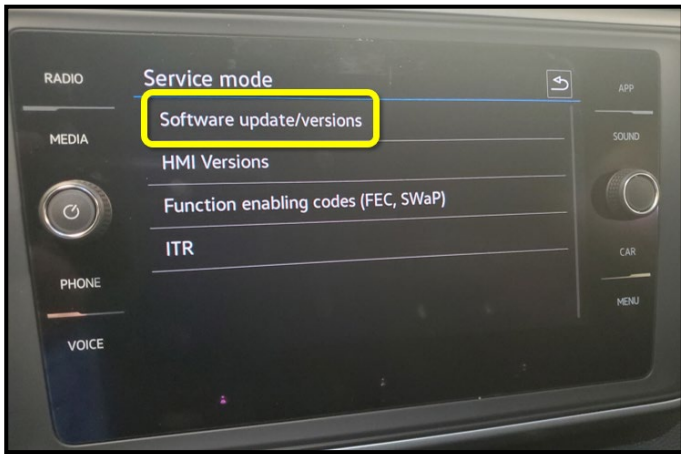

- Select the option "Software Update/Versions".
- Follow all on-screen prompts through completion of the SD card update.

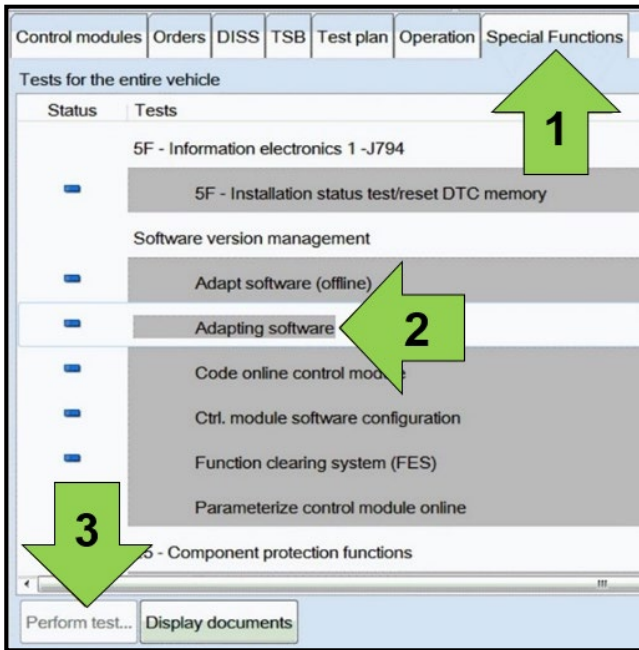

- Once the SD card update is complete, using ODIS, select "Special functions" <arrow 1>, then "Adapting software" <arrow 2>, then select "Perform test" <arrow 3>.

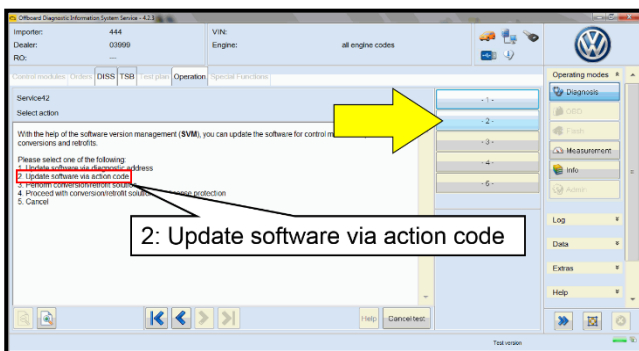

- Select the correct option to "Update software via action code" OR "Software update via measured code".

NOTE
The different options to perform the SVM operation may vary based on model.

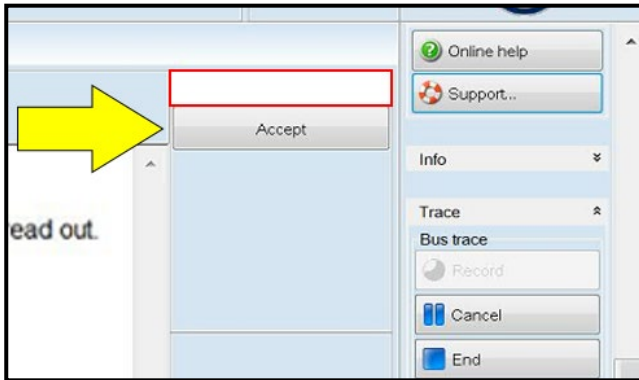
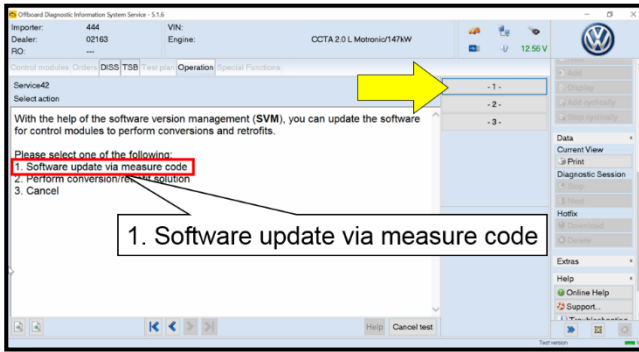

NOTE

Using Bluetooth or WiFi for this action is PROHIBITED!

Damage caused to electronic components (e.g. ECM, TCM, etc.) during the SVM flash process is not covered.

- Enter the corrective action code (SVM code) as listed below.

| |
|-----------------|
| SVM code |
| 488B |

- Select “Accept” <arrow> and follow the on screen prompts.
- During the flash, this screen appears when each operation is performed:

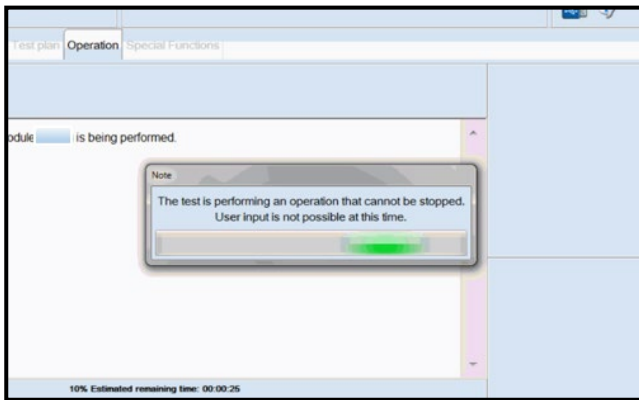

- Select Complete/Continue <arrow> after each operation is completed.

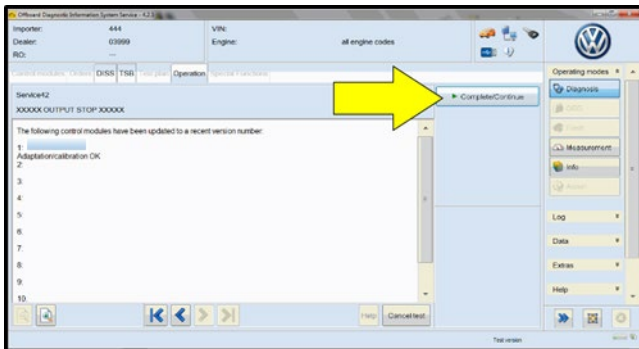

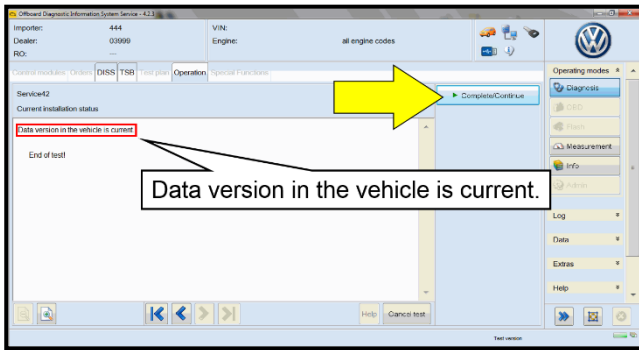

- When the SVM update is complete, a confirmation message is displayed <as shown>.
- Select “Complete/Continue” <arrow>.

TIP

If the software in the vehicle is already current, a message may appear indicating this. If this occurs, complete the ODIS test plan and send the diagnostic protocol online.

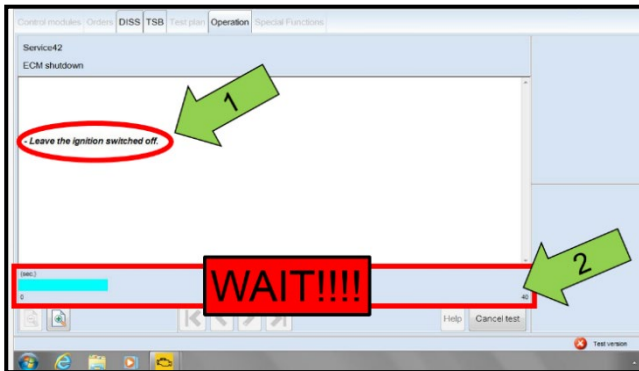

NOTE

- It is **IMPERATIVE** that **ALL** of the ignition cycle on/off delay requests are fulfilled in their entirety during this flash process <arrow 1>.
- Failing to wait for the ignition on/off timing cycle to complete (progress bar and countdown timer <arrow 2>) before cycling the ignition on/off MAY damage a control module.
- Damage to control modules as a result of failing to wait the specified time displayed by the progress bar and countdown timer <arrow 2> are **NOT** covered under this action.

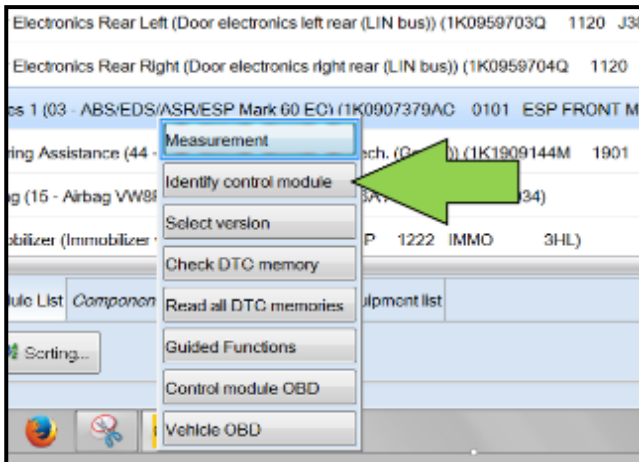

- After the software update is completed and before sending the GFF Log Online:
 - Select the “Control Module” tab.
 - Scroll down and right click on the module that was updated (DA 0017).
 - Select “Identify Control Module” <arrow>.

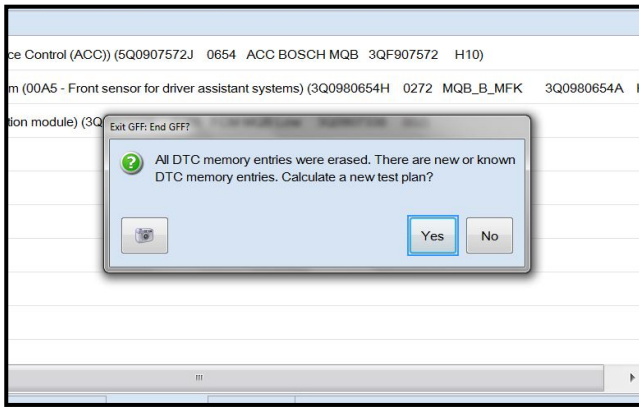

- Exit GFF and send diagnostic protocol online when prompted.

NOTE

Static communication faults may store in various control modules during the flash. These faults can only be cleared by following one of these steps:

- Drive the vehicle a short distance (around the parking lot, for example).
 - After selecting “Yes”, turn the ignition off for 30 seconds, turn it back on and repeat the GFF exit program.
 - Clear faults using OBD (an additional key cycle may also be required).
- Release the parking brake.
 - Disconnect the VAS tester.
 - Remove the SD card from the 5F module.
 - Switch off and disconnect the battery charger.
 - Reinstall the battery cover.

Proceed to Section E

Section D – Replace Instrument Cluster

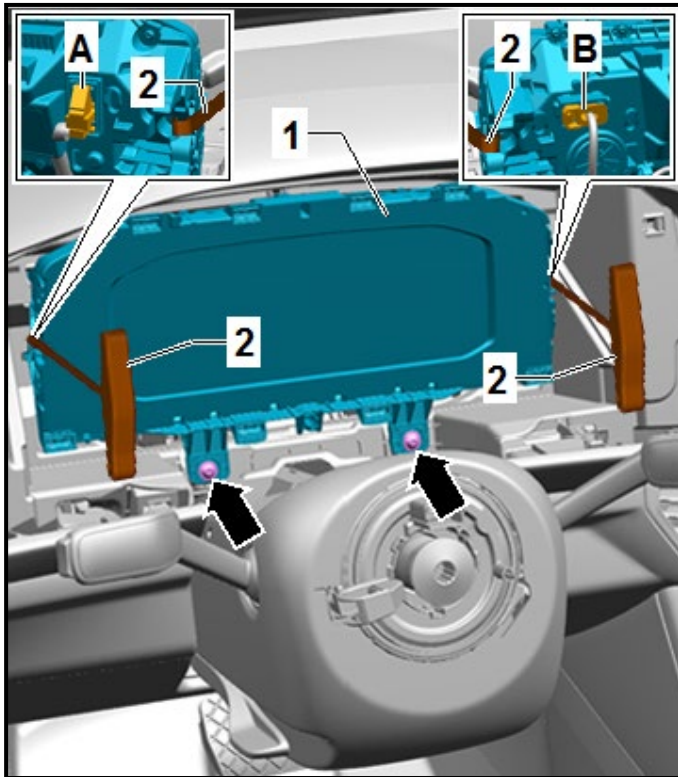

Replace the instrument cluster according to the ELSA repair manual:

- *Repair manual > Electrical System > Electrical Equipment > 90 Instruments > Instrument cluster > Instrument Cluster KX2, Removing and Installing > Instrument Cluster KX2, Removing and Installing, All-Digital Instrument Cluster.*

Proceed to section E

Section E – Campaign Completion Label

Install Campaign Completion Label

- Fill out and affix Campaign Completion Label, part number CAMP 010 000, next to the vehicle emission control information label.



TIP

Ensure Campaign Completion Label does not cover any existing label(s).

Proceed to Section F

Section F - Parts Return/Disposal

Properly store (retain), destroy or dispose of removed parts in accordance with all state/province and local requirements, unless otherwise indicated and/or requested through the Warranty Parts Portal (WPP) for U.S. and the Part Destruction and Core Disposition Report for Canada.