



Technical Service Bulletin

93 e-tron GE electric drive motor leak P0AA600

93 24 25 2073858/3 October 24, 2024. Supersedes Technical Service Bulletin Group 93 number 24-22 dated October 8, 2024 for reasons listed below.

Model(s)	Year	VIN Range	Vehicle-Specific Equipment
e-tron	2019 2021 – 2023	All	Not Applicable
e-tron Sportback	2020 – 2023		
Q8 e-tron, Q8 Sportback e-tron, SQ8 e-tron, and SQ8 Sportback e-tron	2024		

REVISION HISTORY		
Revision	Date	Purpose
3	-	Revised <i>Service</i> (Removed AKT instructions) Revised <i>Warranty</i> (Updated labor operations)
2	10/08/2024	Revised <i>Warranty</i> (Updated labor operation description) Revised <i>Service</i> (Updated documentation location)
1	07/27/2024	Initial publication

Customer states:

- A Drive System/Electrical System Malfunction message (Figure 1) appears in the in the instrument cluster; the warning may not be present at the time of inspection.



Figure 1. Warning lamp associated with message.

Workshop findings:



Technical Service Bulletin

The following DTC and symptom code may be stored in *the Battery manager control module -J840-*, (address word 008C):

- Hybrid/EV Battery Voltage System Isolation.

and/or

- During a workshop visit, an internal leak (e.g., coolant drip container is full; coolant leaking from active chamber on front or rear axle) has been determined on the electric drive motor.

Technical Background 1

Electric drive motor damaged due to internal coolant leak.

Production Solution

Not applicable.

Service

Check coolant leak and localize the source of the leak:

Special Technical Service Training from April 2023 can be used as reference; you can find the document in the attachments.

Only if the following information is given can it be assumed that the **electric drive motor is damaged due to an internal coolant leak:**



In this case, check the seal on the coolant expansion tank beforehand and re-secure it after performing any required work. Vehicles should never be operated without a correctly filled cooling system.

Rear axle (Figure 2):

Drip container is overflowing:

- Coolant leaking from active chamber.

Drip container is empty:

- Coolant leaking from active chamber, particularly on vehicles with low mileage.



Technical Service Bulletin

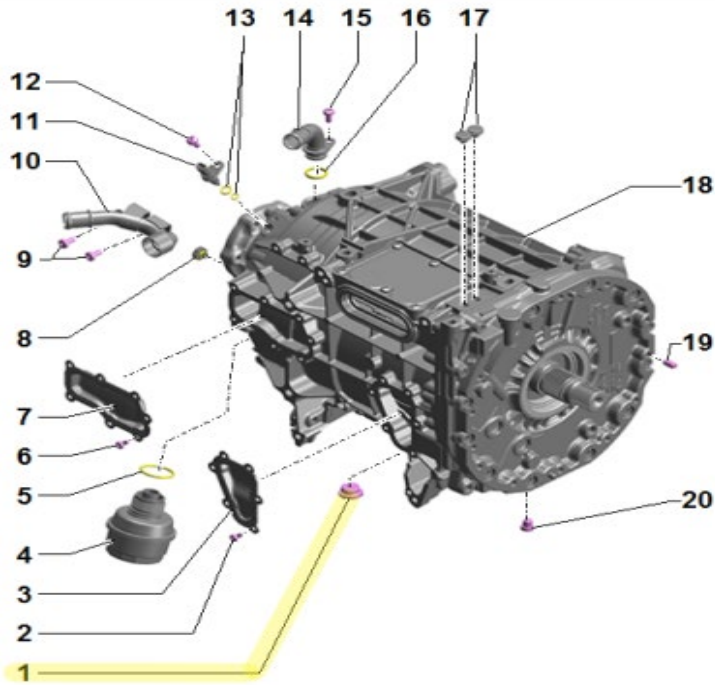

Figure 2: (1) Drain plug.

Front axle (Figure 3):

Coolant leaking from active chamber.

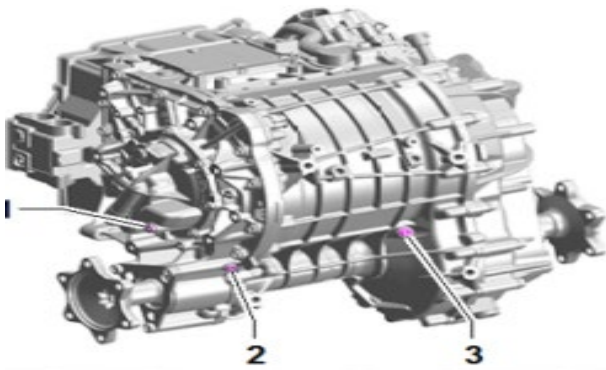

Figure 3: 1) Resolver cover: A few milliliters of coolant leakage is not an issue from a technical perspective. 2) Active chamber: No coolant may escape from the bores.

The power electronics for electric drive must not necessarily be replaced if the electric drive motor is leaking (refer to images 4 and 5).

In this case, the power and control electronics for electric drive must not be replaced.



Technical Service Bulletin

1) Corrosion on the high-voltage system connection for power and control electronics for electric drive (Figure 4).



Figure 4: Corrosion on high-voltage system connection for power and control electronics for electric drive.

2) Condensation on high-voltage system connection cover (Figure 5).



Figure 5: Condensation on high-voltage system connection cover.



If the power and control electronics for electric drive must be replaced as a group, then this must be billed separately (see warranty accounting instructions).

Warranty

Claim Type:	<ul style="list-style-type: none">If the vehicle is outside of any warranty, this Technical Service Bulletin is informational only.
Service Number:	9340 (If front electric drive motor was replaced)
Damage Code:	0050
OR	
Service Number:	9346 (If rear electric drive motor was replaced)



Technical Service Bulletin

Damage Code:	0050		
OR			
Service Number:	9350 (If the power and control electronics for electric drive were replaced; this must be billed separately)		
Damage Code:	T055		
Labor Operations:	Check electric drive motor for front axle for leaks	9340 0199	Bill according to time required
	Check electric drive motor for rear axle for leaks	9346 0199	Bill according to time required
	Replace front drive motor	9340 55xx	See SRT with associated operations
	Replace electric drive motor for rear axle	9346 55xx	See SRT with associated operations
	Replace 2 electric drive motors for rear axle, e-tron S	9346 56xx	See SRT with associated operations
	Replace front power and control electronics for electric drive	9350 5599	80 TU
	Replace rear power and control electronics for electric drive	9350 5599	80 TU
	Replace 2 rear power and control electronics for electric drive, e-tron S	9350 5699	110 TU
	Charge battery	2706 8950	See SRT with associated operations
	GFF	0150 0060	Time stated on the diagnostic protocol
	Test drive before the service procedure	No Allowance	0 TU
Test drive after the service procedure	0121 0004	10 TU	
Claim Comment:	As per TSB 2073858/3		

All warranty claims submitted for payment must be in accordance with the *Audi Warranty Policies and Procedures Manual*. Claims are subject to review or audit by Audi Warranty.



Technical Service Bulletin

Required Parts and Tools

Always check with your Parts Department and/or ETKA for the latest information and parts bulletins.		
Part Number	Part Description	Quantity
See ETKA	Fasteners, Bolts, Nuts, and Screws as needed per the Repair Manual	See ETKA/ELSA
See ETKA	Front drive motor	01
See ETKA	Rear drive motor	01
See ETKA	Rear drive motors e-tron S	02
See ETKA	Front drive motor power electronics	01
See ETKA	Rear drive motor power electronics	01
See ETKA	Rear drive motor power electronics	02

Additional Information

All parts and service references provided in this TSB (2073858) are subject to change and/or removal.

©2024 Audi of America, Inc. All rights reserved. The information contained in this document is based on the latest information available at the time of printing and is subject to the copyright and other intellectual property rights of Audi of America, Inc., its affiliated companies, and its licensors. All rights are reserved to make changes at any time without notice. No part of this document may be reproduced, stored in a retrieval system, or transmitted in any form or by any means, electronic, mechanical, photocopying, recording, or otherwise, nor may these materials be modified or reposted to other sites without the prior expressed written permission of the publisher.