

NON-COMPLIANCE RECALL

Mack Trucks Inc.
Greensboro, NC USA



Date	Number	Release	Page
05.2024	EC0032	02	1(6)

M0310 SCR Replacement MP8 VGT (One Box) AN, CHU, CXU, GR, GU, and PI

RECALL INFORMATION

Revised 10/25/2024 Gasket 22677399 Changed to 21376801

(May 2024)

Mack Trucks has identified that the Selective Catalyst Reduction (SCR) system in certain vehicles equipped with the MY 2017 or 2018 MP8 (13L VGT) engine are not meeting California and EPA emissions standards, or Mack cannot confirm its compliance. These vehicles have been flagged due to telematics data showing that the NOx conversion efficiency of the SCR system has dropped below 94% for eight weeks. Alternatively, these vehicles may have communication issues with telematics, such as not reporting or ceasing reporting for the same period.

To ensure Mack remains emission compliant on these vehicles, follow the repair instructions outlined in this document to replace the Selective Catalyst Reduction (SCR) system with new one.

VEHICLES AFFECTED

Certain Mack vehicles manufactured between September 6, 2016, and December 21, 2018.

VEHICLE QUANTITY

This Vin list will be dynamic, VIN's will be added to the VIN list in 8-week cycles based on monitoring from Recall M0303.

Parts Information

The SCR Muffler should be ordered VOR, all other parts should be ordered through normal process.

Part Number	Description	Quantity
23160669	SCR Muffler	1
23108406	Clamping band kit	1
21376801	Gasket	1
990413	Screw	3
21095726	Gasket	3
21095721	Gasket	1

Important Parts Note!

Please dispose of the SCR Muffler following the normal process.

Repair Instructions

Important Service Note!

Before replacing the SCR Muffler under this recall, you must verify that **M0303 Software Recall** has been completed. If **M0303 Software Recall** has not been completed, it must be done first.

1. Park the vehicle on a level surface.
2. Apply the parking brake.
3. Place the gear lever in neutral.
4. Install wheel chocks.

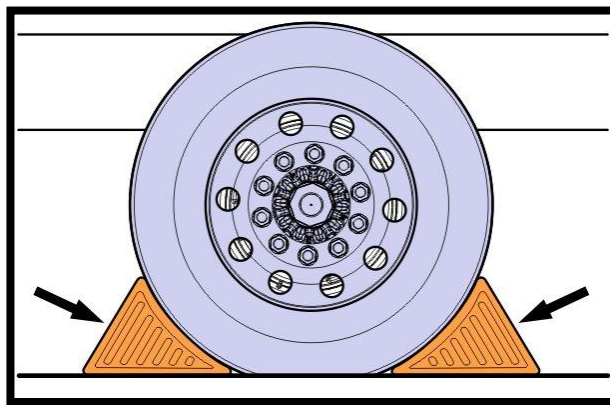

5. Follow Impact operation **2586-03-02-10 Muffler, Replacement (Combined DOC, DPF, SCR) Decontented** to replace the SCR with a new SCR muffler.
6. Install and fill out the Campaign Completion Label if needed.
7. Remove the wheel chocks.

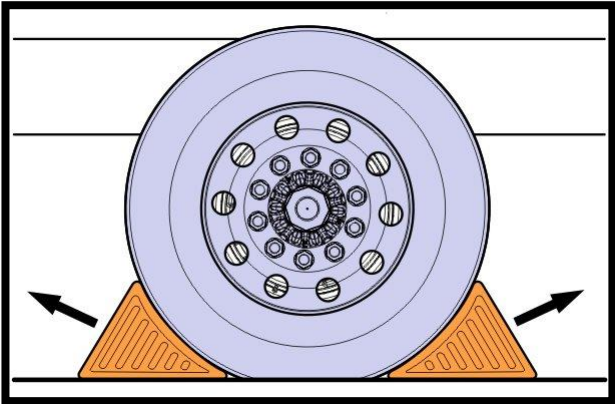

8. Release truck to customer.

Important Note!

If needed, print out this Emission Recall Proof of Correction Certificate. Fill in the appropriate information for your records and provide a copy to the customer.

Vehicle Emissions Recall - Proof of Correction

License Number	Make	Year Model	Year Model	Vehicle Identification Number

Manufacturer: _____ Recall Number: _____

The above described vehicle has been repaired, modified to address the Emissions Related Recall that is listed above.

Dealer's _____ Address, City, State _____

Dealer's Authorized Signature _____

X _____

Return this certificate to DMV only when required - otherwise retain for your records.

REIMBURSEMENT

This repair is covered by an authorized Non-Compliance recall. Reimbursement is obtained through the normal claim handling process.	
	UCHP Reimbursement
Claim Type (used only when uploading from the Dealer Business System)	40
Recall Status	
Vehicle repaired per instructions	1-Modified per instructions
Labor code	
2586-03-02-10 Muffler, Replacement (Combined DOC, DPF, SCR) Decontented	Use Impact
Causal Part	21970120
Authorization Number	M0310

Note: Dealers are to perform Non-Compliance Recall on all subject vehicles at no charge to the vehicle owner regardless of mileage, age of vehicle or ownership (original purchaser or subsequent purchasers). Whenever vehicles are subject to a Non-Compliance Recall are brought to your dealership for service, or taken into your dealership vehicle inventory, it is strongly recommended that every effort be made to perform the recall correction before the vehicle is sold or released to the owner.