

# Service Alert

Mazda North American Operations  
Irvine, CA 92618-2922



<b>Subject:</b>  NEW CYLINDER HEAD ASSEMBLY ESTABLISHED	<b>Service Alert No.:</b> SA-073/24
	<b>Last Issued :</b> 10/01/2024

## BULLETIN NOTES

This service alert supersedes the previously issued service alert listed below. The changes are noted in Red text.

Previous SAs:	Date(s) Issued:
SA-073/24	10/01/24
SA-037/23	8/16/23, 06/06/23
SA-013/22	03/16/22
SA-031/21	12/22/21, 10/15/21, 08/05/21 and 05/06/21
SA-058/20	12/21/20, 08/20/20, 08/05/20 and 7/24/20

Dealers can now utilize the Limited Parts Ordering (LPO) page on eMDCS to order the repair parts for 2.5L (with cylinder deactivation). Hotline and MASH authorization is not required to order parts for performing this repair. If there are any questions on part ordering or part status, contact the DAG group for assistance.

## APPLICABLE MODEL(S)/VINS

- 2018-2023 CX-5 2.5 SKYACTIV G with cylinder deactivation only (US spec)
- 2018-2021 Mazda6 2.5 SKYACTIV G with cylinder deactivation only (US spec)
- 2019-2023 Mazda3 2.5 SKYACTIV G with cylinder deactivation only (US spec)
- 2020-2023 CX-30 2.5 SKYACTIV G with cylinder deactivation only (US spec)

## DESCRIPTION

A new cylinder head assembly for service parts has been newly established for SKYACTIV-G 2.5 with cylinder deactivation when replacement is needed. Valves, valve springs, valve spring seats, and cotters (IN/EX) are included in the new assembly.

**Hotline and MASH authorization is not required to order parts for performing this repair. If there are any questions on part ordering or part status, contact the Dealer Assistance Group.**

Searching Key Words: Cam Journal, Valve Guide, Intake Valve, Exhaust Valve, Valve Spring, Hydraulic Lifter, Coolant leak, Coolant smell, Warp head, Engine Oil Leak, Oil Smell, Oil leak, Misfire, Low Compression, Excessive Leak Down, Burnt Valves, Rocker Arm.

**CONSUMER NOTICE:** The information and instructions in this bulletin are intended for use by skilled technicians. Mazda technicians utilize the proper tools/ equipment and take training to correctly and safely maintain Mazda vehicles. These instructions should not be performed by "do-it-yourselfers." Customers should not assume this bulletin applies to their vehicle or that their vehicle will develop the described concern. To determine if the information applies, customers should contact their nearest authorized Mazda dealership. Mazda North American Operations reserves the right to alter the specifications and contents of this bulletin without obligation or advance notice. All rights reserved. No part of this bulletin may be reproduced in any form or by any means, electronic or mechanical---including photocopying and recording and the use of any kind of information storage and retrieval system ---without permission in writing.

## REPAIR PROCEDURE

**CAUTION:** Inspect the replacement cylinder head for scratches, damage, and proper valve keeper installation before installing the head. Photograph and contact Hotline if any problems are found.

Several videos have been created to aid with the cylinder head replacement

[VIDEO REVIEW IS REQUIRED BEFORE PROCEEDING WITH HEAD REPLACEMENT \(Videos can be found under the Related Content tab or linked below\).](#)

**NOTE:** Videos are for reference only. Refer to the instructions on MGSS for more detail.

**CAUTION:** Care should be taken when handling the wire harnesses. Bending or stretching the harnesses could break the wires and this type of damage is not covered under warranty.

- SKYACTIV-G Timing Chain Replacement
- Camshaft Inspection
- Cylinder Inspection
- Bolt Hole Prep
- SHLA Installation
- Fuel Injector Seal Replacement
- Cylinder Head Bolt measuring Technique

**CAUTION:** Remove both heat shields from the exhaust manifold to thoroughly clean the exhaust manifold and shields of oil and debris.

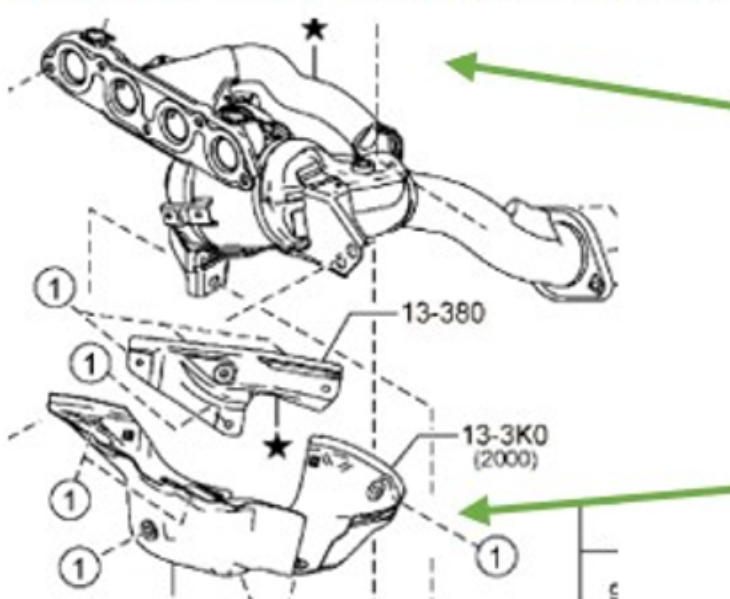

**CONSUMER NOTICE:** The information and instructions in this bulletin are intended for use by skilled technicians. Mazda technicians utilize the proper tools/ equipment and take training to correctly and safely maintain Mazda vehicles. These instructions should not be performed by "do-it-yourselfers." Customers should not assume this bulletin applies to their vehicle or that their vehicle will develop the described concern. To determine if the information applies, customers should contact their nearest authorized Mazda dealership. Mazda North American Operations reserves the right to alter the specifications and contents of this bulletin without obligation or advance notice. All rights reserved. No part of this bulletin may be reproduced in any form or by any means, electronic or mechanical---including photocopying and recording and the use of any kind of information storage and retrieval system ---without permission in writing.

**PARTS INFORMATION**

Cylinder Head Part Number (PYUD)	Part Name	Part Number	Component Part Number	Component
PYY4-10-SJ0  PYUD Cylinder Head (W/Cylinder Deactivation)	GASKET KIT A FOR CYL HEAD (PYUD)	PYY2-10-S50	PYFA-10-193	Gasket R
			PYFA-10-235	Gasket He
			PE01-10-673	O-R
			P54G-10-673	O-Ring (For 2020-2022 C)
			PYFA-10-673	O-F
			PE01-13-555	Rubbe
			PYFA-15-159A	Gasket Wa
			PE01-15-165	Gasket Wate
			PE01-15-287	O-Ring, Wa
			PE01-20-ZF1	O-F
	GASKET KIT B FOR CYL HEAD (PYUD)	PYY2-13-S50	PYFA-13-252	Grommet (T
			PE02-13-252	Grommet
			PY01-13-252	Grommet (S
			PYFA-13-253	O-F
			PYFA-15-591A	O-Ring, W
			9YB1-01-006	Nut
			9YA0-20-678	Bo
			9YA0-20-865	Bo
	GASKET KIT C FOR CYL HEAD (PYUD)	PYY2-13-SRZ	ZJ01-10-243	Washer
			PY01-10-271	Gasket Cli
			PE01-10-602	Sea
			PE01-12-257	O-F
			PY01-13-111	Gasket Inle
			PYMM-13-290A	Pipe
			PE01-13-655	Gasket Thr
			PYFA-15-169A	Gasket Wa
			9956-41-400	Gas
			PY01-13-460	Gasket Exha
			PYFB-15-169	Gasket Wa

**CONSUMER NOTICE:** The information and instructions in this bulletin are intended for use by skilled technicians. Mazda technicians utilize the proper tools/ equipment and take training to correctly and safely maintain Mazda vehicles. These instructions should not be performed by "do-it-yourselfers." Customers should not assume this bulletin applies to their vehicle or that their vehicle will develop the described concern. To determine if the information applies, customers should contact their nearest authorized Mazda dealership. Mazda North American Operations reserves the right to alter the specifications and contents of this bulletin without obligation or advance notice. All rights reserved. No part of this bulletin may be reproduced in any form or by any means, electronic or mechanical--including photocopying and recording and the use of any kind of information storage and retrieval system ---without permission in writing.

	GASKET KIT D FOR CYL H EAD (PYUD)	PYY2-13-W8Z	PE02-18-T41	O-Ring (
			PE23-40-305	Ex. Pipe Fla
			PE13-15-296	Conn
			9994-61-000	Ex. Pipe F

**NOTE:**

- All kits A-D will need to be ordered when replacing one cylinder head
- Cylinder head bolts will no longer be supplied with the Cylinder head parts kit.
- Head bolts must be *measured and re-used* if within the specification in MGSS
- Refer to the "Cylinder head bolt measuring technique" video under the Related content tab for proper head bolt measuring.

**WARRANTY INFORMATION**

Reference [Warranty Policy 3.28 MASH Authorization for Warranty Repairs](#) to confirm whether MASH is required or not.

**CONSUMER NOTICE:** The information and instructions in this bulletin are intended for use by skilled technicians. Mazda technicians utilize the proper tools/ equipment and take training to correctly and safely maintain Mazda vehicles. These instructions should not be performed by "do-it-yourselfers." Customers should not assume this bulletin applies to their vehicle or that their vehicle will develop the described concern. To determine if the information applies, customers should contact their nearest authorized Mazda dealership. Mazda North American Operations reserves the right to alter the specifications and contents of this bulletin without obligation or advance notice. All rights reserved. No part of this bulletin may be reproduced in any form or by any means, electronic or mechanical---including photocopying and recording and the use of any kind of information storage and retrieval system ---without permission in writing.