

Technical Service Bulletin

Mazda North American Operations
Irvine, CA 92618-2922



| | |
|---|---------------------------------|
| Subject: REAR CONSOLE LID DOES NOT SLIDE SMOOTHLY | Bulletin No.: 09-042/24 |
| | Last Issued : 10/02/2024 |

BULLETIN NOTES

This bulletin supersedes the previously issued bulletin(s) listed below. The changes are noted in Red.

| Previous TSBs: | Date(s) Issued: |
|----------------|-----------------------|
| 09-042/24 | 08/30/24 |
| 09-016/22 | 04/29/22 and 10/19/22 |
| 09-024/20 | 07/22/20 |

APPLICABLE MODEL(S)/VINS

2019-2023 Mazda3 (Japan built) vehicles with VINs lower than JM1 BP**** ** 623994 (Produced before Mar. 27, 2023)
2019-2023 Mazda3 (Mexico built) vehicles with VINs lower than 3MZ BP**** ** 385903 (Produced before Sep. 11, 2023)
2020-2025 CX-30

DESCRIPTION

Some customers may complain that the rear console lid does not slide smoothly. This may be caused by improperly positioned felt pads attached to the rear console lid lock, which may have moved out of position after repetitive use. The exposed adhesive residue may stick to the rail and disrupt smooth sliding operation.



To eliminate this concern, the felt pad positions have been changed.

CONSUMER NOTICE: The information and instructions in this bulletin are intended for use by skilled technicians. Mazda technicians utilize the proper tools/ equipment and take training to correctly and safely maintain Mazda vehicles. These instructions should not be performed by "do-it-yourselfers." Customers should not assume this bulletin applies to their vehicle or that their vehicle will develop the described concern. To determine if the information applies, customers should contact their nearest authorized Mazda dealership. Mazda North American Operations reserves the right to alter the specifications and contents of this bulletin without obligation or advance notice. All rights reserved. No part of this bulletin may be reproduced in any form or by any means, electronic or mechanical---including photocopying and recording and the use of any kind of information storage and retrieval system ---without permission in writing.

NOTE: Mazda3 rear console lid has been modified.

Customers having this concern should have their vehicle repaired using the following repair procedure.

CONSUMER NOTICE: The information and instructions in this bulletin are intended for use by skilled technicians. Mazda technicians utilize the proper tools/ equipment and take training to correctly and safely maintain Mazda vehicles. These instructions should not be performed by "do-it-yourselfers." Customers should not assume this bulletin applies to their vehicle or that their vehicle will develop the described concern. To determine if the information applies, customers should contact their nearest authorized Mazda dealership. Mazda North American Operations reserves the right to alter the specifications and contents of this bulletin without obligation or advance notice. All rights reserved. No part of this bulletin may be reproduced in any form or by any means, electronic or mechanical---including photocopying and recording and the use of any kind of information storage and retrieval system ---without permission in writing.

REPAIR PROCEDURE

2019-2022 Mazda3 Only: Be advised that a related TSB (09-043/24 REAR CONSOLE LID DOES STICKING AND SQUEAKING WHEN OPENING AND/OR CLOSING) is available if additional repairs are necessary to resolve the customer complaint.

Verify the subject vehicle is within one of the VIN ranges shown below:

- 2019-2022 Mazda3 (Japan built) with VINS lower than JM1BP*****510095 (produced before December 22, 2021)
- 2019-2022 Mazda3 (Mexico built) with VINS lower than 3MZBP*****220473 (produced before December 22, 2021)

If the subject vehicle is applicable, complete the service bulletin repair by replacing the hinge pin with an improved part (shape of hinge pin has been modified) in addition to replacing the felt pads outlined in the repair procedure below.

1. Verify the customer concern.
2. Open the lid and remove the felt pads (1) glued onto the locks, as shown below.

NOTE: The white arrow indicates the front side.

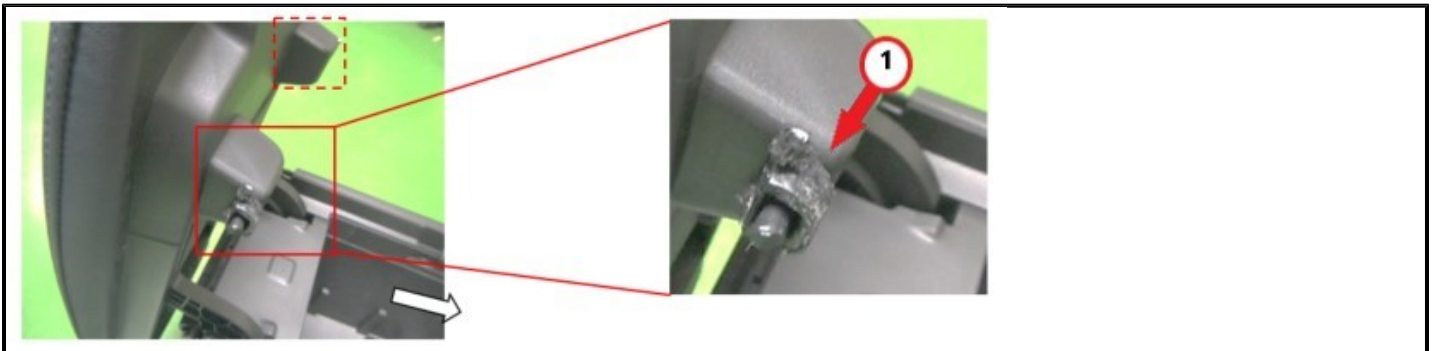

3. Remove all adhesive residue from the locks and rails (upper and lower faces).

CAUTION: Before removing the residue, verify the adhesive cleaning product will not damage the parts to be cleaned. Refer to the materials (1 - 6) list below.

CONSUMER NOTICE: The information and instructions in this bulletin are intended for use by skilled technicians. Mazda technicians utilize the proper tools/ equipment and take training to correctly and safely maintain Mazda vehicles. These instructions should not be performed by "do-it-yourselfers." Customers should not assume this bulletin applies to their vehicle or that their vehicle will develop the described concern. To determine if the information applies, customers should contact their nearest authorized Mazda dealership. Mazda North American Operations reserves the right to alter the specifications and contents of this bulletin without obligation or advance notice. All rights reserved. No part of this bulletin may be reproduced in any form or by any means, electronic or mechanical---including photocopying and recording and the use of any kind of information storage and retrieval system ---without permission in writing.

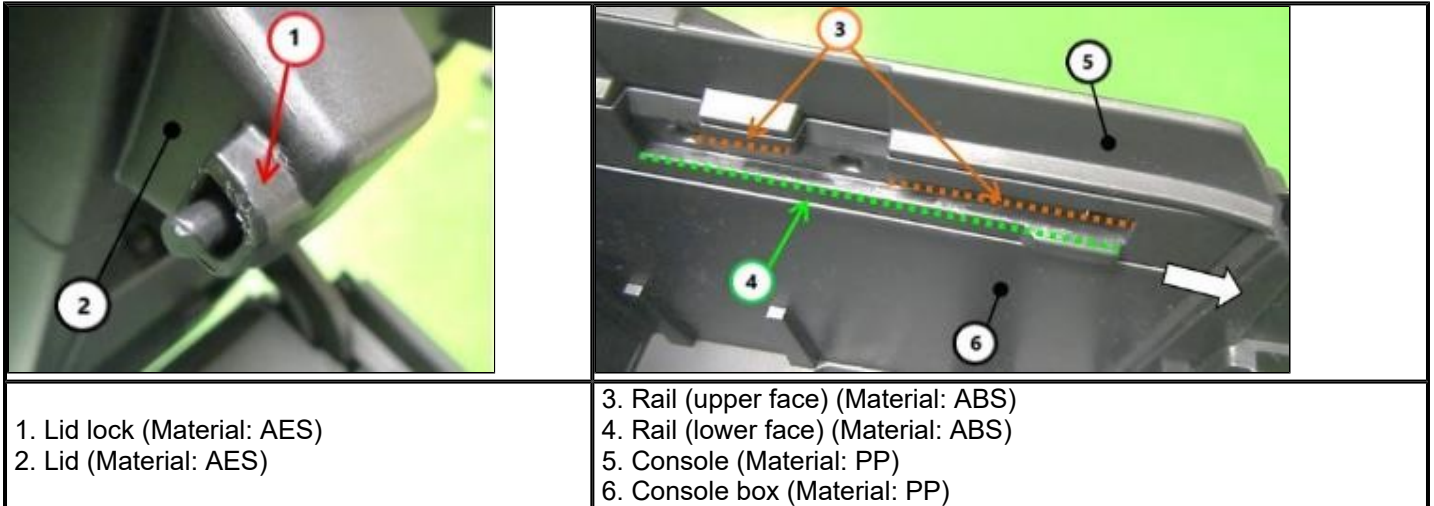

4. After removing all adhesive residue, clean the area using a clean cloth, then confirm the rails (upper and lower faces) are smooth.

CONSUMER NOTICE: The information and instructions in this bulletin are intended for use by skilled technicians. Mazda technicians utilize the proper tools/ equipment and take training to correctly and safely maintain Mazda vehicles. These instructions should not be performed by "do-it-yourselfers." Customers should not assume this bulletin applies to their vehicle or that their vehicle will develop the described concern. To determine if the information applies, customers should contact their nearest authorized Mazda dealership. Mazda North American Operations reserves the right to alter the specifications and contents of this bulletin without obligation or advance notice. All rights reserved. No part of this bulletin may be reproduced in any form or by any means, electronic or mechanical---including photocopying and recording and the use of any kind of information storage and retrieval system ---without permission in writing.

5. Apply the modified felt pads according to the following steps.

- [Mazda3] Cut off .79cm (0.31 inch) (1) from both ends of the felt pads.
- [CX-30] Go to step 6

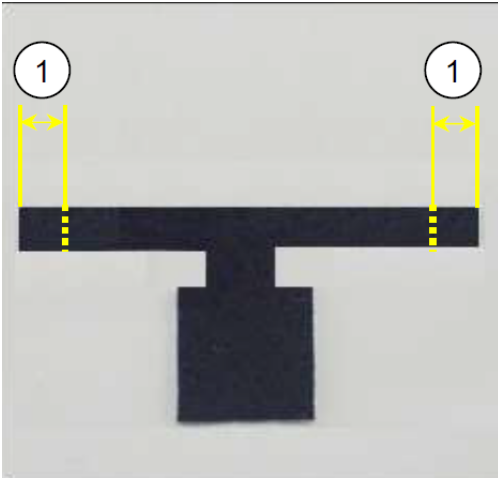

6. Peel off the release papers and apply the felt pads (2) on the lock parts (1) of the console lid.

NOTE:

- Align the lid shaft center (3) and the center line of the felt pad (4).
- Align the edge of the lid and the edge of the felt pad (5).

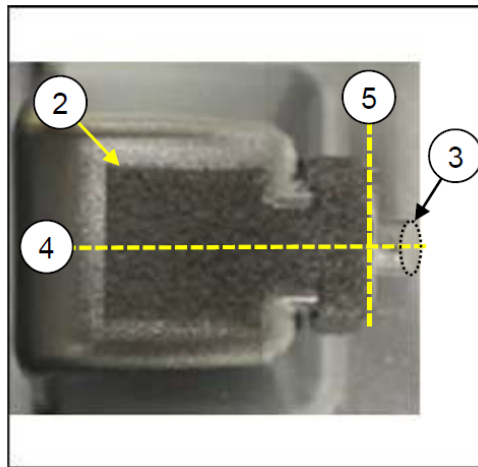
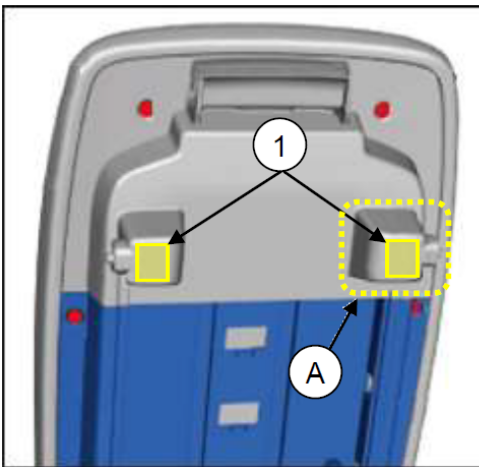

CONSUMER NOTICE: The information and instructions in this bulletin are intended for use by skilled technicians. Mazda technicians utilize the proper tools/ equipment and take training to correctly and safely maintain Mazda vehicles. These instructions should not be performed by "do-it-yourselfers." Customers should not assume this bulletin applies to their vehicle or that their vehicle will develop the described concern. To determine if the information applies, customers should contact their nearest authorized Mazda dealership. Mazda North American Operations reserves the right to alter the specifications and contents of this bulletin without obligation or advance notice. All rights reserved. No part of this bulletin may be reproduced in any form or by any means, electronic or mechanical--including photocopying and recording and the use of any kind of information storage and retrieval system ---without permission in writing.

- Complete image to apply the modified felt pad (1) (view from the lid-shaft (2))

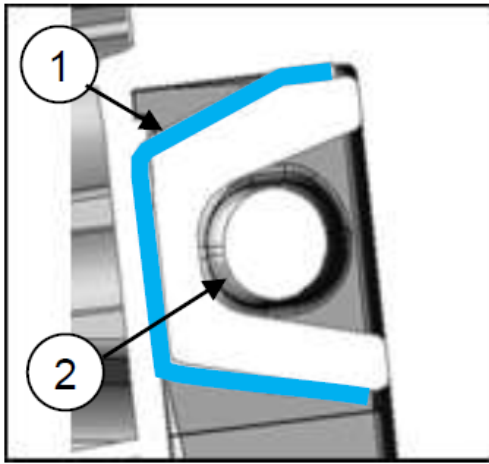

Mazda3

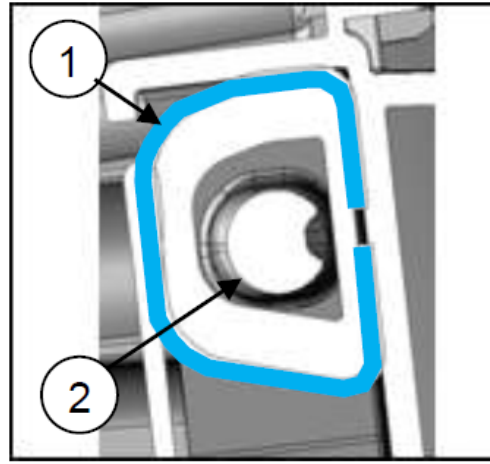

CX-30

7. Verify the repair by sliding the console lid several times.

PARTS INFORMATION

| Parts Number | Description | Qty. | Notes |
|--------------|-------------|------|------------------|
| DFY0-55-180 | Spacer Set | 1 | Felt Pad, 2 pcs. |

CONSUMER NOTICE: The information and instructions in this bulletin are intended for use by skilled technicians. Mazda technicians utilize the proper tools/ equipment and take training to correctly and safely maintain Mazda vehicles. These instructions should not be performed by "do-it-yourselfers." Customers should not assume this bulletin applies to their vehicle or that their vehicle will develop the described concern. To determine if the information applies, customers should contact their nearest authorized Mazda dealership. Mazda North American Operations reserves the right to alter the specifications and contents of this bulletin without obligation or advance notice. All rights reserved. No part of this bulletin may be reproduced in any form or by any means, electronic or mechanical---including photocopying and recording and the use of any kind of information storage and retrieval system ---without permission in writing.

WARRANTY INFORMATION**NOTE:**

- This warranty information applies only to verified customer complaints on vehicles eligible for warranty repair.
- This repair will be covered under Mazda's New Vehicle Limited Warranty term.
- Additional diagnostic time cannot be claimed for this repair.

| | |
|---------------------------------|---------------------|
| Warranty Type | A |
| Symptom Code | 72 |
| Damage Code | 9G |
| Part Number Main Cause | DFY0-55-180 |
| Quantity | 1 |
| Operation Number / Labor Hours: | XXS2PXRX / 0.3 Hrs. |

CONSUMER NOTICE: The information and instructions in this bulletin are intended for use by skilled technicians. Mazda technicians utilize the proper tools/ equipment and take training to correctly and safely maintain Mazda vehicles. These instructions should not be performed by "do-it-yourselfers." Customers should not assume this bulletin applies to their vehicle or that their vehicle will develop the described concern. To determine if the information applies, customers should contact their nearest authorized Mazda dealership. Mazda North American Operations reserves the right to alter the specifications and contents of this bulletin without obligation or advance notice. All rights reserved. No part of this bulletin may be reproduced in any form or by any means, electronic or mechanical---including photocopying and recording and the use of any kind of information storage and retrieval system ---without permission in writing.