

<b>Subject:</b>  <b>RATTLE NOISE FROM CENTER OF PANORAMA SUNROOF</b>	<b>Bulletin No.: 09-010/24</b>
	<b>Last Issued : 10/15/2024</b>

## BULLETIN NOTES

This bulletin supersedes the previously issued bulletin(s) listed below. The changes are noted in Red.

Previous TSBs:	Date(s) Issued:
09-010/24	02/07/24

## APPLICABLE MODEL(S)/VINS

2024 CX-90 with VINS lower than JM3KK\*\*\*\*\*158487 (produced before January 31, 2024)

## DESCRIPTION

Some vehicles may exhibit a rattle noise from the panorama sunroof. This may be caused by:

- Body vibration while driving and/or outside-temperature changes creating slight gaps between the plastic grommets and the roof reinforcement cover during use.
- A slight gap between the drip rail and the roof reinforcement, causing interference.

To eliminate this concern, the shape of the panorama sunroof unit will be modified.

**NOTE:** If the rattle noise is from rear end of the sunroof (the rear glass panel), refer to TSB 09-045/24 - RATTLE NOISE FROM REAR END OF PANORAMA SUNROOF WHILE DRIVING. This TSB is NOT applicable.

Customers having this concern should have their vehicle repaired using the following repair procedure.

## REPAIR PROCEDURE

1. Verify the customer concern.
2. Prepare non-woven felts into the following 2 sizes (Felt A, Felt B).

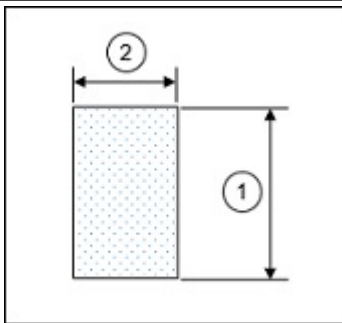
	<p><b>Felt A</b>                  Thickness: 0.02 in (0.5 mm)                  Cut the non-woven felt into the following size                  Length (1) : 0.5 +/- 0.04 in (13 +/- 1 mm)                  Width (2) : 0.2 +/- 0.04 in (5 +/- 1 mm)                  Quantities: 20 pcs.</p>
--	--

**CONSUMER NOTICE:** The information and instructions in this bulletin are intended for use by skilled technicians. Mazda technicians utilize the proper tools/ equipment and take training to correctly and safely maintain Mazda vehicles. These instructions should not be performed by "do-it-yourselfers." Customers should not assume this bulletin applies to their vehicle or that their vehicle will develop the described concern. To determine if the information applies, customers should contact their nearest authorized Mazda dealership. Mazda North American Operations reserves the right to alter the specifications and contents of this bulletin without obligation or advance notice. All rights reserved. No part of this bulletin may be reproduced in any form or by any means, electronic or mechanical--including photocopying and recording and the use of any kind of information storage and retrieval system ---without permission in writing.

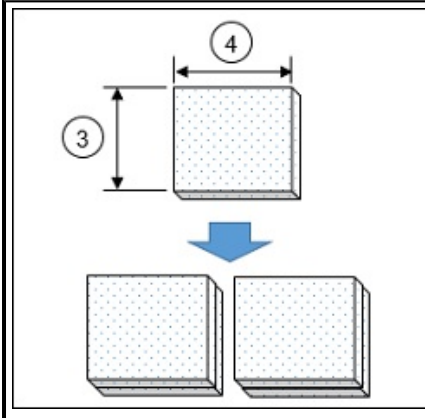
**Felt B**

1) Cut the the non-woven felt into the following size.

Thickness: 0.1 in (2.5 mm)

Length (3) : 0.6 +/- 0.04 in (15 +/- 1 mm)

Width (4) : 0.6 +/- 0.04 in (15 +/- 1 mm)

Quantities: 4 pcs.

2) Paste 2 pcs together to make two sets of the layers.

**NOTE:** DO NOT paste adhesive sides together.

3. Push the panorama sunroof switch and tilt the sunroof front glass panel (1) up until fully opened.

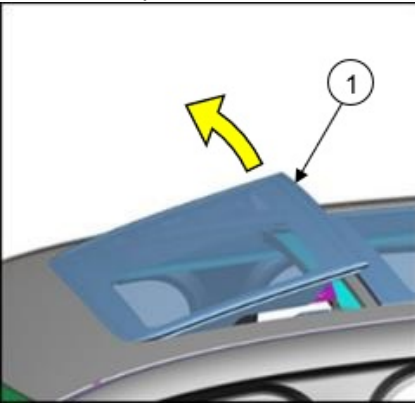

4. Remove the sunroof rear glass panel (1) according to the instructions in MGSS (SUNROOF REAR GLASS PANEL REMOVAL/INSTALLATION).

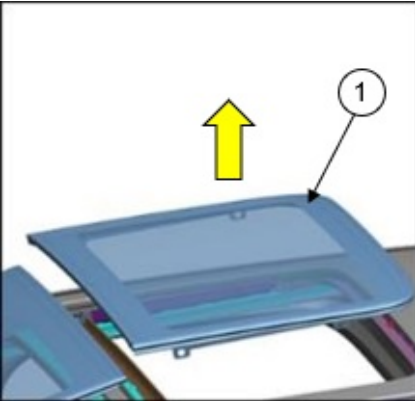

**CONSUMER NOTICE:** The information and instructions in this bulletin are intended for use by skilled technicians. Mazda technicians utilize the proper tools/ equipment and take training to correctly and safely maintain Mazda vehicles. These instructions should not be performed by "do-it-yourselfers." Customers should not assume this bulletin applies to their vehicle or that their vehicle will develop the described concern. To determine if the information applies, customers should contact their nearest authorized Mazda dealership. Mazda North American Operations reserves the right to alter the specifications and contents of this bulletin without obligation or advance notice. All rights reserved. No part of this bulletin may be reproduced in any form or by any means, electronic or mechanical---including photocopying and recording and the use of any kind of information storage and retrieval system ---without permission in writing.

5. Remove the plastic screw grommets (yellow circles).

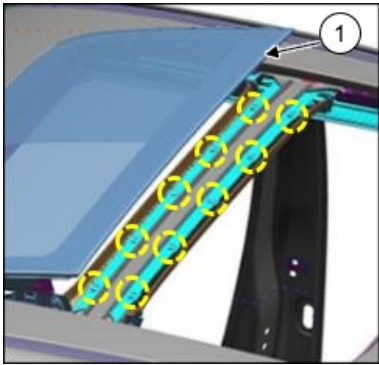

(1) Sunroof front glass panel Plastic screw grommet  
(10 pcs.)



Plastic screw grommet  
(10 pcs.)

6. Remove the roof reinforcement cover (1).

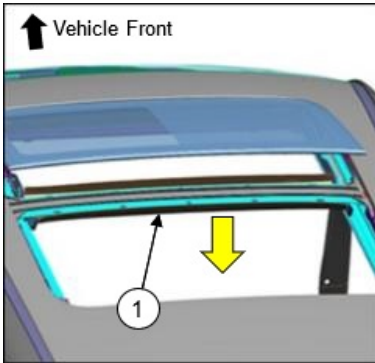

7. Apply Felt A (1) on the roof reinforcement cover (2) as per the following images.

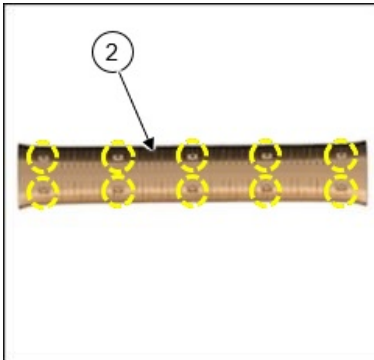

**Felt A location**  
(Roof reinforcement cover)

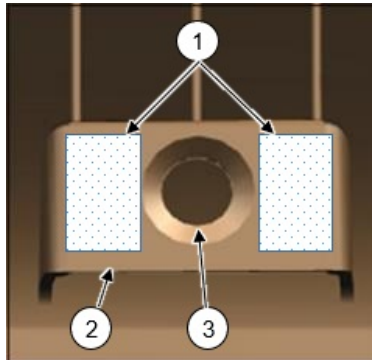

**Detail of the applying location**  
(1) Felt A  
(2) Roof reinforcement cover  
(3) Mounting hole

**CONSUMER NOTICE:** The information and instructions in this bulletin are intended for use by skilled technicians. Mazda technicians utilize the proper tools/ equipment and take training to correctly and safely maintain Mazda vehicles. These instructions should not be performed by "do-it-yourselfers." Customers should not assume this bulletin applies to their vehicle or that their vehicle will develop the described concern. To determine if the information applies, customers should contact their nearest authorized Mazda dealership. Mazda North American Operations reserves the right to alter the specifications and contents of this bulletin without obligation or advance notice. All rights reserved. No part of this bulletin may be reproduced in any form or by any means, electronic or mechanical--including photocopying and recording and the use of any kind of information storage and retrieval system ---without permission in writing.

8. Apply Felt B (1) into the gap between the drip rail (2) and the roof reinforcement (3) as per the following images.

**Position of applying Felt B:**

Insert Felt B (1) at yellow allows in the following image while avoiding cushioning materials on the roof reinforcement around the tab (5).

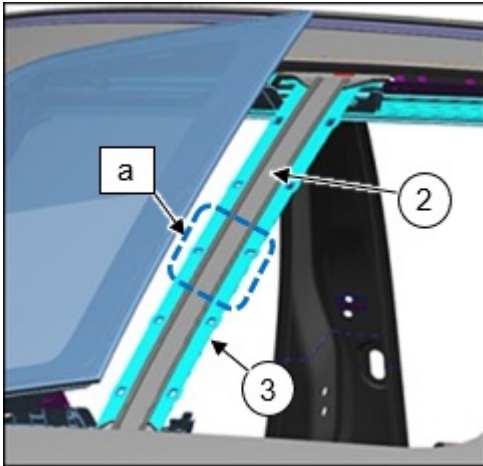

(2) Drip rail  
(3) Roof reinforcement Detail of a

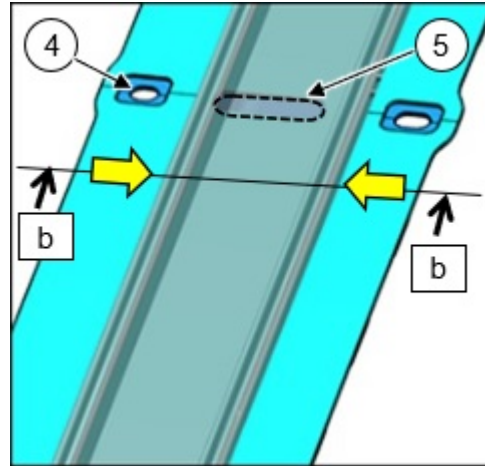

**Detail of a**  
(4) Center mounting hole  
(5) Tab (back side of the drip rail)

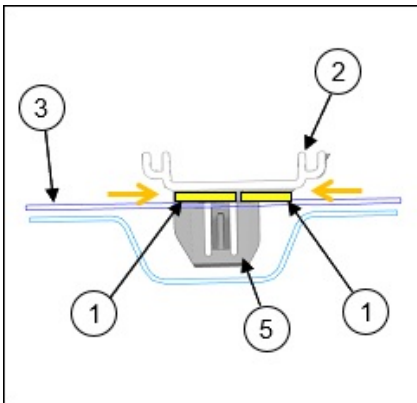

**Section b-b**

(1) Felt B  
(2) Drip rail  
(3) Roof reinforcement  
(5) Tab of the drip rail

9. Install the removed parts in reverse order of removal.

10. Verify the repair by making sure there is no rattle noise.

**CONSUMER NOTICE:** The information and instructions in this bulletin are intended for use by skilled technicians. Mazda technicians utilize the proper tools/ equipment and take training to correctly and safely maintain Mazda vehicles. These instructions should not be performed by "do-it-yourselfers." Customers should not assume this bulletin applies to their vehicle or that their vehicle will develop the described concern. To determine if the information applies, customers should contact their nearest authorized Mazda dealership. Mazda North American Operations reserves the right to alter the specifications and contents of this bulletin without obligation or advance notice. All rights reserved. No part of this bulletin may be reproduced in any form or by any means, electronic or mechanical--including photocopying and recording and the use of any kind of information storage and retrieval system ---without permission in writing.

**PARTS INFORMATION**

Parts Number	Description	Qty.	Notes
K001-W0-225	Int. Noise	1	Felt used in the repair (Q'ty included in the kit) 0.5 t x 50 x 250 mm (4 pcs.) 2.5 t x 300 x 240 mm (2 pcs.) <b>NOTE:</b> DO NOT throw the Noise Parts Kit away. It is considered a shop supply that repairs multiple vehicles for multiple issues and the cost is included in the Labor Time.

**WARRANTY INFORMATION****NOTE:**

- This warranty information applies only to verified customer complaints on vehicles eligible for warranty repair.
- This repair will be covered under Mazda's New Vehicle Limited Warranty term.
- Additional diagnostic time cannot be claimed for this repair.
- DO NOT throw the Noise Parts Kit away. It is considered a shop supply that repairs multiple vehicles for multiple issues and the cost is included in the Labor Time.

Warranty Type	A
Symptom Code	82
Damage Code	98
Part Number Main Cause	7777-SP-Y04
Quantity	0
Operation Number / Labor Hours:	XXWLBEAX / 3.2 Hrs.

**NOTE:** Int. Noise Kit is price is included in the Labor Hrs.

**CONSUMER NOTICE:** The information and instructions in this bulletin are intended for use by skilled technicians. Mazda technicians utilize the proper tools/ equipment and take training to correctly and safely maintain Mazda vehicles. These instructions should not be performed by "do-it-yourselfers." Customers should not assume this bulletin applies to their vehicle or that their vehicle will develop the described concern. To determine if the information applies, customers should contact their nearest authorized Mazda dealership. Mazda North American Operations reserves the right to alter the specifications and contents of this bulletin without obligation or advance notice. All rights reserved. No part of this bulletin may be reproduced in any form or by any means, electronic or mechanical--including photocopying and recording and the use of any kind of information storage and retrieval system ---without permission in writing.