



Maserati

PERSONAL SERVICE LAB

MASTERS OF CARE

Quattroporte - Dashboard Carbon Fiber Trim Anomalies

DATE: October 24, 2024

This Technical bulletin serves as a guide and provides additional information regarding warranty management of carbon fiber dashboard trims-related anomalies on Quattroporte vehicles only.

MODELS: M156 Quattroporte (From MY20 to MY24). Equip with OPT 04B DASHBOARD CARBON TRIMS

CUSTOMER CONCERN: cracks/deformation of the carbon fiber layer applied on the dashboard trims.

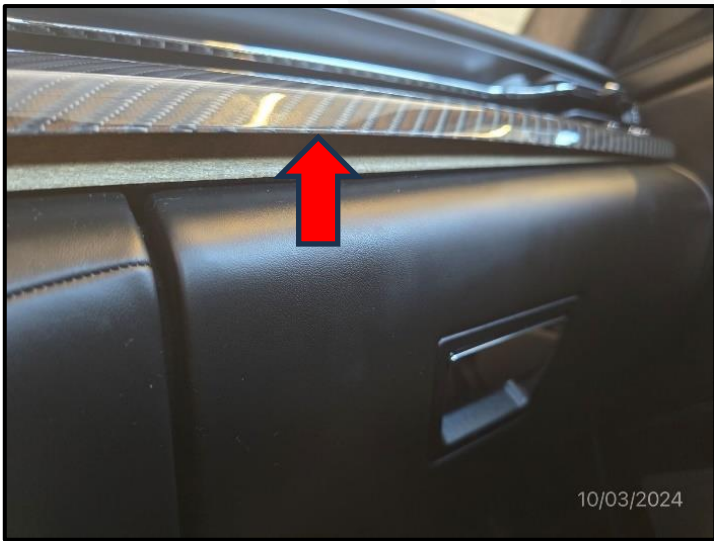

Example of deformation (surface separation)

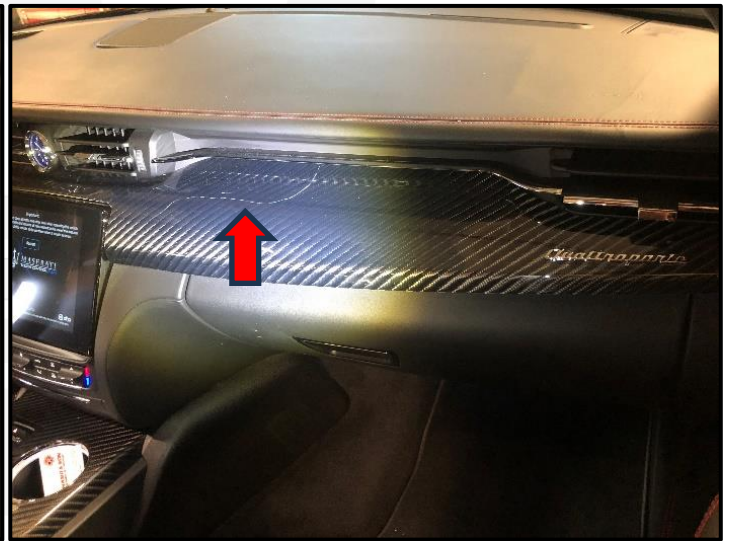

Example of crack

ACTIONS:

Maserati has recently updated its spare parts management for these components by separating the complete dashboard trim kit (P/Ns 673013156) into individual parts (components #52, 53, and 54 in the parts catalog) for Left-Hand Drive (LHD).

Following this change, any warranty replacements made after the release of this bulletin must be limited to the parts directly affected by the anomaly.

Example: Dashboard trim component #54 is cracked (NOT OK) but #53 and #52 are OK then only #54 should be replaced.

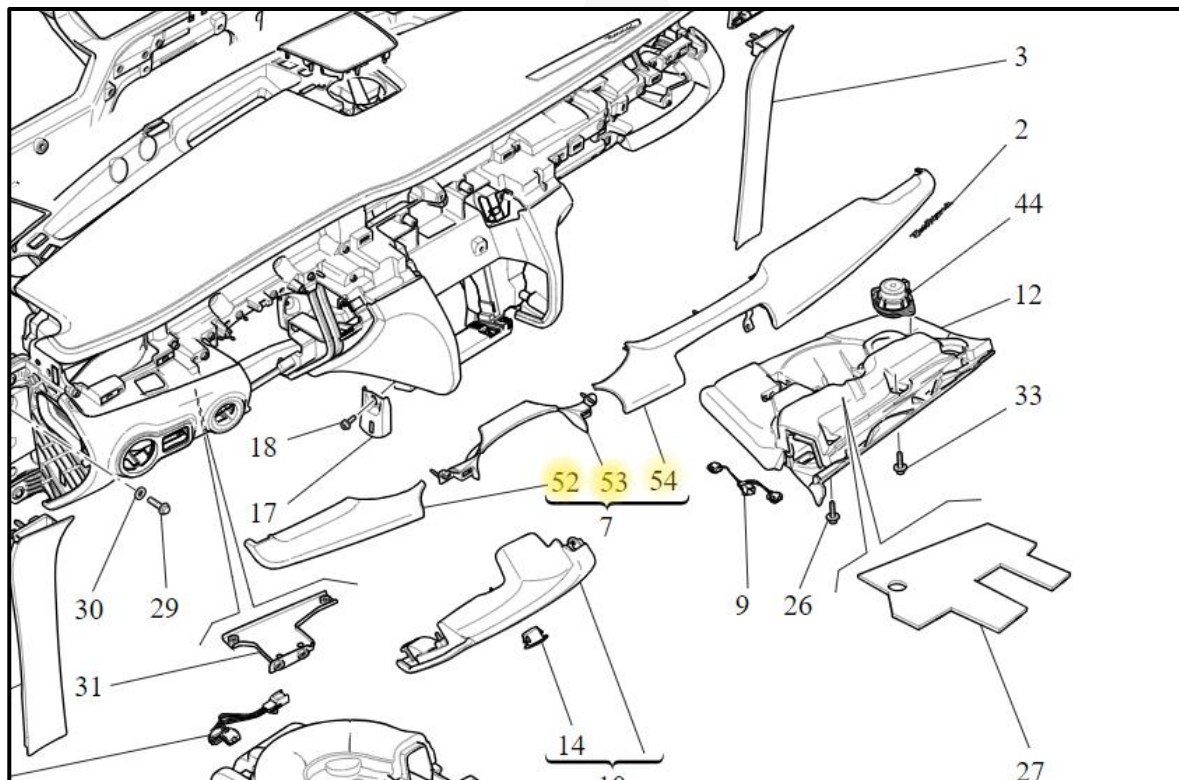

If multiple dashboard trim replacements are requested under warranty, a BOL must be submitted as a 'Request for Authorization.' The request must include CLEAR photos of the reported anomaly, with a visible 'sticky note' with the vehicle's VIN written on it.

Any warranty claims that do not meet the mentioned requirements cannot be approved and will be subject to review and possibly rejection.

We remain at your disposal for any clarification.

Kind regards,

TECHNICAL SERVICE OPERATIONS