



GROUP	MODEL
Voluntary Emissions Service Campaign	2021-2024MY K5 (DL3a) w/1.6L T-GDI
NUMBER	DATE
SC288 (Rev 4, 10/25/2024)	April 2024

VOLUNTARY EMISSIONS SERVICE CAMPAIGN

FUEL TANK AND/OR PCSV CHECK VALVE

Subject:

INSPECTION/REPLACEMENT + ECU SW UPGRADE (SC288)

NOTICE

This bulletin has been revised to include additional information. New/revised sections of this bulletin are indicated by a black bar in the margin area.

This bulletin provides information to inspect the fuel evaporative system and, if necessary, replace the fuel tank and/or the Purge Control Solenoid Valve (PCSV) check valve on certain 2021-2024MY K5 (DL3a) vehicles equipped with a Gamma II 1.6L T-GDI engine, produced from March 27, 2020 through October 17, 2023. This bulletin also provides information to upgrade the ECU software logic. The subject vehicles may experience fuel tank swelling due to an issue with the PCSV check valve, which results in pressurized air to flow into the fuel tank. This may cause the Check Engine Light to illuminate, and in some cases, the engine to run rough, and/or an inability to refuel. These conditions may cause the vehicle to release air pollutant which exceed Federal and California standards.

Follow the procedure outlined in this publication to inspect the fuel evaporative system and, if necessary, replace the fuel tank and/or the PCSV check valve. Before conducting the procedure, verify that the vehicle is included in the list of affected VINs.

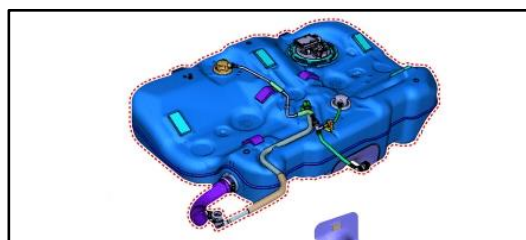

NOTICE

Repair status for a VIN is provided on KDealer+ (Service → Warranty Coverage → Warranty Coverage Inquiry → Campaign Information). Not completed Recall / Service Action reports are available on KDealer+ (Consumer Affairs → Not Completed Recall → Recall VIN → Select Report), which includes a list of affected vehicles.

FUEL TANK AND/OR PCSV CHECK VALVE INSPECTION/REPLACEMENT + ECU SW UPGRADE (SC288)

Flowchart:

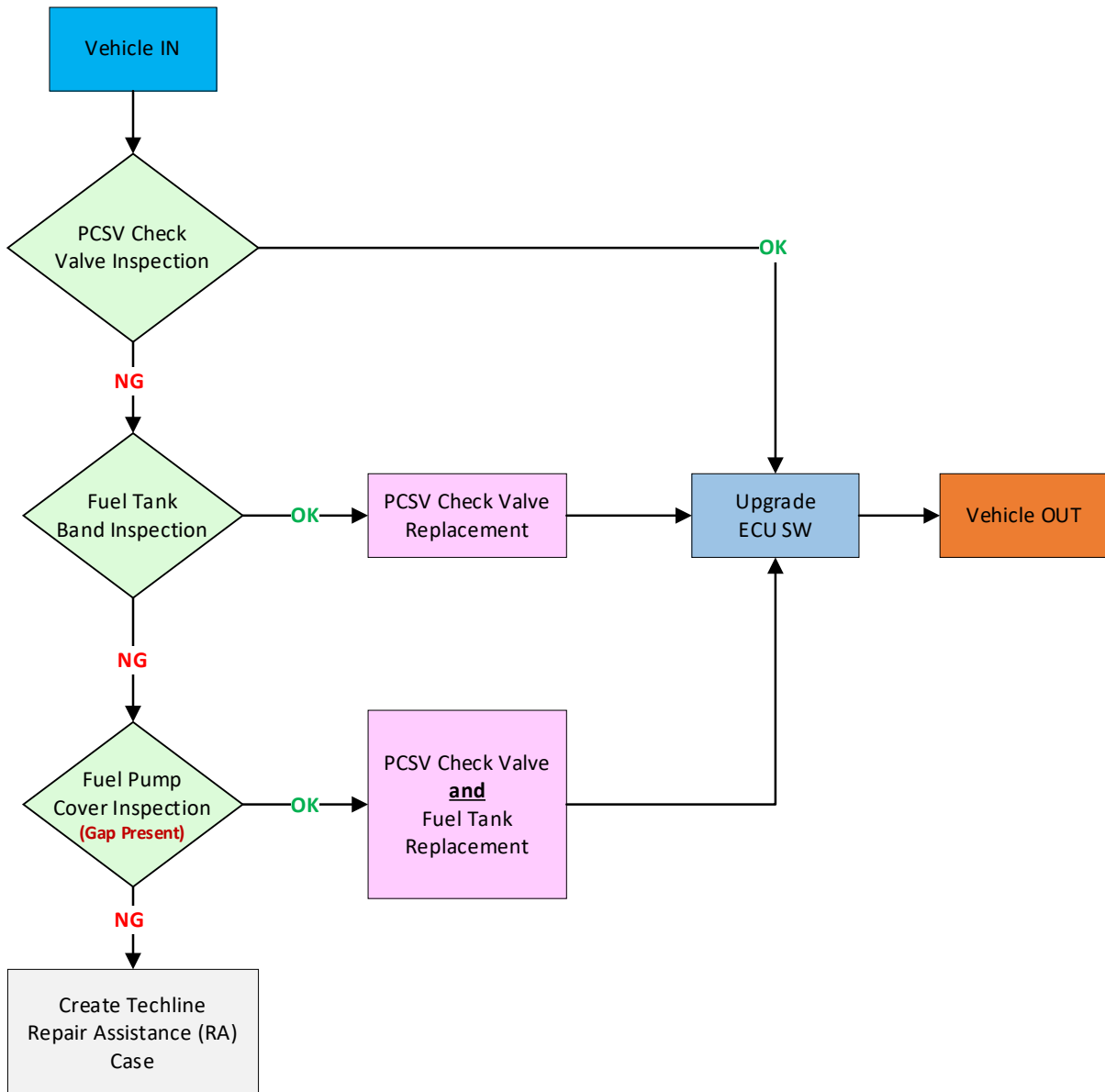

Path 1: Vehicle IN → PCSV Check Valve Inspection (OK) → Upgrade ECU SW → Vehicle OUT

Path 2: Vehicle IN → PCSV Check Valve Inspection (NG) → Fuel Tank Band Inspection (OK) → PCSV Check Valve Replacement → Upgrade ECU SW → Vehicle OUT

Path 3: Vehicle IN → PCSV Check Valve Inspection (NG) → Fuel Tank Band Inspection (NG) → Fuel Pump Cover Inspection (OK) → Fuel Tank and PCSV Check Valve Replacement → Upgrade ECU SW → Vehicle OUT

Path 4: Vehicle IN → PCSV Check Valve Inspection (NG) → Fuel Tank Band Inspection (NG) → Fuel Pump Cover Inspection (NG) → Open RA TL Case

SUBJECT:

FUEL TANK AND/OR PCSV CHECK VALVE INSPECTION/REPLACEMENT + ECU SW UPGRADE (SC288)

Inspection Procedure: (PCSV Check Valve)

1. Open the hood and locate the Purge Control Solenoid Valve (PCSV) (A).

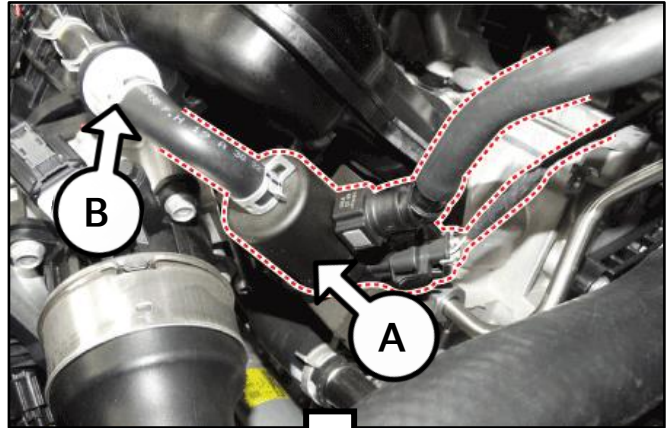

2. Disconnect the PCSV check valve (B) from the outer hose clamps ends shown.

Note: The new PCSV check valve (B) assembly comes pre-assembled with new hose clamps and vapor hoses.

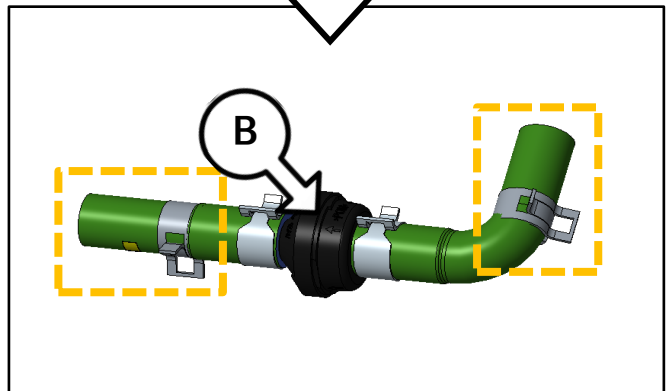

- 3a. Connect the SST air bleeding device (C) **blue air line** to the pressurization adapter (D).

SST 09580 3D100
SST KQ234 C6104FFF

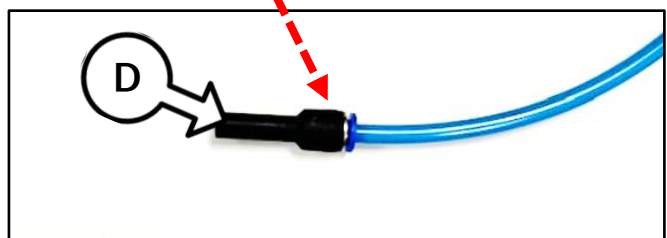
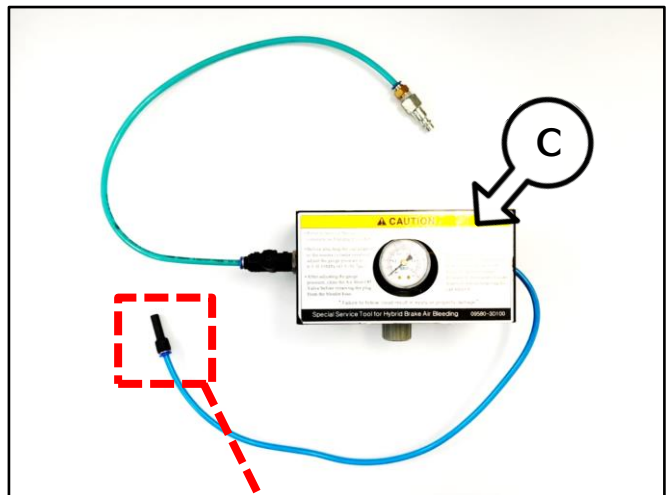

SUBJECT:

FUEL TANK AND/OR PCSV CHECK VALVE INSPECTION/REPLACEMENT + ECU SW UPGRADE (SC288)

- 3b. Connect the PCSV check valve (B) to the pressurization adapter (D).
- 3c. Connect the shop air supply hose to the air supply valve (E).
- 3d. Open shop air supply valve (E).

❗ IMPORTANT

The pressurization adapter (D) **MUST** be connected to the PCSV check valve (B) in the direction shown. If the pressurization adapter is connected incorrectly, the inspection cannot be properly conducted due to incorrect airflow to the check valve.

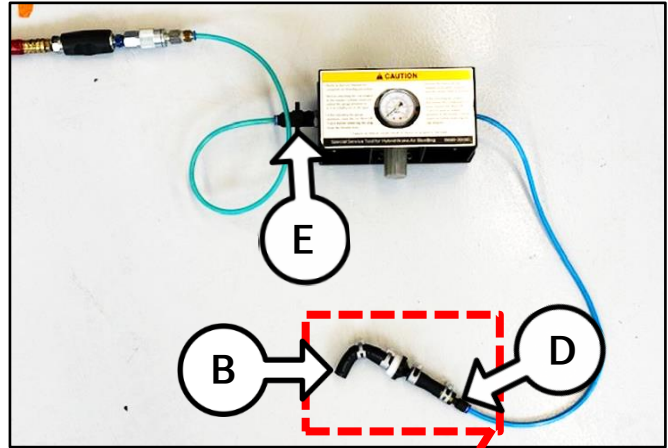

4. Slowly rotate the regulator knob (F) counterclockwise to set the air pressure between 1.4 - 1.8 bar [0.14 - 0.18 MPa].

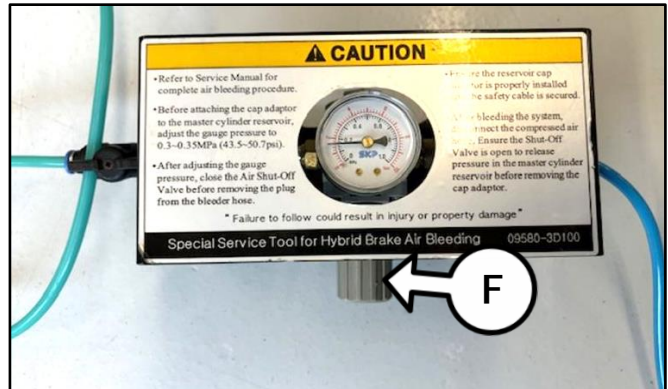

5. Submerge the open end of the PCSV check valve (B) hose in water and confirm NO air bubbles are present.

- **Bubbles ARE present (NG)**, proceed to the 'Inspection Procedure: (Fuel Tank Bands and Service Cover)' (page 5) .
- **NO bubbles present (OK)**, perform the 'ECU Upgrade Procedure' (page 8).

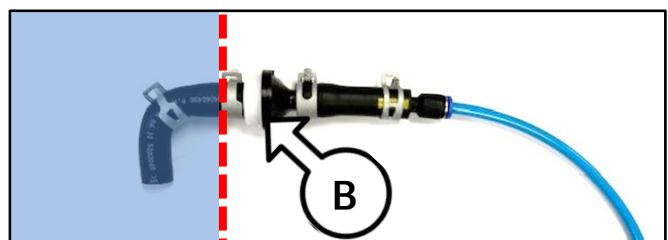
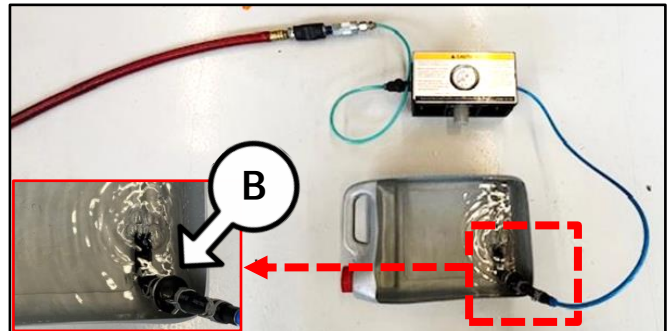

MAX Water Level

Note: DO NOT submerge the PCSV check valve (B) in the water. ONLY the hose is to be submerged in the water.



SUBJECT:

FUEL TANK AND/OR PCSV CHECK VALVE INSPECTION/REPLACEMENT + ECU SW UPGRADE (SC288)

Inspection Procedure: (Fuel Tank Bands and Service Cover)

1. Remove rear floor under covers (A).

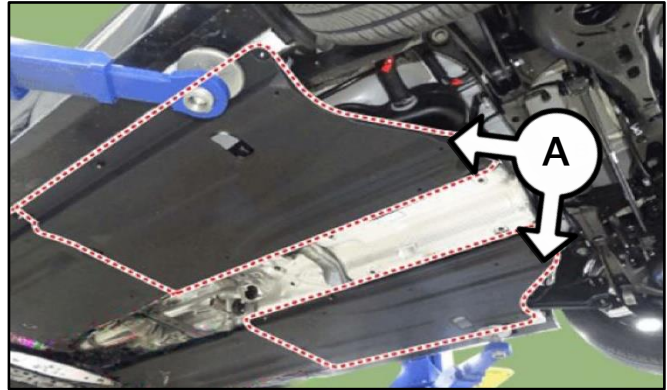

Using a ruler, measure the gap between the fuel tank (B) and BOTH fuel tank bands (C), as shown.

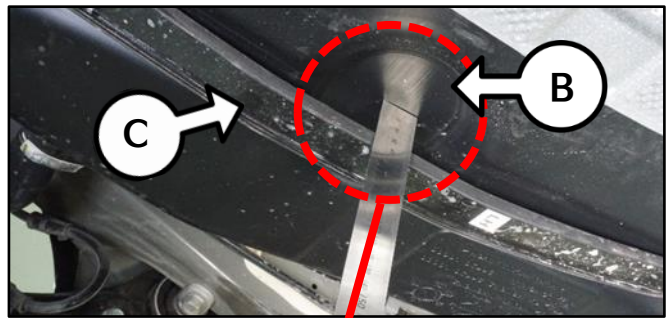

- 2a. **FWD/2WD**

- If the gap measures 24mm or LESS (OK), skip to complete the following:
 1. Replace the PCSV Check Valve
 2. ECU Upgrade Procedure (Page 8)
- If the gap measures 25mm or MORE (NG), attach one clear photo using KDS Tablet Warranty Claim Attachment Tab of the **NG** measurement, then proceed to step 3.

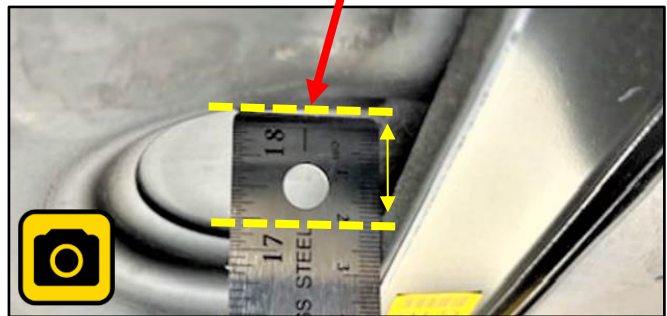

AWD/4WD

- 2b. Left Hand Fuel Tank Band

- If the gap measures 21mm or LESS (OK), proceed to measure the right hand fuel tank band.
- If the gap measures 22mm or MORE (NG), attach one clear photo using KDS Tablet Warranty Claim Attachment Tab of the **NG** measurement, then proceed to step 3.

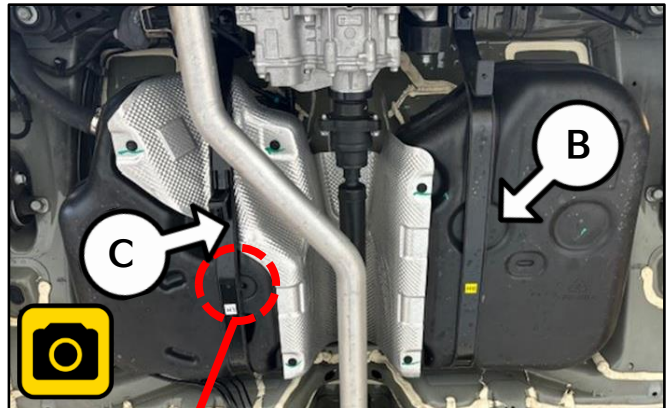

Printed TSB copy is for reference only; information may be updated at any time. Always refer to KGIS for the latest information.

TSB: SC288 (Rev 4) K5 (DL3a) April 2024



SUBJECT:

FUEL TANK AND/OR PCSV CHECK VALVE INSPECTION/REPLACEMENT + ECU SW UPGRADE (SC288)

2c. Right Hand Fuel Tank Band

- If the gap measures 13mm or LESS (OK), skip to complete the following:
 1. Replace the PCSV Check Valve
 2. ECU Upgrade Procedure (Page 8)
- If the gap measure 14mm or MORE (NG), attach one clear photo using KDS Tablet Warranty Claim Attachment Tab of the NG measurement, then proceed to step 3.

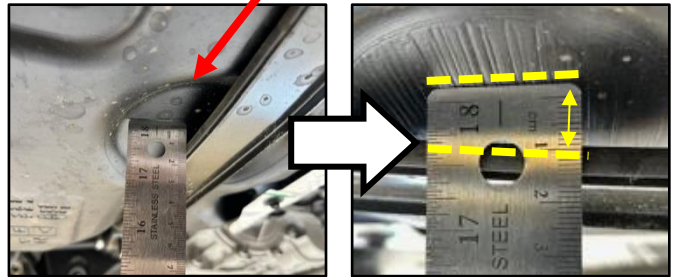
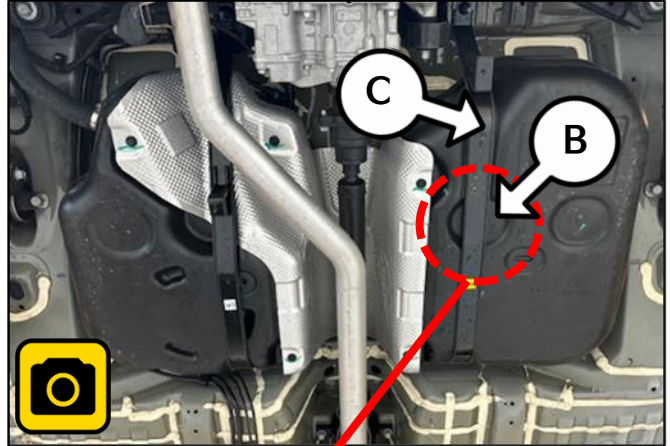

3. Remove the 2nd row bench seat (D) to access the fuel pump service cover (E).

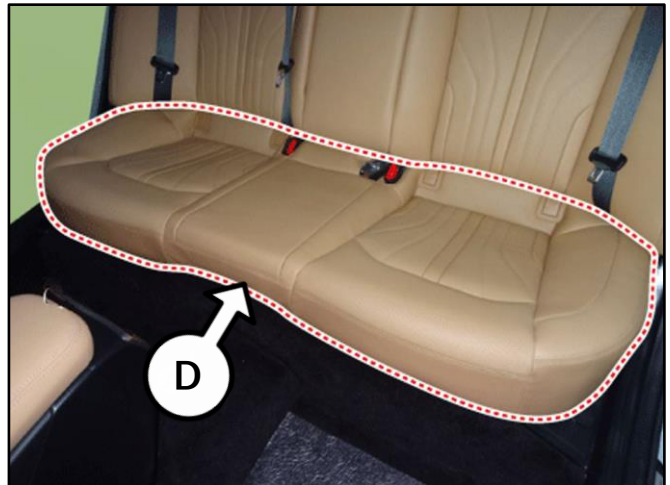

SUBJECT:

FUEL TANK AND/OR PCSV CHECK VALVE INSPECTION/REPLACEMENT + ECU SW UPGRADE (SC288)

Note: AWD model shown on the right for reference, the FWD models shown below feature a single fuel tank service cover access.



4. Inspect the seat floor to fuel pump service cover (E) (4 sides) for any gaps:

- If a gap is NOT present (OK), the cover is seated flush with the seat floor panel, then proceed to replace both the PCSV check valve and Fuel Tank (page 12). After completing the two replacements, perform the 'ECU Upgrade Procedure' (page 8).

- If a gap IS present (NG), the cover is lifted/detached from the seat floor panel, create a Techline Repair Assistance (RA) case, and attach one clear photo using KDS Tablet Warranty Claim Attachment Tab of the NG condition to the Techline case and Warranty Claim.

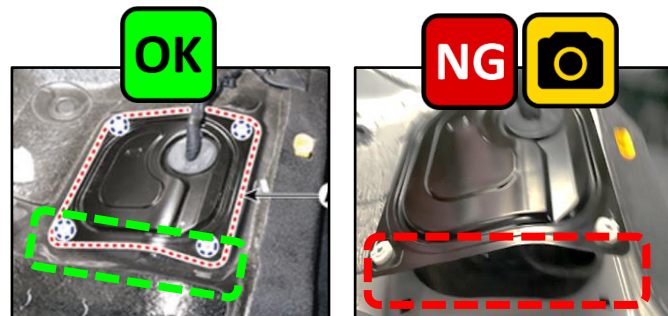

SUBJECT:

FUEL TANK AND/OR PCSV CHECK VALVE INSPECTION/REPLACEMENT + ECU SW UPGRADE (SC288)

ECU Upgrade Procedure:

To correct this condition, the ECU should be reprogrammed using the KDS download, as described in TSB [SST081](#).

Upgrade Event Name

792.DL3a Gamma 1.6TGDI ECU logic improvement for preventing fuel tank pressure increase_2nd

NOTICE

- Confirm a fully charged battery (12.3 volts or higher is necessary) is used or utilize a fully charged jump starter box connected to the battery.
- **Ensure the KDS is sufficiently charged at 60% or higher prior to reflash.**
- All ECU upgrades must be performed with the ignition set to the 'ON' position unless otherwise stated.
- **Damaged VCI II units should not be used and promptly replaced.**
- Be careful not to disconnect the VCI-II connected to the vehicle during the ECU upgrade procedure.
- **DO NOT start the engine during ECU upgrade.**
- DO NOT turn the ignition key 'OFF' or interrupt the power supply during ECU upgrade.
- **When the ECU upgrade is completed, turn the ignition 'OFF' and wait 10 seconds before starting the engine.**
- ONLY use approved ECU upgrade software designated for the correct application.

IMPORTANT

It is recommended to ALWAYS check the Electronic Parts Catalog (EPC) to locate the ECU Part Number respective to Auto/Manual Mode ROM IDs. DO NOT reference the parts label affixed to the ECU.

NOTICE

If a 'Communication Fail' error notice appears or the upgrade cannot be performed, DO NOT disconnect the KDS/VCI-II. Contact GIT America Help Desk at (888) 542-4371 or Techline.

NOTICE

Before attempting an ECU upgrade on any Kia model, make sure to first determine whether the applicable model is equipped with an immobilizer  (IMMO) security system. Failure to follow proper procedures may cause the PCM to become inoperative after the upgrade and any claims associated with this repair may be subject to chargeback.

SUBJECT:

FUEL TANK AND/OR PCSV CHECK VALVE INSPECTION/REPLACEMENT + ECU SW UPGRADE (SC288)

ROM ID INFORMATION TABLE:

Upgrade Event #792

MY	IMMO	ISG	Type	ECU P/No.	ROM ID	
					Previous	New
21MY	Yes	ISG	2WD	39121 2MKKO	TDLA1NU06F022EOK TDLA1NU06F122EOK TDLA1NU06F223EOK TDLA1NU06F424EOK TDLA1NU06F524EOK TDLA1NU06F52FEOK TDLA1NU06F6FBEOK	TDLA1NU06F7FBEOK
	No			39123 2MKKO	TDLA1NU06E022EOK TDLA1NU06E122EOK TDLA1NU06E223EOK TDLA1NU06E424EOK TDLA1NU06E524EOK TDLA1NU06E52FEOK TDLA1NU06E6FBEOK	TDLA1NU06E7FBEOK
	Yes	NON-ISG	2WD	39121 2MKTO	TDLA1NU06F022E03 TDLA1NU06F122E03 TDLA1NU06F223E03 TDLA1NU06F424E03 TDLA1NU06F524E03 TDLA1NU06F52FE03 TDLA1NU06F6FBE03	TDLA1NU06F7FBE03
	No			39123 2MKTO	TDLA1NU06E022E03 TDLA1NU06E122E03 TDLA1NU06E223E03 TDLA1NU06E424E03 TDLA1NU06E524E03 TDLA1NU06E52FE03 TDLA1NU06E6FBE03	TDLA1NU06E7FBE03
	Yes	NON-ISG	4WD	39121 2MKVO	TDLA1NU06F026K03 TDLA1NU06F126K03 TDLA1NU06F12FK03 TDLA1NU06F2FBK03	TDLA1NU06F3FBK03
	No			39123 2MKVO	TDLA1NU06E026K03 TDLA1NU06E126K03 TDLA1NU06E12FK03 TDLA1NU06E2FBK03	TDLA1NU06E3FBK03

Continued on page 10.

To verify the vehicle is affected, be sure to check the Calibration Identification of the vehicle's ECM ROM ID and reference the Information Table as necessary.



**SUBJECT: FUEL TANK AND/OR PCSV CHECK VALVE
INSPECTION/REPLACEMENT + ECU SW UPGRADE (SC288)**

ROM ID INFORMATION TABLE:

Upgrade Event #792

MY	IMMO	ISG	Type	ECU P/No.	ROM ID	
					Previous	New
22MY	Yes	ISG	2WD	39121 2MKK1	TDLA2NU06F02EE0K TDLA2NU06F12FE0K TDLA2NU06F22FE0K TDLA2NU06F3FB0K	TDLA2NU06F4FB0K
	No			39123 2MKK1	TDLA2NU06E02EE0K TDLA2NU06E12FE0K TDLA2NU06E22FE0K TDLA2NU06E3FB0K	TDLA2NU06E4FB0K
	Yes	NON-ISG	2WD	39121 2MKT1	TDLA2NU06F02EE03 TDLA2NU06F12FE03 TDLA2NU06F22FE03 TDLA2NU06F3FB03	TDLA2NU06F4FB03
	No			39123 2MKT1	TDLA2NU06E02EE03 TDLA2NU06E12FE03 TDLA2NU06E22FE03 TDLA2NU06E3FB03	TDLA2NU06E4FB03
	Yes	NON-ISG	4WD	39121 2MKV1	TDLA2NU06F02EK03 TDLA2NU06F12FK03 TDLA2NU06F22FK03 TDLA2NU06F3FBK03	TDLA2NU06F4FBK03
	No			39123 2MKV1	TDLA2NU06E02EK03 TDLA2NU06E12FK03 TDLA2NU06E22FK03 TDLA2NU06E3FBK03	TDLA2NU06E4FBK03

Continued on page 11.

To verify the vehicle is affected, be sure to check the Calibration Identification of the vehicle's ECM ROM ID and reference the Information Table as necessary.



SUBJECT:

FUEL TANK AND/OR PCSV CHECK VALVE INSPECTION/REPLACEMENT + ECU SW UPGRADE (SC288)

ROM ID INFORMATION TABLE:

Upgrade Event #792

MY	IMMO	ISG	Type	ECU P/No.	ROM ID	
					Previous	New
23MY	Yes	ISG	2WD	39121 2MKK2	TDLA3NU06F02NE0K TDLA3NU06F1NAE0K TDLA3NU06F2NBE0K	TDLA3NU06F3NBE0K
	No				TDLA3NU06E02NE0K TDLA3NU06E1NAE0K TDLA3NU06E2NBE0K	TDLA3NU06E3NBE0K
	Yes	NON-ISG	2WD	39121 2MKT2	TDLA3NU06F02NE03 TDLA3NU06F1NAE03 TDLA3NU06F2NBE03	TDLA3NU06F3NBE03
	No				TDLA3NU06E02NE03 TDLA3NU06E1NAE03 TDLA3NU06E2NBE03	TDLA3NU06E3NBE03
	Yes	NON-ISG	4WD	39121 2MKV2	TDLA3NU06F02NK03 TDLA3NU06F1NAK03 TDLA3NU06F2NBK03	TDLA3NU06F3NBK03
	No				TDLA3NU06E02NK03 TDLA3NU06E1NAK03 TDLA3NU06E2NBK03	TDLA3NU06E3NBK03
24MY	Yes	ISG	2WD	39121 2MKK3	TDLA4NU06F02YE0K TDLA4NU06F1YAE0K	TDLA4NU06F2YAE0K
	No				TDLA4NU06E02YE0K TDLA4NU06E1YAE0K	TDLA4NU06E2YAE0K
	Yes	NON-ISG	2WD	39121 2MKT3	TDLA4NU06F02YE03 TDLA4NU06F1YAE03	TDLA4NU06F2YAE03
	No				TDLA4NU06E02YE03 TDLA4NU06E1YAE03	TDLA4NU06E2YAE03
	Yes	NON-ISG	4WD	39121 2MKV3	TDLA4NU06F02YK03 TDLA4NU06F1YAK03	TDLA4NU06F2YAK03
	No				TDLA4NU06E02YK03 TDLA4NU06E1YAK03	TDLA4NU06E2YAK03

To verify the vehicle is affected, be sure to check the Calibration Identification of the vehicle's ECM ROM ID and reference the Information Table as necessary.



SUBJECT: **FUEL TANK AND/OR PCSV CHECK VALVE
INSPECTION/REPLACEMENT + ECU SW UPGRADE (SC288)**

Refer to [TSB SST081](#) for instructions to upgrade the 'ENGINE' system:

UPGRADE EVENT:

792.DL3a Gamma 1.6TGDI ECU logic improvement for preventing fuel tank pressure increase_2nd

NOTICE

Prior to performing the ECU upgrade, be sure to check that the KDS is fully charged.



Manual Mode:

NOTICE

The manual upgrade should ONLY be performed if the automatic upgrade fails.
If the automatic upgrade fails, turn the ignition 'OFF' for about 10 seconds then place it back in the 'ON' position to reset the control unit BEFORE performing manual upgrade.
 See table below for 'Manual Mode' passwords and refer to TSB [SST081](#) for instructions.

Manual Mode ECU Upgrade Passwords

Menu	Password
DL3a -IMMO +ISG (21MY): 39123-2MKK0	1601
DL3a +IMMO/SMK +ISG (21MY): 39121-2MKK0	1602
DL3a -IMMO (21MY): 39123-2MKTO	1603
DL3a +IMMO/SMK (21MY): 39121-2MKTO	1604
DL3a -IMMO 4WD (21MY): 39123-2MKVO	1605
DL3a +IMMO/SMK 4WD (21MY): 39121-2MKVO	1606
DL3a -IMMO +ISG (22MY): 39123-2MKK1	1607
DL3a +IMMO/SMK +ISG (22MY): 39121-2MKK1	1608
DL3a -IMMO (22MY): 39123-2MKT1	1609
DL3a +IMMO/SMK (22MY): 39121-2MKT1	1610
DL3a -IMMO 4WD (22MY): 39123-2MKV1	1611
DL3a +IMMO/SMK 4WD (22MY): 39121-2MKV1	1612
DL3a -IMMO +ISG (23MY): 39123-2MKK2	1613
DL3a +IMMO/SMK +ISG (23MY) : 39121-2MKK2	1614
DL3a -IMMO 4WD (23MY) : 39123-2MKT2	1615
DL3a +IMMO/SMK (23MY) : 39121-2MKT2	1616
DL3a -IMMO (23MY) : 39123-2MKV2	1617
DL3a +IMMO/SMK 4WD (23MY) : 39121-2MKV2	1618
DL3a -IMMO +ISG (24MY) : 39123-2MKK3	1619
DL3a +IMMO/SMK +ISG (24MY) : 39121-2MKK3	1620
DL3a -IMMO (24MY) : 39123-2MKT3	1621
DL3a +IMMO/SMK (24MY) : 39121-2MKT3	1622
DL3a -IMMO 4WD (24MY) : 39123-2MKV3	1623
DL3a +IMMO/SMK 4WD (24MY) : 39121-2MKV3	1624



SUBJECT:

FUEL TANK AND/OR PCSV CHECK VALVE INSPECTION/REPLACEMENT + ECU SW UPGRADE (SC288)

Replacement Procedure: **Fuel Tank**

1. Replace the fuel tank (A) by referring to "Engine Control / Fuel System → Fuel Delivery System → Fuel Tank → Repair procedures" in the applicable Shop Manual on KGIS.

Note: Be sure to replace all fuel tank related parts such as:

1. Fuel Tank (15 Gal. or 16 Gal.)
2. Fuel Tank Pads
3. Fuel Tank Heat Protector
4. Fuel Tank Bands
5. Ring Lock (AWD)

In addition, replace the non-resuable parts:

1. Rear Muffler Gasket
2. Fuel Pump Service Cover (if damaged)
3. Fuel Pump Packing (if damaged)
4. Propeller Shaft Bolts (AWD only)

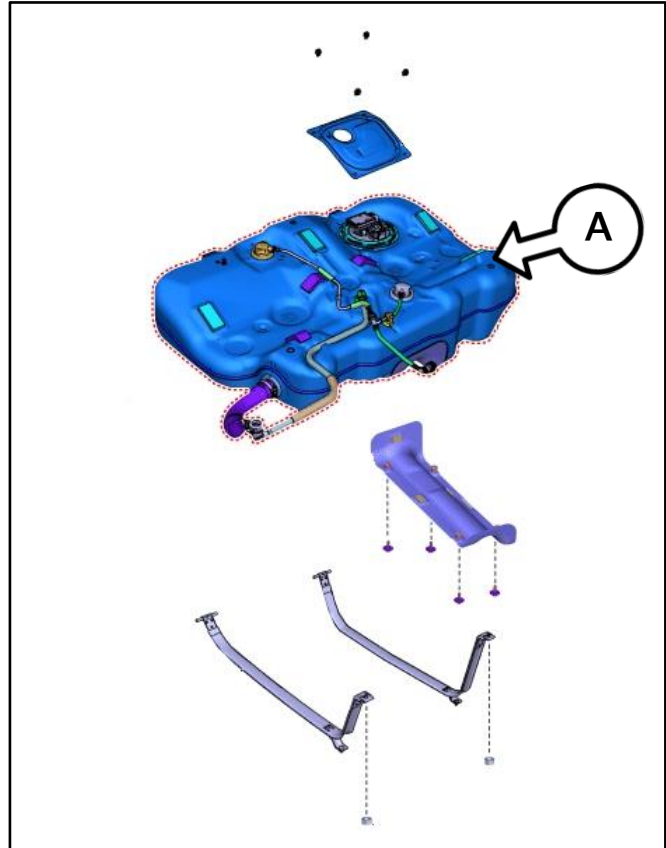

2. Reinstall all removed parts in reverse order of removal.
3. Replace the PCSV Check Valve.
4. Perform the ECU SW Upgrade (Pages 8-11).
5. Confirm normal vehicle operation.

SUBJECT: **FUEL TANK AND/OR PCSV CHECK VALVE
INSPECTION/REPLACEMENT + ECU SW UPGRADE (SC288)**

ATTENTION: THE PROOF OF CORRECTION CARD AND CAMPAIGN COMPLETION LABEL ARE RESTRICTED ONLY TO DEALERS IN THE FOLLOWING STATES:

California, Connecticut, Delaware, Massachusetts, Maine, Maryland, New Jersey, New York, Oregon, Pennsylvania, Rhode Island, Vermont, and Washington. See Parts Information below to order the Proof of Correction Card and Campaign Completion Label from the PDC.

VEHICLE EMISSION RECALL - PROOF OF CORRECTION CARD

A Vehicle Emission Recall - Proof of Correction card must be filled out for all vehicles registered in California, Connecticut, Delaware, Massachusetts, Maine, Maryland, New Jersey, New York, Oregon, Pennsylvania, Rhode Island, Vermont, and Washington. Residents of these states, who own an affected vehicle, will be required to possess a Vehicle Emission Recall - Proof of Correction card as evidence of voluntary service campaign completion, when they apply for vehicle registration renewal.

WHAT TO DO WITH THE CARD:

The Vehicle Emission Recall - Proof of Correction card must be completed by the Dealership's Service Manager using a permanent ink pen. A fine point pen is recommended. When filling in the information, copy the information directly from the vehicle, not the repair order. **ALL INFORMATION MUST BE PRINTED AND NEAT.**

NOTE: DO NOT COMPLETE THE CARD UNLESS THE SERVICE CAMPAIGN WORK IS COMPLETED.

The copy of the card shown below indicates the areas to be filled in. Each area must be filled in. The completed card should be given to the owner of the vehicle upon completion of the Campaign and placement of the Campaign Completion Label outlined below.

FILLING OUT AND APPLYING THE CAMPAIGN COMPLETION LABEL (CA and S.177 STATES ONLY):

The dealer must fill in the Dealer Code and Date information fields on the Campaign Completion Label. Once complete, affix the campaign completion label under the hood of the vehicle, as shown below.

CA and S.177 States Only: Apply SC288 Campaign Completion Label onto the body in the area next to the shock tower, as shown. **NOTE: Be sure to clean the mounting surface to ensure proper label adhesion.**





SUBJECT:

FUEL TANK AND/OR PCSV CHECK VALVE INSPECTION/REPLACEMENT + ECU SW UPGRADE (SC288)

AFFECTED VEHICLE RANGE:



Model	Production Date Range
K5 (DL3a)	March 27, 2020 to October 17, 2023

REQUIRED TOOL:

Tool Name	Part Number	Figure	Comments
KDS	N/A		Kia Diagnostic System
Air Bleeding Tool	09580 3D100		Located Toolbox 2 Drawer #16
Pressurization Adapter	KQ234 C6104FFF		Part of KQ234-C6200FFF Cleaning Kit Per ENG222 Located 'SHOP'

**SUBJECT: FUEL TANK AND/OR PCSV CHECK VALVE
INSPECTION/REPLACEMENT + ECU SW UPGRADE (SC288)**

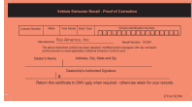
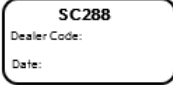
REQUIRED PART:

Part Name	Part Number	Figure	Qty.
Campaign Completion Label	UT160 SC288		1
Vehicle Emissions Recall Proof of Correction Card	UT161 SC288		1
PCSV Check Valve Assy	28918 2M430QQK		1

Note: The replacement part number 28918 2M430QQK will require a VIN entry for parts ordering. **DO NOT** order this part for stocking purposes, related to this Campaign. Supply is very limited. Until supply stabilizes, please confirm part availability before scheduling customers. Please be sure to expedite warranty claim filing.

Part Name	Part Number (FWD)	Part number (AWD)	Qty.
Fuel Tank	31150 L0600 (56L/15 Gal.) 31150 L0000 (60L/16 Gal.)	31150 L3600 (60L/16 Gal.)	1
Fuel Tank Heat Protector	31220 L1000	31220 L3600	1
Fuel Tank Band (LH)	31210 L1000	31210 L3600	1
Fuel Tank Band (RH)	31211 L1000	31211 L3600	1
Rear Muffler Gasket	28751 2T000		1
Fuel Pump Service Cover	31107 L1000		1
Fuel Pump Packing	31115 0W000		1
Fuel Tank Pads	31101 L1100	31101 L3600	2
	31101 C1000		5
	31101 L1000	31101 L1000	2
	31101 3X000		1
		31101 C8000	8
Ring Lock		31152 0W000	1
Propeller Shaft Bolts		11435 10256K	1



SUBJECT:

FUEL TANK AND/OR PCSV CHECK VALVE INSPECTION/REPLACEMENT + ECU SW UPGRADE (SC288)

WARRANTY INFORMATION:

N Code: N99 C Code: C99

Claim Type	Causal P/N	Qty.	Repair Description	Labor Op Code	Op Time	Replacement P/N	Qty.
R	59133 2H000	0	(SC288) PCSV Inspection (OK) + ECU SW Upgrade	240A0312	0.5 M/H	N/A	1
			(SC288) PCSV Inspection (NG) + PCSV Replacement + Fuel Tank Band Inspection (OK) + ECU SW Upgrade (FWD)	240A03RB	0.9 M/H	28918 2M430QQK	1
			(SC288) PCSV Inspection (NG) + PCSV Replacement + Fuel Tank Band Inspection (OK) + ECU SW Upgrade (AWD)	240A03RC	1.0 M/H	28918 2M430QQK	1

Continued on page 18.

NOTICE

VIN inquiry data for this repair is provided for tracking purposes only. Kia retailers should reference SC288 when accessing the KDealer+ system.



SUBJECT: **FUEL TANK AND/OR PCSV CHECK VALVE
INSPECTION/REPLACEMENT + ECU SW UPGRADE (SC288)**

Claim Type	Causal P/N	Qty.	Repair Description	Labor Op Code	Op Time	Replacement P/N	Qty.
R	59133 2H000	0	(SC288) PCSV Inspection (NG) + PSCV Replacement + Fuel Tank Band Inspection (NG) + Service Cover Inspection (OK)+ Tank Replacement + ECU SW Upgrade (FWD)	240A03RD*	2.1 M/H	28918 2M430QQK	1
						31150 L0600 or 31150 L0000	1
						31220 L1000	1
						31210 L1000	1
						31211 L1000	1
						28751 2T000	1
						31107 L1000	1
						31115 OW000	1
						31101 L1100	2
						31101 C1000	5
						31101 L1000	2
						31101 3X000	1
		0	(SC288) PCSV Inspection (NG) + PSCV Replacement + Fuel Tank Band Inspection (NG) + Service Cover Inspection (OK)+ Tank Replacement + ECU SW Upgrade (AWD)	240A03RE*	2.3 M/H	28918 2M430QQK	1
						31150 L3600	1
						31220 L3600	1
						31210 L3600	1
						31211 L3600	1
						28751 2T000	1
						31107 L1000	1
						31115 OW000	1
31101 L3600	2						
31101 L1000	2						
31101 C8000	8						
31152 OW000	1						
11435 10256K	1						
0	(SC288) PCSV Inspection (NG) + Fuel Tank Band & Service Cover Inspection (NG) (Techline RA Open Required) (FWD)	240A03RF*	0.6 M/H	N/A	0		
						(SC288) PCSV Inspection (NG) + Fuel Tank Band & Service Cover Inspection (NG) (Techline RA Open Required) (AWD)	240A03RA*

Note: Refer to [Warranty Bulletin 2024-27](#) for claim submission procedures. Manually enter sublet code 'X2' for reimbursement of one roundtrip rideshare expense or up to three (3) days of rental expense, with supporting documentation. *A photo of the 'NG' condition, as described in this TSB MUST be attached to the claim using Warranty Claim Attachment Type 'XX - Other' for LOP 240A03P3, 240A03P4, 240A03RF and 240A03RA.

NOTICE

VIN inquiry data for this repair is provided for tracking purposes only. Kia retailers should reference **SC288** when accessing the KDealer+ system.

