



STAR ONLINE PUBLICATION



Case Number: S2219000007 Rev. A

Release Date: October 2024

Symptom/Vehicle Issue: Service Electric Power Steering (EPS) Message Displayed on Cluster Upon Start Up

Customer Complaint/Technician Observation: Owner complains of a cluster message to service the EPS system when starting the vehicle. Technician observed the Diagnostic Trouble Codes (DTCs) C2217-00 EPS Module Internal, and C1592-00 EPS Motor Circuit set at the same time.

Discussion: If the above DTCs are setting at start up the root cause could be related to a voltage issue or voltage drop condition. Inspect, disassemble, clean, and tighten the battery B+, ground cables, and connections. Use the battery testing function of the MOPAR Optimus battery charger to test the battery condition. Inspect EPS redundant B+ feeds and grounds (G905a G906A) for any voltage drop prior to any parts replacement.

This document does not authorize warranty repairs. This communication documents a record of past experiences. STAR Online does not provide any conclusions about what is wrong with the vehicle. Rather, it captures all previous cases known that appear to be similar or related to the vehicle symptom / condition. You are the expert, and you are responsible for deciding on the appropriate course of action.

Contact STAR Center, or your Technical Assistance Center Via TechCONNECT or eCONTACT ticket if no solution is found



STAR ONLINE PUBLICATION

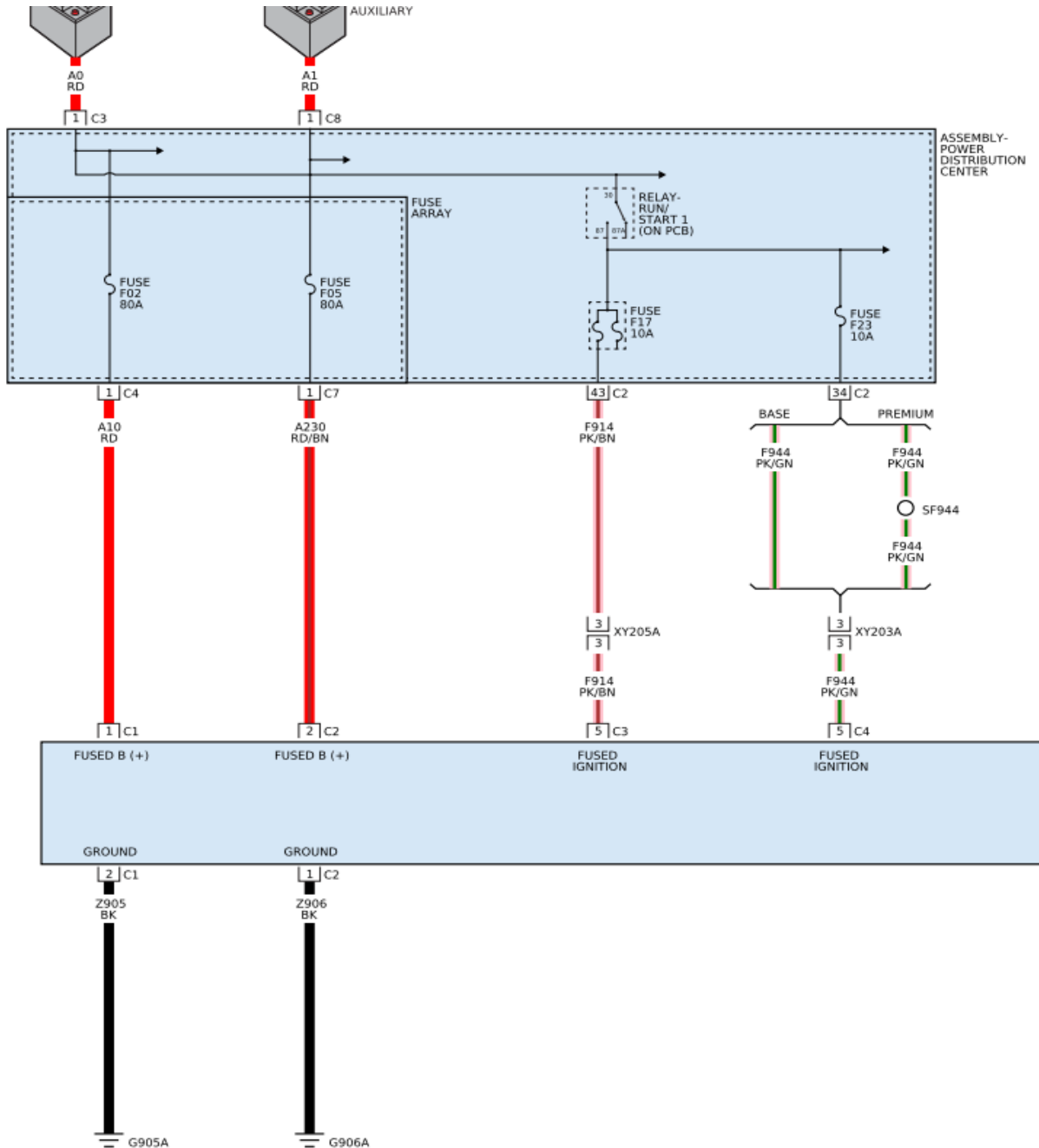

This document does not authorize warranty repairs. This communication documents a record of past experiences. STAR Online does not provide any conclusions about what is wrong with the vehicle. Rather, it captures all previous cases known that appear to be similar or related to the vehicle symptom / condition. You are the expert, and you are responsible for deciding on the appropriate course of action.

Contact STAR Center, or your Technical Assistance Center Via TechCONNECT or eCONTACT ticket if no solution is found



STAR ONLINE PUBLICATION

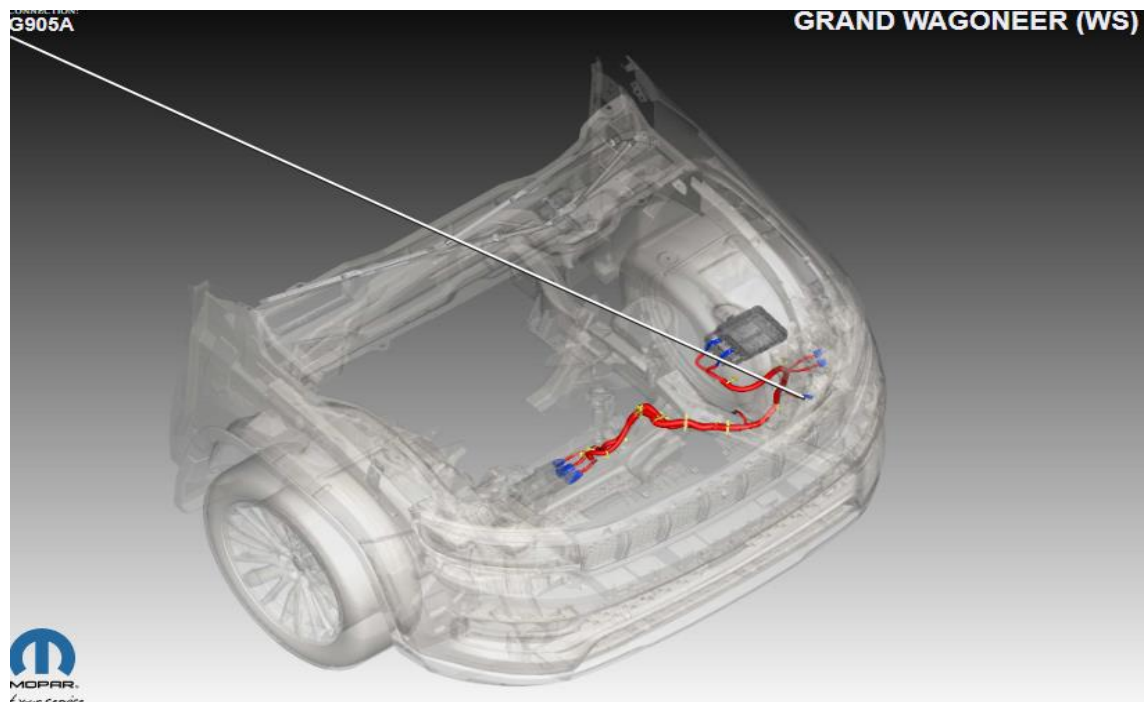
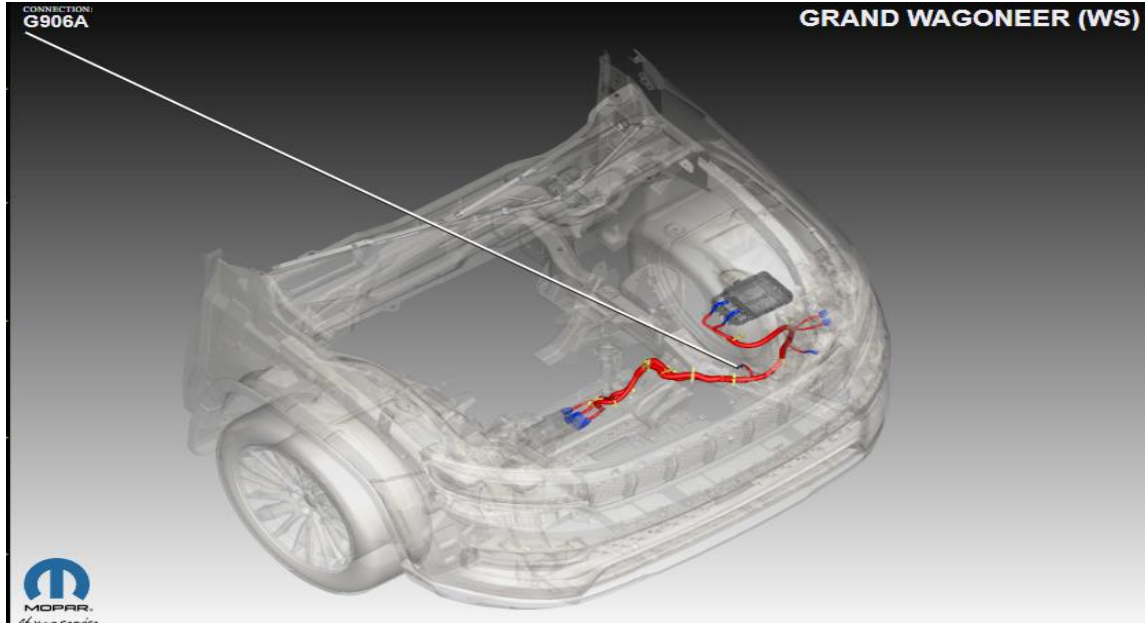

This document does not authorize warranty repairs. This communication documents a record of past experiences. STAR Online does not provide any conclusions about what is wrong with the vehicle. Rather, it captures all previous cases known that appear to be similar or related to the vehicle symptom / condition. You are the expert, and you are responsible for deciding on the appropriate course of action.

Contact STAR Center, or your Technical Assistance Center Via TechCONNECT or eCONTACT ticket if no solution is found