

**Complaint - Exterior Mirror does not Fold In/Out: Troubleshooting (112/24)**

Model Line: **Macan (95B)**

Model Year: **As of 2014 up to 2018**

Concerns: **Mirror-adjusting motor (folding function) right/left**

Cause: **Customers complain that one or both exterior mirrors of the vehicle do not fold in/out.**

Action: Should there be a customer complaint, check the voltage / power supply of the front door control unit and the mirror-adjusting motor (folding function).

**Required tools**

- Tools:
- **P90999 - PIWIS Tester 4**
  - Battery charger with a current rating of **at least 90 A**, e.g. **VAS 5908 - 90-A battery charger**. For further information about the battery chargers to be used, see the corresponding Workshop Manual. *⇒ Workshop Manual '2X00IN Battery trickle charge'*
  - Multimeter, e.g. **V.A.G 1526E - hand-held multimeter**
  - Current measuring pliers, e.g. **100 A clamp-on ammeter 9900/ET 310 (yellow)**
  - **Measurement equipment for PIWIS Tester 3 & 4**

**Check voltage / power supply of the front door control unit and the mirror-adjusting motor (folding function)**

- Work Procedure: 1 Remove front door trim panel on the respective side of the faulty mirror.  
*⇒ Workshop Manual '705919 Removing and installing front door trim panel'*
- 2 Connect and switch on the battery charger.
- 3 Prepare PIWIS Tester for activation of mirror-adjusting motor (folding function).
- 3.1 **P90999 - PIWIS Tester 4** must now be connected.
- 3.2 If necessary, select car type.
- 4 Measure output voltage on the front door control unit *⇒ Pin C9 and Pin C10 front door control unit -1-* of the faulty mirror.

- 4.1 Position measuring points of the **V.A.G 1526E - hand-held multimeter** on electric plug connection **C** ⇒ **Pin C9 and Pin C10 front door control unit -2-** when plugged in on **pin C9** ⇒ **Pin C9 and Pin C10 front door control unit -3-** and **pin C10** of ⇒ **Pin C9 and Pin C10 front door control unit -4-** the front door control unit.
- 4.2 In the PIWIS Tester, select the '**Front door**' control unit of the respective door and in the '**Actuator checks**' menu, press the '**Fold in exterior mirror**' or '**Fold out exterior mirror**' function and follow the tester's instructions.
- 4.3 Track the voltage curve in the **V.A.G 1526E - hand-held multimeter** during actuator diagnosis.

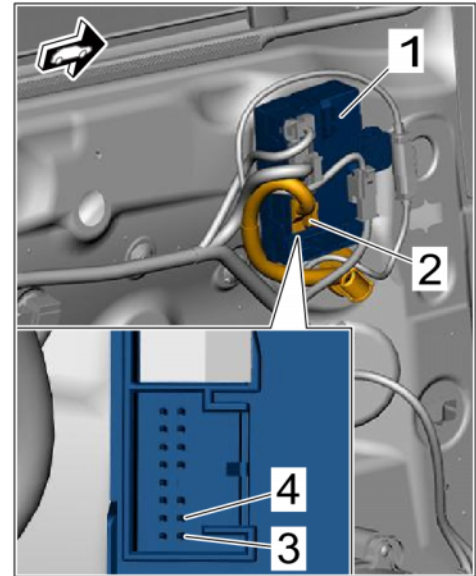

*Pin C9 and Pin C10 front door control unit*

- 5 If both exterior mirrors are affected, carry out the measurement under ⇒ 4 on the other door on the door control unit in the same way.
- 6 Evaluate voltage measurement.

Assessment		Action
(✓)	The output voltage at <b>pins C9 and C10</b> is around <b>12 V</b> .	The front door control unit output voltage corresponds to the setpoint value and is <b>OK</b>  Continue with Step ⇒ 7.
(✗)	There is no output voltage at <b>pins C9 and C10</b> .	The front door control voltage control unit does <b>not</b> correspond to the target value and is <b>not OK</b> .  Disconnect and reconnect battery and repeat measurement. If there is still no output voltage after disconnecting and reconnecting the battery, perform troubleshooting on the front door control unit or on the vehicle-side wiring.

- 7 Carry out current measurement on front door control unit.
- 7.1 Connect **P90999 - PIWIS Tester 4** to **9900/ET 420 - measurement and test equipment for PIWIS Tester 3 & 4**.

7.2 Connect **100 A clamp-on ammeter 9900/ET 310 (yellow)** to channel 1 on **measurement and test equipment for PIWIS Tester 3 & 4**. ⇒ *Clamp-on ammeter to measurement and test equipment*

7.3 On **P90999 - PIWIS Tester 4**, select the **Measurement and test equipment** function.

7.4 Select **Oscilloscope**.

Follow the instructions and information on the Tester.

7.5 Expose electric lines until **100 A clamp-on ammeter 9900/ET 310 (yellow)** can be connected.

7.6 Connect **100 A clamp-on ammeter 9900/ET 310 (yellow)** to the electric line when plugged in to **pin C9 or C10** of the front door control unit.

7.7 In the PIWIS Tester, select the **'Front door'** control unit of the respective door and in the **'Actuator checks'** menu, press the **'Fold in exterior mirror'** or **'Fold out exterior mirror'** function and follow the tester's instructions.

7.8 Track the current consumption in **P90999 - PIWIS Tester 4** during actuator diagnosis.



*Connecting clamp-on ammeter to measurement and test equipment*

8 Evaluate current measurement.

Assessment		Action
(✓)	Mirror-adjusting motor (folding function) consumes current on <b>pin C9 or C10</b> .	Activation of mirror-adjusting motor (folding function) <b>OK</b> . Continue with Step ⇒ 9.
(✗)	Mirror-adjusting motor (folding function) on <b>pin C9 or C10</b> does <b>not</b> consume any current.	Activation of mirror-adjusting motor (folding function) <b>not OK</b> . Disconnect and reconnect battery and repeat measurement. If there is still no current flowing after the vehicle battery is discharged, perform troubleshooting on the front door control unit or on the vehicle-side cabling.

9 Release mirror-adjusting motor (folding function) until electric plug connection for mirror-adjusting motor becomes ⇒ *Electric plug connection for mirror-adjusting motor (folding function) -1-* accessible.

For work procedure, see: ⇒ *Workshop Manual '66821903 Remove and install mirror-adjusting motor (folding function)'*

10 Measure output voltage on electric plug connection for mirror-adjusting motor (folding function) ⇒ *Electric plug connection for mirror-adjusting motor (folding function) -1-*.

10.1 Loosen electric plug connection for mirror-adjusting motor (folding function) ⇒ *Electric plug connection for mirror-adjusting motor (folding function) -1-* from the bracket, then release and disconnect it.

10.2 Check electric plug connection for mirror-adjusting motor (folding function) ⇒ *Electric plug connection for mirror-adjusting motor (folding function) -1-* for corrosion, clean electric plug connection if necessary.

10.3 Connect and lock electric plug connection for mirror-adjusting motor (folding function).

10.4 Connect measuring points of the **V.A.G 1526E - hand-held multimeter** to the electric plug connection when plugged in to **pin A** ⇒ *Electric plug connection for mirror-adjusting motor (folding function) -2-* and **pin B** ⇒ *Electric plug connection for mirror-adjusting motor (folding function) -3-* of the mirror-adjusting motor (folding function).

10.5 In the PIWIS Tester, select the '**Front door**' control unit of the respective door and in the '**Actuator checks**' menu, press the '**Fold in exterior mirror**' or '**Fold out exterior mirror**' function and follow the tester's instructions.

10.6 Track the voltage curve in the **V.A.G 1526E - hand-held multimeter** during actuator diagnosis.

11 If both exterior mirrors are affected, carry out the measurement below ⇒ 10 on the electric plug connection for mirror, adjusting motor in the same way as the other door.

12 Evaluate voltage measurement.

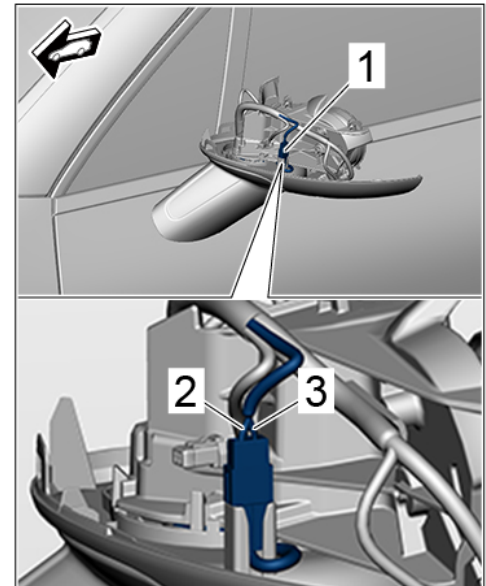

*Electric plug connection for mirror-adjusting motor (folding function)*

Assessment		Action
(✓)	The output voltage at <b>pins A and B</b> is approximately <b>12 V</b> .	The output voltage at the electric plug connections corresponds to the setpoint value and is <b>OK</b> .  Continue with Step ⇒ 13.
(✗)	There is no output voltage at <b>pins A and B</b> .	The output voltage on the electrical plug connection does <b>not</b> correspond to the target value and is <b>not OK</b> .

	<p>Disconnect and reconnect battery and repeat measurement. If there is still no output voltage after disconnecting and reconnecting the battery, perform troubleshooting on the front door control unit or on the vehicle-side wiring.</p>
--	---

- 13 Carry out current measurement on the mirror-adjusting motor electrical plug connection.
  - 13.1 Connect **P90999 - PIWIS Tester 4** to **9900/ET 420 - measurement and test equipment for PIWIS Tester 3 & 4**.
  - 13.2 Connect **100 A clamp-on ammeter 9900/ET 310 (yellow)** to channel 1 on **measurement and test equipment for PIWIS Tester 3 & 4**. ⇒ *Clamp-on ammeter to measurement and test equipment*
  - 13.3 On **P90999 - PIWIS Tester 4**, select the **Measurement and test equipment** function.
  - 13.4 Select **Oscilloscope**.  
Follow the instructions and information on the Tester.
  - 13.5 Expose electric lines until **100 A clamp-on ammeter 9900/ET 310 (yellow)** can be connected.
  - 13.6 Connect **100 A clamp-on ammeter 9900/ET 310 (yellow)** to the plugged in electrical line of **pin A or pin B** of the mirror-adjusting motor (folding function).
  - 13.7 In the PIWIS Tester, select the '**Front door**' control unit of the respective door and in the '**Actuator checks**' menu, press the '**Fold in exterior mirror**' or '**Fold out exterior mirror**' function and follow the tester's instructions.
  - 13.8 Track the current consumption in **P90999 - PIWIS Tester 4** during actuator diagnosis.
- 14 Evaluate current measurement.



*Clamp-on ammeter to measurement and test equipment*

Assessment		Action
(✓)	Mirror-adjusting motor (folding function) consumes current at <b>pin A or pin B</b> .	Activation of mirror-adjusting motor (folding function) <b>OK</b> . Continue with Step ⇒ 15.
(✗)	Mirror-adjusting motor (folding function) on <b>pin A or pin B</b> does <b>not</b> consume any current.	Activation of mirror-adjusting motor (folding function) <b>not OK</b> . Disconnect and reconnect battery and repeat measurement. If there is still no current flowing after the vehicle battery is discharged, perform troubleshooting on the front door control unit or on the vehicle-side cabling.

## 15 Check mirror-adjusting motor (folding function).

- 15.1 Release and disconnect electric plug connection for mirror-adjusting motor (folding function) ⇒ *Electric plug connection on control unit for door-1* on the front door control unit ⇒ *Electric plug connection on control unit for door-2*.
- 15.2 Power **pins C9 and C10** of the electric plug connection for mirror-adjusting motor (folding function) with 12V.

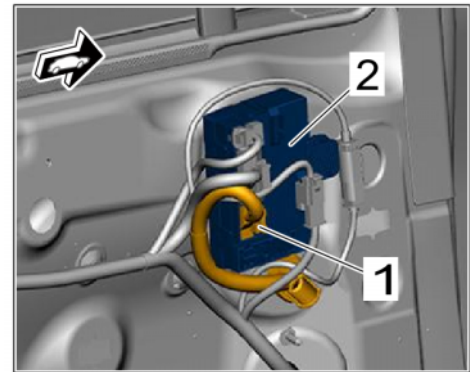

*Electric plug connection on control unit for door*

Assessment		Action
(✓)	Mirror-adjusting motor (folding function) moves.	Mirror-adjusting motor (folding function) <b>OK</b> .
(✗)	Mirror-adjusting motor (folding function) does <b>not</b> move.	Remove mirror-adjusting motor (folding function). Check mirror-adjusting motor (folding function) once again after removal. – If mirror-adjusting motor (folding function) is <b>OK</b> . ⇒ Clean adjusting mechanism. – If mirror-adjusting motor (folding function) is <b>not OK</b> . ⇒ <b>Replace</b> mirror-adjusting motor (folding function). ⇒ <i>Workshop Manual '66821903 Remove and install mirror-adjusting motor (folding function)'</i>



**Information**

If all tests were OK or if the fault no longer occurs after cleaning the mirror-adjusting mechanism, the cause of the fault may also have been tension in the mirror-adjusting mechanism that has been resolved during dismantling.

**Labor position and PCSS encryption**



**Information**

The labor time to be invoiced must be documented and invoiced in the same way as the actual troubleshooting test steps carried out.

Labor position:

APOS	Labour operation	I No.
70591901	Removing and installing front door trim panel	
70591902	Removing and installing front door trim panel	
66821903	Removing and installing mirror-adjusting motor	
66821904	Removing and installing mirror-adjusting motor	
57739590	Front door control unit troubleshooting	

PCSS encryption:

Location (FES5)	66820	Mirror-adjusting motor
Damage type (SA4)	1611	does not work

**Important Notice:** Technical Bulletins issued by Porsche Cars North America, Inc. are intended only for use by professional automotive technicians who have attended Porsche service training courses. They are written to inform those technicians of conditions that may occur on some Porsche vehicles, or to provide information that could assist in the proper servicing of a vehicle. Porsche special tools may be necessary in order to perform certain operations identified in these bulletins. Use of tools and procedures other than those Porsche recommends in these bulletins may be detrimental to the safe operation of your vehicle, and may endanger the people working on it. Properly trained Porsche technicians have the equipment, tools, safety instructions, and know-how to do the job properly and safely. Part numbers listed in these bulletins are for reference only. The work procedures updated electronically in the Porsche PIWIS diagnostic and testing device take precedence and, in the event of a discrepancy, the work procedures in the PIWIS Tester are the ones that must be followed.

© 2024 Porsche Cars North America, Inc.