

APA3 – Replacing Axle Struts on Front and Rear Axles (Stop Use / Recall Campaign)

Model Line: **Carrera GT (980)**

Model Year: **As of 2004 up to 2006**

- Concerns:
- **Wishbones on the front and rear axles**
 - **Push rod (push rods) on the rear axle**
 - **Tie rod joints on rear axle**

Cause: **During internal quality analyses, it has been determined that the trailing links and wishbones on the front and rear axles of the affected vehicles are susceptible to corrosion in the long term and therefore do not meet the required durability specifications.**
 If the fastening bolts on the trailing links and wishbones break due to corrosion, vehicle handling may be reduced, increasing the risk of accident.

Action: **Front axle:**

- Replace top left and right wishbones
- Replace lower left and right wishbones

Rear axle:

- Replace top left and right control arms
- Replacing tie rod joints on the left and right on the wheel and body sides
- Replace left and right push rod
- Replace lower left and right control arms

Further actions:

- Vehicle check (optional)

**Information**

Due to the Stop Use and the associated holding time of the vehicles, Porsche has the option when carrying out the campaign of performing, at the customer's request, either a comprehensive vehicle check or pending maintenance service at pro rata cost sharing. Porsche offers a maximum cost sharing of \$ 3,240 per vehicle.

With regard to the scope of the vehicle check, the following criteria and test points can be used as a guide:

- Test points according to the specifications for annual or minor service.
- Replacing fluids and fuels as well as parts according to due date and recommendations for vehicle decommissioning longer than 1 year.

The actual scope of the actions can be individually designed at its own discretion and depending on the customer's vehicle usage profile.

It must always be noted that corresponding test points are processed directly as part of the APA3 action, where possible, in order to make the best possible use of synergies between the respectively required work and to work as cost-effectively as possible.

Please note that there is an accompanying campaign WRH8 that is only used to pay for Carrera GT vehicle transport to and from the Porsche Center. Due to the Stop Drive, Porsche strongly recommends that customers do not drive their vehicle into the Porsche Center for the APA3 remedy.

Installation
Position:

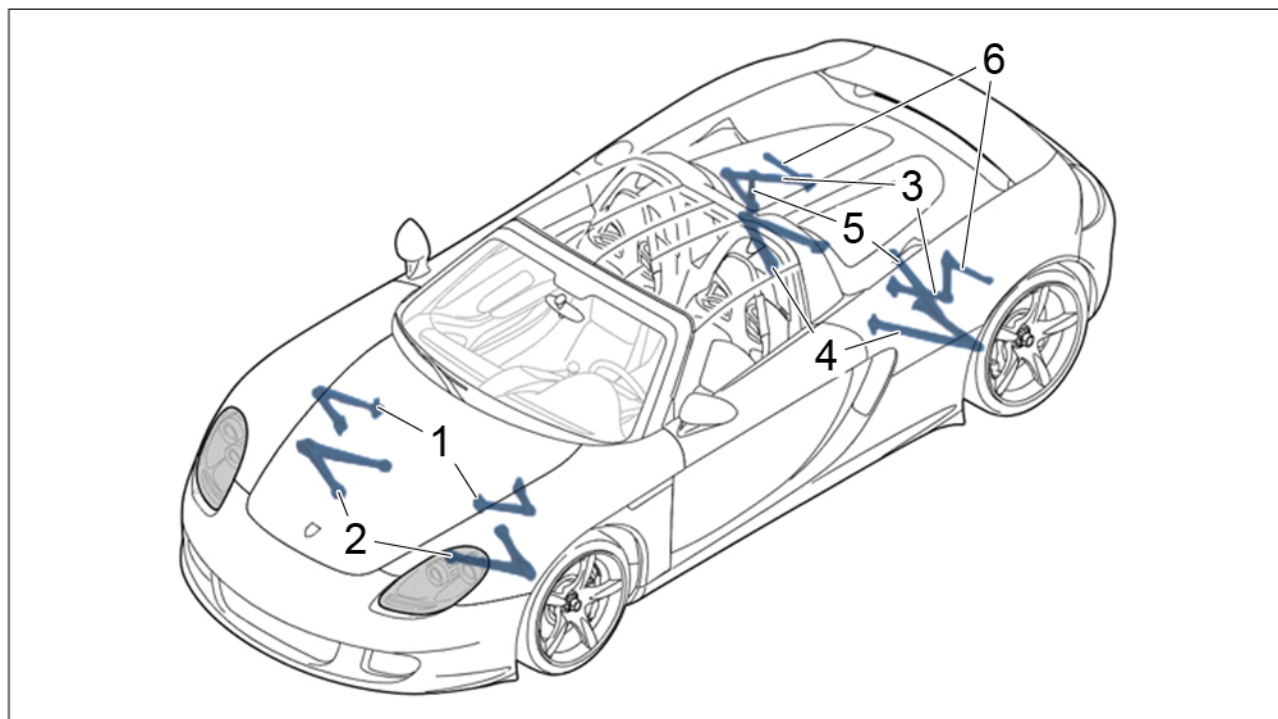

Installation position of relevant chassis parts

- 1 – Wishbone on front axle, upper
- 2 – Wishbone front axle, lower
- 3 – Wishbone on rear axle, upper
- 4 – Wishbone on rear axle, lower
- 5 – Push rod rear axle
- 6 – Tie rod on rear axle

Affected Vehicles: Only vehicles assigned to the campaign (see also PCSS Vehicle Information).

Service Level: This campaign may only be carried out by Porsche Centers that have the necessary tools and appropriately trained and qualified personnel.

Prerequisite for carrying out the APA3 campaign:

- Porsche Centers with a **Carrera GT Service Level 2** and **personnel appropriately trained on Carrera GT**

or

- Porsche Centers with a **certified Porsche technician - Gold** with **completed chassis training and "active" status**

Required parts

Parts Info:

Required parts:

Part No.	Designation – Location	Quantity
V04015005	⇒ Wishbone – Front axle, lower	2 pieces
V04015005AA	⇒ Wishbone – Front axle, upper	2 pieces
V04015005AB	⇒ Wishbone – Rear axle, upper	2 pieces
V04015005AC	⇒ Wishbone – Rear axle, lower	2 pieces
V04015005AH	⇒ (Left-hand threaded) swivel head – Tie rod on rear axle	2 pieces
V04015005AI	⇒ (Right-hand threaded) swivel head – Tie rod on rear axle	2 pieces
99902505030	⇒ Washer 10.2 x 19.5 x 5 – Upper front axle wishbone on body	8 pieces
99902505430	⇒ Washer 12 x 18 x 3.66 – Lower front axle wishbone on body	2 pieces
99902506630	⇒ Washer 10.2 x 19.5 x 3.5 – Lower rear axle wishbone on body	8 pieces
99902505930	⇒ Washer 10.2 x 19.5 x 2.0 – Upper rear axle wishbone on body	8 pieces
V04015005AJ	⇒ Lock nut M10 – Upper front axle wishbone on body – Upper rear axle wishbone on body – Lower rear axle wishbone on body – Rear push rod on deflection lever	26 pieces
V04015005AM	⇒ Lock nut M12 x 1.5 – Upper front axle wishbone on wheel carrier – Lower front axle wishbone on wheel carrier – Upper rear axle wishbone on wheel carrier	6 pieces
90037806910	⇒ Hexagon-head bolt M12 x 1.5 x 85 – Lower front axle wishbone on body	4 pieces
90037830401	⇒ Hexagon-head bolt M12 x 1.5 x 90 – Upper front axle wishbone on wheel carrier – Upper rear axle wishbone on wheel carrier	4 pieces

98033160100	⇒ Fit bolt M10 x 81 – Lower rear axle wishbone on wheel carrier	2 pieces
V04015005AN	⇒ Hexagon nut M10 – Rear tie rod on wheel carrier – Rear push rod on wheel carrier	4 pieces
90037813309	⇒ Hexagon-head bolt M10 x 60 – Rear tie rod on wheel carrier	2 pieces
90003100506	⇒ Washer – Rear tie rod on wishbone	2 pieces
90007419203	⇒ Hexagon-head bolt M10 x 55 – Rear tie rod on wishbone	2 pieces
99931104902	⇒ Fit bolt M10 x 50 – Push rod rear axle on deflection lever	2 pieces
V04015005AS	⇒ Hexagon-head bolt AM10 x 55 - Push rod rear axle on wheel carrier	2 pieces
99908401601	⇒ Lock nut M10 - Push rod front axle on wishbone	2 pieces
90037810001	⇒ Hexagon-head bolt M10 x 45 - Push rod front axle on wishbone	2 pieces
V04015005AQ	⇒ Expansion rivet – Front lip – Air guide	4 pieces

Additional required parts (depending on the respective push rod variant):

Part No.	Designation – Location	Quantity
V04015005AF *	⇒ Push rod – Right rear axle (standard chassis)	1 piece
V04015005AD *	⇒ Push rod – Left rear axle (standard chassis)	1 piece
or		
V04015005AG *	⇒ Push rod – Rear axle, right – Only for vehicles with raised height (10 mm)	1 piece
V04015005AE *	⇒ Push rod – Rear axle, left – Only for vehicles with raised height (10 mm)	1 piece

**Information**

* To identify whether the vehicle is equipped with a standard or raised chassis, read the spare part number on the push rods or note the additional marking (higher on the variant).

Rear axle push rod, left:

- Part number for standard chassis: 980 333 257 **03**
- Upgrade of part number: 980 333 257 **04**

Rear axle push rod, right:

- Part number for standard chassis: 980 333 258 **03**
- Upgrade of part number: 980 333 258 **04**

In the case of the higher version, a **further marking "H+ 10"** is attached for clear differentiation - in addition to the spare part number - and there is a **10-mm white color ring** in the middle of the push rod.

Please note the Push rods are the only part that is blocked from ordering in PPL. You will need to submit a PPL order and corresponding PRMS Parts Support ticket for release of any APA3 Push rods. Note that only 5% of Carrera GT vehicles sold worldwide (about 60) were ever fitted with the "raised height" push rods. PCNA requires photo documentation of these push rods in order to release. The normal push rods V04015005AF and V04015005AD can be released before the vehicle appointment with a PRMS Parts ticket, but not the raised height parts. Also, please note that the raised height push rods was a Tequipment option and has nothing to do with aftermarket air suspension, which is a common modification for the Carrera GT.

If necessary, required parts (optionally remunerated):

**Information**

If **individual fastening screws** on the underbody covers are damaged, the **damaged screws** must be replaced.

The number depends on the requirements of the respective vehicle.

Please note that it is not planned to replace all screws on the underbody covers on all affected vehicles. The screws can be reused if they are not damaged.

**Information**

Order via part No.	Designation – Location	Quantity
V04015005AL	⇒ Oval-head screw, M6 x 16 – Cover for front underbody – Cover for center underbody – Cover for rear underbody	As required but a maximum of 40 per vehicle

999073254A2	⇒ Oval-head screw, M6 x 30 – Cover for center underbody	As required but a maximum of 9 per vehicle
98034135101	⇒ Spacer plate 1 mm – Front axle camber setting	As required but a maximum of 2 pieces per vehicle
98033135101	⇒ Spacer plate 1 mm – Camber adjustment on rear axle	As required but a maximum of 2 pieces per vehicle
V04015005AP	⇒ Speed nut – Cover for center underbody	As required but a maximum of 4 pieces per vehicle

Materials: **Material required as needed** (optionally remunerated):

Part No.	Designation	Quantity
99991171040	⇒ Sealing strap – Cover for center underbody	1 piece

Required tools

Tools:

Special tools:

Designation/Comment	Location
1 set of drive-on aids, such as 9453 - 9453 - access ramps	Raise the vehicle
9482 - 9482 - Carrier plates	
4-piece strapping belts, e.g. 9454 - 9454 - strapping belts	
9451 - 9451 - Socket wrench	Removing and installing wheels
9450 - 9450 - Torque multiplier *	
Torque wrench, 40-200 Nm (30-148 ftlb.), e.g. V.A.G 1332A - torque wrench, 40-200 Nm (30-148 ftlb.) *	



Information

* As an **alternative** to the torque **multiplier** and **torque wrench 40-200 Nm** (30-148 ftlb), following can be used; a torque wrench covering a range of 550 Nm (406 ftlb), such as **V.A.G 1601 - torque wrench 150-800 Nm (111-590 ftlb)**

Torque wrench, 40-200 Nm (30-148 ftlb.), e.g. V.A.G 1332A - torque wrench, 40-200 Nm (30-148 ftlb.)	Removing and installing wishbone
Transmission jack, e.g. VAS 6931A - Transmission and gearbox jack	
Ball-joint extractor, e.g. 9492 - 9492 - Press-out tool	Remove wishbone front axle, lower
VAS 6828 - Central Locking with Precision Aluminium Spoiler Adapter	Performing suspension alignment of the vehicle
Pin wrench, e.g. 9481 - 9481 - Pin wrench	

Preparatory work



Information

Please note that no link to existing Workshop Manuals from the PCSS is possible in this campaign description.

The background to this is that the existing documents in PCSS were created in another editorial system when the Carrera GT was launched. Against this background, it is not possible to create a link to the necessary Workshop Manuals in this campaign description.

For this reason, the necessary Workshop Manuals for the preparatory and follow-up actions must be opened separately in the PCSS.

Please also note the information that may be listed under the respectively required Workshop Manuals in this document.

- Work Procedure: 1 Connect and switch on the battery charger.
For instructions, see Workshop Manual: **2706 Battery**
- 2 Raise the vehicle.
For instructions, see Workshop Manual: **0X00IN Lifting vehicle**



Information

When lifting the vehicle in addition to the Workshop Manual, observe the following points:

- Before lifting the vehicle, install mounting plates at the lifting points for the lifting platform.
9482 - 9482 - Carrier plates

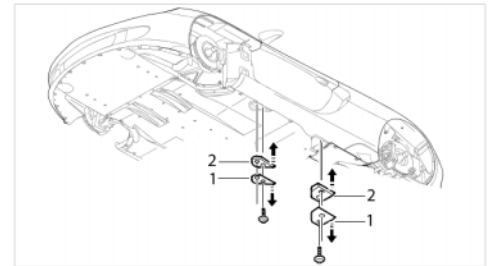

Carrier plates

- Use drive-on aids so that the lifting platform lever arms can be swivelled under the vehicle pick-up points. For example: **9453 - 9453 - Access ramps**

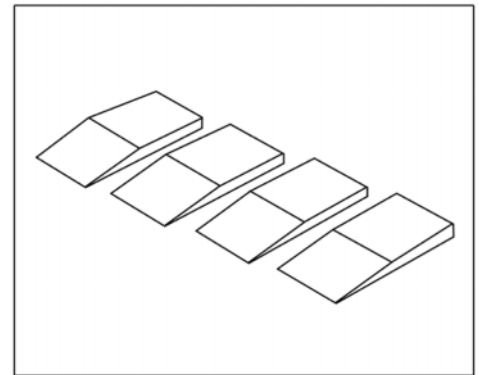

Drive-on aids

- Fasten the vehicle to the lifting platform arms using strapping belts. For example: **9454 - 9454 - Strapping belts**

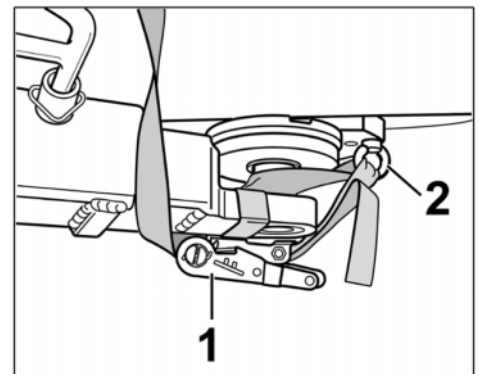

Strapping belt

- Only lift the vehicle fully fuelled and with corresponding weights in the luggage compartment, which are also used for suspension alignment, for example, as the vehicle on the lifting platform is very rear-heavy.
- First, lift the vehicle only a few centimetres and check that the vehicle is standing securely on the lifting platform. Only continue further work if this has been achieved.

- 3 Remove trailing arm on front and rear axle.
For instructions, see Workshop Manual: **440519 Remove and install wheel**

**Information**

As an alternative to the torque multiplier ⇒ *Tyre removal/tyre installation tool overview -B-9450 - 9450 - torque multiplier* and torque wrench ⇒ *Tyre removal/tyre installation tool overview -C-* covering a value of 165 Nm (122 ftlb) as mentioned in the Workshop Manual, a torque wrench covering a value of 550 (406 ftlb) can also be used. For example: **V.A.G 1601 - Torque Wrench 150–800 Nm (111–592 ftlb.)**

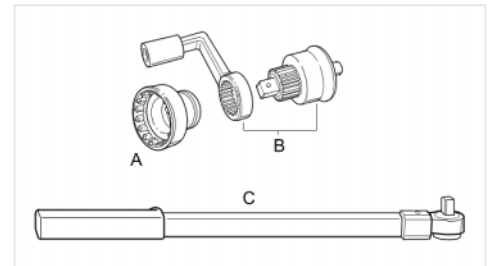

Tyre removal/tyre installation tool overview

- 4 Remove cover for front underbody.
For instructions, see Workshop Manual: **519219 Removing and installing cover for front underbody**
- 5 Remove the cover for the center underbody.
For instructions, see Workshop Manual: **519319 Removing and installing cover for center underbody**
- 6 Remove the cover for the rear underbody.
For instructions, see Workshop Manual: **519419 Removing and installing cover for rear underbody**

Replacing wishbone on front axle**Information**

The procedure described below is described as an example on the right side of the vehicle.
The work procedure on the left side of the vehicle is almost identical.

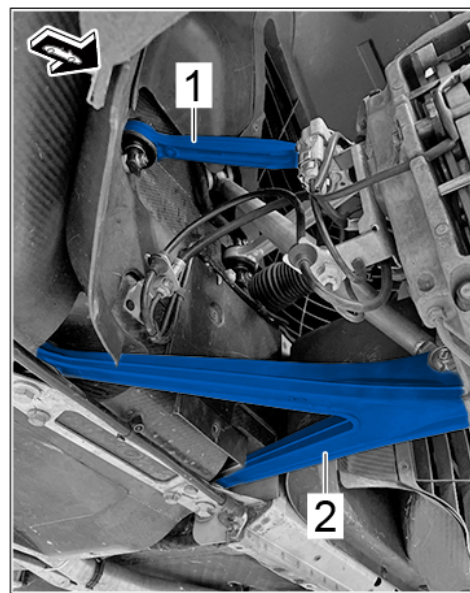

Wishbone front axle

- 1 – Upper wishbone (shown on the right side of the vehicle)
- 2 – Lower wishbone (shown on the right side of the vehicle)

Work Procedure: 1 Remove the wishbone at the **top of the front axle**.

- 1.1 Loosen nut \Rightarrow *Wishbone on front axle, upper -1-* on the wheel carrier. To do so, counter at the screw \Rightarrow *Wishbone on front axle, upper -2-*.

Then loosen and unscrew four nuts \Rightarrow *Wishbone on front axle, upper -3-* on the monocoque.

- 1.2 Remove screw \Rightarrow *Wishbone on front axle, upper -1-* on wheel carrier and remove wishbone.

- 1.3 Check protrusion of the threaded pin in the monocoque.

- **Target dimension 25 ± 1 mm**

If this is too large, the threaded pin may have come loose during the removal of the nut and must be replaced.

If this is too small, it is not possible to ensure safe mounting of the wishbones on the monocoque. In this case, the affected threaded pin must also be replaced.

Observe the Workshop Manual **510141 Repairing body/monocoque**.

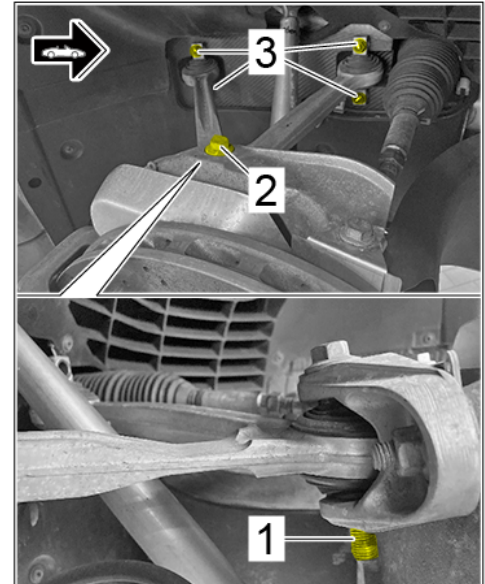

Wishbone on front axle, upper

- 2 Install **new** wishbone on the upper front axle.

- 2.1 Clean the contact surface of the washers on the monocoque and position **new** washers on the threaded pins on the monocoque \Rightarrow *Position washers (example shown on the rear axle)*.

Part No.	Designation	Quantity
99902505030	Washer 10.2 x 19.5 x 5	4 units per vehicle side (left/right front axle)

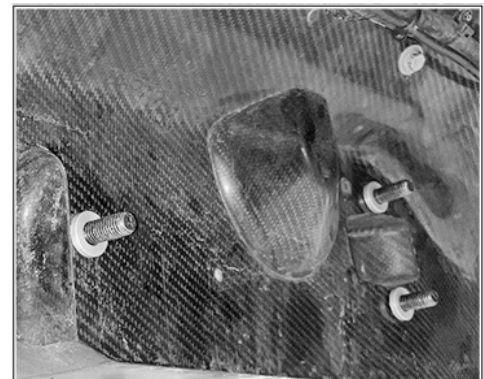

Position washers (example shown on the rear axle)

2.2 Insert **new** wishbone on the threaded pins ⇒ *Wishbone on monocoque -A-* and first secure with **new** nuts ⇒ *Wishbone on monocoque -1-*.

Part No.	Designation	Quantity
V04015005AA	Wishbone on front axle, upper	1 piece each per vehicle side (left/right front axle)
V04015005AJ	Hexagon nut M10	4 units per vehicle side (left/right front axle)

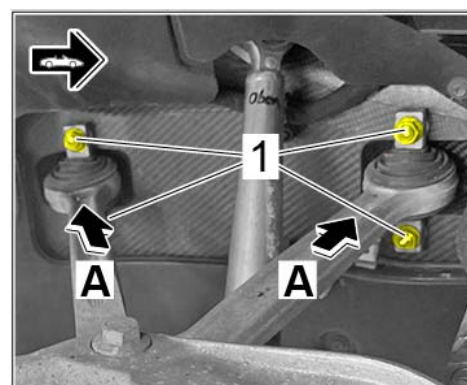

Wishbone on monocoque



Information

To prevent damage to the components, ball joints must be brought into a correct assembly position before installation.

Otherwise, damage to the cuff, ball joint or wheel carrier cannot be ruled out.

Ball joint in assembly position. The track rod of the rear axle is shown as an example.



Ball joint mounting position

Damaged cuff (sample illustration).



Damaged cuff

2.3 Before assembling the wishbone ⇒ *Wishbone to wheel carrier -2-* to the wheel carrier ⇒ *Wishbone to wheel carrier -3-*, align the ball joint on the wishbone in an escape ⇒ *Wishbone to wheel carrier -B-* to the wheel carrier.

2.4 Carefully insert the directional ball joint of the wishbone into the wheel carrier, carefully insert screw ⇒ *Wishbone to wheel carrier -4-* on the wheel carrier and guide it through the wheel carrier and wishbone. Then screw on nut ⇒ *Wishbone to wheel carrier -5-*.

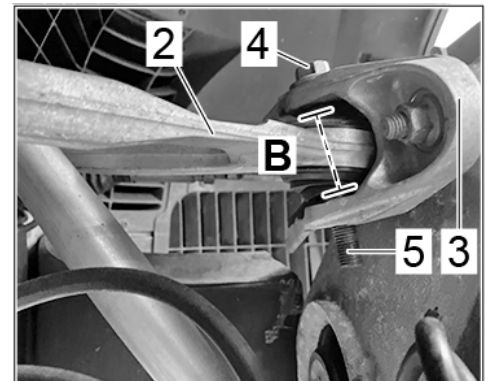

Wishbone to wheel carrier

Part No.	Designation	Quantity
90037830401	Hexagon-head bolt, M12 x 1.5 x 90	1 piece each per vehicle side (left/right front axle)
V04015005AM	Lock nut, M12 x 1.5	1 piece each per vehicle side (left/right front axle)

- 2.5 Tighten nuts ⇒ *Tighten wishbone -3-* on the monocoque and nuts ⇒ *Tighten wishbone -1-* on the screw ⇒ *Tighten wishbone -2-* on the wheel carrier.

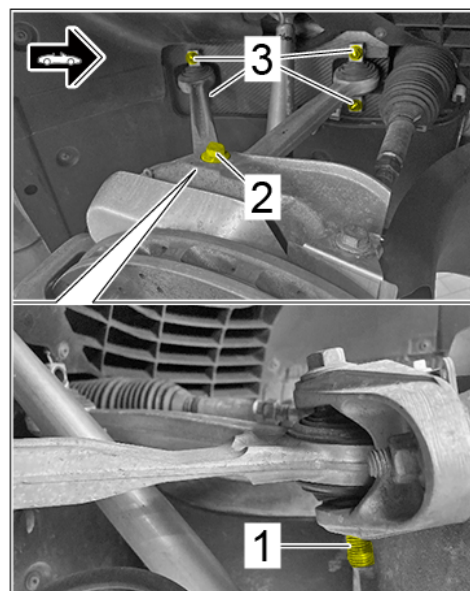

Tighten wishbone

NOTICE

At connection points consisting of the combination of a screw and nut, tighten the nut and hold it against the screw.

- In the event of non-compliance, it cannot be ensured that the required tightening torques are reached

⇒ Tighten nut and counter at screw.

- Upper wishbone at monocoque: Tightening torque 45 Nm (33.2 ftlb.)
- Upper wishbone on wheel carrier: Tightening torque 65 Nm (47.9 ftlb.)

- 3 Replace upper wishbone on the **lower front axle**.

- 3.1 Loosen connecting screw from push rod to wishbone via the nut ⇒ *Loosen wishbone -1-* and unscrew the nut.
Do not remove the screw yet.

- 3.2 Loosen screws ⇒ *Loosen wishbone -2-* on the monocoque, but do **not unscrew them yet**.

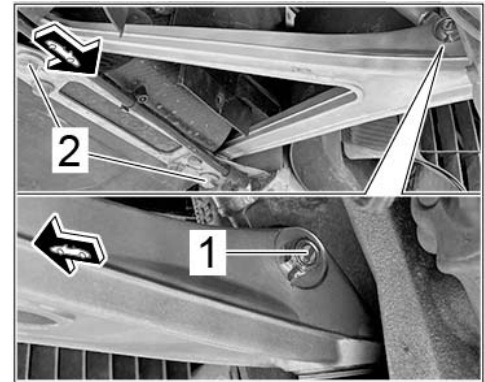

Loosen wishbone

- 3.3 Loosen nut ⇒ *Loosen support joint -3-* on the support joint, attach the press-out tool ⇒ *Loosen support joint -4-* and detach the wishbone from the wheel carrier.
- 3.4 Provide **new** wishbone, **new** fastening screws on the monocoque and **new** connecting screw between wishbone and push rod including **new** nut.

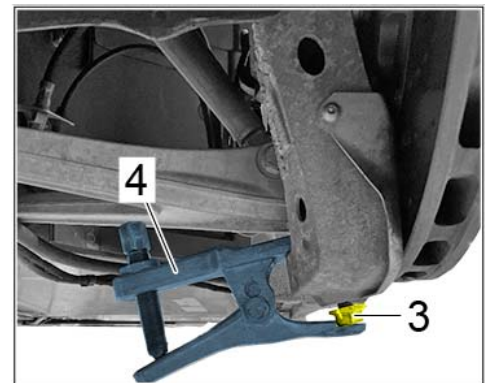

Loosen support joint

Part No.	Designation	Quantity
V04015005	Wishbone front axle, lower	1 piece each per vehicle side (left/right front axle)
90037806910	Hexagon-head bolt, M12 x 1.5 x 85	2 units each per vehicle side (left/right front axle)
99902505430	Washer 12 x 18 x 3.66	1 piece each per vehicle side (left/right front axle)
90037810001	Hexagonal-head bolt, M10 x 45	1 piece each per vehicle side (left/right front axle)
99908401601	Lock nut M10	1 piece each per vehicle side (left/right front axle)
V04015005AM	Lock nut, M12 x 1.5	1 piece each per vehicle side (left/right front axle)

NOTICE

As soon as the connecting screw between the push rod and control arm is removed, the wheel carrier swivels downwards.

- Risk of damage to components
- ⇒ Have a second person help hold the wheel carrier in position and assist in removing and installing the lower transverse control arm.

3.5 Remove nut on support joint ⇒ *Remove wishbone -3-*, both screws on monocoque ⇒ *Remove wishbone -2-* and connecting screw ⇒ *Remove wishbone -5-* between wishbone and push rod. Then pull the wheel carrier outwards ⇒ *Remove wishbone -A-*, swivel the wishbone downwards on the monocoque side ⇒ *Remove wishbone -B-* and guide out of the wheel carrier.

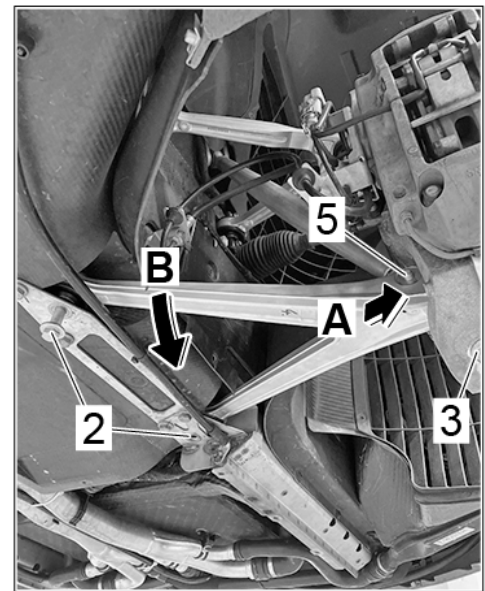

Remove wishbone

- 3.6 Insert **new** wishbone ⇒ *Install wishbone at the wheel carrier -7-* into the wheel carrier and attach nut to ⇒ *Install wishbone at the wheel carrier -3-* the support joint.



Information

To prevent damage to the components, ball joints must be brought into a correct assembly position before installation. Otherwise, damage to the cuff, ball joint or wheel carrier cannot be ruled out.

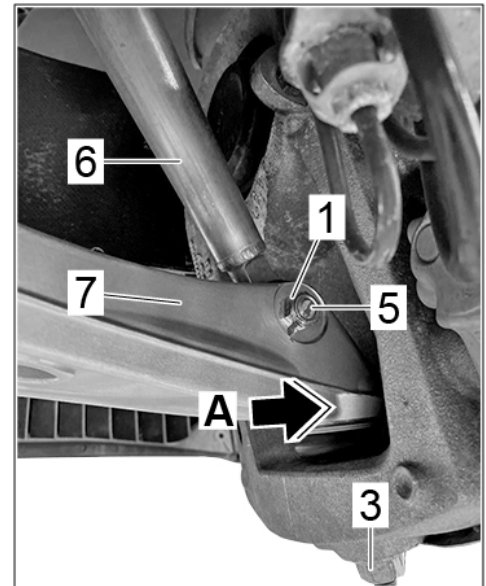

Install wishbone at the wheel carrier

Ball joint in assembly position. The track rod of the rear axle is shown as an example.

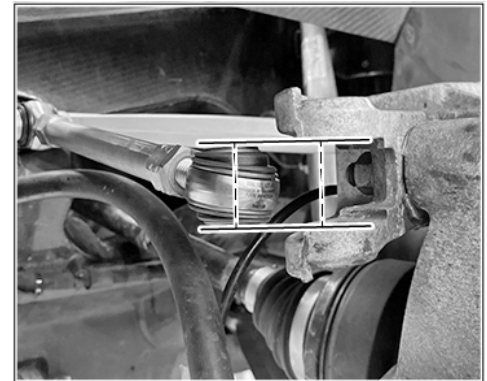

Ball joint mounting position

Damaged cuff (sample illustration).

- 3.7 Pull the wheel carrier outwards ⇒ *Install wishbone at the wheel carrier -A-*, carefully push rod ⇒ *Install wishbone at the wheel carrier -6-* without damaging the collar, insert it into the wishbone ⇒ *Install wishbone at the wheel carrier -7-*, insert the connecting screw ⇒ *Install wishbone at the wheel carrier -5-* between the wishbone and push rod and secure it with the nut ⇒ *Install wishbone at the wheel carrier -1-*.



Damaged cuff

- 3.8 Align both ball joints on the wishbone in an escape to the monocoque. ⇒ *Ball joint aligned*
- 3.9 Insert wheel carrier into the monocoque and position the **washer** ⇒ *Install wishbone on monocoque -8-* under the wishbone in the direction of travel at the rear, between the ball joint and support plate, and attach screws ⇒ *Install wishbone on monocoque -2-.*

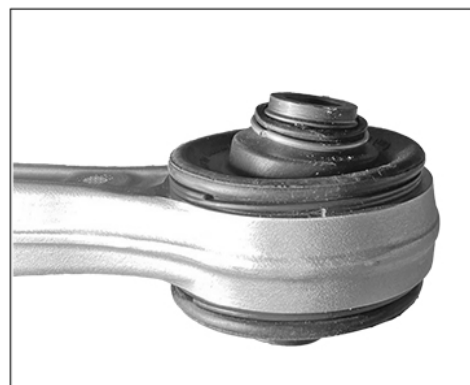

Ball joint aligned

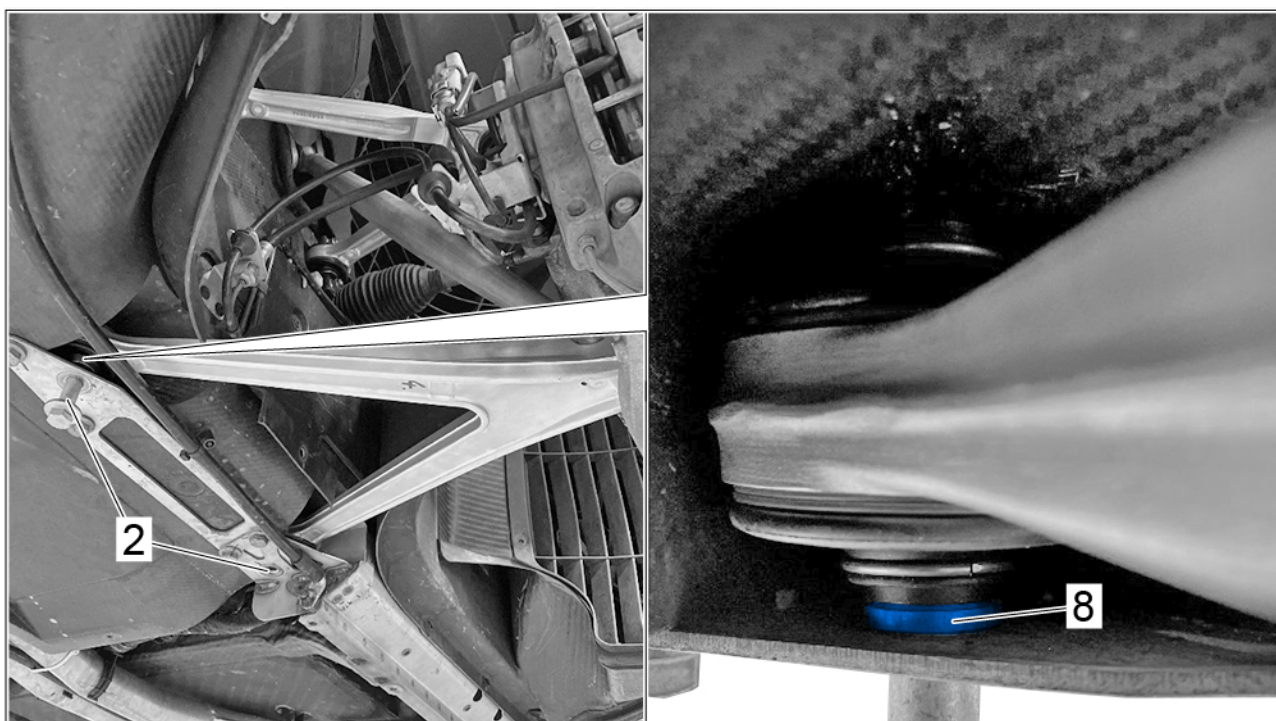

Install wishbone on monocoque

- 3.10 Tighten screws on the monocoque, connecting screw between wishbone and push rod and nut on the support joint.

NOTICE

At connection points consisting of the combination of a screw and nut, tighten the nut and hold it against the screw.

- In the event of non-compliance, it cannot be ensured that the required tightening torques are reached

⇒ Tighten nut and counter at screw.

- Lower wishbone on monocoque: Tightening torque 65 Nm (47.9 ftlb.)
- Push rod to wishbone: Tightening torque 35 Nm (25.8 ftlb.)
- Lower wishbone on wheel carrier: Tightening torque 55 Nm (40.6 ftlb.)

4 Repeat the procedure on the left side of the vehicle.

Replace wishbone, push rod and tie rod joints on the rear axle



Information

The procedure described below is described as an example on the right side of the vehicle.
The work procedure on the left side of the vehicle is almost identical.

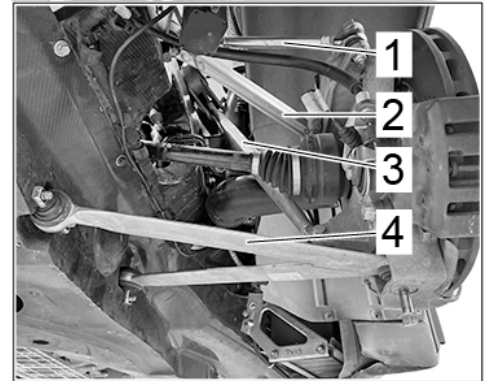

*Wishbone, push rod and tie rod
on the rear axle*

- 1 – Lane rod including tie rod heads *
- 2 – Upper wishbone *
- 3 – Push rod *
- 4 – Lower wishbone *

* Shown on the right side of the vehicle.

Work Procedure: 1 Remove wishbone on the **upper rear axle including tie rod**.

1.1 Loosen nut ⇒ *Loosen top wishbone -1-* and ⇒ *Loosen top wishbone -2-* on wheel carrier and unscrew nuts ⇒ *Loosen top wishbone -3-* on monocoque.

1.2 Remove screw ⇒ *Loosen top wishbone -4-* and ⇒ *Loosen top wishbone -5-* from wheel carrier.

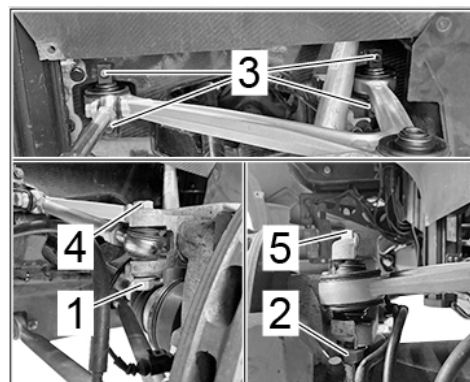

Loosen top wishbone

1.3 Swivel wheel carrier outwards ⇒ *Removing upper wishbone -A-* and then ⇒ *Removing upper wishbone -B-* remove the wishbone including tie rod outwards.

2 Replace tie rod joints.

2.1 Mark the inside and/or outside of the tie rod with a pin or adhesive tape so that a mirror-inverted installation is prevented during reassembly.

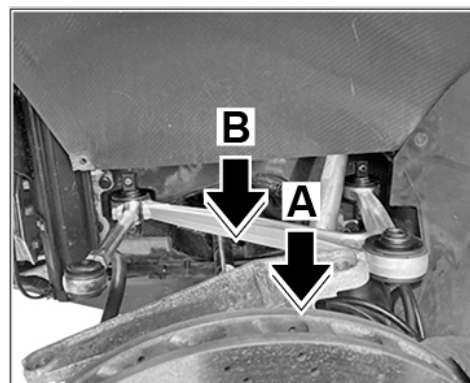

Removing upper wishbone

2.2 Unscrew screw ⇒ *Removing tie rod -1-* and remove tie rod from wishbone.

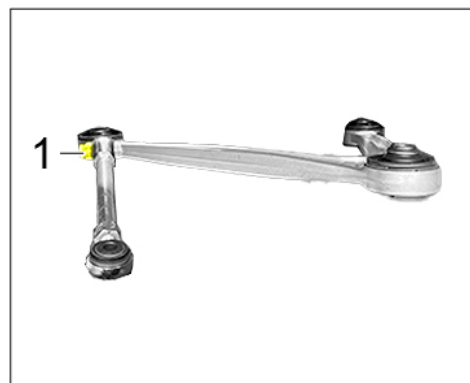

Removing tie rod

- 2.3 Mark the length of the tie rod either on an assembly device ⇒ *Determine tie rod length -A-* (if available) or on a sheet of paper with a pin ⇒ *Determine tie rod length -B-*. For this purpose, for example, record the outer outlines of the tie rod and document the length. The more precise the work is done, the lower the required adjustment for vehicle alignment will be later.
- 2.4 Loosen lock nuts ⇒ *Convert the tie rod -1-* on the tie rod and unscrew the tie rod heads ⇒ *Convert the tie rod -2-* from the tie rod.

**Information**

The tie rod and lock nuts are reused.

- 2.5 From the **previous** tie rod heads, **unscrew** the lock nuts and have them onto the **new** tie rod heads **screwed**.



Determine tie rod length

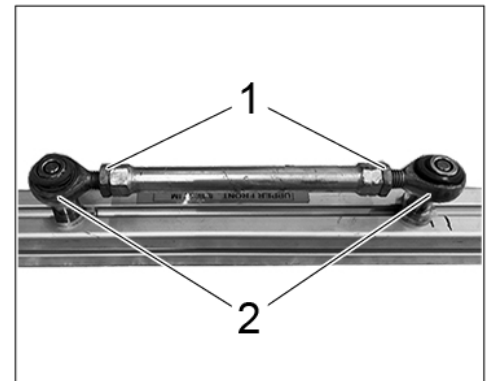

Convert the tie rod

Part No.	Designation - Location	Quantity
V04015005AH	(Left-hand threaded) swivel head - Steering lever (wheel carrier)	1 piece each per vehicle side (left/right front axle)
V04015005AI	(Right-hand threaded) swivel head - Wishbone	1 piece each per vehicle side (left/right front axle)

2.6 Install new tie rod heads ⇒ *Assemble tie rod -2-* into the previous tie rod ⇒ *Assemble tie rod -3-* and adjust them to the required length using the mounting device ⇒ *Assemble tie rod -A-* or using the dimensions previously noted on a sheet of paper ⇒ *Assemble tie rod -B-*.
Then fit the lock nuts, but do not tighten them yet.

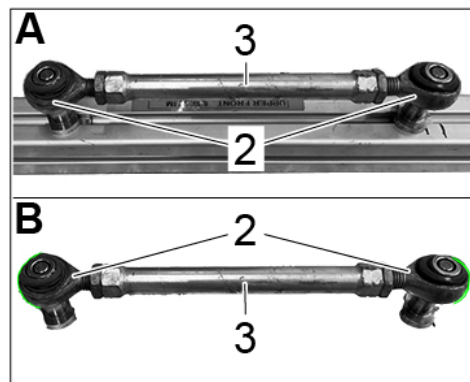

Assemble tie rod

3 Install **new** wishbone and tie rod with **new** joint heads.

3.1 Check protrusion of the threaded pin in the monocoque.

- **Target dimension 24 ± 1 mm**

If this is too large, the threaded pin may have come loose during the removal of the nut and must be replaced.

If this is too small, it is not possible to ensure safe mounting of the wishbones on the monocoque. In this case, the affected threaded pin must also be replaced.

Observe the Workshop Manual **530241 Repairing rear body (engine mount)**.

3.2 Clean the contact surface of the washers on the monocoque and position **new** washers on the threaded pins on the monocoque ⇒ *Positioning washers*.

Part No.	Designation	Quantity
99902505930	Washer 10.2 x 19.5 x 2.0	4 units each per vehicle side (left/right front axle)

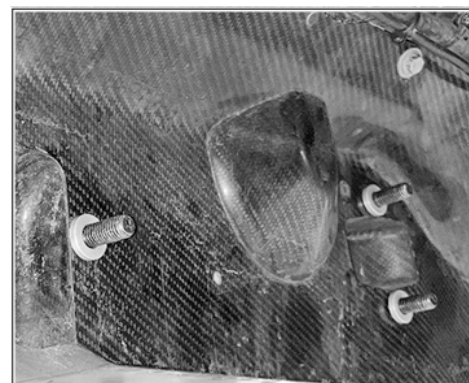

Positioning washers

3.3 Insert new wishbone onto the threaded pins and screw ⇒ *Install wishbone and tie rod -1-* them in using the new nuts.

Part No.	Designation	Quantity
V04015005AB	Wishbone on rear axle, upper	1 piece per vehicle side (left/right rear axle)
V04015005AJ	Lock nut M10	4 pieces per vehicle side (left/right rear axle)

- **Wishbone on monocoque: tightening torque 45 Nm (33.2 ftlb.)**

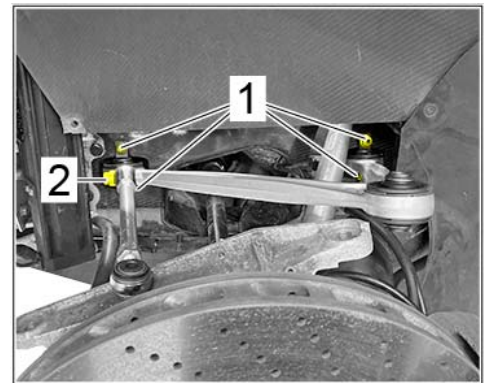

Install wishbone and tie rod

- 3.4 Position tie rod according to the previously set marking (inside and outside) and secure it to the wishbone using the screw ⇒ *Install wishbone and tie rod -2-*.



Information

The new swivel head for connection to the wheel carrier (swivel head with left-hand thread) differs in its geometric shape compared to the previous swivel head. The bearing width of the new swivel head has been reduced from 12 mm to 10 mm due to a new sealing concept. Against this background, it must be ensured that the 10 mm wide swivel head (swivel head with left-hand thread) is installed on the wheel carrier. For this, if necessary, the track rod must be installed the other way around, contrary to the previously set marking.

Part No.	Designation	Quantity
90007419203	Hexagon-head bolt, M10 x 55	1 piece per vehicle side (left/right rear axle)
90003100506	Washer	1 piece per vehicle side (left/right rear axle)



Information

To prevent damage to the components, ball joints must be brought into a correct assembly position before installation.

Otherwise, damage to the cuff, ball joint or wheel carrier cannot be ruled out.

Ball joint in assembly position. The track rod of the rear axle is shown as an example.

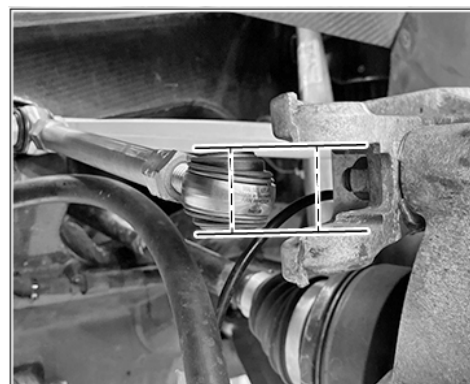

Ball joint mounting position

Damaged cuff (sample illustration).

- 3.5 Align the ball joint on the wishbone with the wheel carrier, and carefully insert it into the wheel carrier without damaging the cuff. Then insert screw ⇒ *Wishbone and track rod on upright -5-* and screw on nut ⇒ *Wishbone and track rod on upright -6-*.



Damaged cuff

Part No.	Designation	Quantity
90037830401	Hexagon-head bolt, M12 x 1.5 x 90	1 piece
V04015005AM	Lock nut, M12 x 1.5	1 piece

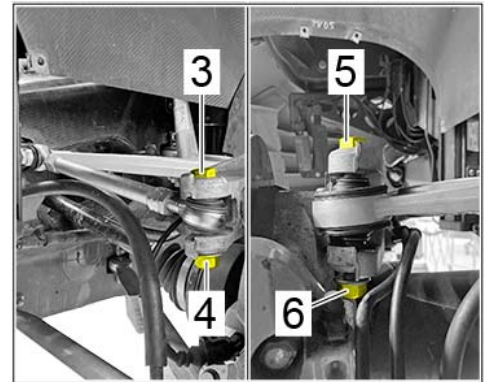

Wishbone and track rod on upright

- 3.6 Align the ball joint on the tie rod to the wheel carrier and carefully insert it into the wheel carrier without damaging the cuff.
Then insert screw \Rightarrow *Wishbone and track rod on upright -3-* and screw on nut \Rightarrow *Wishbone and track rod on upright -4-*.
- 3.7 Tighten the lock nuts on tie rod \Rightarrow *Tighten tie rod and wishbone -1-*, the screw with the nut on rear wheel carrier \Rightarrow *Tighten tie rod and wishbone -3 and 4-*, the screw with the nut on front wheel carrier \Rightarrow *Tighten tie rod and wishbone -5 and 6-* and screw \Rightarrow *Tighten tie rod and wishbone -2-*.

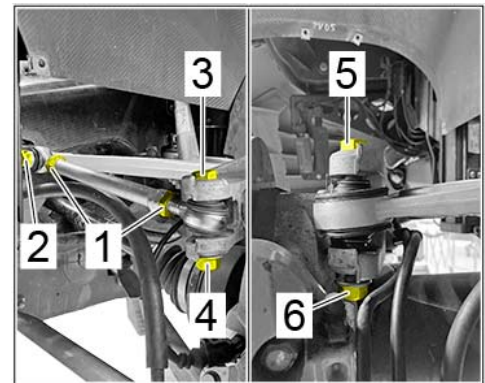

Tighten tie rod and wishbone

NOTICE

At connection points consisting of the combination of a screw and nut, tighten the nut and hold it against the screw.

- In the event of non-compliance, it cannot be ensured that the required tightening torques are reached

\Rightarrow Tighten nut and counter at screw.

- Lock nuts on tie rod: Tightening torque 50 Nm (36.9 ftlb.)
- Tie rod to wheel carrier: Tightening torque 45 Nm (33.2 ftlb.)
- Tie rod on wishbone: tightening torque 45 Nm (33.2 ftlb.)
- Wishbone to wheel carrier: Tightening torque 65 Nm (47.9 ftlb.)

- 4 Remove push rod and lower wishbone.

- 4.1 Unscrew nut ⇒ *Loosen push rod-1-*, but do not remove the screw ⇒ *Loosen push rod-2-* on the upper push rod **yet**.
- 4.2 Unscrew nut ⇒ *Loosen push rod-3-*, but do not remove the screw ⇒ *Loosen push rod-4-***yet**.

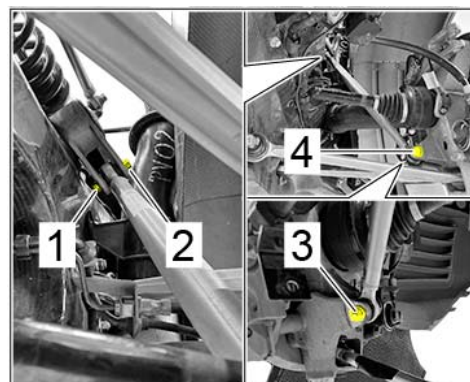

Loosen push rod

- 4.3 Remove screw ⇒ *Loosen wishbone-6-* on wheel carrier and nuts ⇒ *Loosen wishbone-5-* on monocoque.

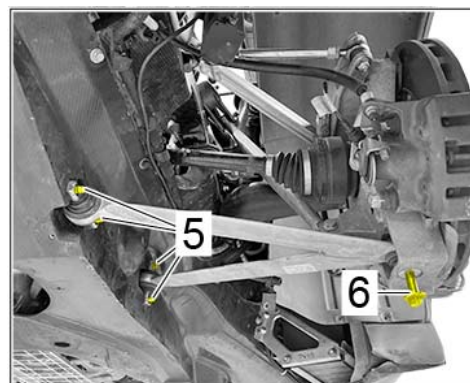

Loosen wishbone

- 4.4 Position the transmission lifter under the wheel carrier ⇒ *Supporting wheel carriers* and support the wheel carrier with the transmission lifter.
To remove and install the push rod and wishbone, engage a **second person** at the bottom to hold the wheel carrier in position on the transmission lifter.

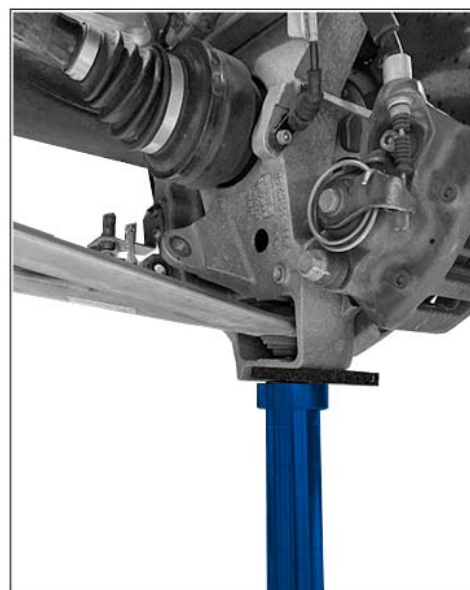

Supporting wheel carriers

- 4.5 Remove screw ⇒ *Removing push rod-1-* and screw ⇒ *Removing push rod-2-* on push rod and remove push rod.

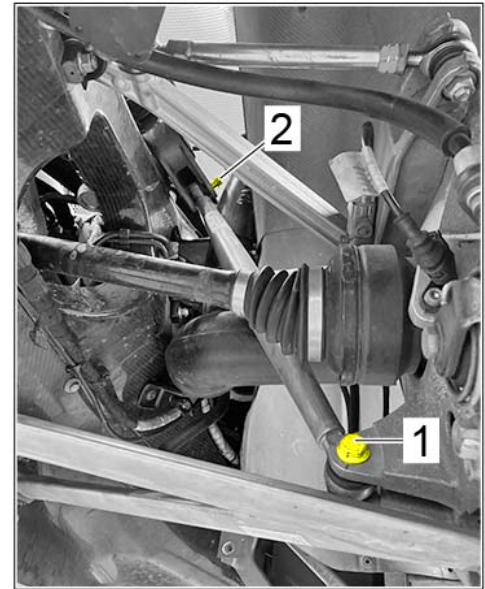

Removing push rod

- 4.6 Swivel wheel carrier outwards with wishbone ⇒ *Removing lower wishbone -A-* until the wishbone is extended from the threaded pins on the monocoque. Then fold the wheel carrier down at the side of the monocoque ⇒ *Removing lower wishbone -B-* and guide it out of the wheel carrier.

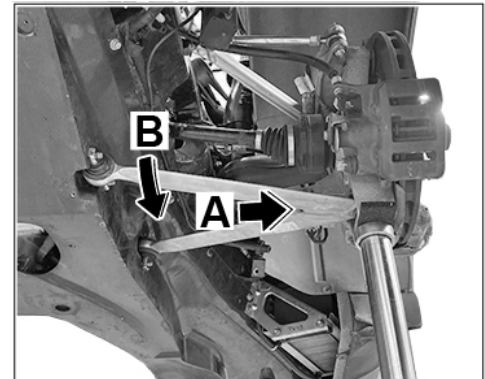

Removing lower wishbone

- 5 Install **new** push rod.

Part No.	Designation	Quantity
V04015005AF*	Push rod, right	1 piece
V04015005AD*	Push rod, left	1 piece
or		
V04015005AG*	Push rod, right – Only for vehicles with raised height (10 mm)	1 piece
V04015005AE*	Push rod, left – Only for vehicles with raised height (10 mm)	1 piece



Information

* Select the appropriate push rod depending on the vehicle's vehicle equipment.

To identify whether the vehicle is equipped with a standard or raised chassis, read the spare part number on the push rods or note the additional marking (higher on the variant).

Rear axle push rod, left:

- Part number for standard chassis: 980 333 257 **03**
- Upgrade of part number: 980 333 257 **04**

Rear axle push rod, right:

- Part number for standard chassis: 980 333 258 **03**
- Upgrade of part number: 980 333 258 **04**

In the case of the higher version, a **further marking "H+ 10"** is attached for clear differentiation - in addition to the spare part number - and there is a **10-mm white color ring** in the middle of the push rod.

- 5.1 Carefully insert the new push rod ⇒ *Install push rod at the top -1-* into the deflection lever (rocker) ⇒ *Install push rod at the top -2-* from below without damaging the push rod cuff and fix it with the new screw ⇒ *Install push rod at the top -3-*.



Information

Wet the fit bolt on the shaft, **not on the thread**, with a thin grease film, e.g. 00004330606 - Grease

This makes installation easier and, if applicable, "scratch marks" on the shaft of the fit bolt are avoided.

Part No.	Designation	Quantity
99931104902	Fit bolt, M10 x 50	1 piece per vehicle side (left/right rear axle)

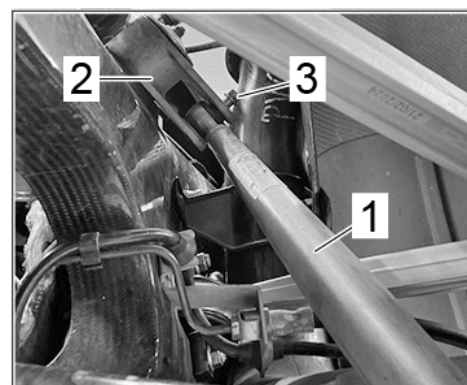

Install push rod at the top

- 5.2 ⇒ *Install push rod-1-* Carefully insert the push rod into the wheel carrier at the bottom without damaging the push rod collar and ⇒ *Install push rod-2-* secure it with the new screw.
Screw and tighten nut ⇒ *Install push rod-4-* on push rod upper and nut ⇒ *Install push rod-3-* on push rod lower.

Part No.	Designation - Location	Quantity
V04015005AS	Hexagon-head bolt, AM10 x 55	1 piece per vehicle side (left/right rear axle)
V04015005AN	Hexagon nut M10 - Wheel carrier	1 piece per vehicle side (left/right rear axle)
V04015005AJ	Lock nut M10 - Reversing lever	1 piece per vehicle side (left/right rear axle)

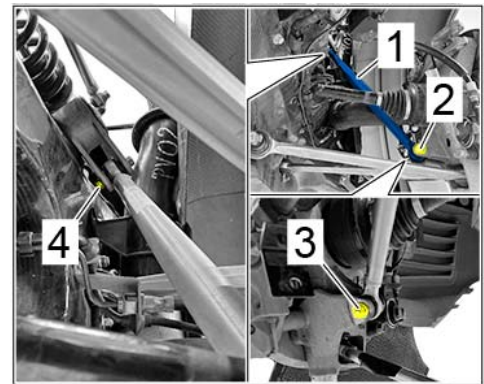

Install push rod

NOTICE

At connection points consisting of the combination of a screw and nut, tighten the nut and hold it against the screw.

- In the event of non-compliance, it cannot be ensured that the required tightening torques are reached

⇒ Tighten nut and counter at screw.

- Push rod on deflection lever: Tightening torque 35 Nm (25.8 ftlb.)
- Push rod to wheel carrier: Tightening torque 35 Nm (25.8 ftlb.)

6 Install **new** lower wishbone.

6.1 Check protrusion of the threaded pin in the monocoque.

- Target dimension 24 ± 1 mm

If this is too large, the threaded pin may have come loose during the removal of the nut and must be replaced.

If this is too small, it is not possible to ensure safe mounting of the wishbones on the monocoque. In this case, the affected threaded pin must also be replaced.

Observe the Workshop Manual **530241 Repairing rear body (engine mount)**.

- 6.2 Clean the contact surface of the washers on the monocoque and position **new** washers on the threaded pins on the monocoque ⇒ *Positioning washers*.

Part No.	Designation	Quantity
99902506630	Washer 10.2 x 19.5 x 3.5	4 pieces per vehicle side (left/right rear axle)

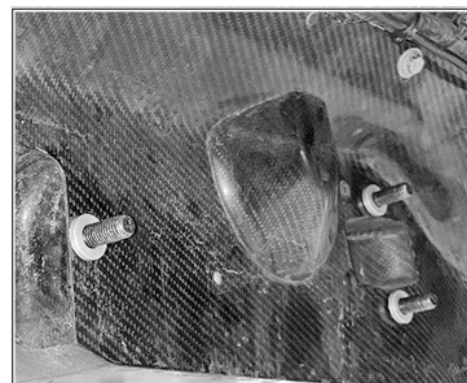

Positioning washers



Information

To prevent damage to the components, ball joints must be brought into a correct assembly position before installation.

Otherwise, damage to the cuff, ball joint or wheel carrier cannot be ruled out.

Ball joint in assembly position. The track rod of the rear axle is shown as an example.

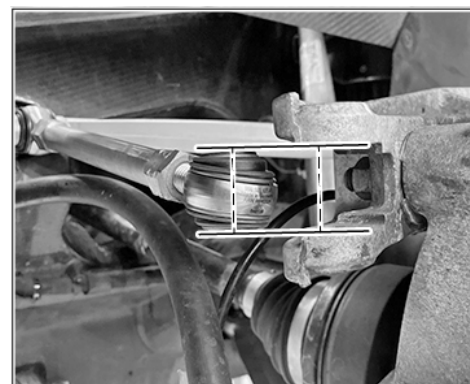

Ball joint mounting position

Damaged cuff (sample illustration).

- 6.3 Align the ball joint of the new wishbone with the wheel carrier, insert the wishbone into the wheel carrier and attach screw ⇒ *Install transverse control arm at the wheel carrier.*
-1-



Information

Wet the fit bolt on the shaft, **not on the thread**, with a thin grease film, e.g.

00004330606 - Grease

This makes installation easier and, if applicable, "scratch marks" on the shaft of the fit bolt are avoided.



Damaged cuff

Part No.	Designation	Quantity
V04015005AC	Wishbone on rear axle, lower	1 piece per vehicle side (left/right rear axle)
98033160100	Fit bolt, M10 x 81	1 piece per vehicle side (left/right rear axle)

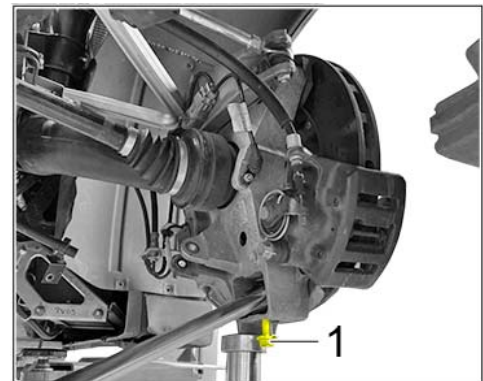

Install transverse control arm at the wheel carrier.

Protect wishbones with 2 layers of standard adhesive tape ⇒ *Protect wishbone -1-*, as this can rub on the push rod during installation.

- 6.4 Remove the transmission lifter under the wheel carrier and pull the wheel carrier with the wishbone outwards ⇒ *Install wishbone -A-*. Then swivel the wishbone up on the monocoque ⇒ *Install wishbone -B-*, insert it on threaded pins ⇒ *Install wishbone -C-* and screw on nuts ⇒ *Install wishbone -1-*.

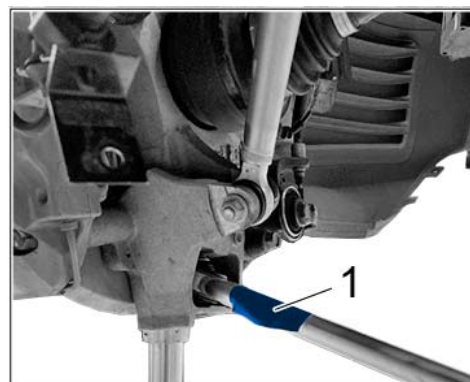

Protect wishbone

Part No.	Designation	Quantity
V04 015 005 AJ	Lock nut M10	4 pieces per vehicle side (left/right rear axle)

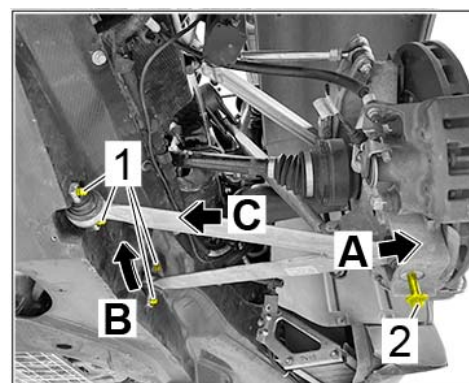

Install wishbone

- 6.5 Tighten nuts ⇒ *Install wishbone -1-* and screw ⇒ *Install wishbone -2-*.
- **Wishbone on monocoque:** Tightening torque 45 Nm (33.2 ftlb.)
 - **Wishbone to wheel carrier:** Tightening torque 50 Nm (36.9 ftlb.)
- 6.6 Remove adhesive tape from lower wishbone.
- 6.7 Repeat the procedure on the left side of the vehicle.

Follow-up actions

Work Procedure: 1 Perform vehicle check (optional).

**Information**

Due to the Stop Use and the associated holding time of the vehicles, Porsche has the option when carrying out the campaign of performing, at the customer's request, either a comprehensive vehicle check or pending maintenance service at prorated cost sharing. Porsche offers a maximum cost sharing of \$ 3,240 per vehicle.

With regard to the scope of the vehicle check, the following criteria and test points can be used as a guide:

- Test points according to the specifications for annual or minor service.
- Replacing fluids and fuels as well as parts according to due date and recommendations for vehicle decommissioning longer than 1 year.

The actual scope of the actions can be individually designed at its own discretion and depending on the customer's vehicle usage profile.

It must always be noted that corresponding test points are processed directly as part of the APA3 action, where possible, in order to make the best possible use of synergies between the respectively required work and to work as cost-effectively as possible.

- 2 Install the cover for the rear underbody.
For instructions, see Workshop Manual: **519419 Removing and installing cover for rear underbody**
- 3 Install the center underbody cover.
For instructions, see Workshop Manual: **519319 Removing and installing cover for center underbody**
- 4 Install cover for front underbody.
For instructions, see Workshop Manual: **519219 Removing and installing cover for front underbody**
- 5 Install wheels on the front and rear axles.
For instructions, see Workshop Manual: **440519 Remove and install wheel**

**Information**

When installing the front and rear wheels, fit the measuring adapters for the vehicle alignment directly.

VAS 6828 - Central Locking with Precision Aluminium Spoiler Adapter

Measurement adapter on wheel **Tightening torque 120 Nm (88.5 ftlb.)**

For instructions, see Workshop Manual: **44 Suspension alignment**

- 6 Lower the vehicle.
For instructions, see Workshop Manual: **OX00IN Lifting vehicle**
- 7 Switch off and disconnect the battery charger.

- 8 Perform front and rear alignment and adjust if necessary.
For instructions, see Workshop Manual: **44 Suspension alignment**
- 9 Remove the adapter for measured value recording and fit wheel nuts.
For instructions, see Workshop Manual: **440519 Remove and install wheel**
- 10 Remove vehicle support plates.
For instructions, see Workshop Manual: **0X00IN Lifting vehicle**
- 11 Test-drive the vehicle according to the criteria for carrying out a test drive as part of the service and also observe the following instructions:
 - Only allow the service advisor or mechanic with the appropriate qualification and experience (e.g. workshop manager) to test-drive the vehicle
 - Check vehicle for unusual handling behavior, vibrations and noises



Information

Please note that the ball joints of the new trailing arms on the front and rear axle require a certain run-in time, analogous to the original delivery condition of the vehicle.

Although the usual precision of the Carrera GT driving behavior has been ensured again with the new components, a certain retraction time can be required until the original usual driving behavior is reproduced.

Please also inform your customer about this issue.

- 12 When the test drive is successfully completed, read out and erase fault memories.
- 13 Enter the campaign in the Warranty and Maintenance logbook for the vehicle.

Warranty processing

Service Level: This campaign may only be carried out by Porsche Centers that have the necessary tools and appropriately trained and qualified personnel.

Prerequisite for carrying out the APA3 campaign:

- Porsche Centers with a **Carrera GT Service Level 2** and **personnel appropriately trained on Carrera GT**

or

- Porsche Centers with a **certified Porsche technician - Gold** with **completed chassis training and "active" status**

Further information on dual processing can be found in the campaign description for workshop campaign WRH8:

⇒ *Technical Information 'WRH8 Workshop campaign - Accompanying actions for replacing the axle control arms on front and rear axles'*

Vehicle check: A maximum amount of up to \$3,240 can be claimed for the vehicle check in the campaign claim. Please attach a corresponding invoice copy with the list of the required parts and the respective labor positions to the campaign claim.



Information

The specified working times were determined specifically for carrying out this campaign and may differ from the working times published in the Labor Operation List in PCSS.

Scope 1: Replacing axle struts on front and rear axles

- Push rod standard version (standard chassis)
- Porsche Center (PC) is also the assigned customer PC (transport cost accounting via WRH8)

Labor time:

Replacing axle struts on front and rear axles

Labor time: **1190 TU**

Includes:

- Connecting and disconnecting battery charger
- Installing carrier plates and strapping vehicle to lifting platform
- Removing and installing wheels
- Remove and install front, center and rear underbody panelling
- Replace push rod rear left and right
- Convert track lugs and replace tie rod heads
- Installing adapter for measured value recording to wheels
- Measure front and rear vehicle
- Adjusting track, camber and vehicle height
- Perform a test drive
- Read out and delete fault memory

Required parts:

Part No.	Designation	Quantity
V04015005	Wishbone	2 pieces
V04015005AA	Wishbone	2 pieces
V04015005AB	Wishbone	2 pieces
V04015005AC	Wishbone	2 pieces
V04015005AF	Push rod	1 piece
V04015005AD	Push rod	1 piece
V04015005AH	(Left-hand threaded) swivel head	2 pieces

V04015005AI	(Right-hand threaded) swivel head	2 pieces
99902505030	Washer 10.2 x 19.5 x 5	8 pieces
99902505430	Washer 12 x 18 x 3.66	2 pieces
99902506630	Washer 10.2 x 19.5 x 3.5	8 pieces
99902505930	Washer 10.2 x 19.5 x 2.0	8 pieces
V04015005AJ	Lock nut M10	26 pieces
V04015005AM	Lock nut, M12 x 1.5	6 pieces
90037830401	Hexagon-head bolt, M12 x 1.5 x 90	4 pieces
90037806910	Hexagon-head bolt, M12 x 1.5 x 85	4 pieces
99908401601	Lock nut M10	2 pieces
90037810001	Hexagonal-head bolt, M10 x 45	2 pieces
98033160100	Fit bolt, M10 x 81	2 pieces
V04015005AN	Hexagon nut M10	4 pieces
90037813309	Hexagon-head bolt, M10 x 60	2 pieces
90003100506	Washer	2 pieces
90007419203	Hexagon-head bolt, M10 x 55	2 pieces
99931104902	Fit bolt, M10 x 50	2 pieces
V04015005AS	Hexagon-head bolt, AM10 x 55	2 pieces
V04015005AQ	Expansion rivet	4 pieces
Material required as needed (optional remuneration):		
99991171040	Sealing strap	1 piece
Additional parts required as needed (optional remuneration):		
V04015005AL	Oval-head screw, M6 x 16	As required but a maximum of 40 per vehicle
999073254A2	Oval-head screw, M6 x 30	As required but a maximum of 9 per vehicle

98034135101	Spacer plates 1 mm	As required but a maximum of 2 per vehicle
98033135101	Spacer plates 1 mm	As required but a maximum of 2 per vehicle
V04015005AP	Speed nut	As required but a maximum of 4 per vehicle

Proportionate assumption of costs

APA30000001*	Vehicle check	Quantity as required (for warranty invoicing only)
--------------	---------------	---

* For warranty processing, **part No. APA30000001** can be invoiced in the warranty claim as an **additional part** with the designation "Vehicle check". Maximum amount \$ 3,240.

⇒ **Damage number APA3 099 000 2**

Scope 2:

Replacing axle struts on front and rear axles

- Push rod (pressure rod) with 10 mm extension (vehicle heightening)
- Porsche Center (PC) is also the assigned customer PC (transport cost accounting via WRH8)

Labor time:

Replacing axle struts on front and rear axles

Labor time: **1190 TU**

Includes:

- Connecting and disconnecting battery charger
- Installing carrier plates and strapping vehicle to lifting platform
- Removing and installing wheels
- Remove and install front, center and rear underbody panelling
- Replace push rod rear left and right
- Convert track lugs and replace tie rod heads
- Installing adapter for measured value recording to wheels
- Measure front and rear vehicle
- Adjusting track, camber and vehicle height
- Perform a test drive
- Read out and delete fault memory

Required parts:

Part No.	Designation	Quantity
V04015005	Wishbone	2 pieces
V04015005AA	Wishbone	2 pieces

V04015005AB	Wishbone	2 pieces
V04015005AC	Wishbone	2 pieces
V04015005AG	Push rod	1 piece
V04015005AE	Push rod	1 piece
V04015005AH	(Left-hand threaded) swivel head	2 pieces
V04015005AI	(Right-hand threaded) swivel head	2 pieces
99902505030	Washer 10.2 x 19.5 x 5	8 pieces
99902505430	Washer 12 x 18 x 3.66	2 pieces
99902506630	Washer 10.2 x 19.5 x 3.5	8 pieces
99902505930	Washer 10.2 x 19.5 x 2.0	8 pieces
V04015005AJ	Lock nut M10	26 pieces
V04015005AM	Lock nut, M12 x 1.5	6 pieces
90037830401	Hexagon-head bolt, M12 x 1.5 x 90	4 pieces
90037806910	Hexagon-head bolt, M12 x 1.5 x 85	4 pieces
99908401601	Lock nut M10	2 pieces
90037810001	Hexagonal-head bolt, M10 x 45	2 pieces
98033160100	Fit bolt, M10 x 81	2 pieces
V04015005AN	Hexagon nut M10	4 pieces
90037813309	Hexagon-head bolt, M10 x 60	2 pieces
90003100506	Washer	2 pieces
90007419203	Hexagon-head bolt, M10 x 55	2 pieces
99931104902	Fit bolt, M10 x 50	2 pieces
V04015005AS	Hexagon-head bolt, AM10 x 55	2 pieces
V04015005AQ	Expansion rivet	4 pieces
Material required as needed (optional remuneration):		
99991171040	Sealing strap	1 piece

Additional parts required as needed (optional remuneration):

V04015005AL	Oval-head screw, M6 x 16	As required but a maximum of 40 per vehicle
999073254A2	Oval-head screw, M6 x 30	As required but a maximum of 9 per vehicle
98034135101	Spacer plates 1 mm	As required but a maximum of 2 per vehicle
98033135101	Spacer plates 1 mm	As required but a maximum of 2 per vehicle
V04015005AP	Speed nut	As required but a maximum of 4 per vehicle

Proportionate assumption of costs

APA30000001 *	Vehicle check	Quantity as required (for warranty invoicing only)
---------------	---------------	---

* For warranty processing, **part No. APA30000001** can be invoiced in the warranty claim as an **additional part** with the designation "Vehicle check". Maximum amount \$ 3,240.

⇒ Damage number APA3 099 000 2

Scope 3: **Not relevant for the US Market**

Scope 4: **Not relevant for the US Market**

Important Notice: Technical Bulletins issued by Porsche Cars North America, Inc. are intended only for use by professional automotive technicians who have attended Porsche service training courses. They are written to inform those technicians of conditions that may occur on some Porsche vehicles, or to provide information that could assist in the proper servicing of a vehicle. Porsche special tools may be necessary in order to perform certain operations identified in these bulletins. Use of tools and procedures other than those Porsche recommends in these bulletins may be detrimental to the safe operation of your vehicle, and may endanger the people working on it. Properly trained Porsche technicians have the equipment, tools, safety instructions, and know-how to do the job properly and safely. Part numbers listed in these bulletins are for reference only. The work procedures updated electronically in the Porsche PIWIS diagnostic and testing device take precedence and, in the event of a discrepancy, the work procedures in the PIWIS Tester are the ones that must be followed.

© 2024 Porsche Cars North America, Inc.