



## STAR ONLINE PUBLICATION



**Case Number: S2403000004**

**Release Date:** October 2024

**Symptom/Vehicle Issue:** Tapping, Knocking Type Noise/Vibration While Driving.

**Discussion:** Some customers may experience a tapping or knocking type noise and vibration coming from under the vehicle. This condition can be felt mainly in the center of the vehicle and typically happens around 40 mph (65 kph). Additionally, the condition happens both under load and during coast down.

The issue may be a misalignment of the driveshaft to Rear Drive Unit (RDU) and/or driveshaft to Transfer Case. If the technician is working on a vehicle with the above condition, please refer to the following repair procedure before replacing any parts.

### **Repair Procedure:**

1. On a suitable hoist, raise and support the vehicle.
2. Inspect and locate the yellow alignment marks on the following components.
  - a. Front and rear sections of the rear driveshaft. Each section (front and rear) will have a separate yellow alignment mark.
  - b. Transfer Case driveshaft flange.
  - c. RDU driveshaft flange.

**NOTE: The alignment marks on both sections of the driveshaft may not align with each other which is normal. The alignment marks on each section of the driveshaft must align to their respective component (rear section to the RDU, and front section to the Transfer Case)**

This document does not authorize warranty repairs. This communication documents a record of past experiences. STAR Online does not provide any conclusions about what is wrong with the vehicle. Rather, it captures all previous cases known that appear to be similar or related to the vehicle symptom / condition. You are the expert, and you are responsible for deciding on the appropriate course of action.

**Contact STAR Center, or your Technical Assistance Center Via TechConnect, eCONTACT or Service Library entry if no solution is found.**



## STAR ONLINE PUBLICATION



3. Verify that the yellow alignment mark on the rear section of the driveshaft aligns with the RDU driveshaft flange. Please see (Figure 1). Were the alignment marks properly aligned?

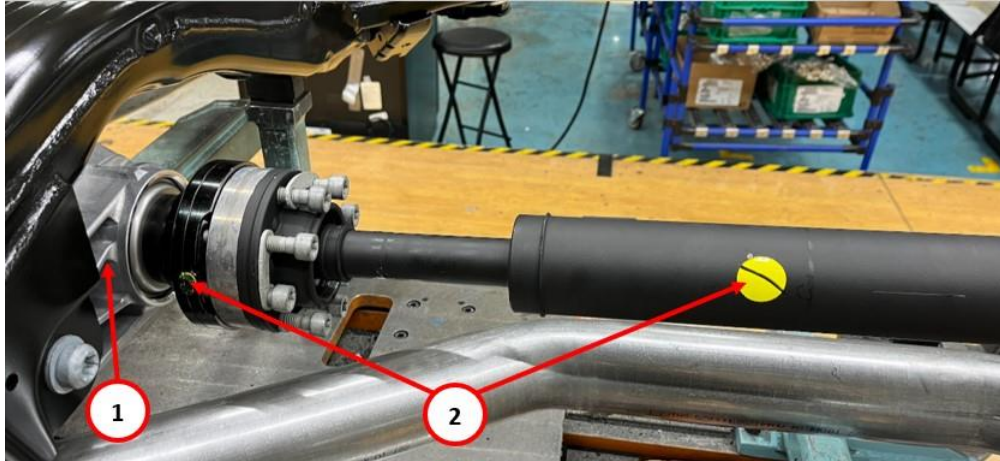

1. RDU
2. Alignment Marks

Figure1

- a. Yes>>> Go to [step 4](#).
  - b. No>>> Remove the driveshaft to RDU flange bolts in accordance with published service procedures in Service Library and align the marks before reinstalling. Proceed to [step 4](#).
4. Verify that the yellow alignment mark on the front section of the driveshaft align with the Transfer Case driveshaft flange. Please see (Figure 2). Were the alignment marks properly aligned?

This document does not authorize warranty repairs. This communication documents a record of past experiences. STAR Online does not provide any conclusions about what is wrong with the vehicle. Rather, it captures all previous cases known that appear to be similar or related to the vehicle symptom / condition. You are the expert, and you are responsible for deciding on the appropriate course of action.

**Contact STAR Center, or your Technical Assistance Center Via TechConnect, eCONTACT or Service Library entry if no solution is found.**



## STAR ONLINE PUBLICATION

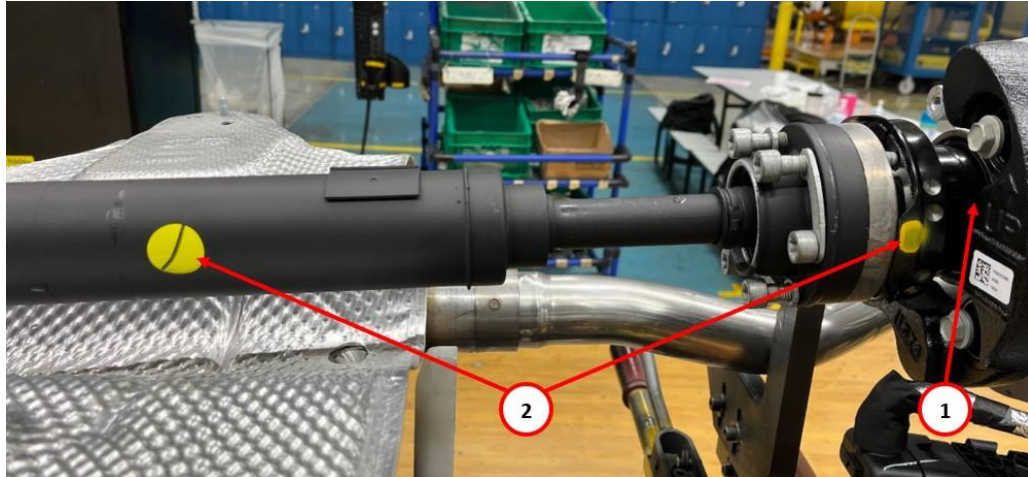

1. Transfer Case
2. Alignment Marks

Figure 2

- a. Yes>>> No further action is needed. Procedure is complete.
- b. No>>> Remove the driveshaft to Transfer Case flange bolts in accordance with published service procedures in Service Library and align the marks before reinstalling.

This document does not authorize warranty repairs. This communication documents a record of past experiences. STAR Online does not provide any conclusions about what is wrong with the vehicle. Rather, it captures all previous cases known that appear to be similar or related to the vehicle symptom / condition. You are the expert, and you are responsible for deciding on the appropriate course of action.

**Contact STAR Center, or your Technical Assistance Center Via TechConnect, eCONTACT or Service Library entry if no solution is found.**