

## Technical product information

<b>Topic</b>	Engine cooling system over cooling - One or a combination of DTC's may be evident P218100 - P1BB400
<b>Market area</b>	Bentley: worldwide (2WBE),China 796 VW Import Comp. Ltd (Vico), Beijing (6796)
<b>Brand</b>	Bentley
<b>Transaction No.</b>	2075140/1
<b>Level</b>	EH
<b>Status</b>	Approval
<b>Release date</b>	

### Event memory entries

Diagnostic address	Event memory entry	Fault type	Fault status
0001 - Engine electronics	P218100: Cooling System Performance		Intermittent
0001 - Engine electronics	P219100: System Too Lean at Higher Load; Bank 1		static
0001 - Engine electronics	P1BB400: Cylinder head temperature too low		Intermittent
0001 - Engine electronics	P1BB400: Cylinder head temperature too low		static
0001 - Engine electronics	P226300: Turbocharger/Supercharger Boost System Performance		Intermittent
0001 - Engine electronics	P06DA00: Engine Oil Pressure Control Circuit/Open		Intermittent
0001 - Engine electronics	P06DB00: Engine Oil Pressure Control Circuit Low		Intermittent

### New customer code

Object of complaint	Complaint type	Position
engine -> cooling, lubrication -> engine coolant temperature control	functionality -> faulty	
engine -> cooling, lubrication -> engine coolant temperature control	functionality -> too slow	
engine -> cooling, lubrication	functionality	
engine -> cooling system	functionality	

## Vehicle data

### Bentayga Series

#### Sales types

Type	MY	Brand	Designation	Engine code	Gearbox code	Final drive code
4V14D9	2018	E		*	*	*
4V14D9	2019	E		*	*	*
4V14D9	2020	E		*	*	*
4V14D9	2021	E		*	*	*
4V14D9	2022	E		*	*	*
4V14D9	2023	E		*	*	*
ZV14D9	2023	E		*	*	*

### New Continental GT/C and New Flying Spur

#### Sales types

Type	MY	Brand	Designation	Engine code	Gearbox code	Final drive code
3S32CB	2020	E		*	*	*
3S32CB	2021	E		*	*	*
3S32CB	2022	E		*	*	*
3S32CB	2023	E		*	*	*
3S34CB	2023	E		*	*	*
3S42CB	2020	E		*	*	*
3S42CB	2021	E		*	*	*
3S42CB	2022	E		*	*	*
3S42CB	2023	E		*	*	*
3S44CB	2023	E		*	*	*
ZG22CB	2021	E		*	*	*
ZG22CB	2022	E		*	*	*
ZG22CB	2023	E		*	*	*
ZG24CB	2023	E		*	*	*

---

## Documents

Document name
master.xml

---

## Customer statement / workshop findings

- DTC P218100 - Cooling System Performance and / or DTC P1BB400 Cylinder head temperature too low is stored in the Engine Control Module (ECM)
- Emission Control Lamp illuminated on the Driver Instrument Panel (Figure 1)



Figure 1

- The vehicle "warm up" time is longer when compared to comparison vehicles of the same specification (model / engine)

## Technical background

It is possible for the engine coolant thermostat to corrode over time, this corrosion is due to an adverse reaction of the thermostat material with the engine coolant

The corrosion and subsequent build-up of debris prevents the correct operation of the thermostat when closing, resulting in over cooling. The ECM triggers a DTC when the target engine temperature is outside of the specified parameter

In the event that the described symptoms are evident the operative should conduct the instructions within the Measure section

## Production change

-

## Measure

1) Replace the engine coolant thermostat (Figure 2) - Refer to 19 - Engine cooling - Coolant regulator (Thermostat insert) (V8 biturbo) - To remove and fit



**TIP:** Within the quoted Rep.Gr procedures there are single use items which must be replaced and not reused. Ensure that new replacements are available prior to starting this procedure



**IMPORTANT:** Ensure all procedures within the Repair manual are followed including full wheel alignment and calibrations

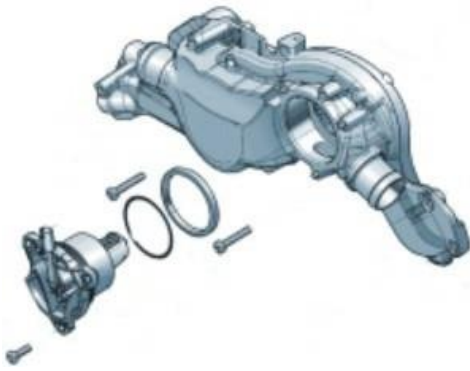

Figure 2

2) On completion conduct a road test to confirm the issue is resolved

### **Warranty accounting instructions**

Warranty type 110 or 910

Damage service number 19 58

Damage code 00 10

### **Bentayga - Up to and including 20 M/Y**

#### **Time to replace the Coolant regulator (Thermostat)**

Labour operation code 19 58 19 70

Time 120 TU

#### **Time to position the front end module into service position**

Labour operation code 50 38 09 20

Time 550 TU's

### **Bentayga - 21 M/Y onwards**

#### **Time to replace the Coolant regulator (Thermostat)**

Labour operation code 19 58 19 70

Time 120 TU

#### **Time to position the front end module into service position**

Labour operation code 50 38 09 20

Time 630 TU's

### **Road test**

Labour operation code 01 21 00 00

Time 50 TU



**IMPORTANT:** Ensure all procedures within the Repair manual are followed including full wheel alignment and calibrations

#### **Time to replace the Coolant regulator (Thermostat) depending on model**

### **New Continental GT/C**

Labour operation code 19 58 19 70

Time - 130 TU's

### **New Flying Spur**

Labour operation code 19 58 19 70

Time - 130 TU's

### **Road test**

Labour operation code 01 21 00 00

Time 50 TU

### **Parts information**

Refer to the electronic parts catalogue (ETKA).