

ATTENTION:
 GENERAL MANAGER
 PARTS MANAGER
 CLAIMS PERSONNEL
 SERVICE MANAGER

IMPORTANT - All Service Personnel Should Read and Initial in the boxes provided, right.

© 2024 Subaru of America, Inc. All rights reserved.



QUALITY DRIVEN® SERVICE

SERVICE INFORMATION BULLETIN

APPLICABILITY: All FA and FB Engines

NUMBER: 02-192-24

DATE: 09/26/24

SUBJECT: Engine Oil Leak Diagnostic Procedures

INTRODUCTION:

This Service Information Bulletin announces the diagnostic procedures to be followed when diagnosing engine oil leakage on FA and FB type engines. The procedures outlined in this bulletin were designed to enhance accuracy and help prevent any unnecessary service procedures performed.

SERVICE PROCEDURE / INFORMATION:

The initial step required is to narrow down the possible leaking points according to the production improvement history that can be traced by VIN. The next step is to inspect the status of oil leakage and/or adhesion to identify the area to be repaired.

Narrowing down the possible leaking points (target of repair parts). Based on research conducted in the field, Formed In Place Gasket (FIPG/Three Bond) application process in the production line has been enhanced. When diagnosing a vehicle with alleged oil leakage from the engine, start with finding the place of leakage by excluding the enhanced points. If FIPG application is confirmed to be required, refer to the **APPENDIX A** section of this bulletin for General Guidelines of FIPG Application.

HOW TO USE THE VIN BREAK TABLES:

EXAMPLE:

- A FORESTER with VIN “JF2SK****M*548715” is currently being inspected.
- Compare this VIN to those described in the row “FORESTER <SK-type>” from the right-most column until you find the VIN break that is lower than the above vehicle (in this example, it is higher than MH548714 mentioned in the second column from the left.)
- It is at the bottom of the same row that shows the target (Target B in this case) of what areas to be inspected. If the searched VIN is lower than any VIN break mentioned in the applicable row, look at the bottom of the column described as “VINs below the right listed” and find the target area.

CAUTION: VEHICLE SERVICING PERFORMED BY UNTRAINED PERSONS COULD RESULT IN SERIOUS INJURY TO THOSE PERSONS OR TO OTHERS.

Subaru Service Bulletins are intended for use by professional technicians ONLY. They are written to inform those technicians of conditions that may occur in some vehicles, or to provide information that could assist in the proper servicing of the vehicle. Properly trained technicians have the equipment, tools, safety instructions, and know-how to do the job correctly and safely. If a condition is described, DO NOT assume that this Service Bulletin applies to your vehicle, or that your vehicle will have that condition.

Subaru of America, Inc. is ISO 14001 Compliant

ISO 14001 is the international standard for excellence in Environmental Management Systems. Please recycle or dispose of automotive products in a manner that is friendly to our environment and in accordance with all local, state and federal laws and regulations.

Continued...

VIN BREAK TABLES:

All models except for IMPREZA and GU-Type CROSSTREK					
MODEL	VIN Breaks				
FORESTER <SK-type>	VINs below the right listed	JF2SKAFC0 MH548714 -	-	JF2SKADC4 PH468548 -	JF2SKECC3 PH526304 -
WRX <VA/VB-type>	VINs below the right listed	JF1VA1C67 M9808118 -	-	JF1VBAF64 N9021010 -	JF1VBAN63 P8809139 -
BRZ <ZN/ZD-type>	-	Lower than the right	-	JF1ZDBB1X P9701301 -	JF1ZDBE17 P9705270 -
CROSS TREK <GT-type>	VINs below the right listed	JF2GTAEC6 NH273291	-	JF2GTHRC4 NH273292 -	JF2GTHMC1 PH258078 -
LEGACY <BW-type>	VINs below the right listed	4S3BWGP67 M3019868 -	4S3BWGP66 N3013772 -	4S3BWAD65 P3016098 -	4S3BWGG63 P3017099 -
OUTBACK <BT-type>	VINs below the right listed	4S4BTGLD6 M3216622 -	4S4BTADC7 N3190892 -	4S4BTHTD3 P3199630 -	4S4BTAAC5 P3211391 -
ASCENT <WM-type>	VINs below the right listed	4S4WMAAD3 M3449565 -	4S4WMAMD8 N3416185 -	4S4WMAKD4 P3424998 -	4S4WMAKD2 P3435661 -
	↓	↓	↓	↓	↓
Target	A	B	C	D	E
Areas with factory C/M	None	Chain Cover-FIPG (1,3)	Oil Pan-FIPG (5)	Oil Pan UPR-FIPG (6)	Cam Carrier-FIPG (2,4)
Inspection Areas	All (1 to 7)	2,4,5,6,7	2,4,6,7	2,4,7	2*,4*,7

NOTE*: See detailed information for AREA 2 and AREA 4.

IMPREZA GK and GT-Type Models					
MODEL	VIN Breaks				
IMPREZA <GK-type>	VINs below the right listed	4S3GKAB63 M3606798 -	4S3GKAV66 N3606484 -	4S3GKAD61 P3603206 -	4S3GKAV69 P3605686 -
IMPREZA <GT-type>	VINs below the right listed	4S3GTAV65 M3715854 -	4S3GTAM66 N3717180 -	4S3GTAV65 P3710044 -	4S3GTAM60 P3718442 -
	↓	↓	↓	↓	↓
Target	A	B	C	D	E
Areas with factory C/M	None	Chain Cover-FIPG (1,3)	Oil Pan-FIPG (5)	Cam Carrier-FIPG (2,4)	Oil Pan UPR-FIPG (6)
Inspection Areas	All (1 to 7)	2,4,5,6,7	2,4,6,7	2*,4*,6,7	2*,4*,7

NOTE*: See detailed information for AREA 2 and AREA 4.

Continued...

GU-Type (Japan Production)					
MODEL	VIN Breaks				
CROSS TREK IMPREZA <GU-type @ SBR>	-	-	-	JF1GUABCX R8255016 -	-
	↓	↓	↓	↓	↓
Target	A	B	C	D	E
Areas with factory C/M	None	Chain Cover-FIPG (1,3)	Oil Pan-FIPG (5)	Cam Carrier-FIPG (2,4)	Oil Pan UPR-FIPG (6)
Inspection Areas	-	-	-	2*,4*,7	-

NOTE*: See detailed information for AREA 2 and AREA 4.

GU-TYPE (SIA Production)					
MODEL	VIN (Old → New)				
CROSS TREK IMPREZA <GU-type @ SIA>	-	-	-	-	4S4GUHN62 R3700012 -
	↓	↓	↓	↓	
Target	A	B	C	D	E
Areas with factory C/M	None	Chain Cover-FIPG (1,3)	Oil Pan-FIPG (5)	Cam Carrier-FIPG (2,4)	Oil Pan UPR-FIPG (6)
Inspection Areas	-	-	-	-	2*,4*,7

NOTE*: See detailed information for AREA 2 and AREA 4.

AREA SECTION LOCATION OVERVIEW:

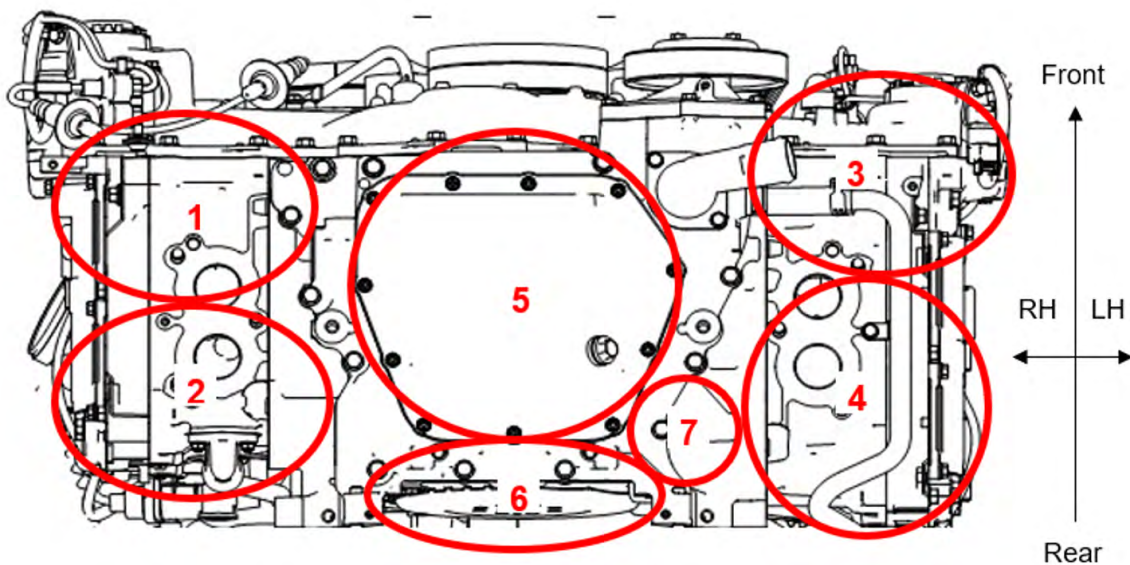

Bottom View of the Engine

Continued...

AREA 1: Right Front Side

Identify which of the following items has adhesion of engine oil from 1, 2 or 3. Depending on the place of oil adhesion confirmed, reseal the mating surfaces as instructed below.

1. **Timing Chain Cover – Cylinder Head – Cylinder Block Seal Surfaces:** Reseal the mating surfaces between the Timing Chain Cover, Cylinder Head and the Cylinder Block.

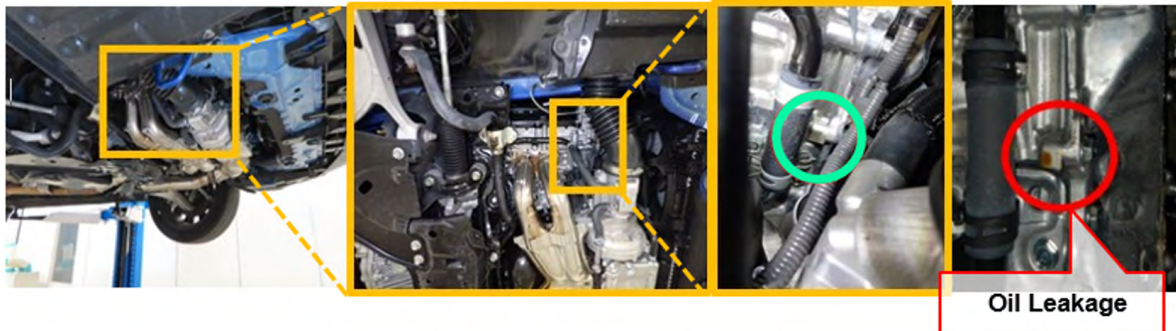

2. **Timing Chain Cover – Cam Carrier – Cylinder Head Seal Surfaces:** Reseal the mating surfaces between the Timing Chain cover, Cam Carrier, and the Cylinder Head.

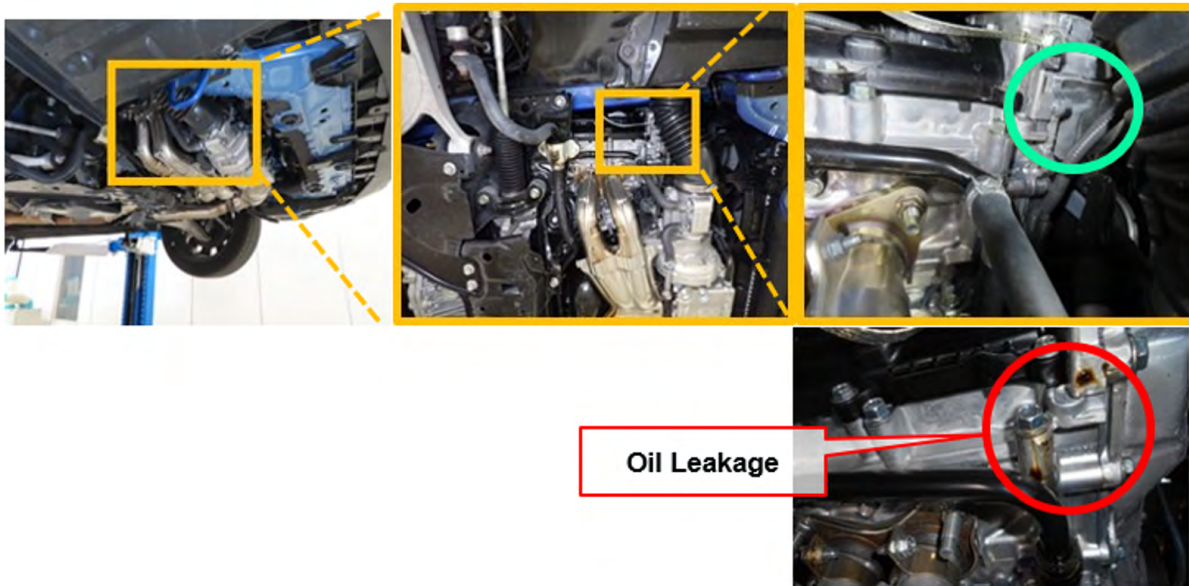

3. **Timing Chain Cover – Cam Cap – Cam Carrier Seal Surfaces:** Reseal the mating surfaces between the Timing Chain Cover, Cam Cap, and the Cam Carrier.

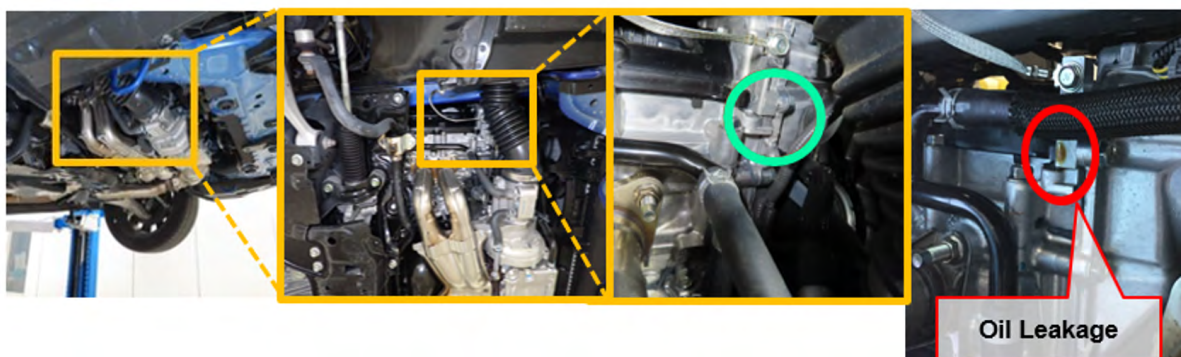

Continued...

AREA 2: Right Rear Side

Identify which of the following items has adhesion of engine oil from 1, 2 or 3. Depending on the place of oil adhesion confirmed, reseal the mating surfaces as instructed below. If the target inspection area was indicated with a (*) in the VIN Break Table, proceed to 3 because 1 and 2 will not apply.

- 1. Cam Cap – Cam Carrier Sealing Surfaces:** Reseal the mating surfaces between the Cam Cap and the Cam Carrier.

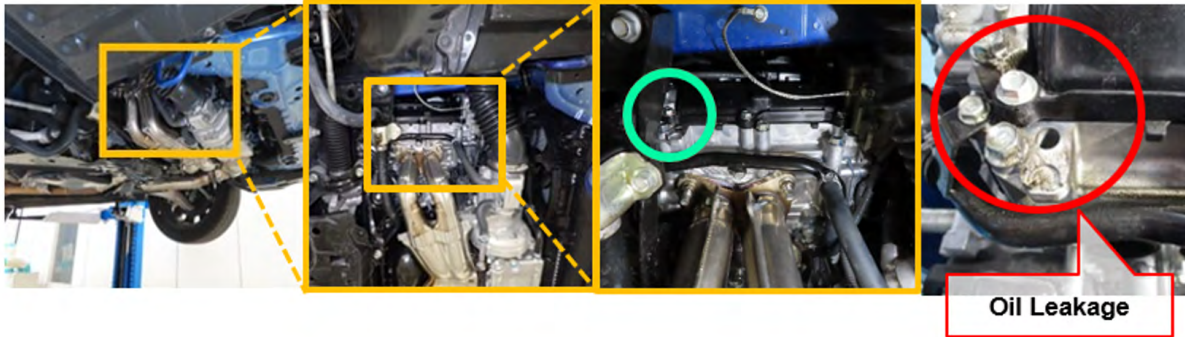

- 2. Cam Carrier – Cylinder Head:** Reseal the mating surfaces between the Cam Carrier and the Cylinder Head.



- 3. Vacuum Pump or Cylinder Head Plate (BRZ ONLY):** Reseal the mating surfaces between the Vacuum Pump, Cylinder Head Plate, and the Right Rear Intake Cam Cap.

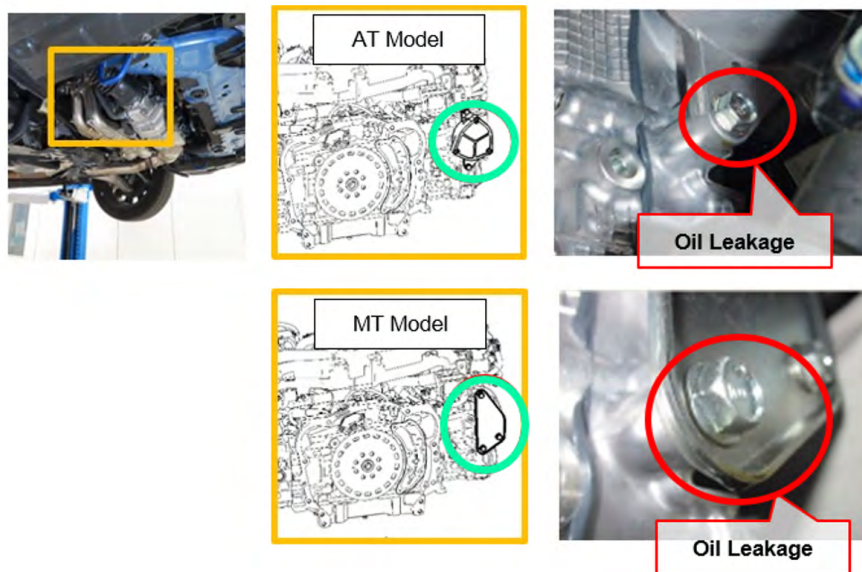

Continued...

AREA 3: Left Front Side

Identify which of the following items has adhesion of engine oil from 1, 2 or 3. Depending on the place of oil adhesion confirmed, reseal the mating surfaces as instructed below.

- 1. Chain Cover – Cylinder Head _ Cylinder Block Seal Surfaces:** Reseal the mating surfaces between the Chain Cover, Cylinder Head, and the Cylinder Block.

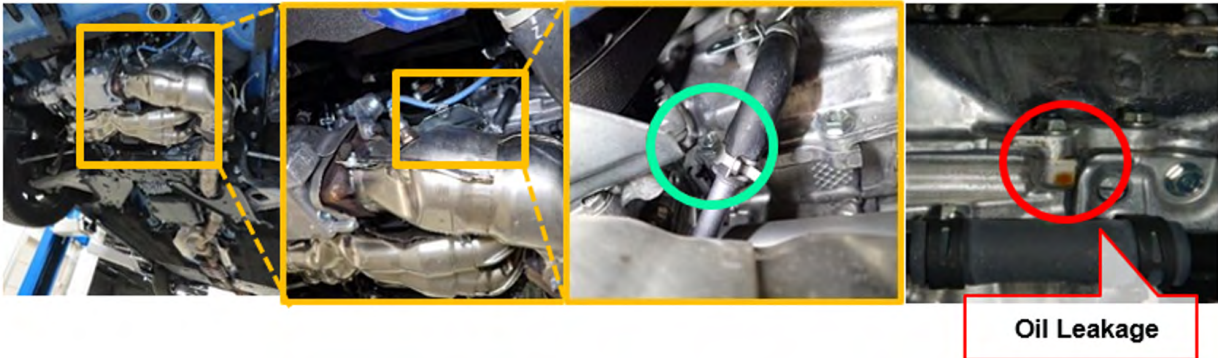

- 2. Chain Cover – Cam Carrier – Cylinder Head Seal Surfaces:** Reseal the mating surfaces between the Chain Cover, Cam Carrier, and the Cylinder Head.

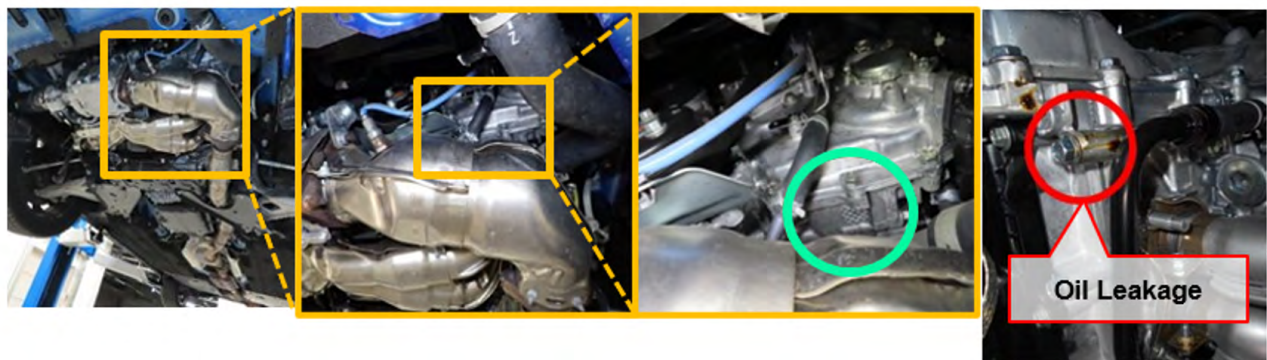

- 3. Chain Cover – Cam Cap – Cam Carrier Seal Surfaces:** Reseal the mating surfaces between the Chain Cover, Cam Cap, and the Cam Carrier.

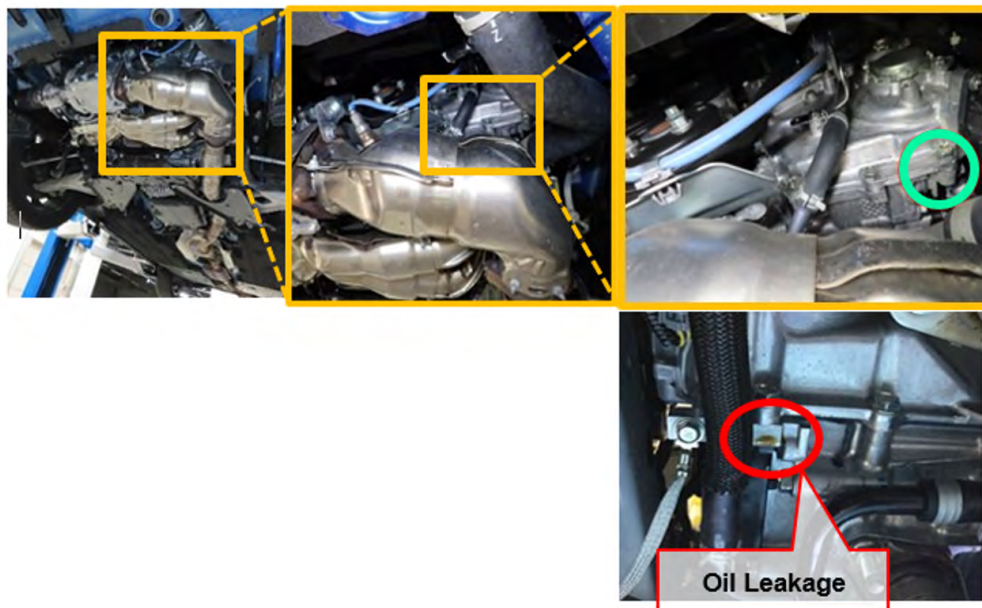

Continued...

AREA 4: Left Rear Side

Identify which of the following items has adhesion of engine oil from 1, 2 or 3. Depending on the place of oil adhesion confirmed, reseal the mating surfaces as instructed below. If the target inspection area was indicated with a (*) in the VIN Break Table, proceed to 3 because 1 and 2 will not apply.

1. **Cam Cap – Cam Carrier Sealing Surface:** Reseal the Cam Cap to the Cam Carrier.



2. **Cam Carrier – Cylinder Head Sealing Surface:** Reseal the Cam Carrier to the Cylinder Head.

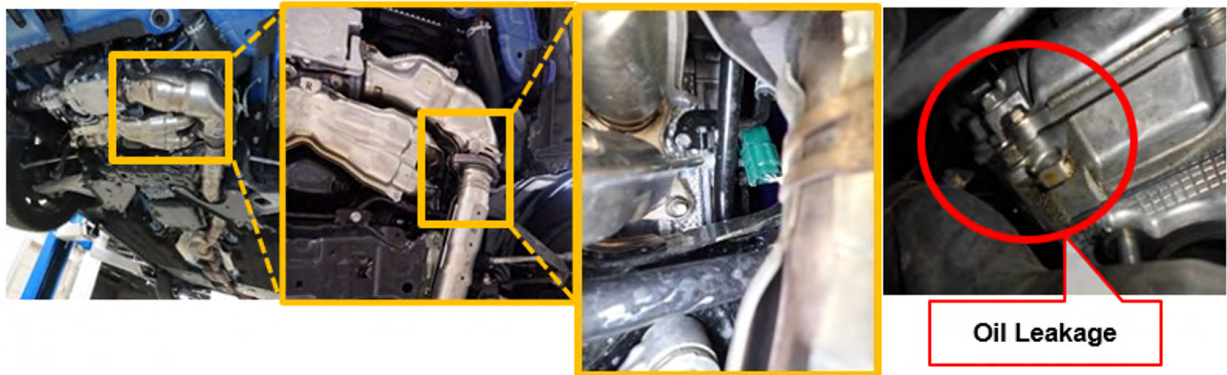

3. **Front M6 Bolt:** Remove the indicated bolt and reinstall with Three Bond applied to the bolt head mating surface.

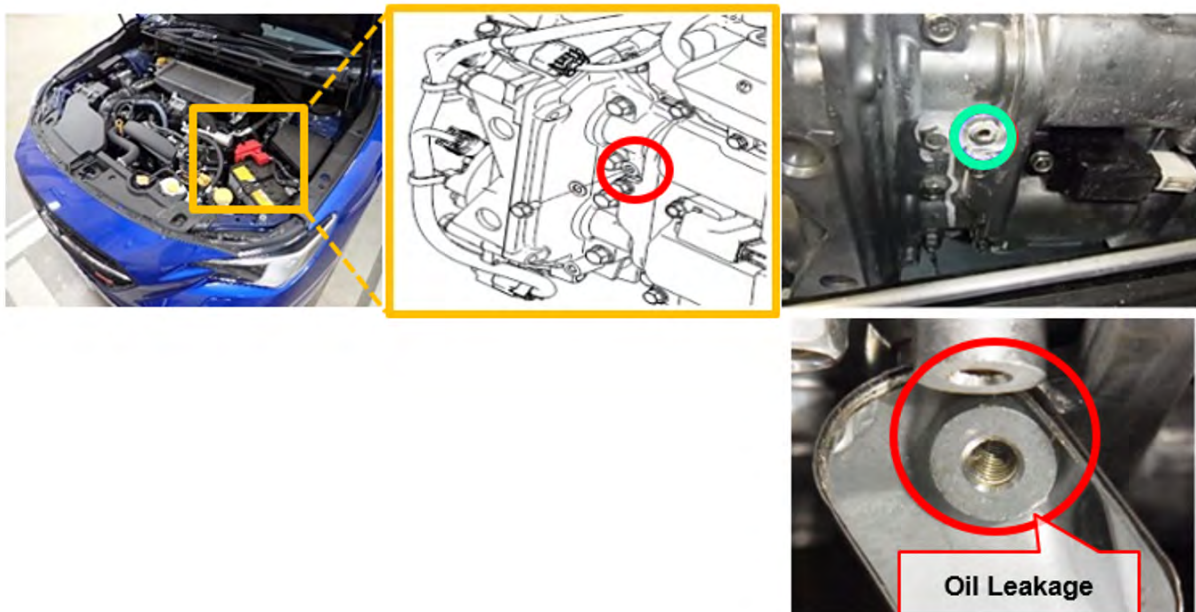

Continued...

AREA 5: Oil Pan / Upper Oil Pan

1. **Oil Pan / Upper Oil Pan:** Reseal the mating surfaces between the Oil Pan and the Upper Oil Pan.

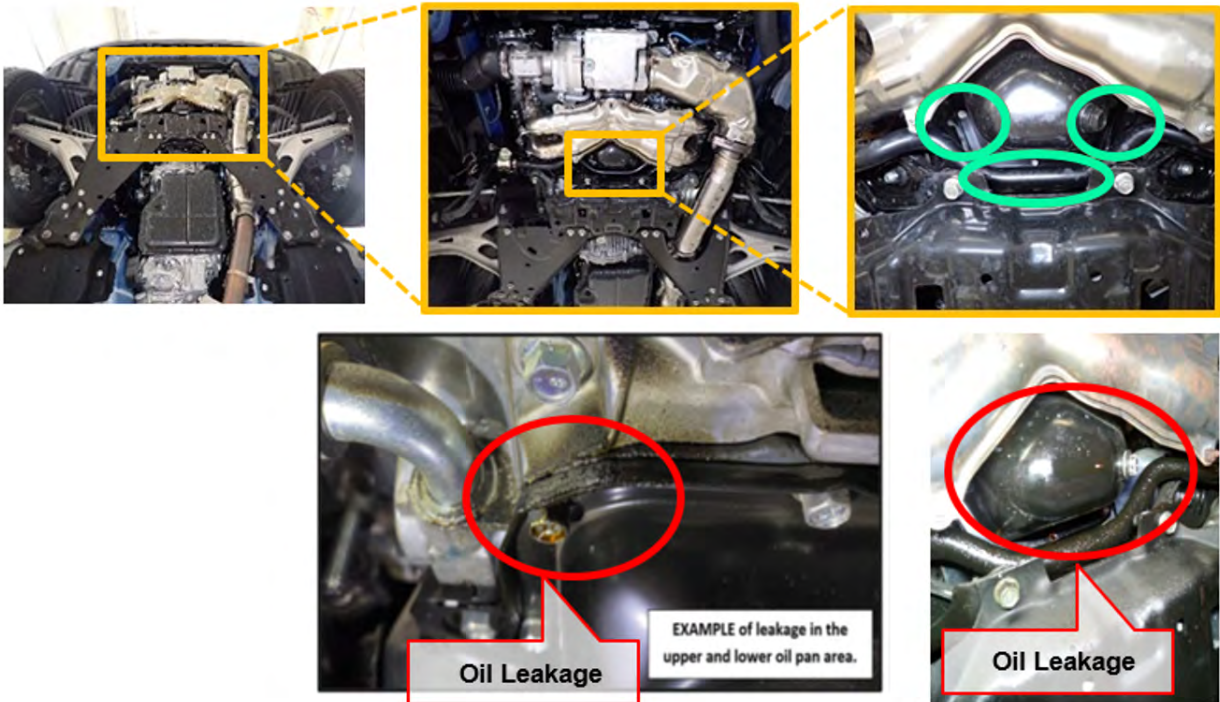

AREA 6: Engine / Transmission Mounting Area

1. **Engine / Transmission Mounting Area:** Reseal the mating surfaces between the Upper Oil Pan and the Engine Block.



Continued...

AREA 7: Oil Level Switch Area

1. **Oil Level Switch Area:** Inspect for oil leakage in the following areas.

- **Oil Pan**
- **Upper Oil Pan**
- **Lower Section of the Engine Block**
- **Lower Section of the Cylinder Head**
- **Engine / Transmission Mounting Surfaces**

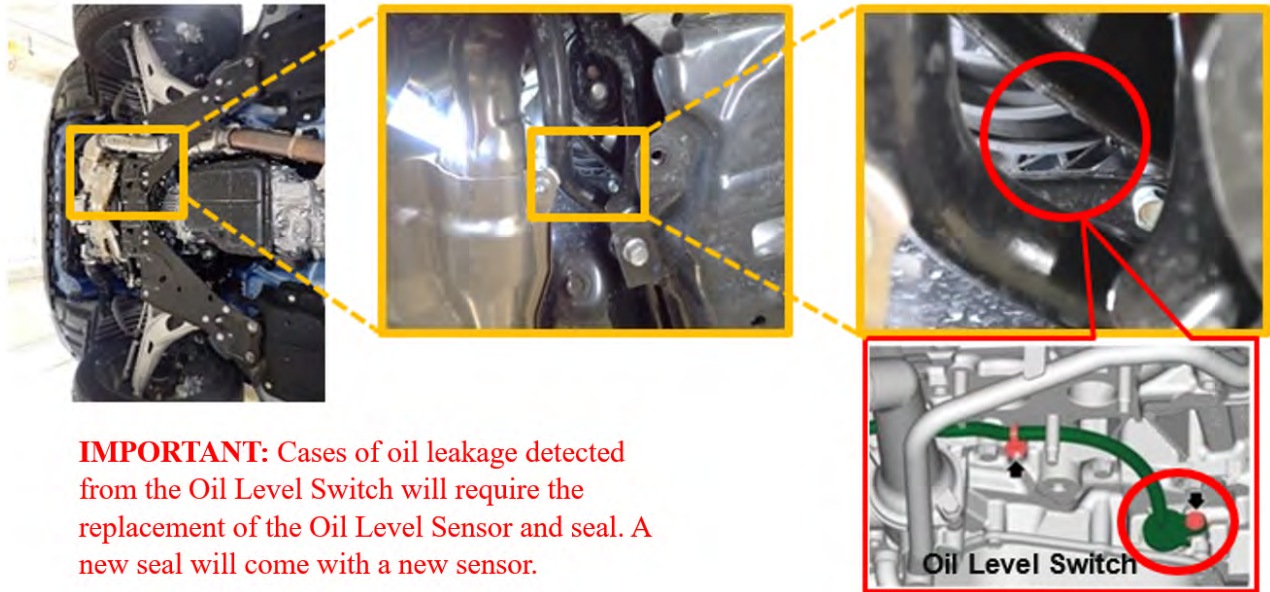

SPECIAL TOOLS:

When removing and installing the timing chain cover it is important to using the Subaru special tools J-51972 & J53038. Using these tools will help reduce the possibility of damaging the chain cover during removal while also ensuring better Three Bond sealing during installation.



Detailed on the usagae of these tools is outlined in TSB [14-26-20](#)

Continued...

These essential tools have been shipped to all Subaru retailers. Additional quantities can be ordered through the Service Tools & Equipment page on Subarunet: [Subarunet > Service Operations & Technical > Service Tools & Equipment > Subaru Essential & Special Tools](#) or go directly to: <https://www.subaruretailersolutions.com/>

ADDITIONAL MATERIALS:

- **Spotcheck SKD-S2** can be used to aid in the oil leakage inspection process. SKD-S2 is a fast drying solvent that provides a white opaque coating when applied. This gives a contrasting background for the inspection area.



- Use of aerosol Subaru Silicone Gasket Remover (p.n. **SOA868V9175**) along with WHITE plastic razor blades and / or a sharpened plastic trim removal stick to use as a non-marring scraper make sealer removal easier. Applying the Gasket Remover spray and allowing it to “soak” also helps. NEVER use steel razor blades or abrasive discs as they can easily damage the machined aluminum sealing surfaces.



WARRANTY / CLAIM INFORMATION:

Refer to the Labor Time Guide for model, repair, and claim specific information.

IMPORTANT REMINDERS:

- SOA strongly discourages the printing and/or local storage of service information as previously released information and electronic publications may be updated at any time.
- Always check for any open recalls or campaigns anytime a vehicle is in for servicing.
- Always refer to STIS for the latest service information before performing any repairs.

Continued...

APPENDIX A

General Guidelines for FIPG Application

FIPG*1 Application Procedure



SUBARU

Confidence in Motion



Note*1) FIPG = Formed In Place Gasket (Liquid Gasket)



SUBARU

Confidence in Motion

Introduction

This document shows the application procedure when resealing the engine with FIPG. Please refer to this material to accomplish repair work in case of oil leakage on FB/FA engine.

【CONTENTS】

1.Sealing mechanism of FIPG	P.3
2.Quality Compliance Items	P.4
3.Application conditions and precautions for each part	
3-1.Points to note when applying FIPG (How to remove extra liquid gasket after part assembly)	P.5 - 6
3-2.Block, Separator cover, Head gasket	P.7 - 14
3-3.Cam Carriers, Cam Caps	P.10 - 13
3-4.Vacuum Pump, Plate, High Pressure Fuel Pump Case	P.14 -16
3-5.Rocker Cover, Oil Pan UPR, Oil Pan	P.17 - 20
3-6.Chain cover	P.21 - 22

FIPG sealing mechanism

FIPG is extruded from the cartridge, and when it comes into contact with moisture in the air. The chemical reaction of FIPG with moisture in the air after it is extruded from the cartridge accelerates its adhesion to the sealing surface and its rubberization, resulting in sealing performance. Therefore, if there are any obstacles during the chemical reaction, it will not be possible to achieve sufficient sealing performance.

【Major inhibitors to sealing performance】

- ①: Dirt on the seal surface**
- ②: Insufficient FIPG filling volume**
- ③: Long leaving time between application and component assembly**
- ④: Insufficient time required for curing**

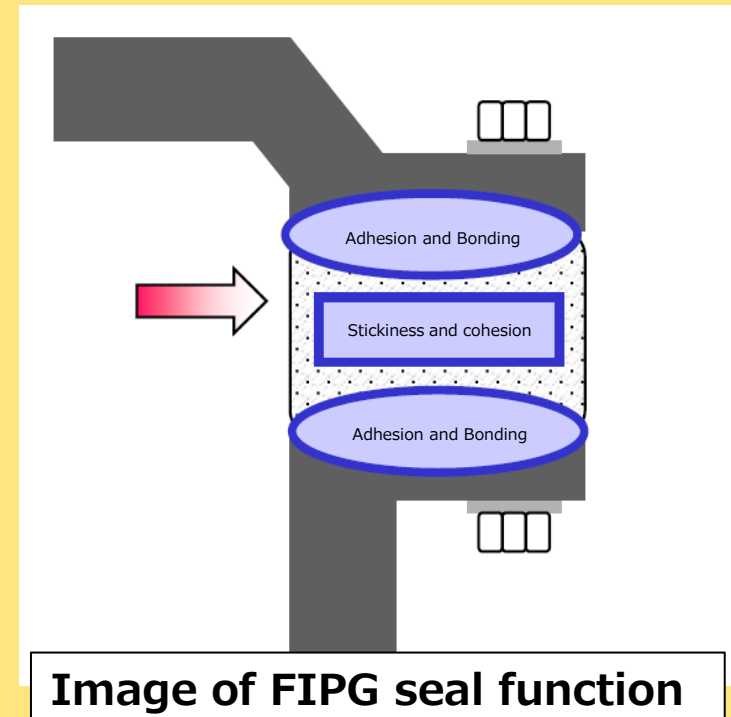

Quality Compliance Items

● **Compliance with the FIPG application process** ●
Please observe the following to ensure that the sealing performance is fully demonstrated.

- ①: **Clean and degrease the seal surface thoroughly.**
- ②: **Apply FIPG in the proper position and amount.**
- ③: **Install the parts within 5 minutes after applying FIPG.**
- ④: **After assembly, allow sufficient time for curing before refilling engine oil.**

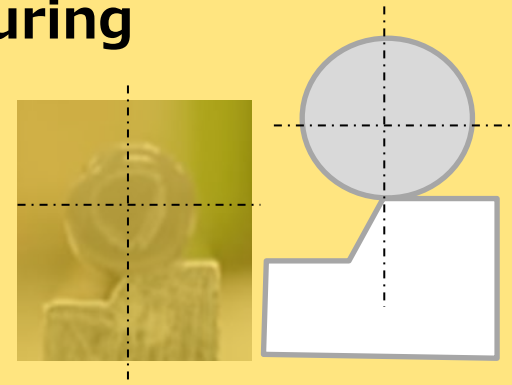

※ **Be aware that residual oil inside the engine will drip even after cleaning.**

※ **Approximate curing time after assembly @20°C: FA/FB (2.2H or more)**

Note: Required curing time varies depending on the amount of application.

Precautions when applying FIPG (FA/FB) (How to remove extra liquid gasket after part assembly)

After assembling the surrounding parts, extra FIPG will stick out from the sealing surfaces of the assembled parts (Chain cover, etc.). Before the FIPG gets hardened, completely remove the extra FIPG with scraper, etc. to the directions indicated by arrows in the chart below.

Chain cover part

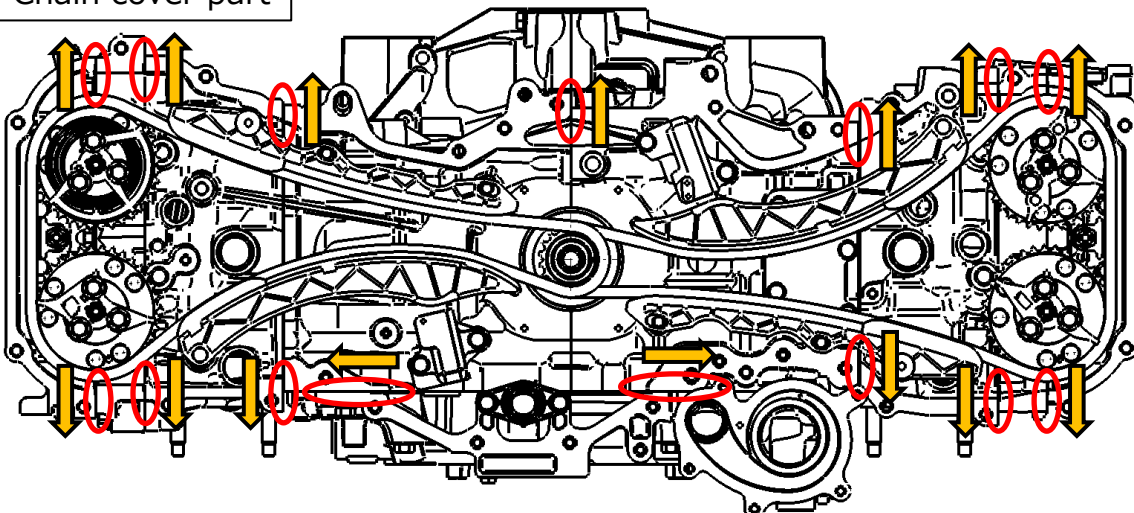

Vacuum pump section
(RH rear side)

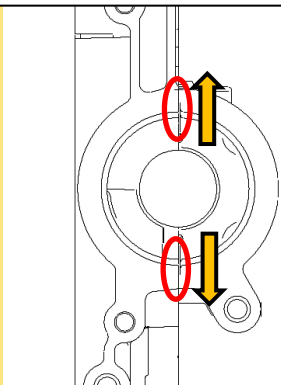

High-pressure fuel pump case section
(LH upper side)

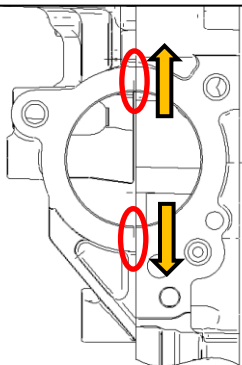

Before removal

After removal

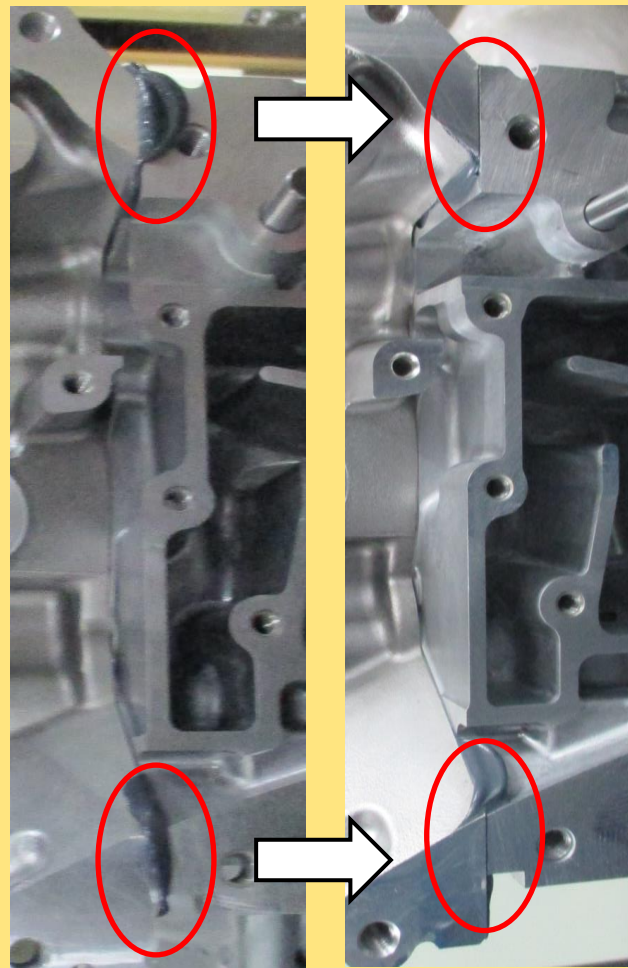



SUBARU

Confidence in Motion

Engine Block mating surface (FA/FB)

If extra FIPG sticks out from the sealing surfaces of the Chain Cover after installation, remove the extra FIPG completely with scraper, etc. to the directions indicated by arrows in the chart below before hardening.

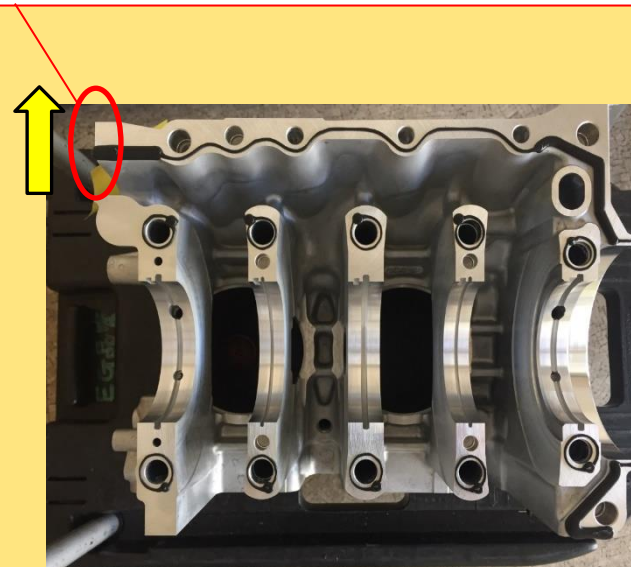
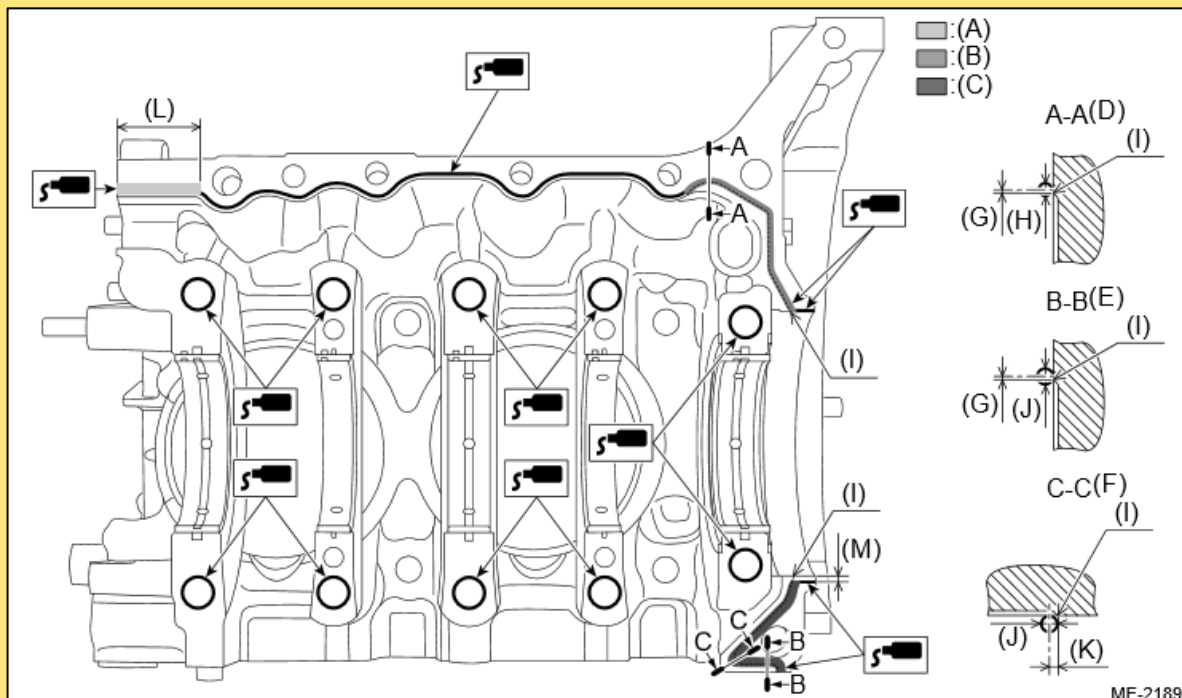

- (A):Range A (B):Range B (C):Range C
- (D):FIPG application position on mating surface in range B
- (E):FIPG application position of the mating surface part (other than the tip) of range C
- (F):FIPG application position of the mating surface part (tip) of range C
- (G):Within 1mm (H): $\Phi 3.2 \pm 0.5\text{mm}$ (I):Chamfer edge
- (J): $\Phi 4 \pm 0.5\text{mm}$ (K):2mm (L):36mm (M):2.5mm

Separator cover (FA/FB)

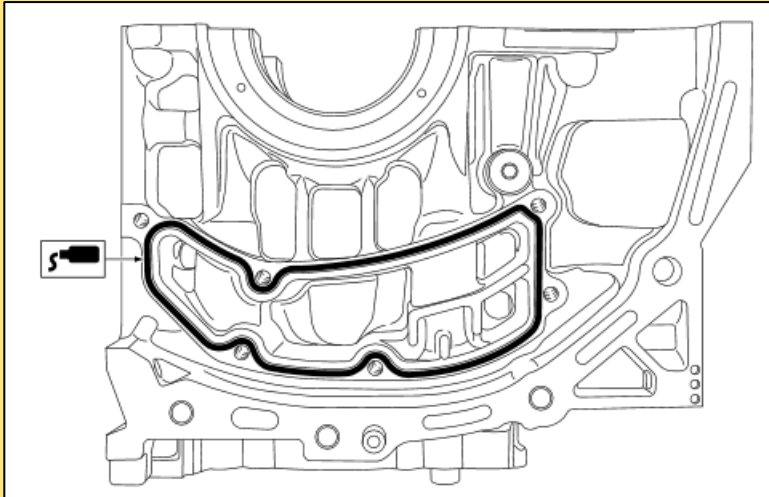

The photo shows the condition when FIPG is applied to the separator cover side.

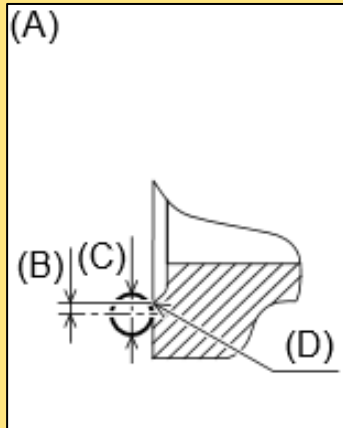

(A): FIPG application position
(B): Within 1mm
(C): $\Phi 4 \pm 1\text{mm}$
(D): Chamfer edge

Head gasket LH (FA/FB)

If extra FIPG sticks out on the sealing surfaces of the Cylinder Head after installation, remove the extra FIPG completely with scraper, etc. to the directions indicated by arrows in the chart below before hardening.

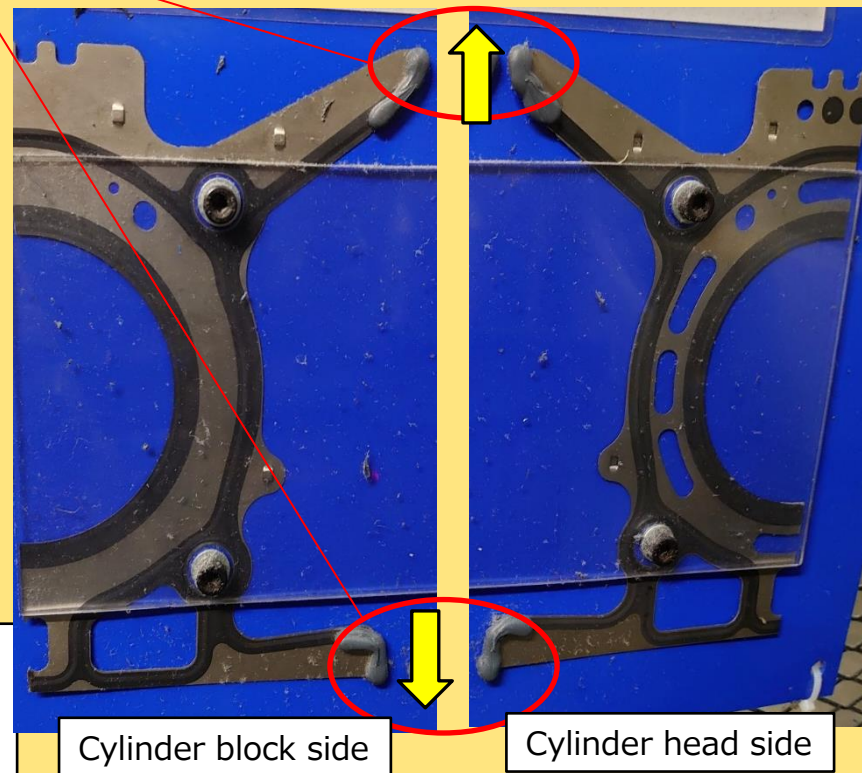
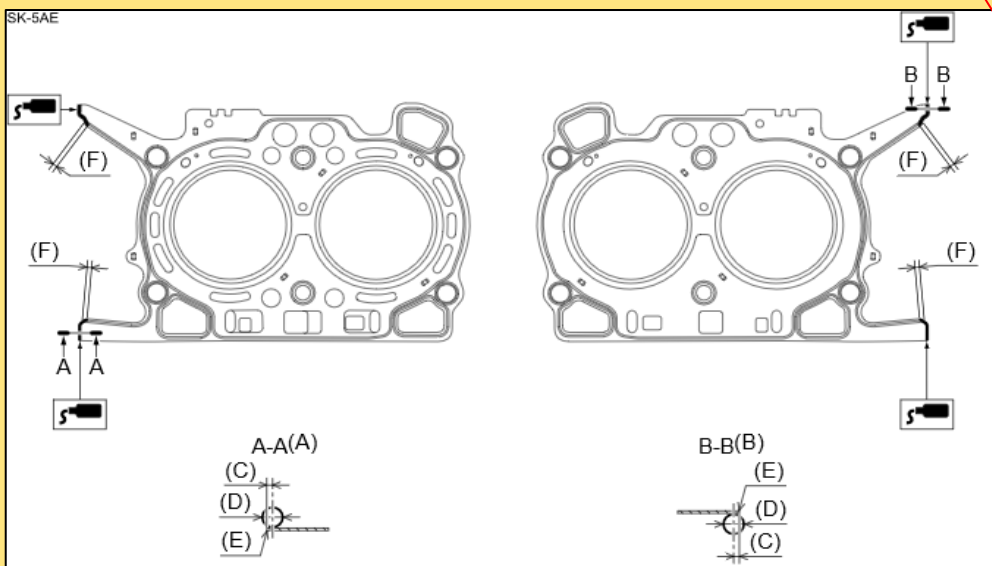

- (A): FIPG application position on Cylinder head side
- (B): FIPG application position on Cylinder block side
- (C): Within 1mm
- (D): $\Phi 3 \pm 1$ mm
- (E): Cylinder head gasket end
- (F): Overlap between bead end and FIPG 3 to 10mm

Head gasket RH (FA/FB)

If extra FIPG sticks out on the sealing surfaces of the Cylinder Head after installation, remove the extra FIPG completely with scraper, etc. to the directions indicated by arrows in the chart below before hardening.

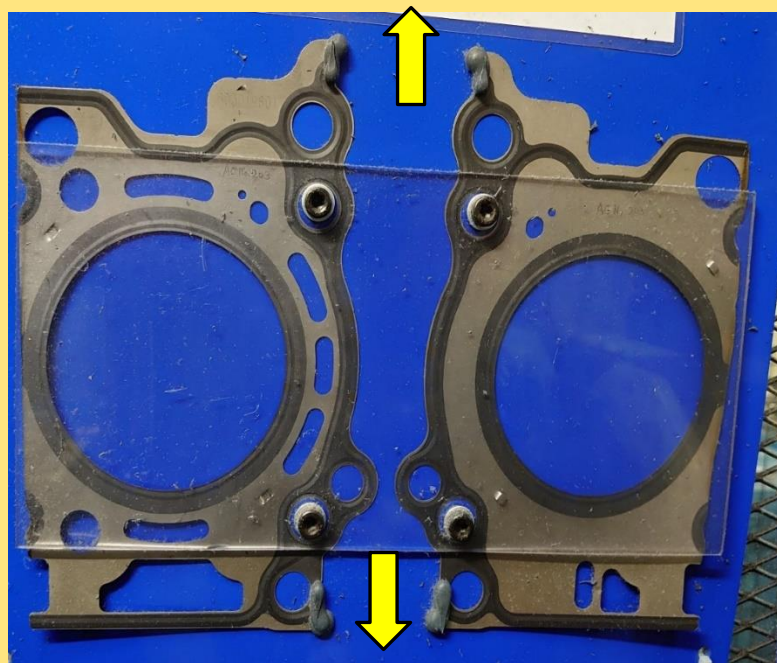
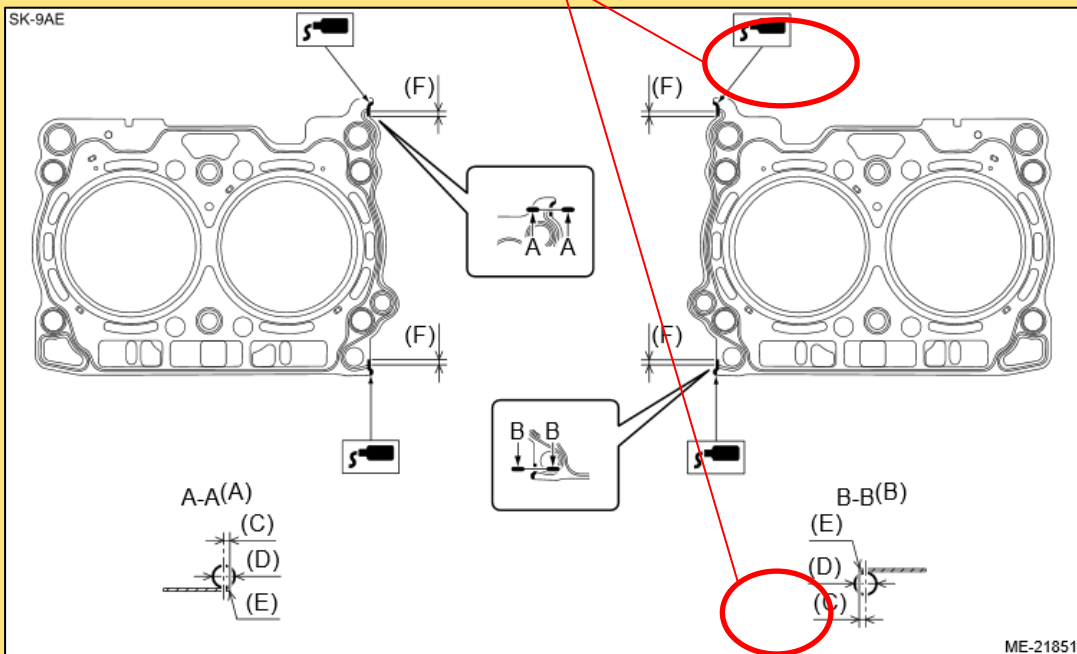

Cylinder head side

Cylinder block side

- (A): FIPG application position on Cylinder head side
- (B): FIPG application position on Cylinder block side
- (C): Within 1mm
- (D): $\Phi 3 \pm 1$ mm
- (E): Cylinder head gasket end
- (F): Overlap between bead end and FIPG 3 to 10mm

Cam Carrier RH (FA/FB)

If extra FIPG sticks out on the sealing surfaces of the Cam Carrier after installation, remove the extra FIPG completely with scraper, etc. to the directions indicated by arrows in the chart below before hardening.

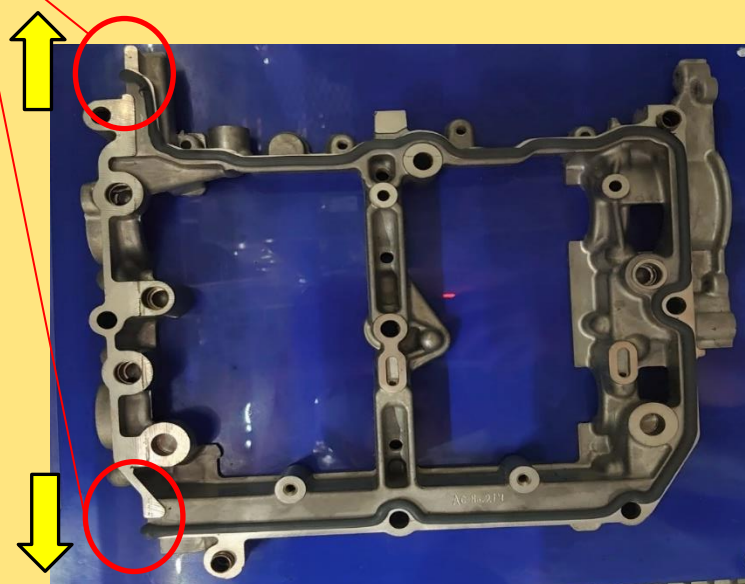
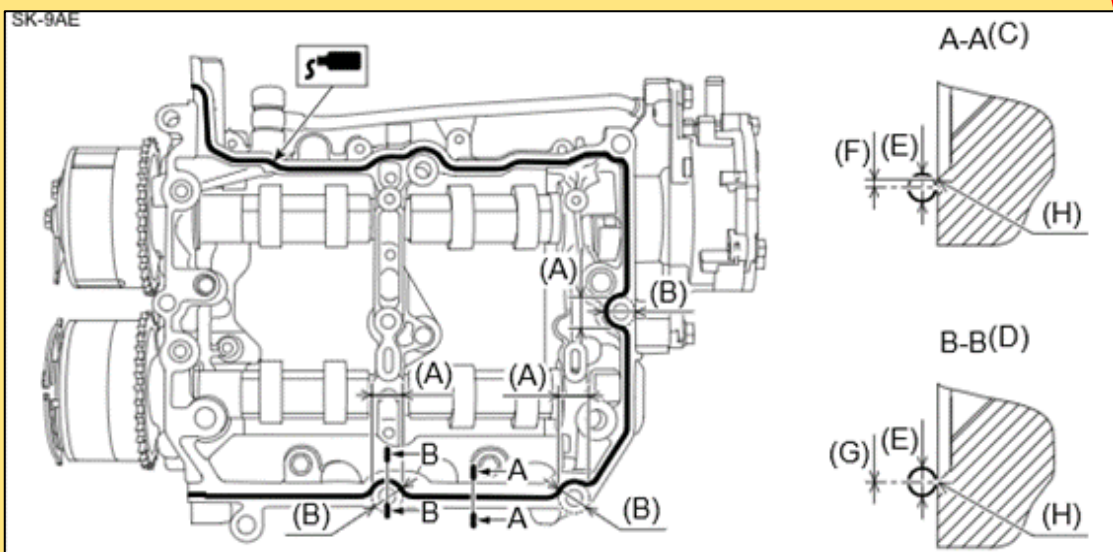

- (A):Range A (B): $\Phi 18\text{mm}$
- (C):FIPG application position of mating areas other than Range A
- (D):FIPG application position of mating areas in Range A
- (E): $\Phi 4\pm 0.5\text{mm}$ (F): $1\pm 1\text{mm}$ (G): $0\pm 0.5\text{mm}$ (H):Chamfer edge

Cam Carrier LH (FA/FB)

If extra FIPG sticks out on the sealing surfaces of the Cam Carrier after installation, remove the extra FIPG completely with scraper, etc. to the directions indicated by arrows in the chart below before hardening.

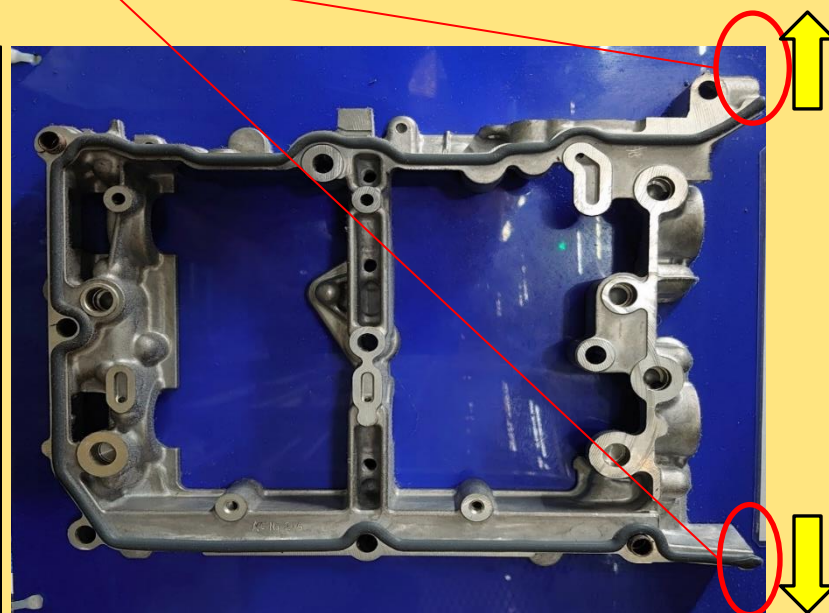
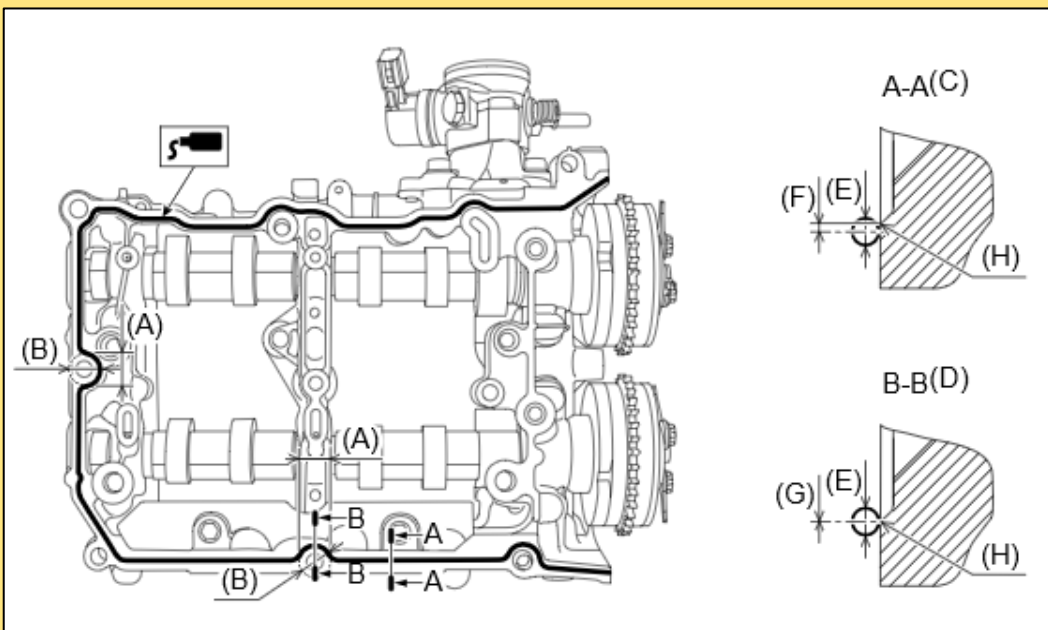

(A):Range A (B): $\Phi 18\text{mm}$

(C):FIPG application position of mating areas other than Range A

(D):FIPG application position of mating areas in Range A

(E): $\Phi 4 \pm 0.5\text{mm}$ (F): $1 \pm 1\text{mm}$ (G): $0 \pm 0.5\text{mm}$ (H):Chamfer edge

Camshaft Cap RH (FA/FB)

If extra FIPG sticks out on the sealing surfaces of the Camshaft Cap & Vacuum Pump after installation, completely remove the extra FIPG with scraper, etc. in the directions indicated with arrows in the chart below before curing.

Remove extra FIPG with scraper, etc. in the directions indicated by arrows to avoid interference with the Vacuum Pump.

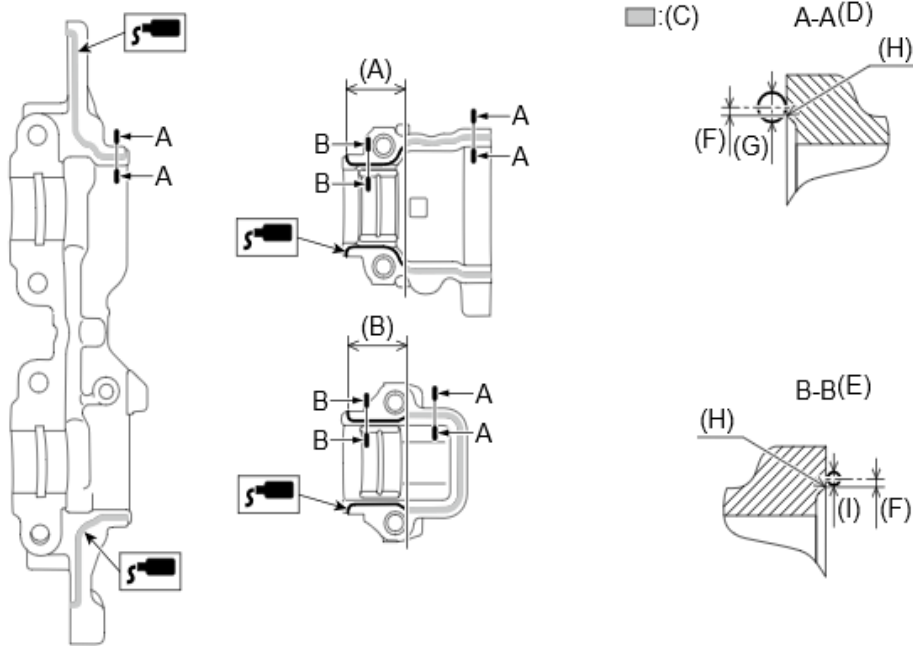

- (A):29mm (B):28.5mm (C):Range A
- (D):FIPG application position of mating area in Range A
- (E):FIPG application position of mating area other than Range A
- (F):1mm (G): $\Phi 3 \pm 0.5$ mm
- (H):Chamfer edge (I): $\Phi 2 \pm 0.5$ mm

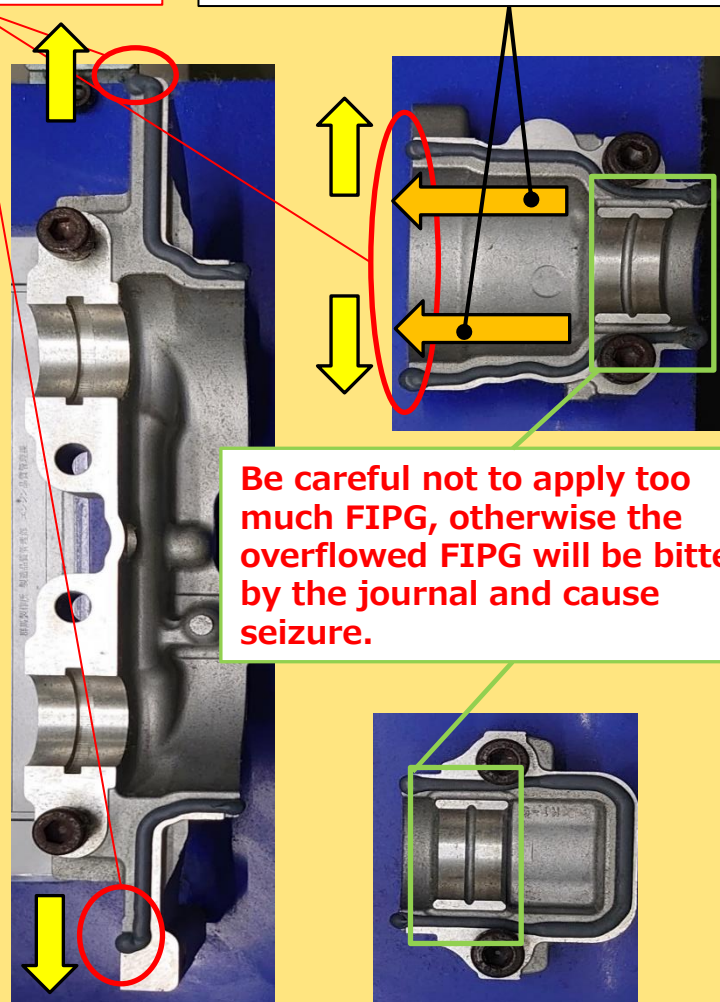

Be careful not to apply too much FIPG, otherwise the overflowed FIPG will be bitten by the journal and cause seizure.

Camshaft Cap LH (FA/FB)

If extra FIPG sticks out on the sealing surfaces of the Camshaft Cap and High-pressure Fuel Pump Drive Case after installation, completely remove the extra FIPG with scraper or the like in the directions indicated with arrows in the chart below before curing.

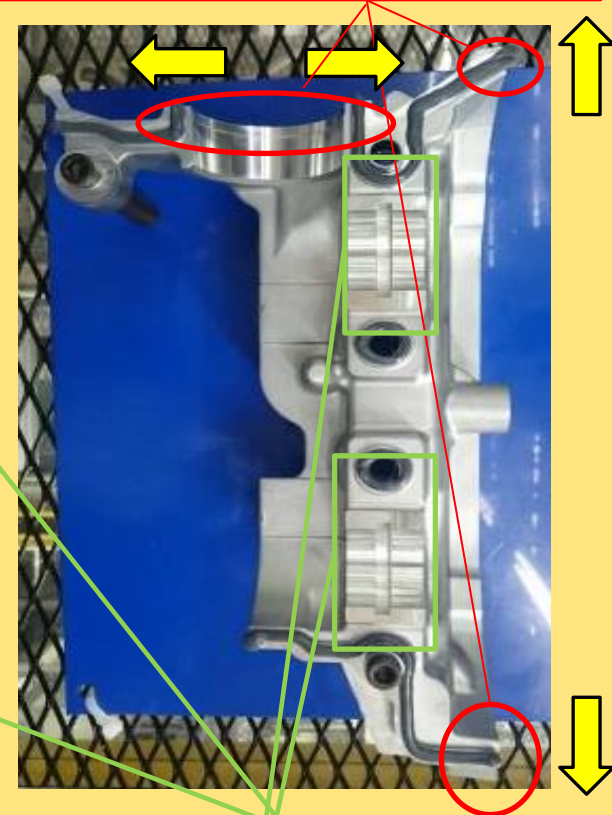
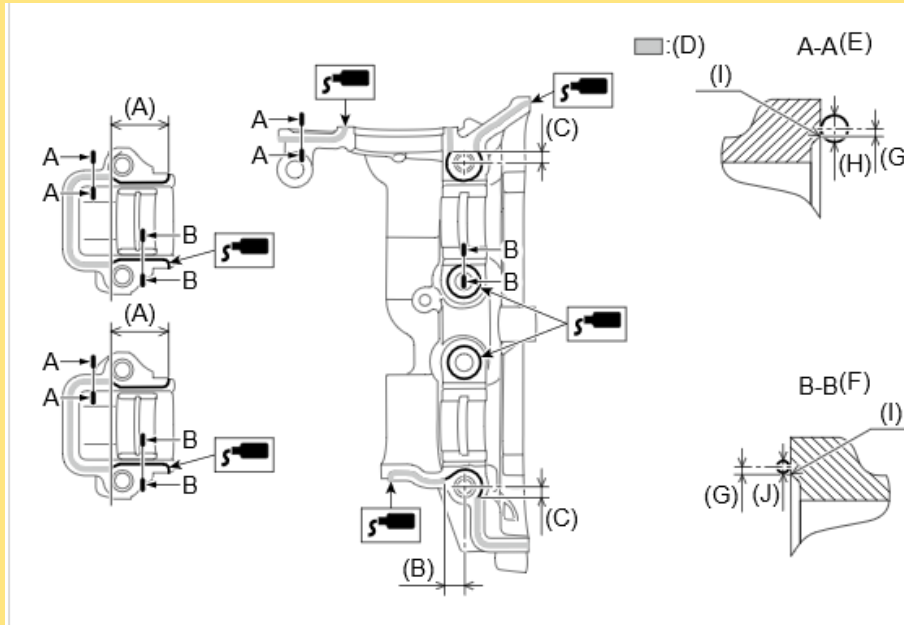

- (A):28.5mm (B):8.5mm (C):5.5mm (D):Range A
- (E):FIPG application position of mating area in Range A
- (F):FIPG application position of mating area other than range A
- (G):1mm (H): $\Phi 3 \pm 0.5$ mm
- (I):Chamfer edge (J): $\Phi 2 \pm 0.5$ mm

Be careful not to apply too much FIPG, otherwise the overflowed FIPG can be bitten by the journal and cause seizure.

Vacuum pump ASSY (FA/FB)

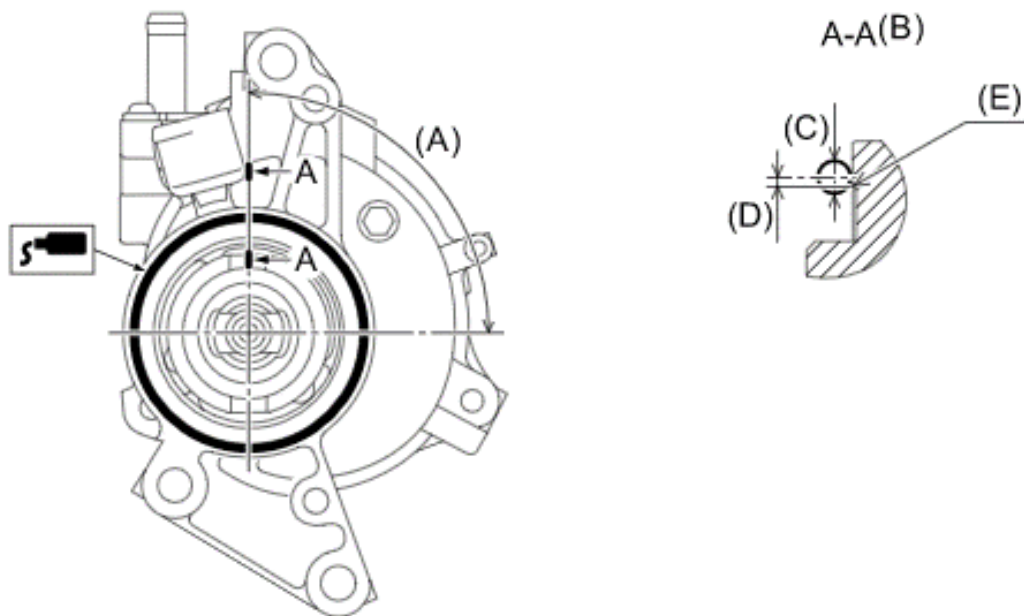

- (A):Range A (possible starting range of application)
- (B):Location of FIPG application on mating surfaces
- (C): $\Phi 3 \pm 1\text{mm}$
- (D):1mm
- (E):Chamfer edge



SUBARU

Confidence in Motion

Plate (FA/FB)

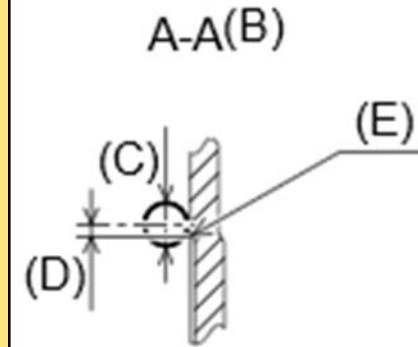
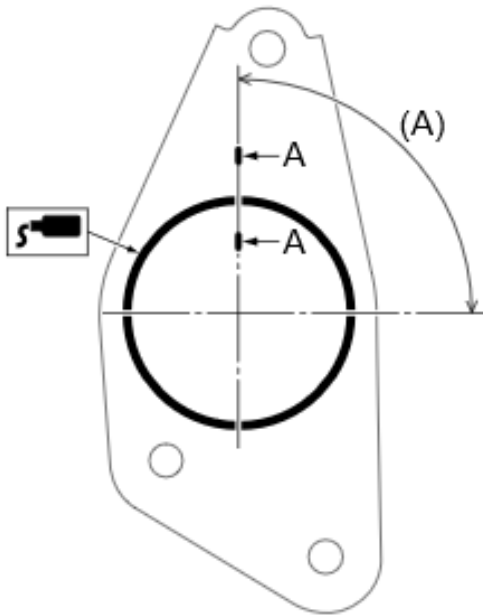

Aim at the chamfer shape of the plate and apply the FIPG.



- (A): Range A (possible starting range of application)
- (B): Location of FIPG application on mating surfaces
- (C): $\Phi 3 \pm 1\text{mm}$
- (D): 1mm
- (E): Chamfer edge

Rocker cover RH (FA/FB)

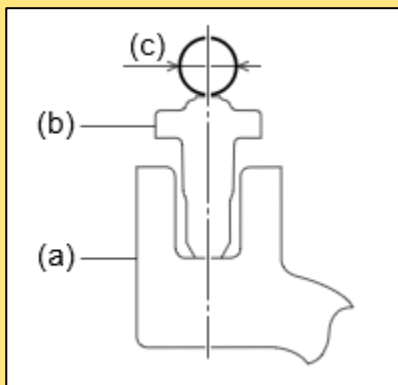
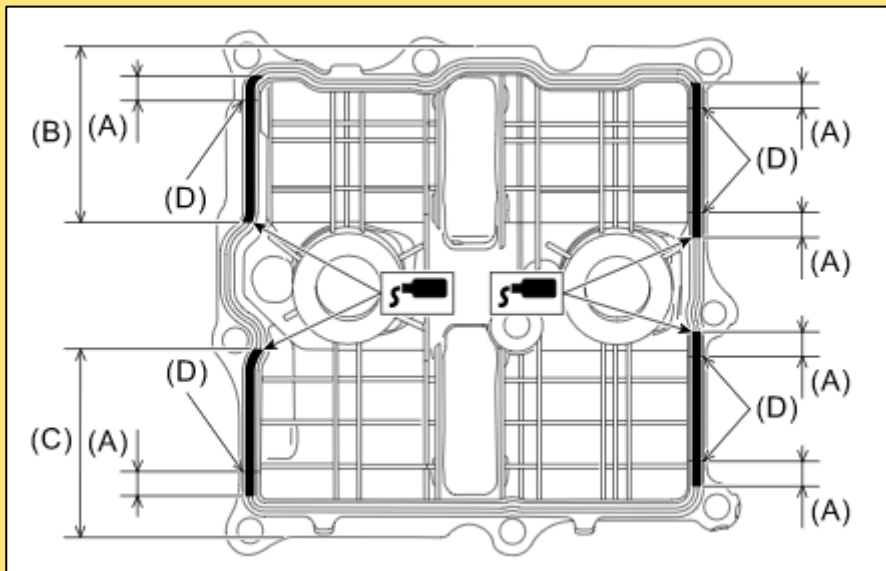

(A):10.0mm or more (B)74mm or less
 (C):71~73mm (D):Starting point of arch
 ※ Please refer to the service manual of each vehicle system.

(a):Locker cover
 (b):Locker cover gasket
 (c): $\Phi 3 \pm 1$ mm

Rocker cover LH (FA/FB)

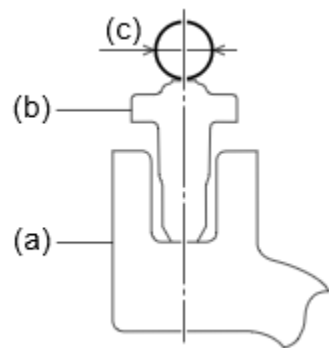
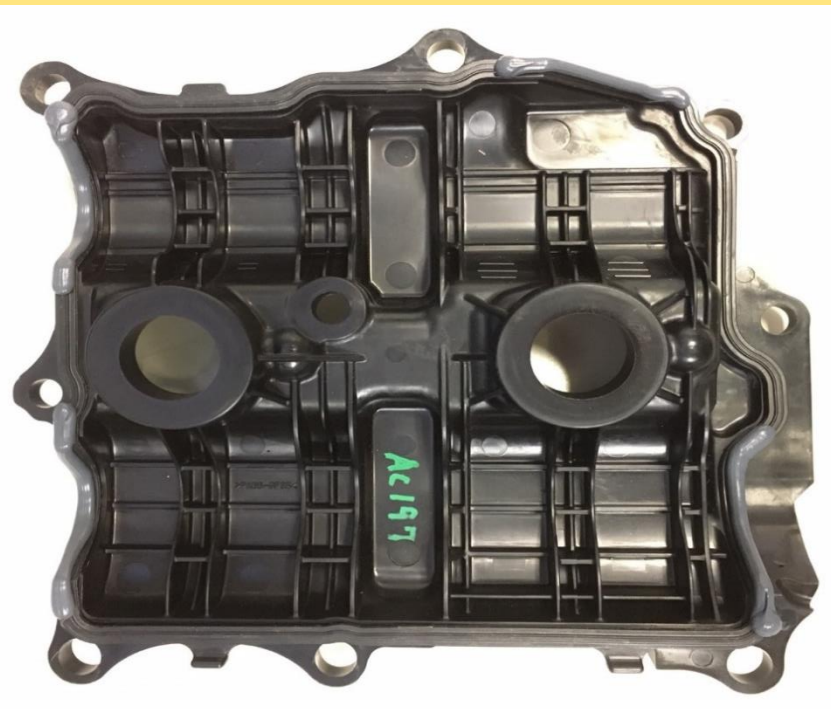
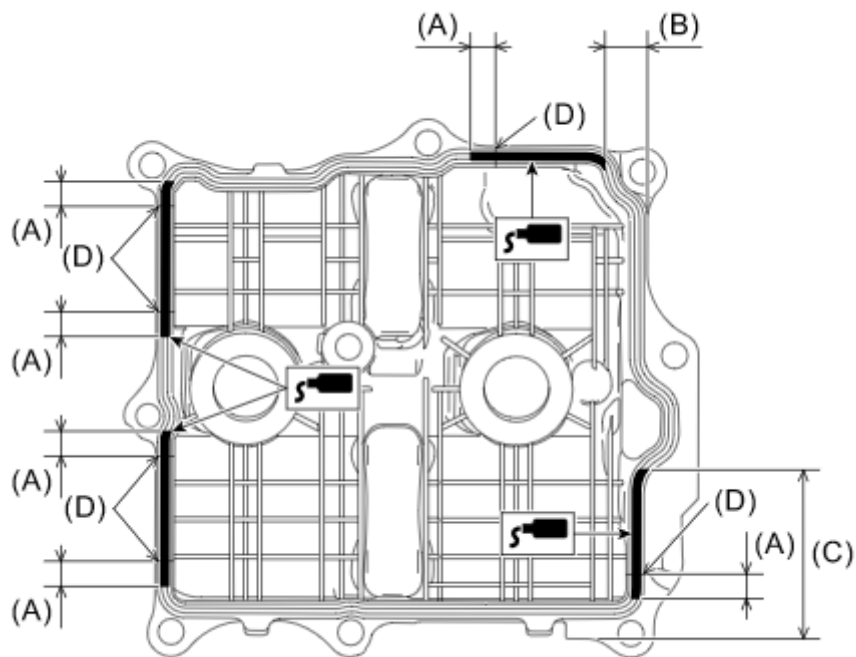

(A):10.0mm or more (B):17.3mm or less
 (C):70.7mm or more (D):Starting point of arch
 ※ Please refer to the service manual of each vehicle system.

(a):Locker cover
 (b):Locker cover gasket
 (C): $\Phi 3 \pm 1$ mm

Oil pan UPR (FA/FB)

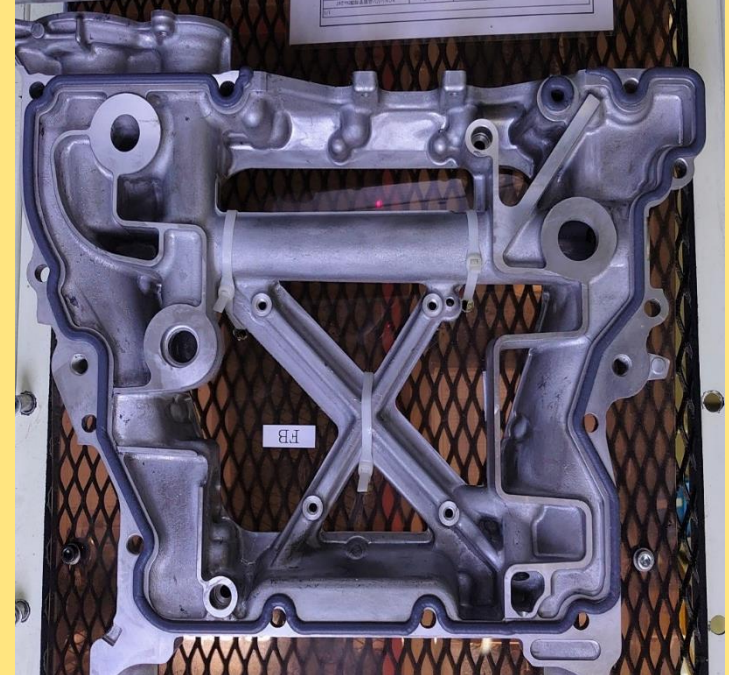
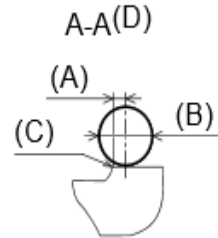
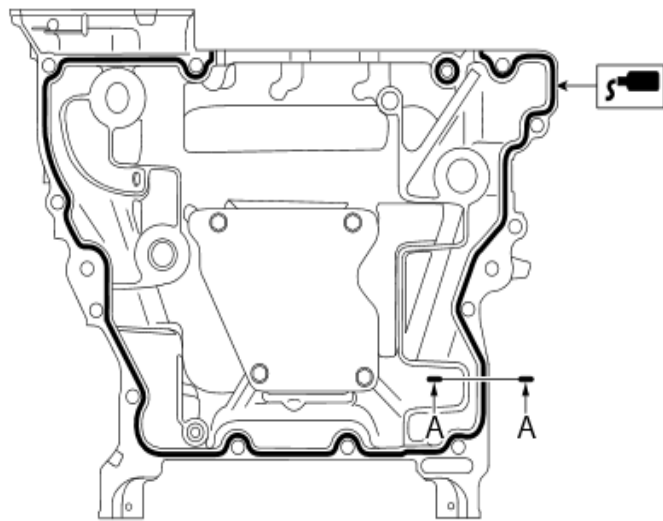

- (A): 0mm or more and less than 2.0mm
- (B): $\Phi 4 \pm 0.5$ mm
- (C): Chamfer edge
- (D): FIPG application position of aligned surface area

Oil pan (FA/FB)

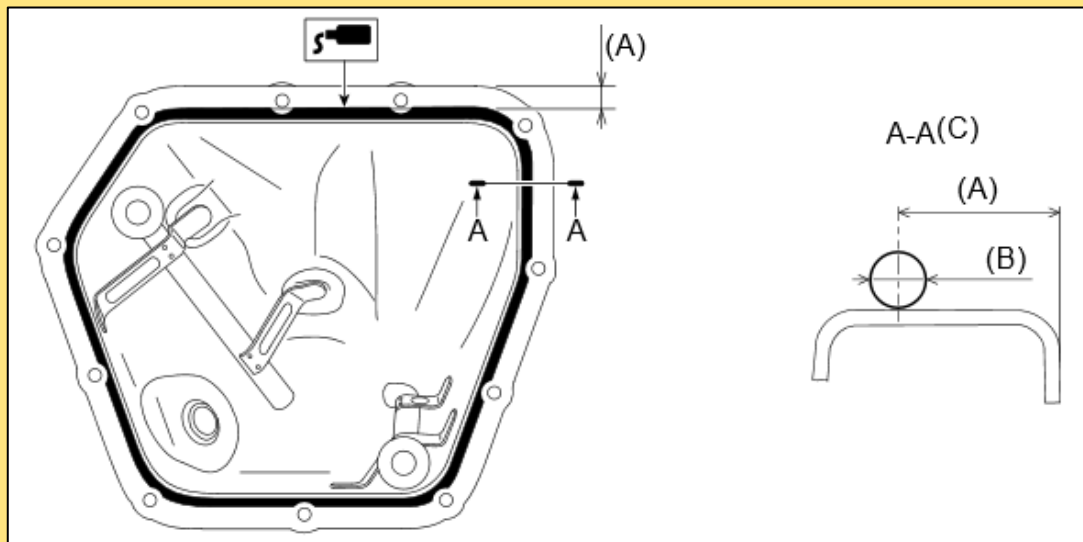

- (A): 10.5mm or more but less than 13.5mm
- (B): $\Phi 4.5 \pm 0.5\text{mm}$
- (C): FIPG application position of aligned surface area



For convenience of photography, the bottom of the oil pan has been cut off.



SUBARU

Confidence in Motion

Chain cover Preliminary check before assembly (FA/FB)

Before assembly the Chain Cover, check if there are any non-flat portions along the mating surfaces especially at the locations shown in the figure. If there is a non-flat portion (dent) make the surface flat by filling with FIPG.

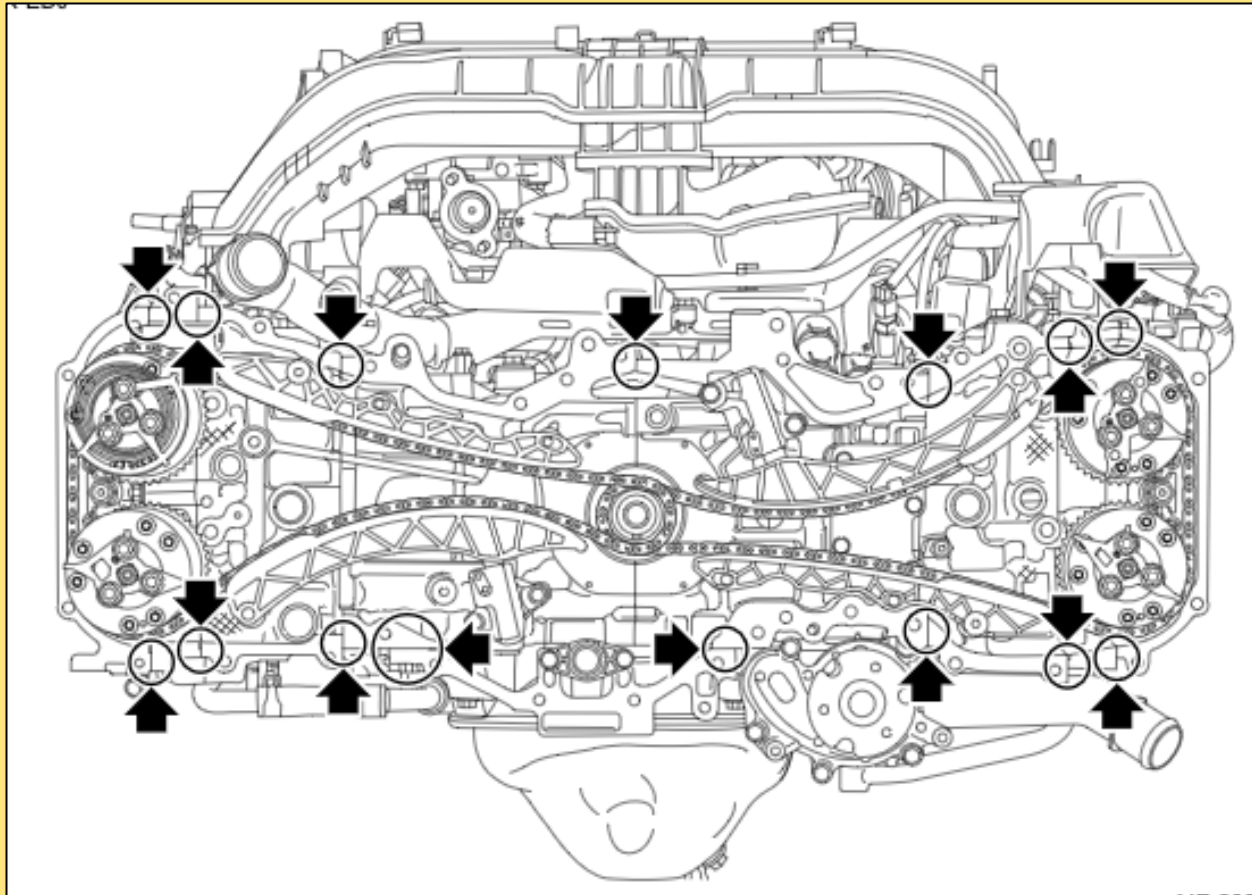

Chain cover (FA/FB)

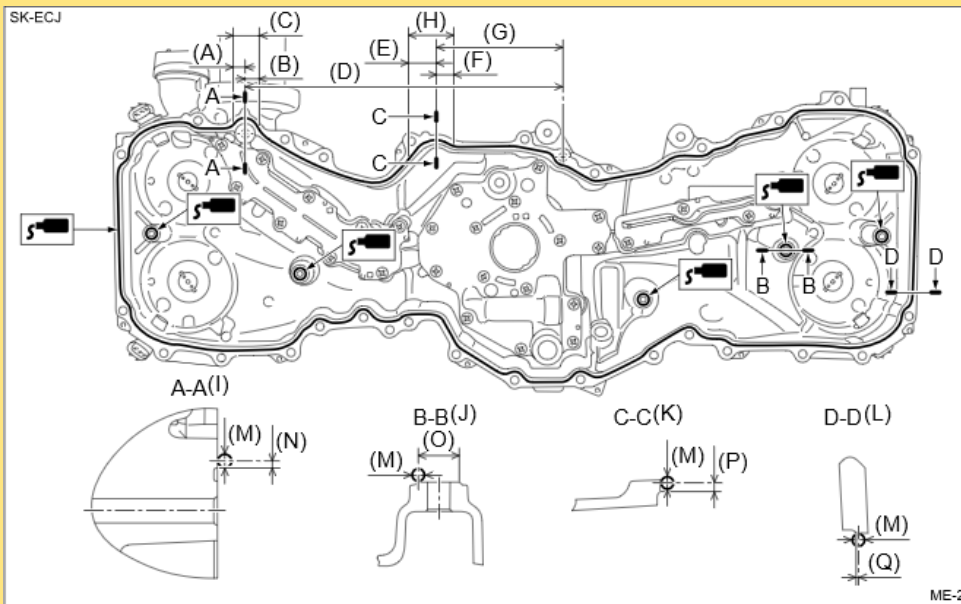

- (A):14.5mm (B):17.5mm (C):Range A (D):316.2mm
 (E):24.5mm (F):18.5mm (G):127mm (H):Range B
 (I):FIPG application position at the mating area in range A
 (J):FIPG application locations on central boss (5 locations)
 (K):FIPG application position at the mating area in range B
 (L):FIPG application locations on mating surfaces other than Range A and Range B
 (M): $\Phi 4 \pm 0.5$ mm (N):2.3mm (O): $\Phi 12$ mm (P):2.8mm (Q):1mm
 ※ Refer to the service manual of each vehicle system for values.