



## STAR ONLINE PUBLICATION



**Case Number:** S2422000002

**Release Date:** September 2024

**Symptom/Vehicle Issue:** Low Tire Pressure. Tire Valve Stem And Tire Pressure Monitor (TPM) Sensor Service.

**Discussion:** Analysis of returned TPM sensor assemblies have shown many sensor kits are being installed for damaged or leaking valve stems. The TPM sensors were tested and found to have no TPM issue. The valve stems are available separate from the sensors if damage occurs, or a leak is found at the stem itself. Over repair or warranty repairs for physically damaged parts may lead to charge back.

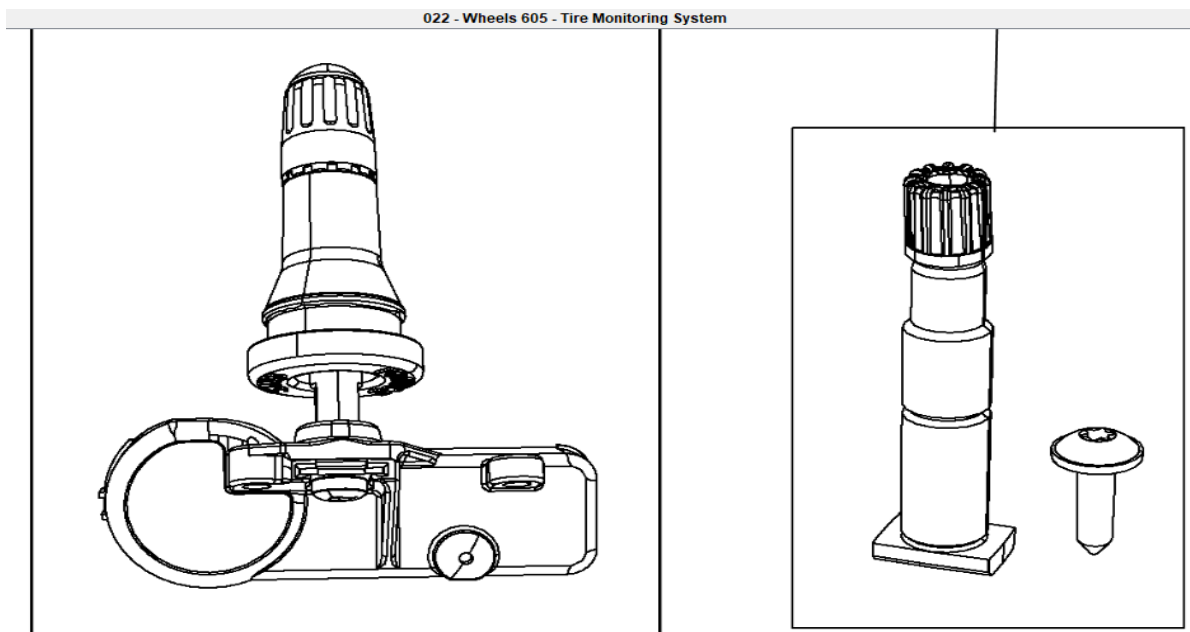

This document does not authorize warranty repairs. This communication documents a record of past experiences. STAR Online does not provide any conclusions about what is wrong with the vehicle. Rather, it captures all previous cases known that appear to be similar or related to the vehicle symptom / condition. You are the expert, and you are responsible for deciding on the appropriate course of action.

**Contact STAR Center, or your Technical Assistance Center Via TechConnect, eCONTACT or Service Library entry if no solution is found.**