



TECHNICAL SERVICE BULLETIN

Classification: AT24-005	Reference: NTB24-045	Date: September 4, 2024
-----------------------------	-------------------------	----------------------------

ENGINE SUPPORT TOOLS

APPLIED VEHICLES: 2020-2024 Sentra (B18)

SERVICE INFORMATION

A new Engine Support Bracket is now available to allow the CVT to be removed from the **APPLIED VEHICLES** without having to remove the engine.

The procedure in this bulletin is different from the procedure currently in the ESM, which will be updated with this information at a later date.

Please refer to the **SERVICE PROCEDURE** in this bulletin for information on how to use these new tools.

Bulletins are intended for use by qualified technicians, not 'do-it-yourselfers'. Qualified technicians are properly trained individuals who have the equipment, tools, safety instruction, and know-how to do a job properly and safely. **NOTE:** If you believe that a described condition may apply to a particular vehicle, DO NOT assume that it does. See your Nissan dealer to determine if this applies to your vehicle.

SPECIAL TOOLS

New or replacement Essential Tools are available from Tech Mate online:
www.techmatetools.com, or by phone: 1-833-397-3493.

- Charging pipe set (1)
 - O-ring (2)

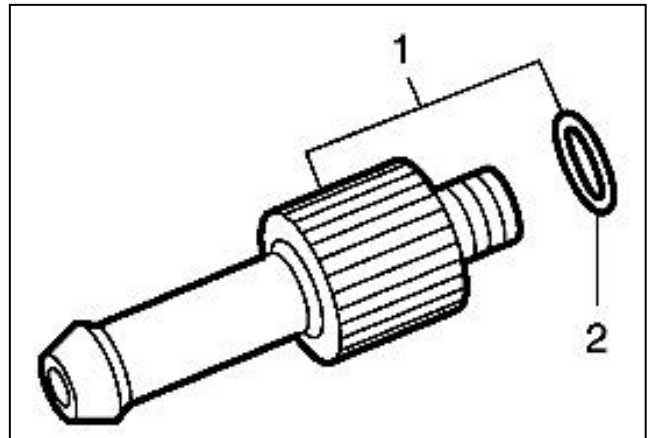

Figure 1

- CVT Stand Pipe Adapter Kit (NI-52584)

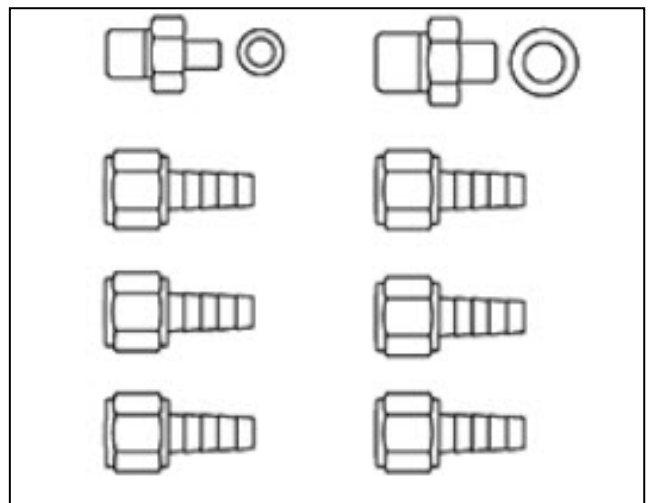

Figure 2

- Differential Side Oil Seal Protector (NI-52469-1)

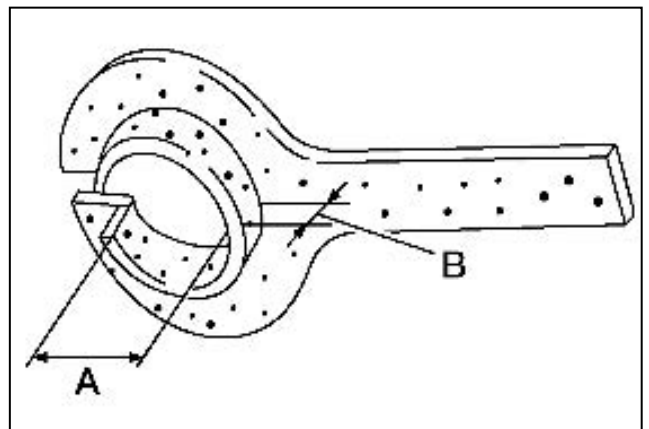

Figure 3

- Engine Support Tool (NI-52389)

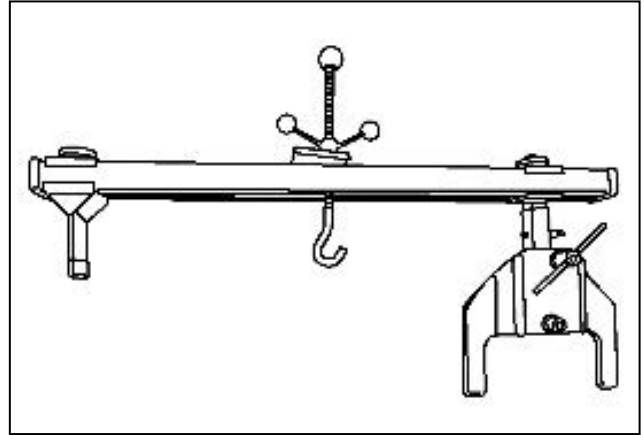

Figure 4

- Engine Hold Tool (NI-53377)

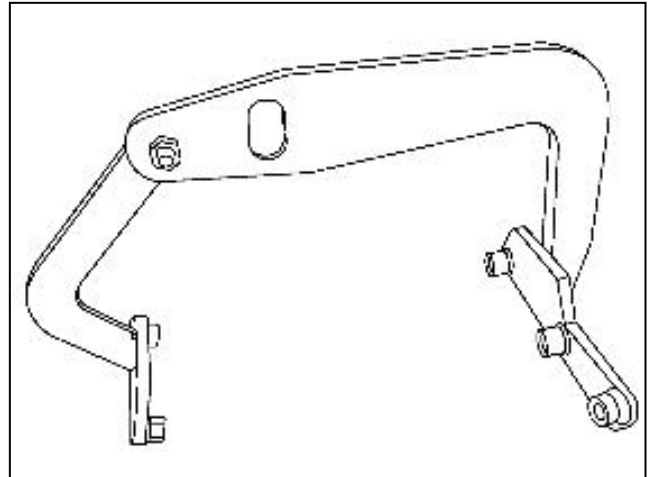

Figure 5

- CVT Transmission Jack Adapter (NI-51307)

HINT: This tool cannot be used on the RE0F15A transaxle (2024 Sentra).

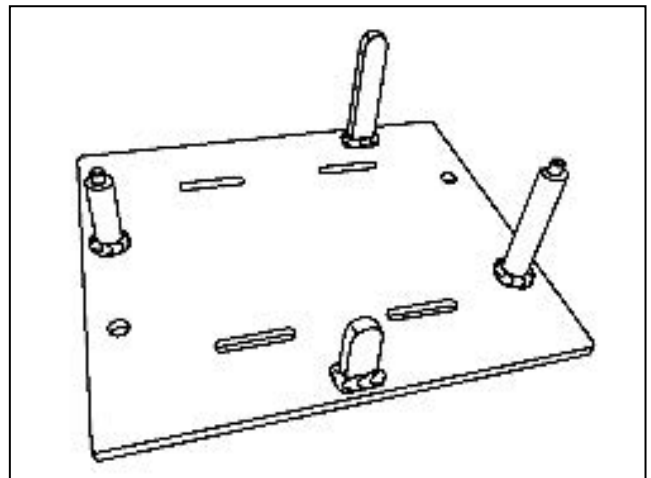

Figure 6

- Torque Adapter

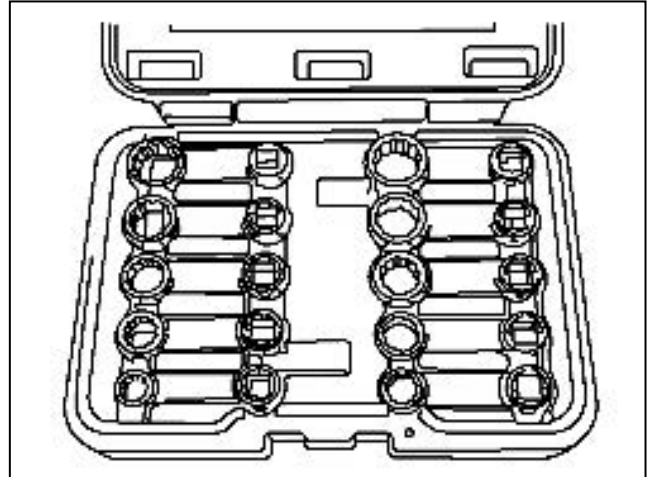

Figure 7

- Power Tool

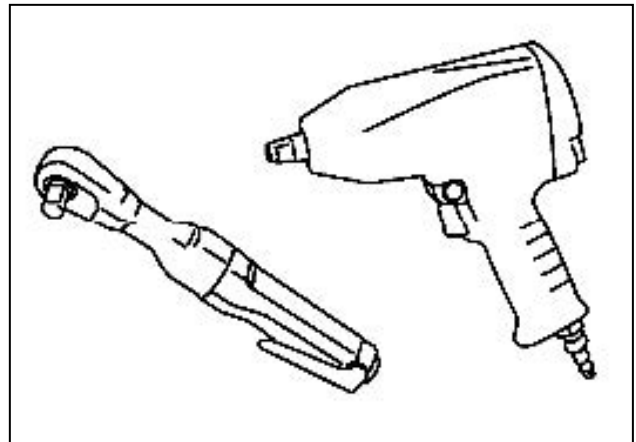

Figure 8

- Hydraulic Lift Table

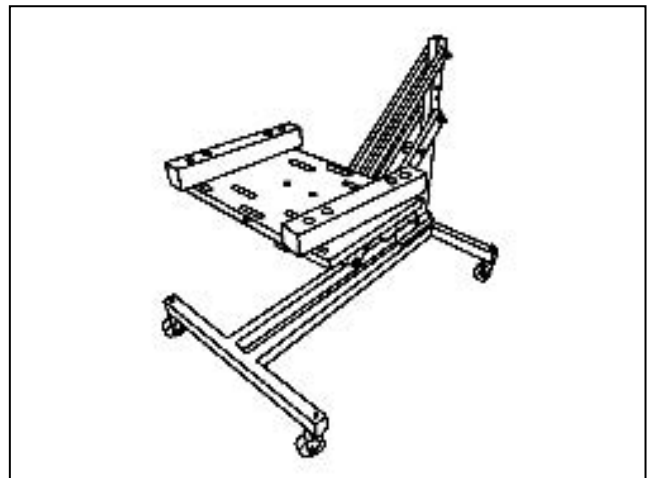

Figure 9

- Transmission Jack

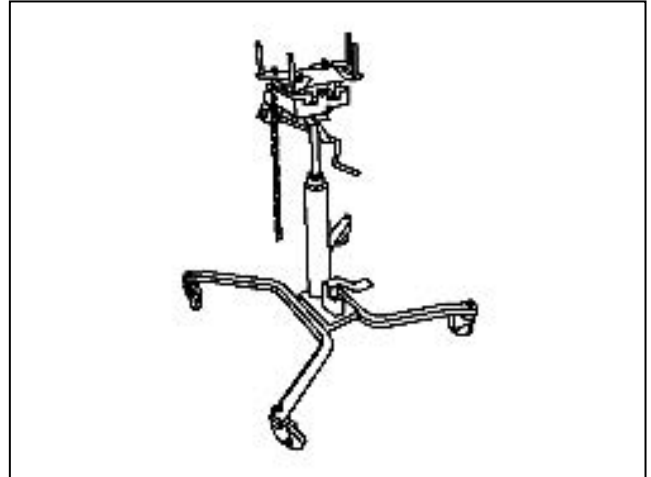

Figure 10

- Driveshaft Joint Puller

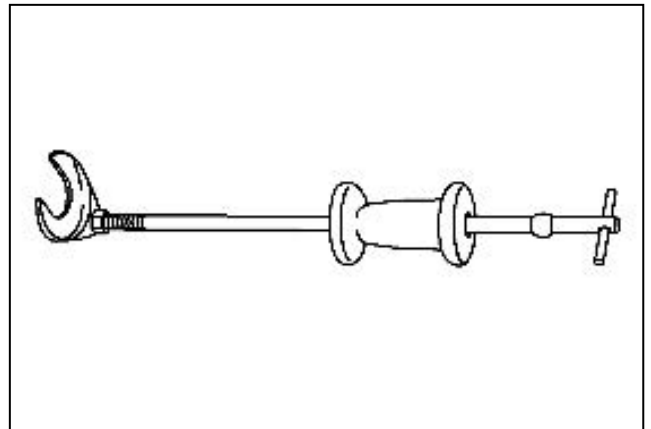

Figure 11

- Ball Joint Remover

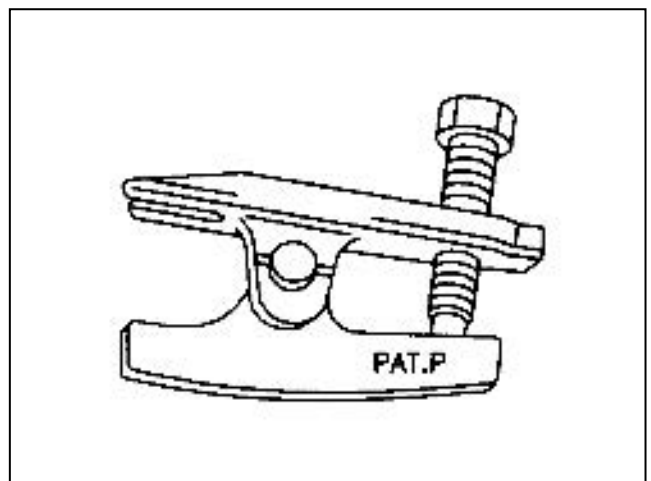

Figure 12

SERVICE PROCEDURE

⚠ WARNING

To avoid the risk of death or severe personal injury, do not remove the radiator cap when the engine is hot. Serious burns could occur from high pressure engine coolant escaping from the radiator. Wrap a thick cloth around the cap. Slowly turn it a quarter turn to allow built-up pressure to escape. Carefully remove the cap by turning it all the way.

⚠ CAUTION

To avoid the risk of minor personal injury or property damage:

- Perform when the engine is cold.
- When replacing the TCM and transaxle assembly as a set, replace the transaxle assembly first and then replace the TCM. Refer to "Description" in the Transaxle & Transmission section of the ESM.
- When replacing the transaxle assembly, perform "ADDITIONAL SERVICE WHEN REPLACING TRANSAXLE ASSEMBLY." Refer to "Description" in the Transaxle & Transmission section of the ESM.

HINT: When removing components such as hoses, tubes/lines, etc., cap or plug openings to prevent fluid from spilling.

Removal

1. Drain the engine coolant from the radiator.
 - Refer to "Changing Engine Coolant" in the Engine Cooling System section of the ESM.
2. Remove the apron bracket.
 - Refer to the Exploded View in the Exterior section of the ESM.
3. Remove the front under cover.
 - Refer to the Exploded View in the Exterior section of the ESM.
4. Remove bolts (A) on the driver (LH) side and passenger (RH) side to partially remove the front half of the front fender protector.
 - Driver (LH) side is shown, passenger (RH) side is similar.

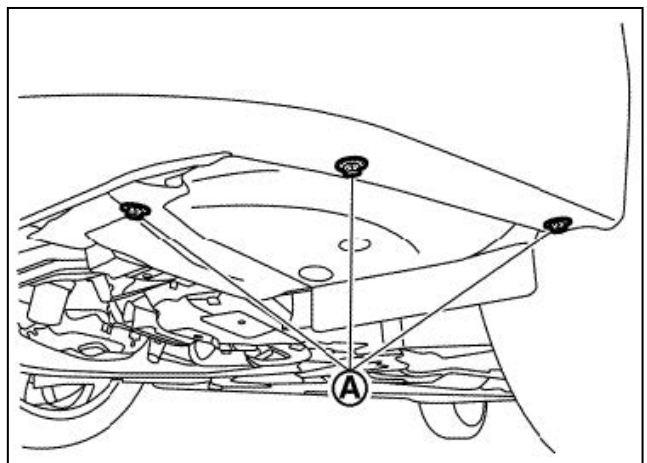

Figure 13

5. Remove clips (A), and then remove the core support cover (1).

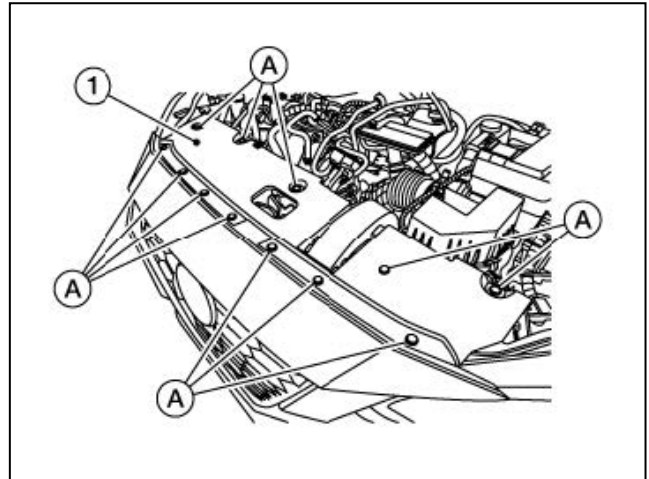

Figure 14

6. Place the steering wheel tilt to its highest position.
7. Center the steering wheel so that the front wheel and tire assemblies are in the straight-ahead position.

⚠ WARNING

To avoid the risk of death or severe personal injury, secure the steering wheel with a string or suitable device to prevent the steering wheel from rotating and damaging the spiral cable.

8. Remove both front wheel and tire assemblies.
9. Remove bolt (A), and then separate the lower joint (1) from the steering gear pinion shaft (2).

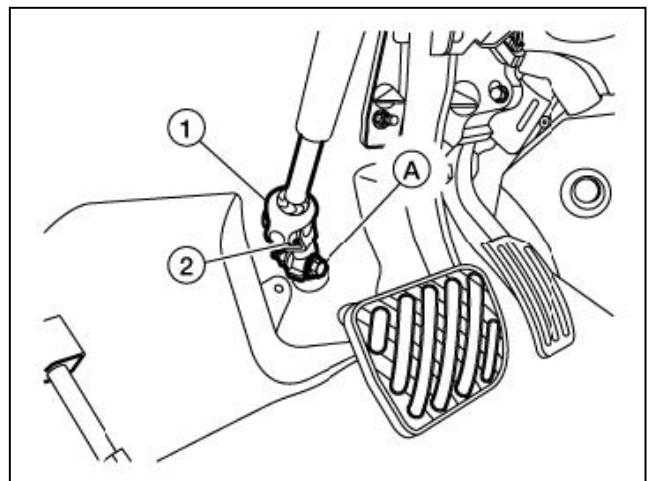

Figure 15

10. Separate the LH and RH side steering outer socket (outer tie rod) from the steering knuckle.

- Refer to the Exploded View in the Steering System section of the ESM.

⚠CAUTION

To avoid the risk of minor personal injury or property damage:

- Do not reuse the outer socket cotter pins.
- Leave the outer socket nuts half threaded on the outer sockets to prevent damage to the threads and to prevent the tool from coming off suddenly.

11. Remove the nuts from both the LH and RH side lower ball joints.

- Discard the nuts, they will not be reused.

12. Separate the transverse link from the steering knuckle using a suitable tool.

- Refer to the Exploded View in the Front Suspension System section of the ESM.

13. Remove the nuts and bolts holding the front bumper reinforcement to the front suspension member.

- Refer to the Exploded View in the Exterior section of the ESM.

14. Remove the exhaust mount from the front suspension member.

- Refer to the Exploded View in the Exhaust System section of the ESM.

15. Remove the rear torque rod.

- Refer to the Exploded View in the Engine Mechanical section of the ESM.

16. Disconnect the electrical connectors from the steering gear.

17. Separate the stabilizer connecting rod from the LH and RH side struts.

- Refer to the Exploded View in the Front Suspension System section of the ESM.

18. Place a suitable jack (A) under the front suspension member.

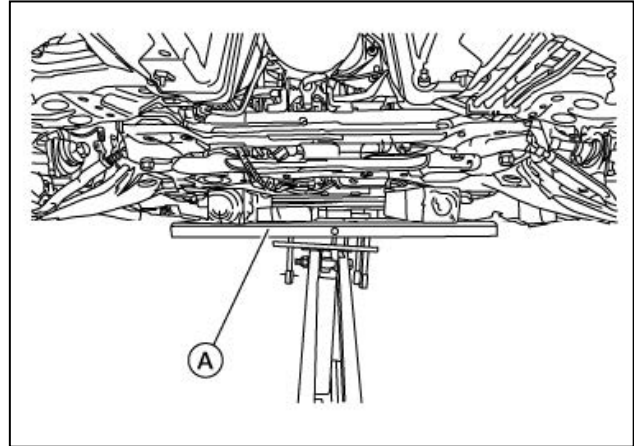

Figure 16

19. Secure the radiator in place prior to removing the front suspension member to prevent the radiator from falling.
20. Remove the two (2) active grille shutter clips from the front lower bumper reinforcement.
21. Remove the six (6) bolts, and then remove the LH and RH side member stays.
22. Remove the front suspension member bolts.
CAUTION
To avoid the risk of minor personal injury or property damage, secure the front suspension member to the hydraulic lift table (or equivalent tool) while removing it.
23. Slowly lower the jack, and then remove the front suspension member from the vehicle.

24. Secure the front bumper reinforcement using a suitable tool (A).

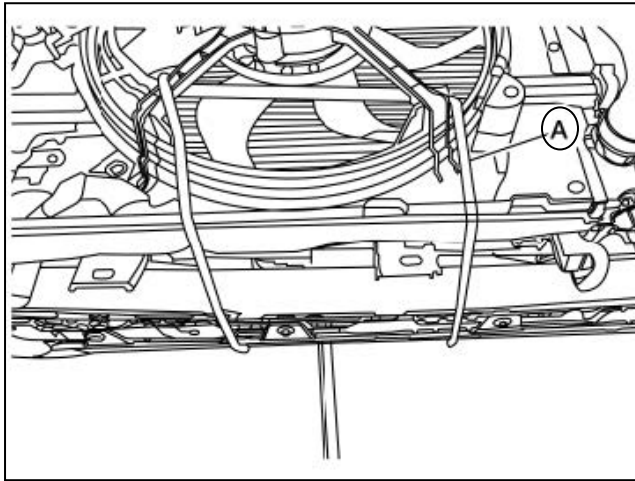

Figure 17

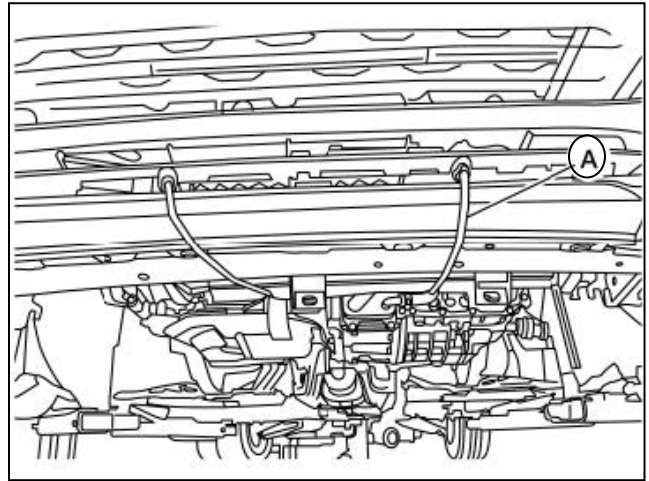

Figure 18

25. Remove the purge valve assembly.
26. Remove the bolts, and then separate the EGR tube from the intake manifold.
- Refer to the Exploded View in the Engine Mechanical section of the ESM.
27. Remove the bolts, and then remove the EGR valve.
- Refer to the Exploded View in the Engine Mechanical section of the ESM.
28. Remove the PCV hose from the intake manifold.
29. Remove the PCV hose from the PCV tube.
30. Disconnect the battery, negative battery cable first.
31. Remove the fusible link cover, and then remove the positive battery cable.
- Refer to “Removal and Installation” in the Power Supply, Ground & Circuit Elements section of the ESM.
32. Remove the battery tray.
- Refer to “Removal and Installation” in the Power Supply, Ground & Circuit Elements section of the ESM.
33. Disconnect the wire harness connector from the Mass Air Flow (MAF) sensor.

34. Remove the wire harness retainer from the upper air cleaner case.
35. Remove the clips, and then remove the air inlet duct.
36. Loosen the clamp connecting the air duct and the resonator assembly to the air cleaner assembly.
37. Remove the bolt, and then remove the air cleaner assembly.
38. Disconnect the wire harness connectors (A) from the ECU, and then release the wire harness retainers.

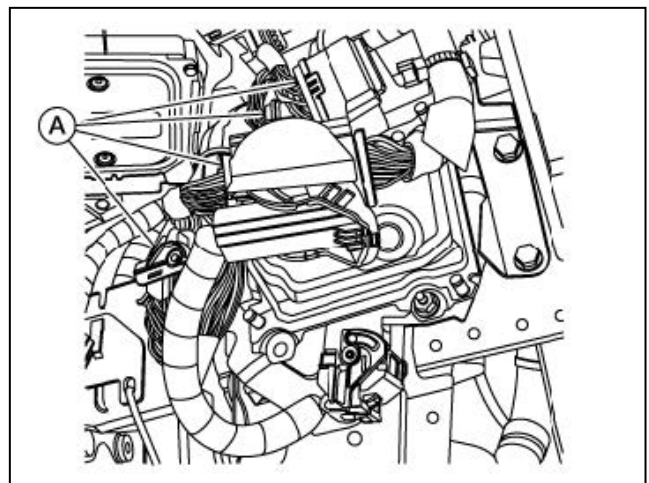

Figure 19

39. Remove the bolts from the ECU bracket and position the ECU aside.
 - Refer to the Exploded View in the Engine Control System section of the ESM.
40. Remove the three (3) main wire harness retainers.
 - Refer to the Exploded View in the Engine Mechanical section of the ESM.
41. Disconnect the EVAP hose from the vacuum delay valve.
 - Refer to the Exploded View in the Fuel System section of the ESM.

42. Disconnect the control cable using the following procedure:

- a. Using a suitable tool, disconnect the control cable (1) from the manual lever.

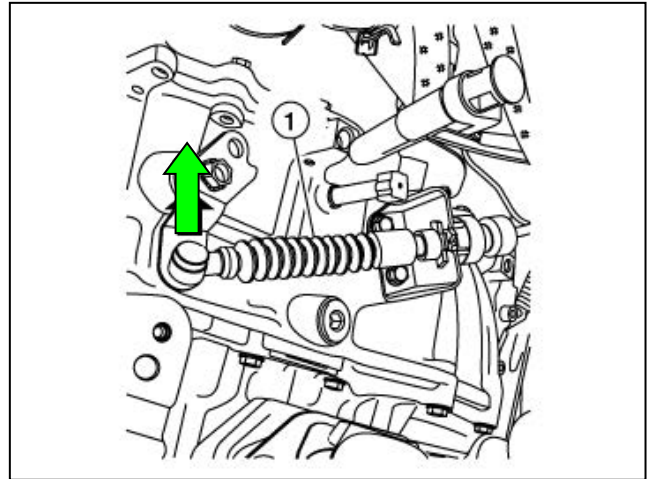

Figure 20

- b. While pressing the locks of the control cable in the direction shown, remove the control cable from the CVT cable bracket.

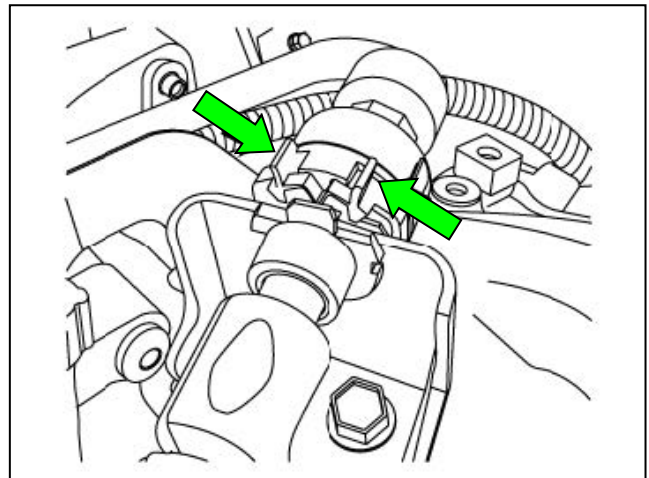

Figure 21

43. Remove bolts (A) from the transaxle assembly.

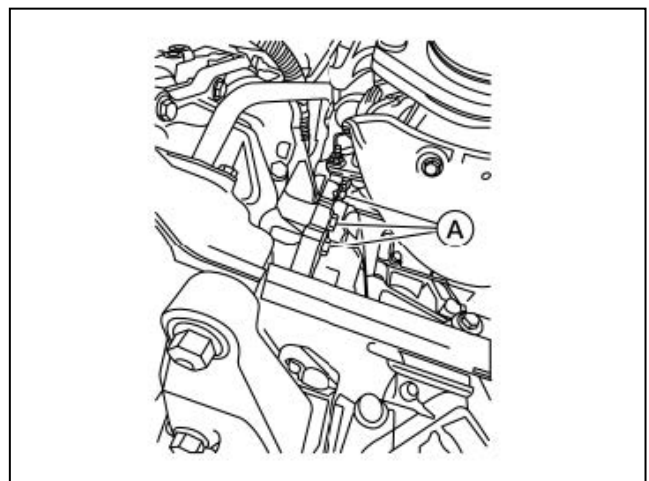

Figure 22

44. Remove the bolts, and then remove the support bearing retainer.

- Refer to the Exploded View in the Front Axle System section of the ESM.

45. Insert suitable tool (A) between the drive shaft and the transaxle, and then remove the LH and RH side drive shafts from the transaxle.

NOTICE

To avoid damage to the drive shaft:

- Confirm that the circular clips are attached to the drive shafts.
- Do not place the drive shaft joints at extreme angles when removing the drive shafts. Also be careful not to overextend the slide joints.
- Do not reuse the circular clips.

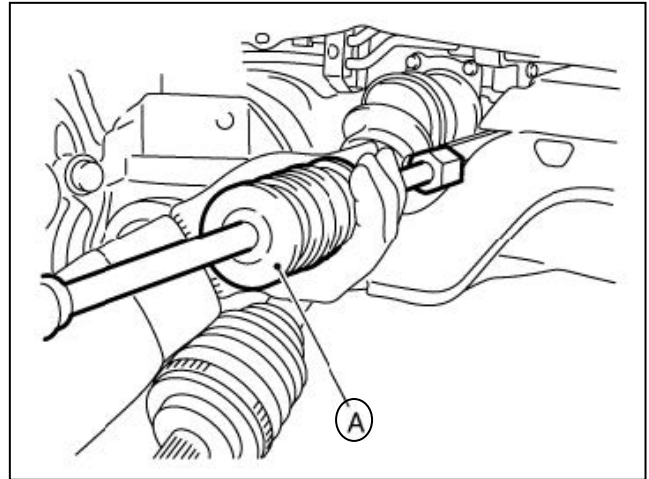

Figure 23

46. Support the LH side drive shaft (1) using a suitable tool (A).

NOTICE

To avoid damage to the drive shaft:

- Do not place the drive shaft joints at an extreme angle.
- Do not over extend the slide joints.
- Do not allow the drive shafts to hang without support.

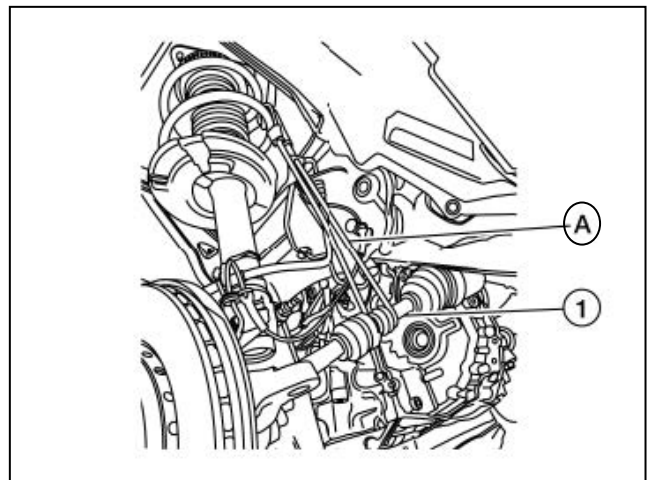

Figure 24

47. Use the bearing support bracket (B) to support the drive shaft (1).

- Use a suitable cloth (A) to protect the drive shaft splines.

NOTICE

To avoid damage to the drive shaft:

- Do not place the drive shaft joints at an extreme angle.
- Do not over extend the slide joints.
- Do not allow the drive shafts to hang without support.

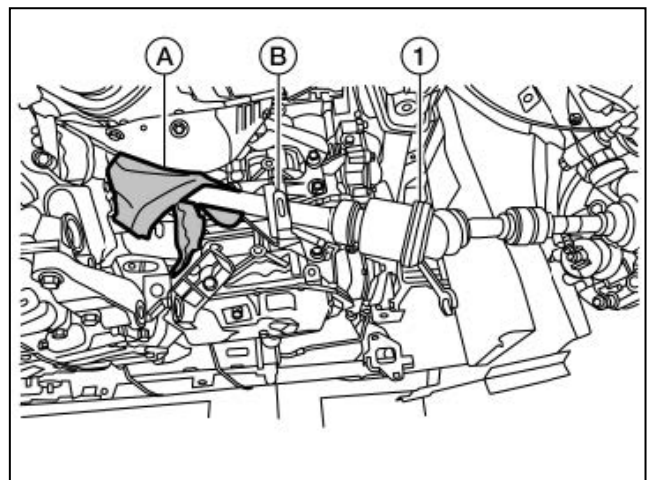

Figure 25

48. Remove the LH and RH side differential side oil seals.
 - Refer to “Removal and Installation” in the Transaxle & Transmission System section of the ESM.

NOTICE

To avoid damage to the differential, do not reuse the differential side oil seals.

49. Disconnect the ground cable from the transaxle assembly.

50. Disconnect the ground cable (A) from the cylinder head.

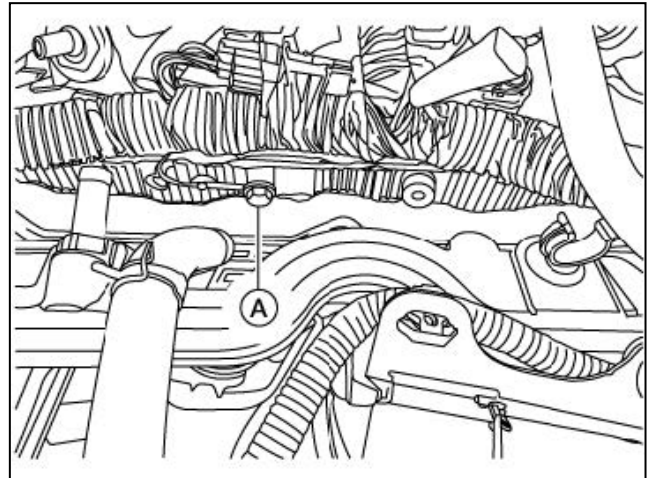

Figure 26

51. Disconnect the wire harness connectors from cylinder two and cylinder three ignition coils.
52. Release the wire harness retainers and reposition the harness aside.
53. Remove the engine control wire harness retainer from the vacuum tube.
54. Remove the vacuum hose from the vacuum pump.
 - Refer to the Exploded View in the Engine Mechanical section of the ESM.
55. Remove the vacuum hose from the intake manifold.
 - Refer to the Exploded View in the Engine Mechanical section of the ESM.
56. Remove the upper transaxle bolt.

57. Using supplied bolts (A), install special tool NI-53377 to the front (Figure 27) and rear (Figure 28) of the cylinder head.

- Refer to the Engine Support Tool Operating Instructions.

- Front of cylinder head.
 - Bolt (A) torque: 23 N•m (2.3 kg-m, **17 ft-lb**)

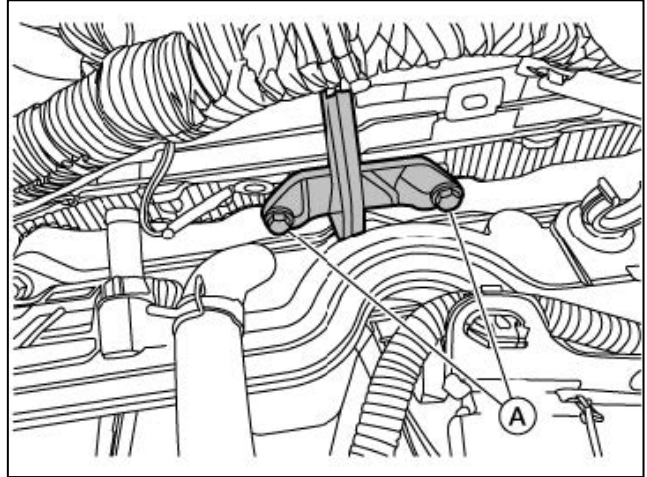

Figure 27

- Rear of cylinder head.
 - Bolt (A) torque: 23 N•m (2.3 kg-m, **17 ft-lb**)

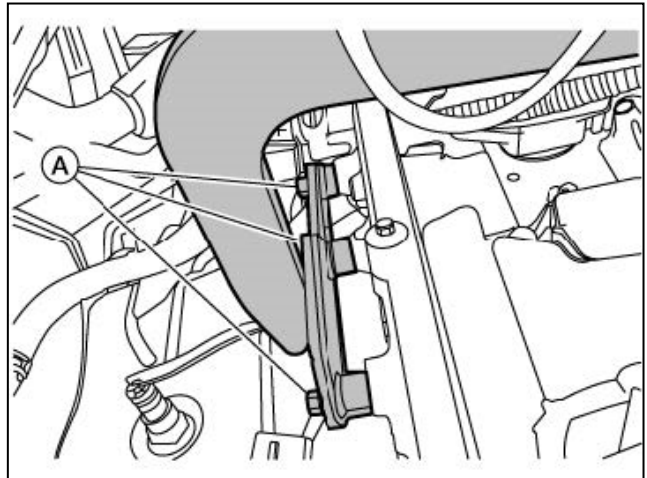

Figure 28

58. Install special tool NI-52389 (A) to the LH side frame rail (1).

- Refer to the Engine Support Tool Operating Instructions.

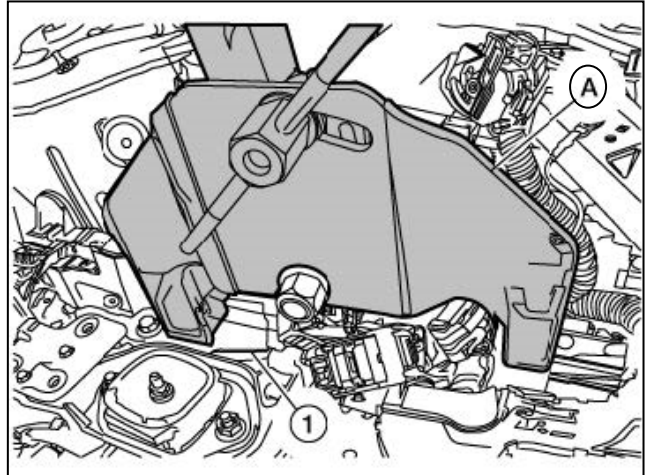

Figure 29

59. Install special tool NI-52389 (A) on top of the RH side engine mounting insulator (1).

- Refer to the Engine Support Tool Operating Instructions.

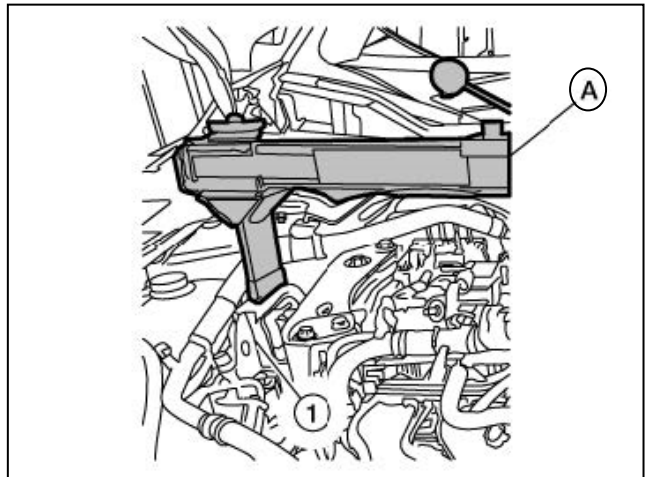

Figure 30

60. Install special tool NI-52389 (A) to special tool NI-53377 (B).

- Refer to the Engine Support Tool Operating Instructions.

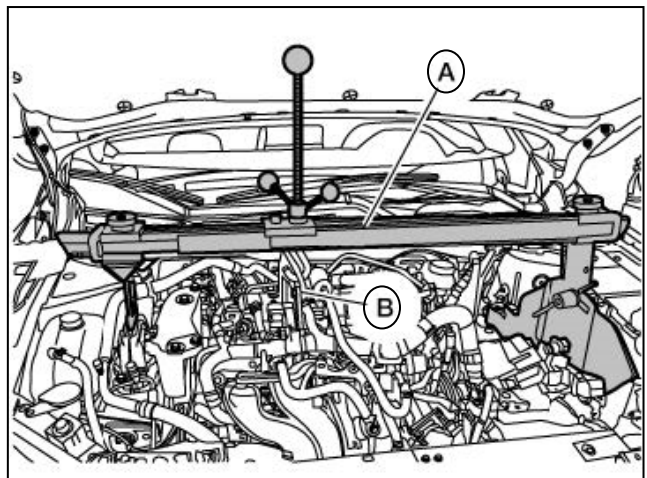

Figure 31

61. Remove nut (A) securing the LH side engine mounting insulator to the LH side engine mounting bracket.

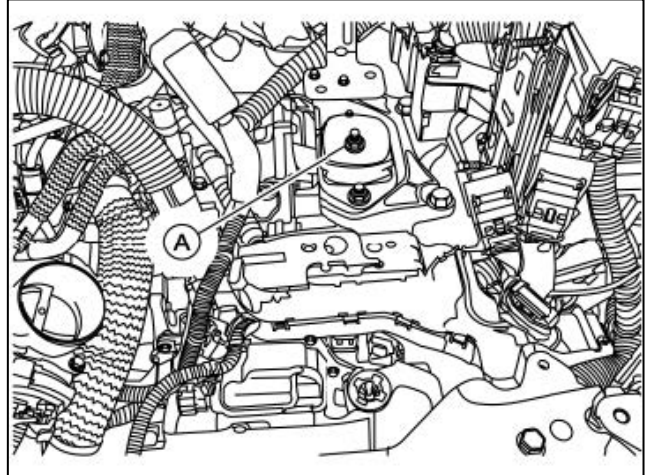

Figure 32

62. Remove the heater thermostat bolt, and then reposition the heater thermostat aside.
- Refer to the Exploded View in the Transaxle & Transmission System section of the ESM.
63. Remove the heater thermostat hoses from the engine oil cooler.
- Refer to the Exploded View in the Engine Lubrication System section of the ESM.

64. Remove the water hoses (1) from the CVT oil warmer.
- Refer to the Exploded View in the Transaxle & Transmission System section of the ESM.

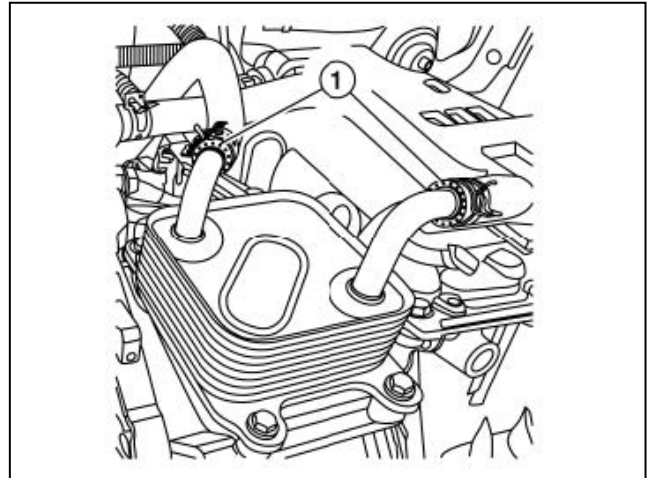

Figure 33

65. Remove the starter motor.
- Refer to “Removal and Installation” in the Starting System section of the ESM.
66. Disconnect the wire harness retainers and reposition the starter motor harness.
67. Disconnect the wire harness connectors from the CVT.
- 2020-2023 Sentra: CVT unit connector, primary speed sensor, secondary speed sensor, output speed sensor, and transmission range switch.
 - 2024 Sentra: CVT control valve, electric oil pump, primary speed sensor, and secondary speed sensor.
68. Remove the wire harness ground bolt, and then remove the wire harness retainers from the CVT and reposition the harness.
69. Remove the rear left bolt from the front fascia bracket.

70. Using a three (3) inch extension, remove the torque converter nuts.
- Refer to the Exploded View in the Transaxle & Transmission System section of the ESM.

71. Using a suitable jack and special tool NI-51307 (A), support the transaxle.

HINT: Special tool NI-51307 will only work for the RE0F10D transaxle (2020-2023 Sentra). The tool will not work on the RE0F15A transaxle (2024 Sentra).

⚠CAUTION

To avoid the risk of minor personal injury or property damage:

- Always secure the transaxle assembly to the transmission jack.
- Do not lift or support the transaxle assembly using the bottom of the oil pan or damage can occur.

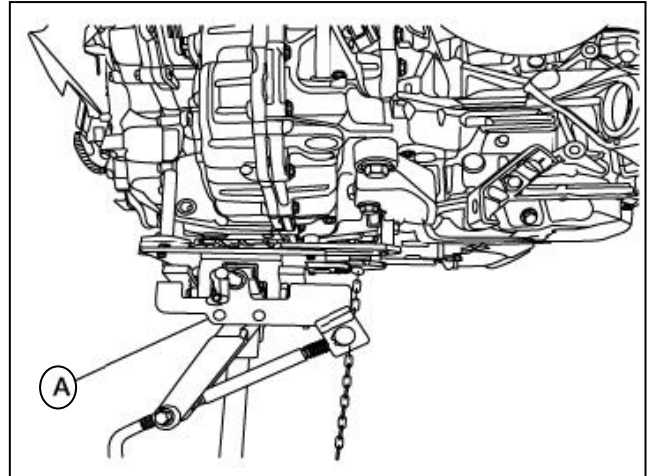

Figure 34

72. Remove the remaining bolts from the transaxle assembly.
- Refer to the Exploded View in the Transaxle & Transmission System section of the ESM.

73. Separate the transaxle from the engine.

⚠CAUTION

To avoid the risk of minor personal injury or property damage, secure the torque converter to the transaxle while removing the transaxle to prevent the torque converter from falling.

74. Slowly lower the transmission jack to remove the transaxle from the vehicle.

Inspection Before Installation

75. After inserting the torque converter into the CVT, check that dimension (A) is within the reference value limit.

- **Dimension A:** Refer to Torque Converter in the SDS Table in the Transaxle & Transmission section of the FSM.
- **B:** Scale
- **C:** Straightedge

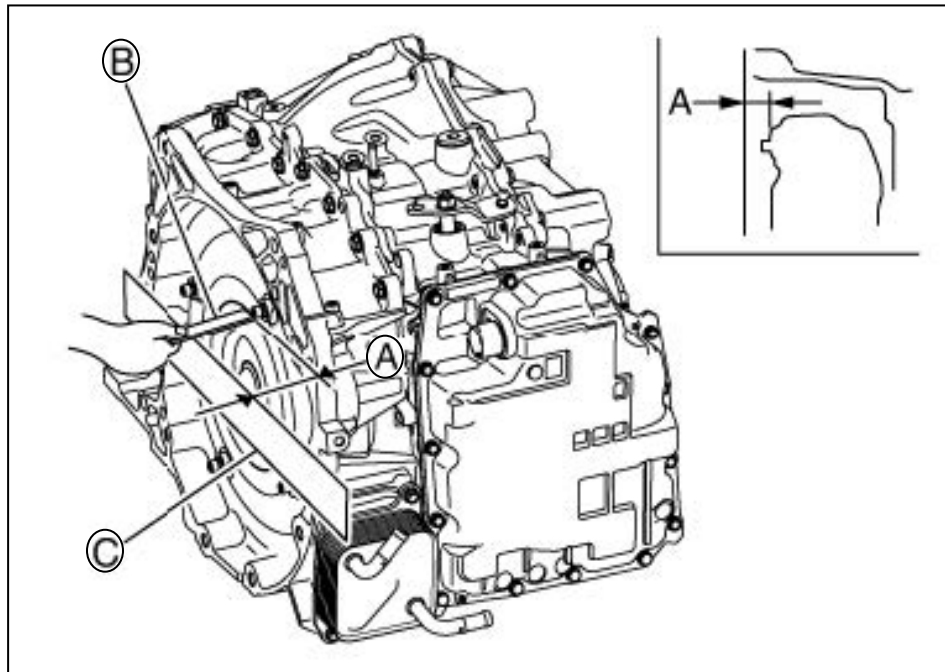

Figure 35

Installation

⚠ CAUTION

To avoid the risk of minor personal injury or property damage:

- When replacing an engine or transaxle you must make sure any dowels are installed correctly during re-assembly.
- Improper alignment caused by missing dowels may cause vibration, oil leaks, or breakage of drivetrain components.
- Do not reuse O-rings or copper sealing washers.
- When turning crankshaft, turn it clockwise as viewed from the front of the engine.
- When tightening the nuts for the torque converter while securing the crankshaft pulley bolt, be sure to confirm the tightening torque of the crankshaft pulley bolt.
 - Refer to the Exploded View in the Engine Mechanical section of the ESM.
- After the torque converter is installed to the drive plate, rotate crankshaft several turns to check that the CVT rotates freely without binding.
- When installing the CVT to the engine, align the matching mark on the drive plate with the matching mark on the torque converter.
- Do not reuse differential side oil seals.
- Do not lubricate engine assembly mounting bolts.
- Do not allow engine oil to get on the engine mounting insulator.
- Be careful not to damage the engine mounting insulator.
- Check that each engine mounting insulator is seated properly, and then tighten the nuts and bolts.

76. Installation is in the reverse order of removal.

- If the same transaxle assembly will be reinstalled, replace the LH and RH side differential side oil seals.
 - Refer to the Exploded View in the Transaxle & Transmission section of the ESM.
- If a new transaxle assembly is being installed, write down the serial number of the new transaxle assembly (A).

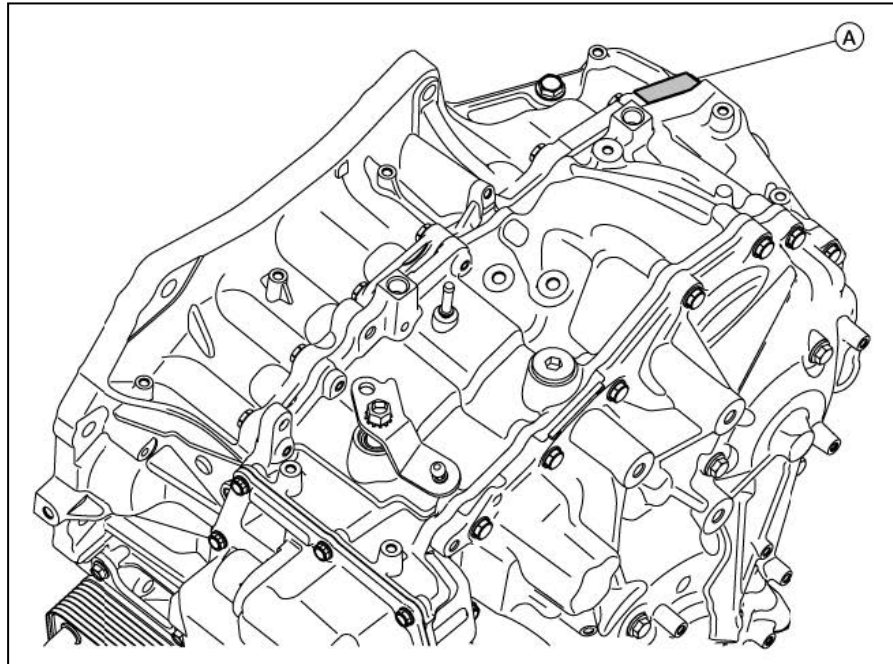

Figure 36

HINT:

- When installing the drive plate to torque converter nuts, tighten them temporarily, and then tighten the nuts to the specified torque.
 - Refer to the Exploded View in the Transaxle & Transmission section of the ESM.
- Install the transaxle assembly and engine assembly mounting bolts according to the following standards:

Bolt symbol	(A)	(B)	(C)
Insertion direction	Transaxle to cylinder block	Cylinder block to transaxle	Oil pan to transaxle
Quantity	1	3	4
Bolt length * ℓ * mm (in)	55 (2.17)	50.5 (1.988)	50.5 (1.988)
Tightening torque N·m (kg·m, ft·lb)	62.0 (6.3, 46)		

Figure 37

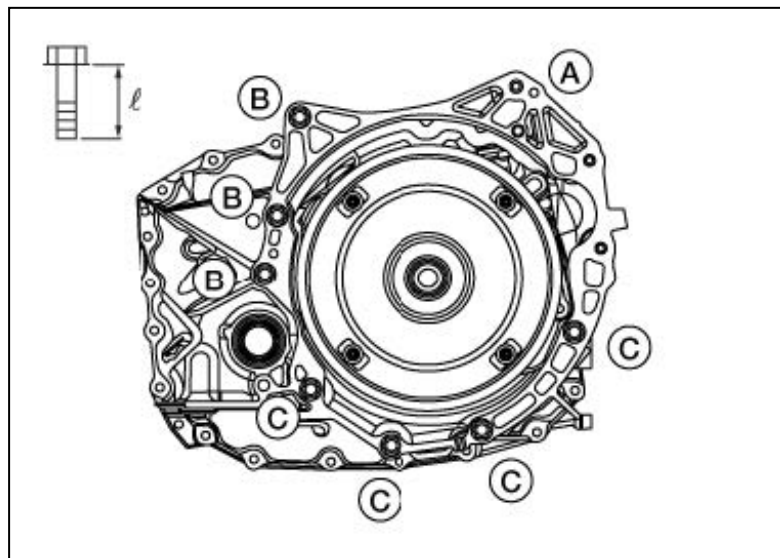

Figure 38

77. After replacing the transaxle assembly, perform “ADDITIONAL SERVICE WHEN REPLACING TRANSAXLE ASSEMBLY”.
 - Refer to “Description” in the Transaxle & Transmission section of the ESM.
78. After installation of the transaxle assembly, refer to “Inspection” in the Transaxle & Transmission section of the ESM.
79. Refill the engine coolant.
 - Refer to “Refilling” in the Engine Cooling System section of the ESM.

⚠ WARNING

To avoid the risk of death or severe personal injury, ensure that the circular clip is properly engaged, otherwise the joint sub-assembly could pull away from the transaxle during vehicle operation resulting in loss of drive force and possible drive shaft damage, which may cause a crash and serious injury.

⚠ CAUTION

To avoid the risk of minor personal injury or property damage:

- Do not reuse the drive shaft circular clip.
- Make sure the new circular clip on the drive shaft is securely fastened and engaged in the groove.

80. When installing the LH and RH side driveshafts:

- Install new circular clips on the drive shaft in the circular clip groove on the transaxle side of the drive shaft.
- In order to prevent damage to the differential side oil seals, place special tool (NI-52469-1) (A) on to the oil seal before inserting the drive shaft.
- Slide the drive shaft into the slide joint, and the tap with a suitable tool to install securely.
- To ensure the circular clip is properly engaged, pull the joint sub-assembly (1) in the direction shown in Figure 40, away from the transaxle assembly, while listening for a clicking sound.

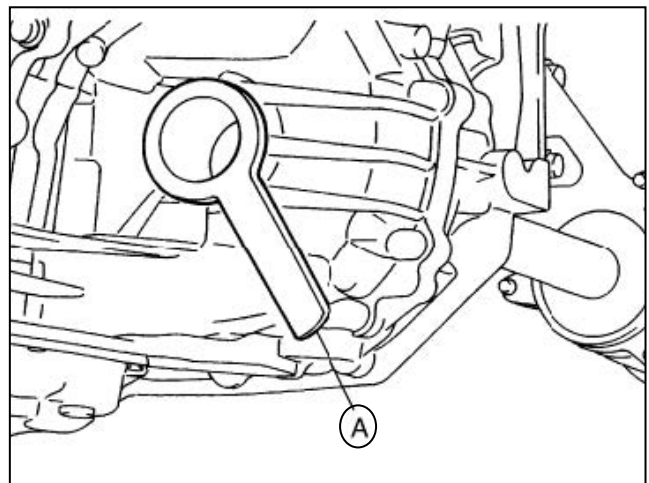

Figure 39

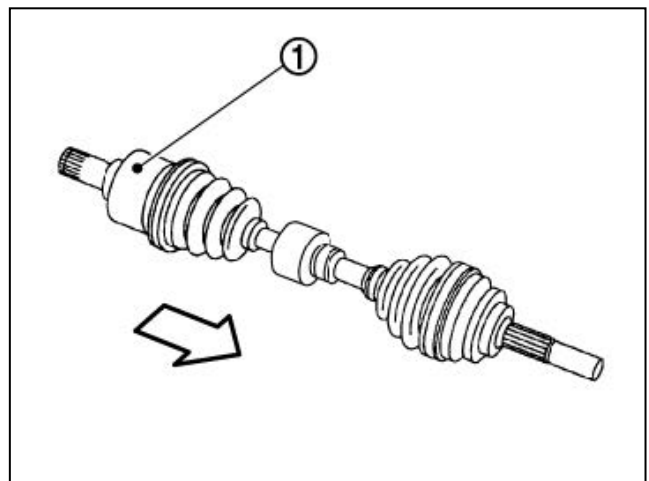

Figure 40

81. Perform a front wheel alignment.
 - Refer to “Wheel Alignment” in the Front Suspension System section of the ESM.

82. Perform the adjustment of the steering angle sensor neutral position.
 - Refer to “Description” in the Brake Control System section of the ESM.

Inspection After Installation

83. Inspect the following items:
 - Start the engine and inspect for coolant leaks.
 - Inspect for CVT fluid leakage.
 - Refer to "Inspection" in the Transaxle & Transmission section of the ESM.
 - Inspect the CVT shifter position.
 - Refer to "Inspection" in the Transaxle & Transmission section of the ESM.

Adjustment After Installation

84. Adjust the CVT fluid level.
 - Refer to "Adjustment" in the Transaxle & Transmission section of the ESM.

CLAIMS INFORMATION

Submit a Primary Part (PP) type line claim using the following claims coding:

DESCRIPTION	OP CODE	FRT
CVT R & I	JD01AA	(1)

- (1) The new procedure in the bulletin will alter the Flat Rate Time (FRT) for operations involving removal of the CVT from the vehicle. Refer to the current Nissan Warranty Flat Rate Manual for the current FRTs.

AMENDMENT HISTORY

PUBLISHED DATE	REFERENCE	DESCRIPTION
September 4, 2024	NTB24-045	Original bulletin published

