

# Clean Idle Labels

Vehicles spec'd with CARB certifications will receive both the CARB and EPA Clean Idle Labels. Those with only an EPA certification will only receive an EPA label. Stickers can be placed on the hood or the door.

**CARB (+EPA)  
Certified**



**EPA Certified**



## Placement Examples

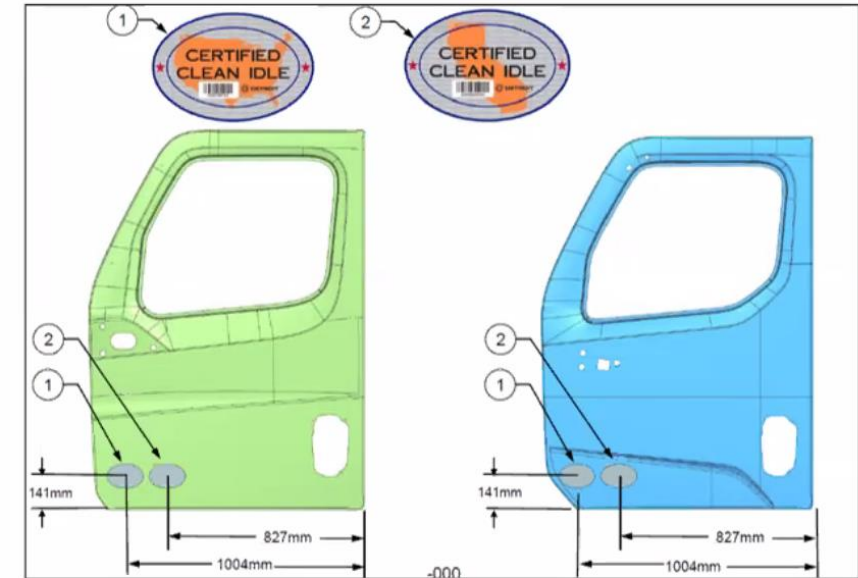
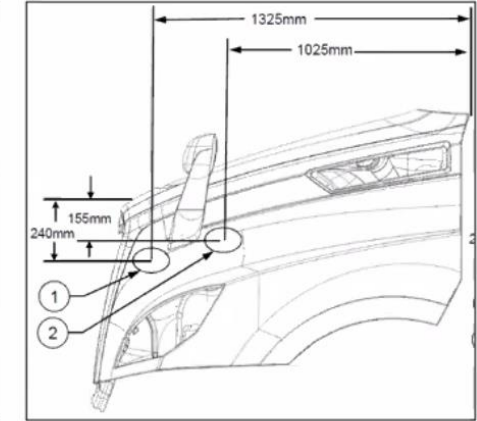
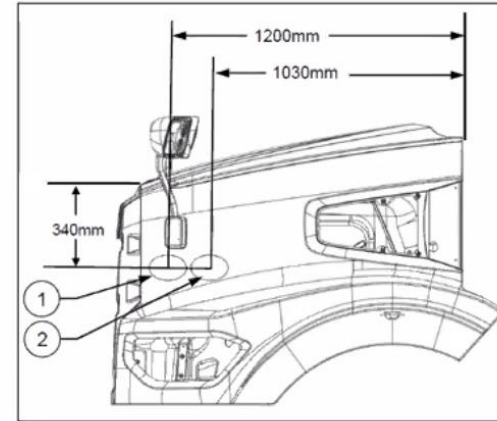

**Note:** The M2 106 will require the dual label option to be placed on the door due to the size of the hood.

# Replacement Labels

The majority of orders received by the call center staff are for the incorrect label or label combination

- People requesting an EPA label when the unit can only have a CARB label.

We believe most of the confusion is due to – the change from one option for clean idle to three (CARB, EPA, or both).

- Suspected people are confused on what to select so they're just picking one.
- It seems most of them are going with the EPA option and hoping for the best
  - Guessing isn't helping the situation