



Service Bulletin

Bulletin No.: 18-NA-150

Date: August, 2024

INFORMATION

Subject: 6.6L Duramax Diesel Engine Possible Oil Leak Path Information

Brand:	Model:	Model Year:		VIN:		Engine:	Transmission:
		from	to	from	to		
Chevrolet	Silverado	2017	2018	—	—	L5P, L5D	—
	Silverado 2500/3500	2019	2025				
	Silverado 4500HD, 5500HD, 6500HD	2019	2025				
GMC	Sierra	2017	2018	—	—	L5P, L5D	—
	Sierra 2500/3500	2019	2025				

Involved Region or Country	North America, Middle East, Israel, South America, Thailand, Australia/New Zealand
Additional Options (RPOs)	Equipped with 6.6L Diesel Engine (RPO L5P or L5D)

Important: Service agents must comply with all International, Federal, State, Provincial, and/or Local laws applicable to the activities it performs under this bulletin, including but not limited to handling, deploying, preparing, classifying, packaging, marking, labeling, and shipping dangerous goods. In the event of a conflict between the procedures set forth in this bulletin and the laws that apply to your dealership, you must follow those applicable laws.

This document is to help identify where to look for an oil leak on the 6.6 Duramax engine.

Note: Please keep in mind that a leak on the top of the engine will trail down the back side of the engine and appear as a rear cover leak. Please use the illustrations below as a guide of where to look for a potential oil leak. These Illustrations are of a L5P engine; the L5D would be similar.

Possible Oil Leak Paths

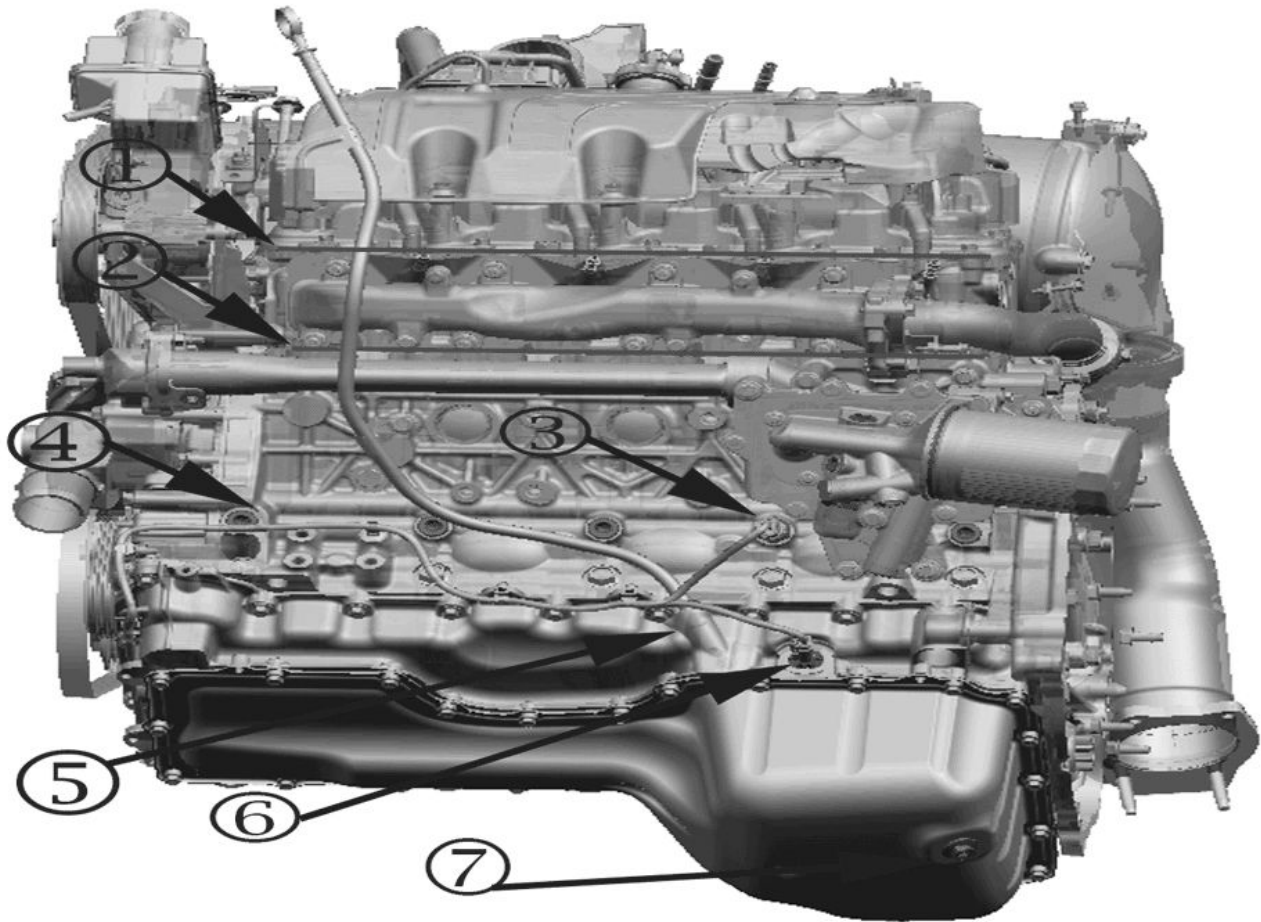

5053868

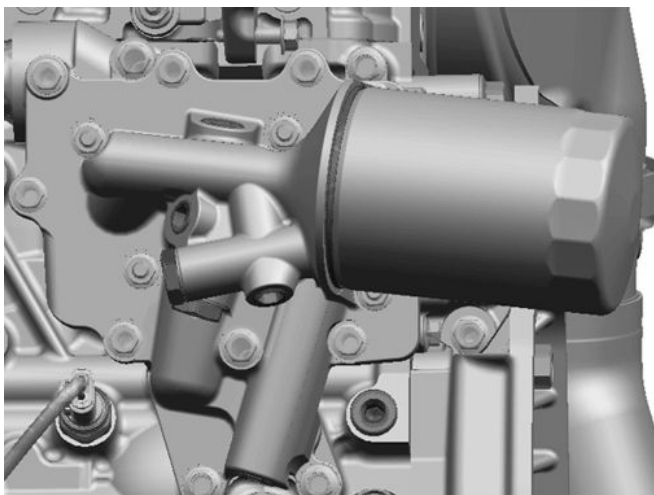

Plugs and Gaskets in Oil Cooler and Filter

5053869

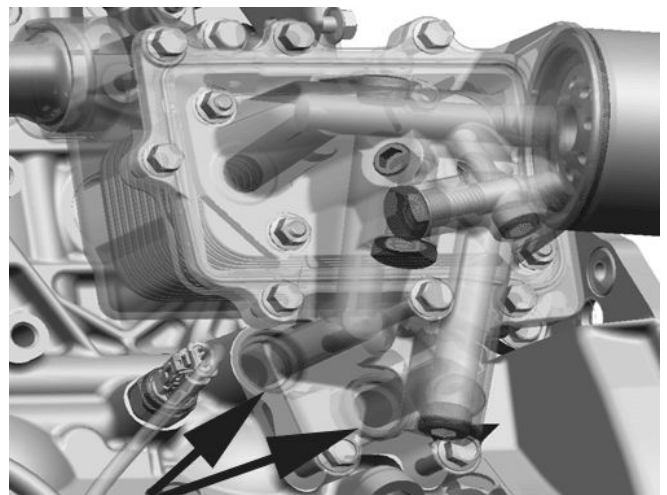

Ghost view of the Oil Cooler Cover to reveal 2 O-rings (SEAL, ENG OIL CLR).

5053871

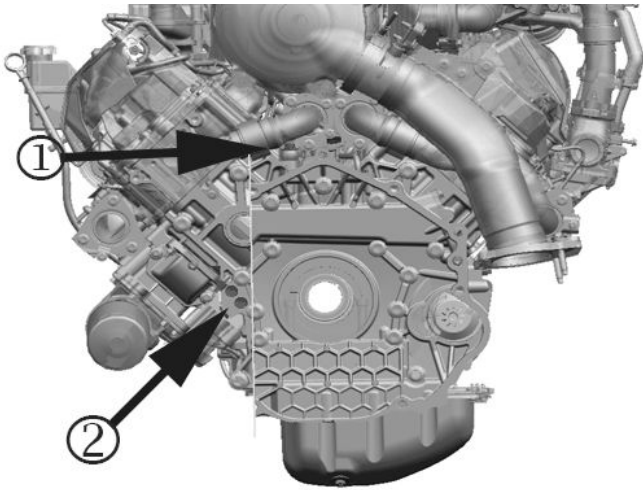

5053872

5053874

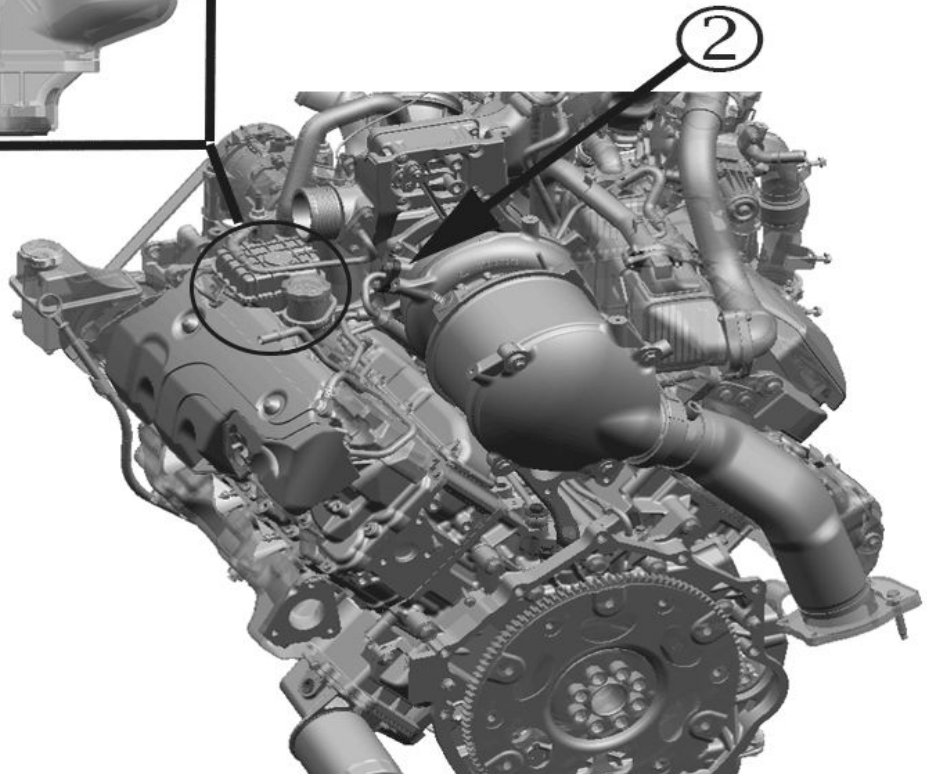
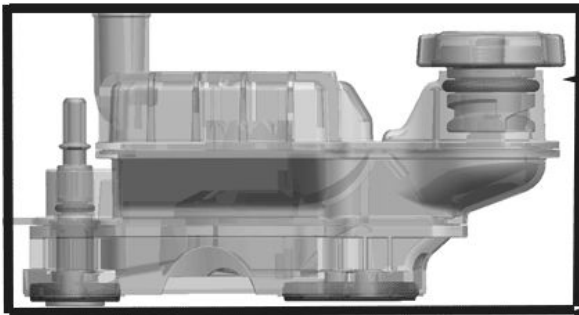

5053875

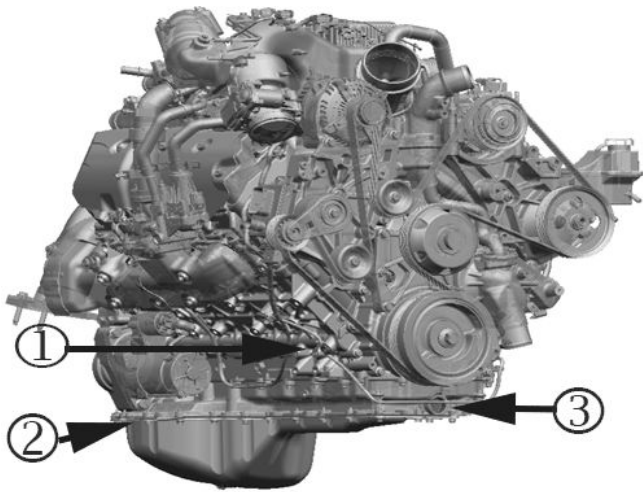

5053878

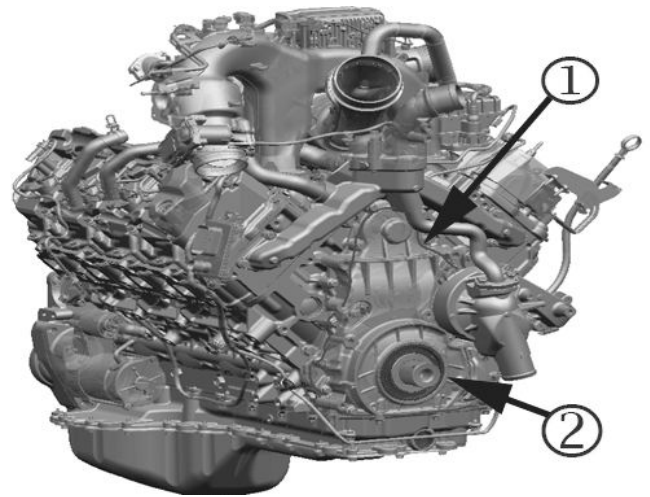

5053879

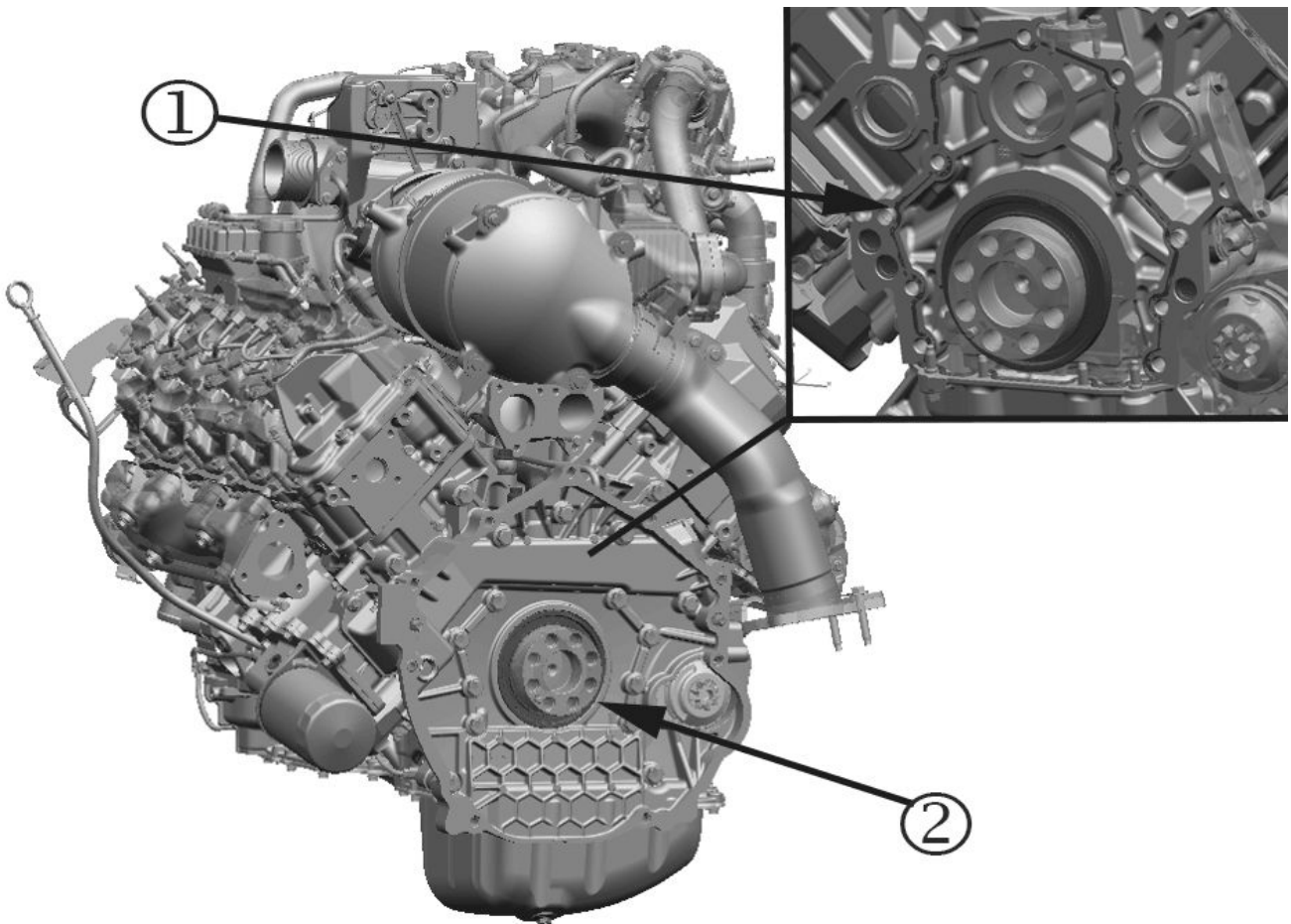

5053880

Note: (Flywheel Housing has been removed for clarity of picture)

Version	8
Modified	<p>Released May 04, 2018</p> <p>Revised July 25, 2018 – Added the 2019 Model Year.</p> <p>Revised June 24, 2019 – Added 2500/3500 to Models and 2020 to Model Year section.</p> <p>Revised October 19, 2020 – Added 2021 Model Years to 2500/3500 models and added 2019–2021 Silverado 4500, 5500 and 6500 HD Models and added RPO L5D.</p> <p>Revised January 07, 2022 – Added 2022 to Model Year.</p> <p>Revised September 09, 2022 – Added 2023 to Model Year.</p> <p>Revised March 17, 2023 – Added the 2024 Model Year to Silverado/Sierra 2500/3500 trucks, Australia/New Zealand to Involved Region or Country section and the Important statement.</p> <p>Revised August 14, 2025 - Added 2025 to Model Year.</p>

