



# Technical Service Bulletin

---

## 93 Q4 power transmission: clacking noises during load changes/when changing direction (e.g. maneuvering/driving away)

93 24 08 2074899/1 August 28, 2024.

Model(s)	Year	VIN Range	Vehicle-Specific Equipment
Q4 e-tron, and Q4 Sportback e-tron	2022 – 2025	All	Not Applicable

### Condition

#### Customer states:

- Clacking noises can be heard from the rear of the vehicle/motor compartment when driving away/changing direction in a forward gear or in reverse (e.g. when maneuvering).

*and/or*

- Clacking noises from the rear of the vehicle/motor compartment during load changes.

#### Workshop findings:

- One or both customer statements can be reproduced. The clacking noises can be clearly assigned to the gearbox.

- 

Not applicable.

### Production Solution

Not applicable.

### Service

#### Replacing retaining ring for input shaft

- Remove gearbox as described in ELSA Repair manual.



# Technical Service Bulletin

---

- Attach gearbox to engine and gearbox support -VAS6095A- as described in ELSA Repair manual.
- Drain gear oil via filler cap (refer to figure 1, red oval).

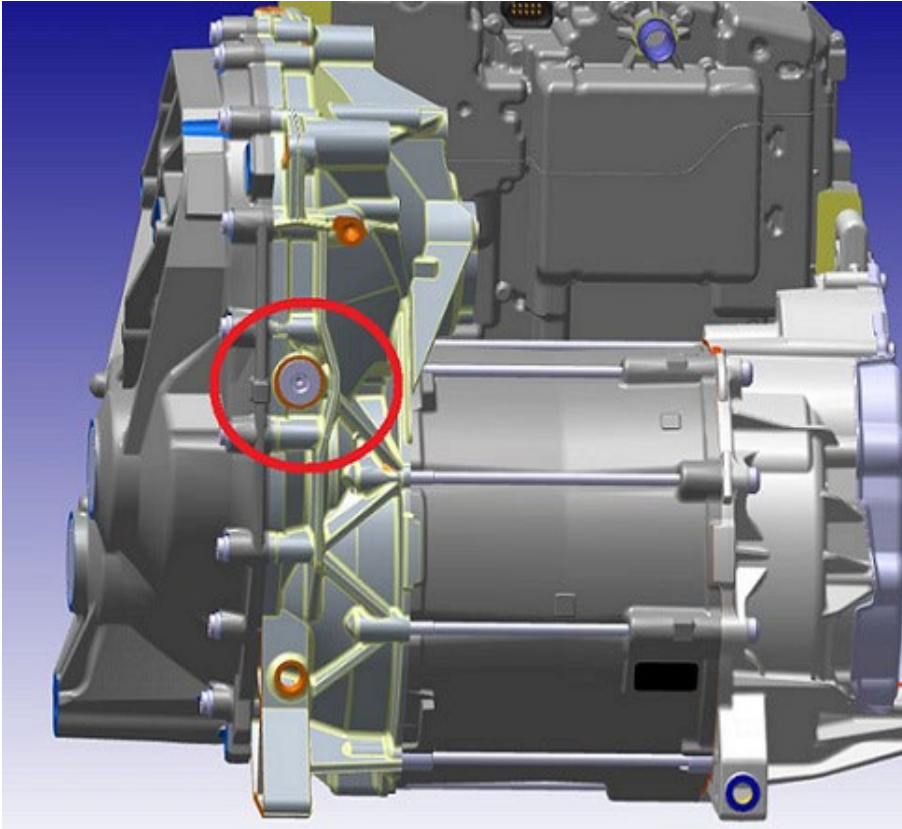

*Figure 1. Filler cap for gear oil.*

- Remove center filler cap using extractor lever -VW681- (refer to figure 2).



# Technical Service Bulletin

---



*Figure 2. Removing filler cap with extractor lever -VW681- (example).*

- Remove retaining ring for inner ring of intermediate shaft (refer to figure 3). The retaining ring must not be damaged and will need to be used again during the repair procedure.





# Technical Service Bulletin

---

*Figure 3. Removing retaining ring for inner ring of intermediate shaft (example).*

- Remove 17 housing bolts (refer to figure 4, red circles).

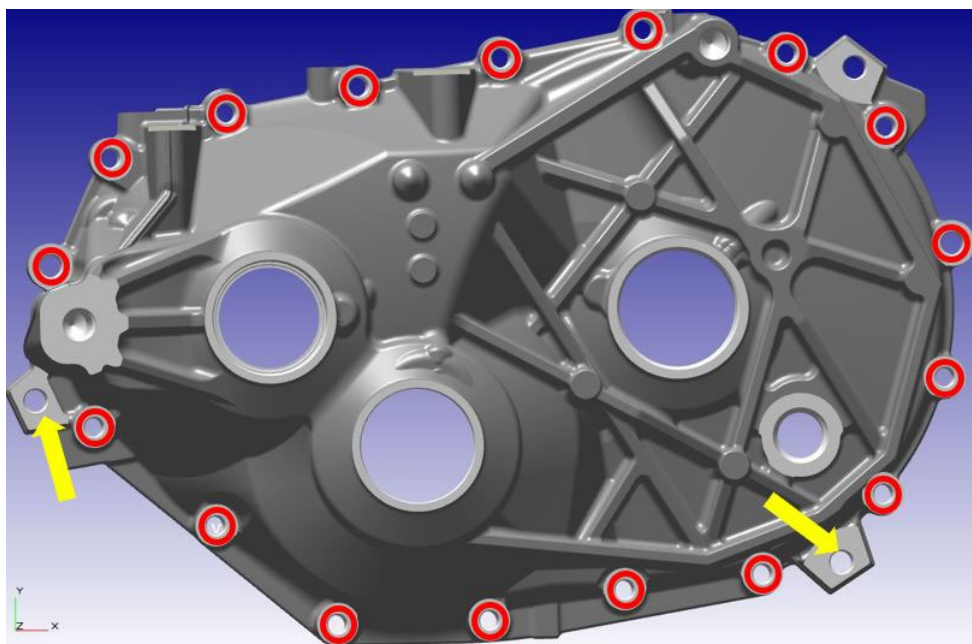

*Figure 4. Positions of housing bolts (red circles), position of contact points (yellow arrows).*

- Apply a commercially available assembly lever under the contact points (refer to figure 4 (yellow arrows), figure 5 and figure 6), carefully separate the two sections of the gearbox housing from each other and detach the gearbox housing.



# Technical Service Bulletin

---



*Figure 5. Separating sections of gearbox housing from each other using assembly lever.*



*Figure 6. Separating sections of gearbox housing from each other using assembly lever.*



# Technical Service Bulletin

---

- Remove oil reservoir (refer to figure 7, red arrow) from gearbox housing.
- Remove magnet (refer to figure 7, red oval) from gearbox housing.

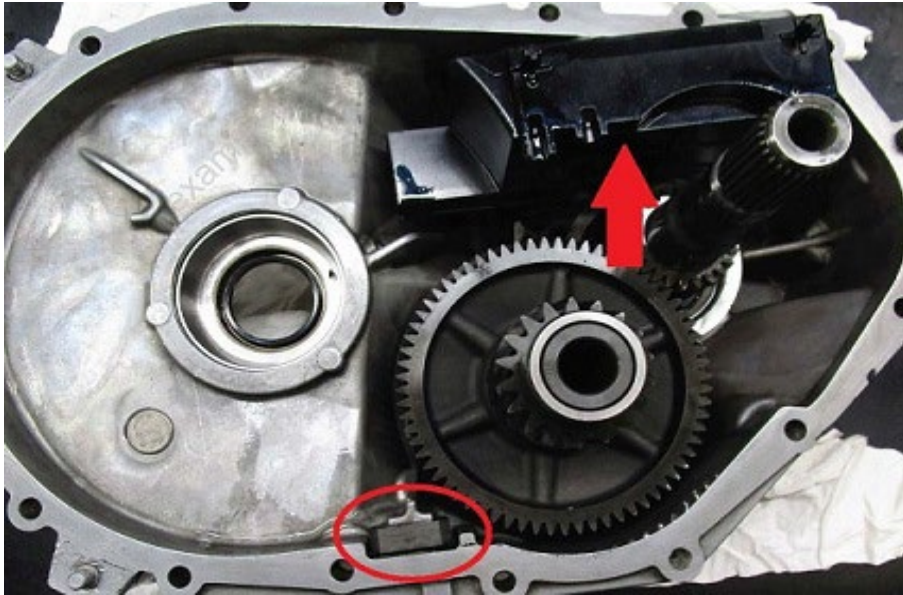

*Figure 7. Positions of oil reservoir and magnet in gearbox housing.*

- Press intermediate shaft out using removing and installing tool -VW459/2- (refer to figure 8).



# Technical Service Bulletin

---



*Figure 8. Pressing out intermediate shaft (example).*

- Remove retaining ring for outer ring (refer to figure 9) of bearing for intermediate shaft. The retaining ring must not be damaged and will need to be used again during the repair procedure.

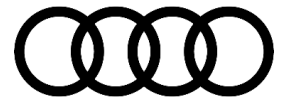

# Technical Service Bulletin

---



*Figure 9. Removing retaining ring (example).*

- Press bearing for intermediate shaft out using removing and installing tool -VW459/2- (refer to figure 10).



# Technical Service Bulletin

---



*Figure 10. Pressing out bearing for intermediate shaft (example).*

- Remove outer retaining ring for drive shaft (refer to figure 11).

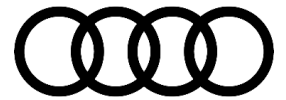

# Technical Service Bulletin

---

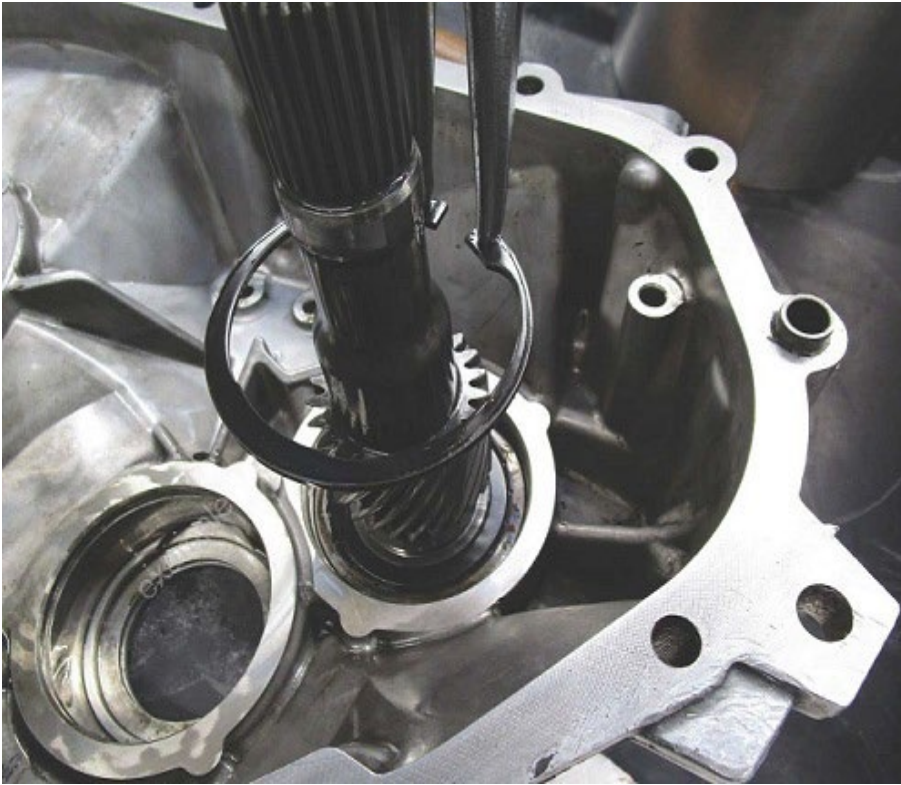

*Figure 11. Removing outer retaining ring for drive shaft (example).*

- Carefully drive bearing for drive shaft deeper into gearbox housing using a commercially available drift and hammer at outer ring of bearing (refer to figure 12).



# Technical Service Bulletin

---



*Figure 12. Driving bearing for drive shaft in deeper (example).*

- Install new retaining ring (with the maximum thickness/strength as described in parts information) as follows:
  - Install new retaining ring (starting with the maximum thickness/strength). If the retaining ring does not fit in the groove, try to insert the next thinnest retaining ring.
  - Continue in this way as necessary until a retaining ring of the correct size can be installed.

## NOTICE

The new retaining ring must snap fully into the groove (refer to figure 13, red oval).



# Technical Service Bulletin

---

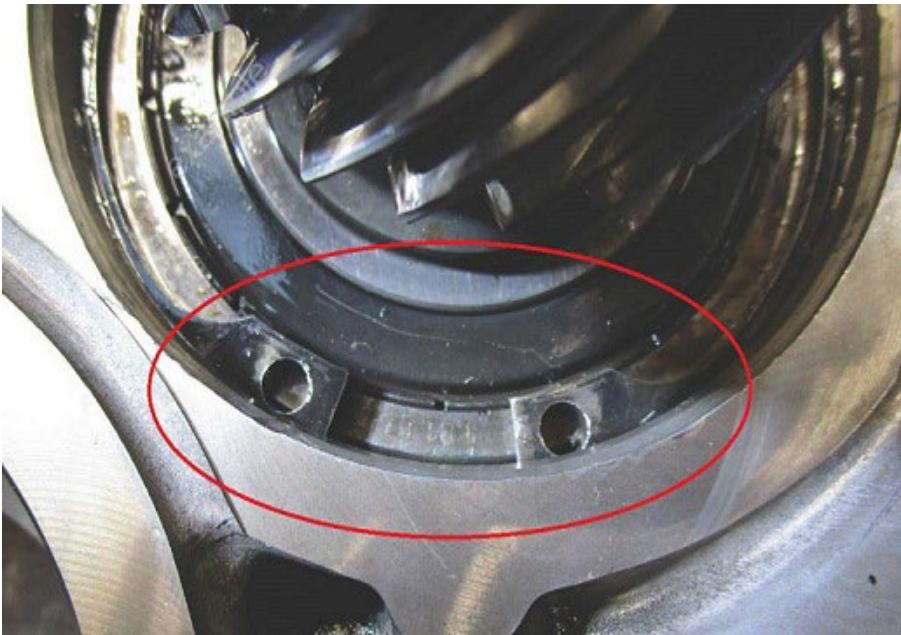
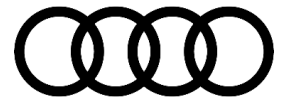

*Figure 13. Retaining ring has snapped fully into groove (example).*

- Press new bearing for intermediate shaft (as described in parts information) into gearbox housing with tube -3146- (refer to figure 14).



*Figure 14. Pressing in new bearing for intermediate shaft with tube -3146-.*



# Technical Service Bulletin

---

- Re-install retaining ring for outer ring of bearing for intermediate shaft.
- Press intermediate shaft in using removing and installing tool -VW459/2- (refer to figure 15); at the same time, support inner ring with thrust piece -VW454- (refer to figure 16).



*Figure 15. Pressing in intermediate shaft with removing and installing tool - VW459/2- (example).*



# Technical Service Bulletin

---



*Figure 16. Supporting inner ring with thrust piece -VW454- (example).*

- Re-install retaining ring for inner ring of intermediate shaft.
- Thoroughly clean the sealing surfaces of the gearbox sections with cleaning solution (part number: D 291 091 A1).

## NOTICE

**The cleaning solution (part number: D 291 091 A1) activates the surfaces before the sealant is applied and must be used to ensure the sealant creates a functional sealing bond.**

- Allow flash-off time of 10 minutes for sealing surfaces.
- Apply silicone sealant (part number: D 176 650 M1) all around sealing surface of intermediate housing (refer to figure 17).

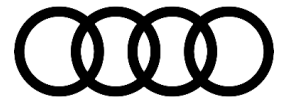

# Technical Service Bulletin

---

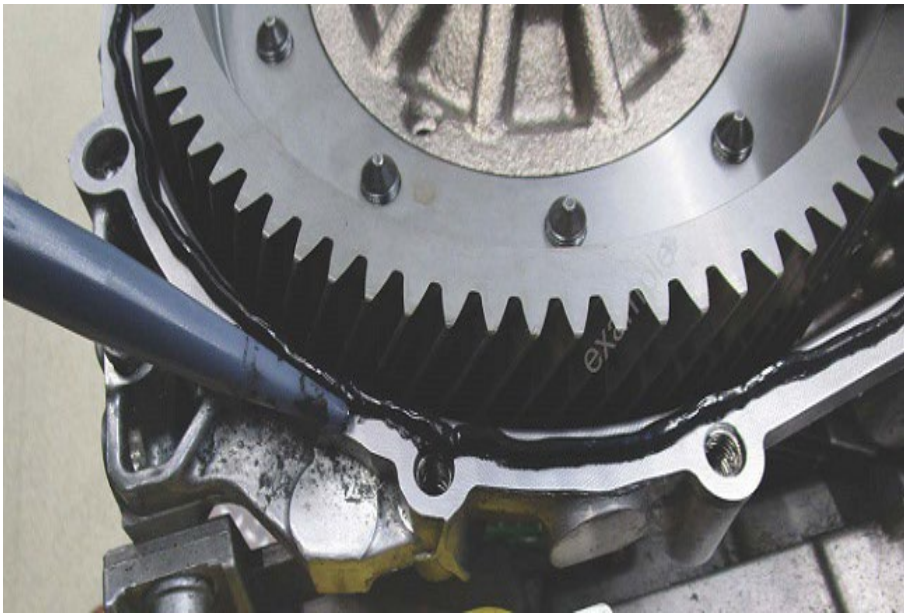

*Figure 17. Applying silicone sealant all around sealing surface of intermediate housing (example).*

- Bond previously removed magnet (refer to figure 18) into gearbox housing using silicone sealant (part number: D 176 650 M1).

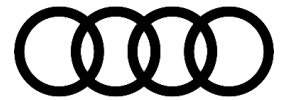

# Technical Service Bulletin

---



*Figure 18. Magnet with silicone sealant (example).*

- Lightly apply silicone sealant (part number: D 176 650 M1) to previously removed oil reservoir at 3 attachment points (refer to figures 19 and 20) with.



# Technical Service Bulletin

---

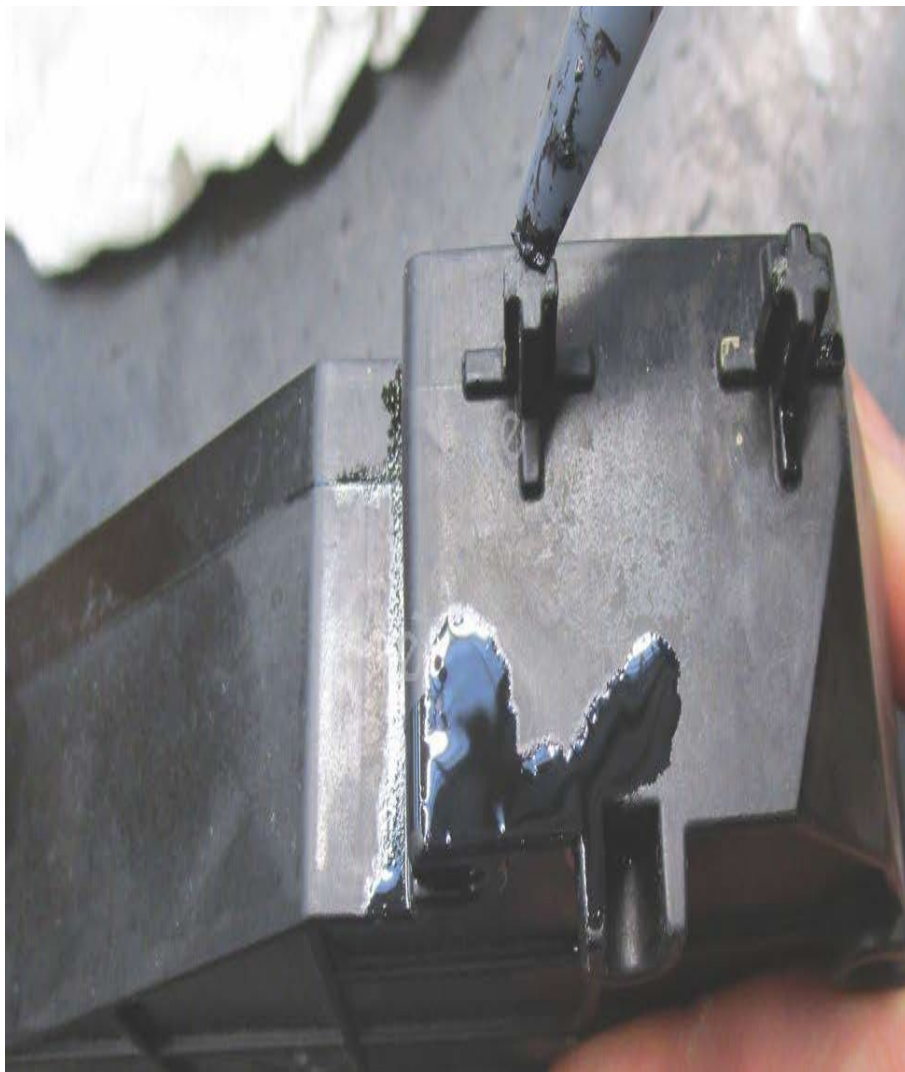

*Figure 19. Lightly applying silicone sealant to attachment point (example).*



# Technical Service Bulletin

---



*Figure 20. Lightly applying silicone sealant to attachment point (example).*

- Fit oil reservoir (refer to figure 21, red oval) in intermediate housing.



# Technical Service Bulletin

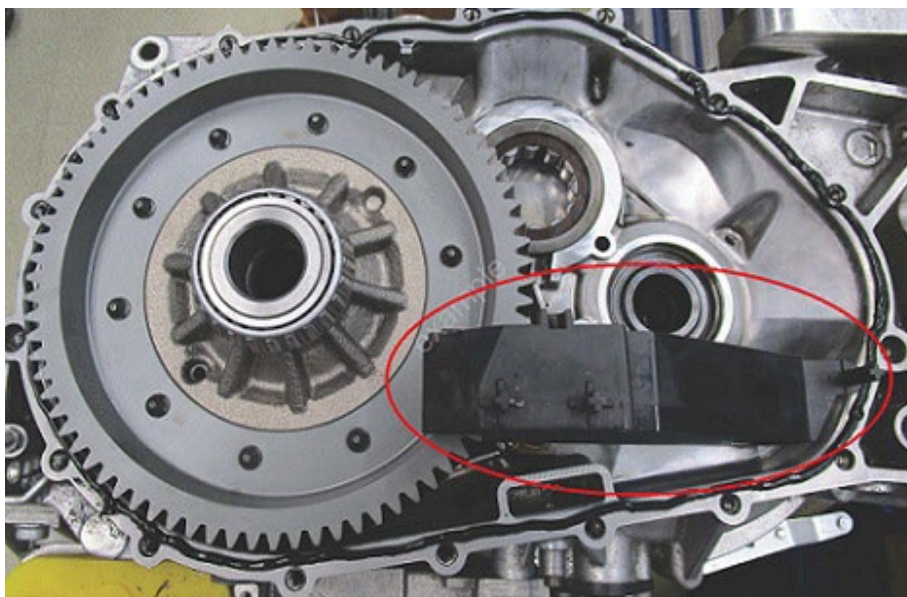
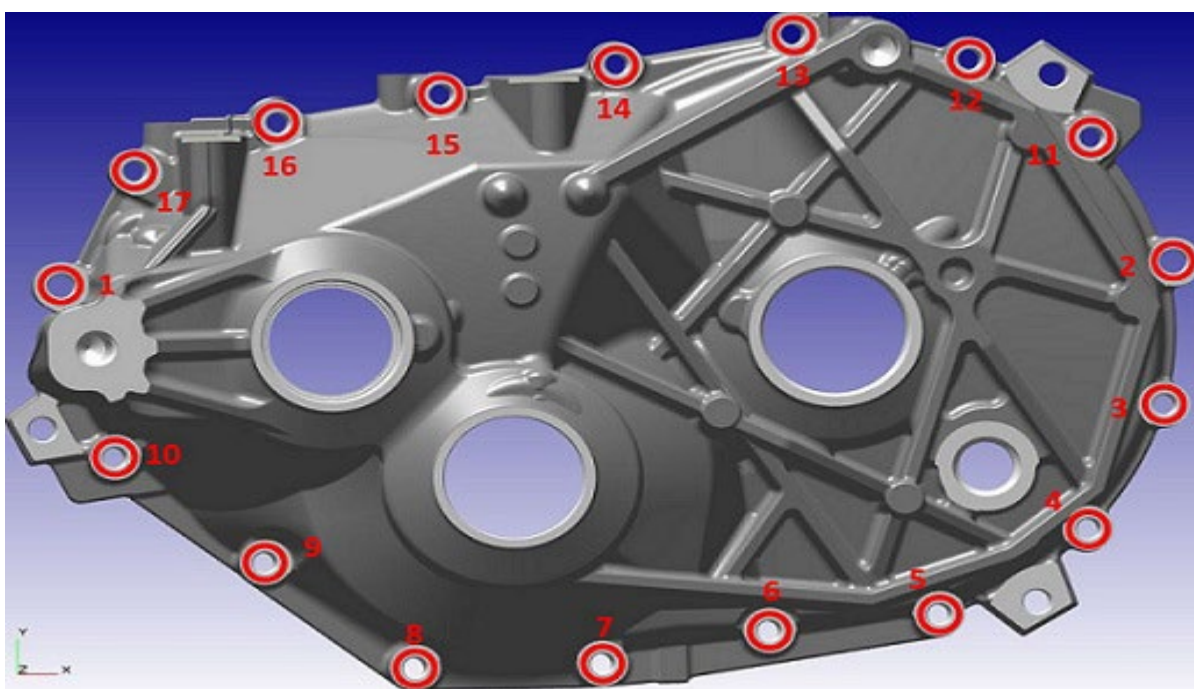
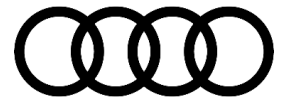

Figure 21. Oil reservoir fitted in intermediate housing.

- Place gearbox housing on intermediate housing.
- Install gearbox housing by screwing in new multi-point socket head bolts in the sequence 1 to 17 (refer to figure 22); **tightening torque: 20 Nm + 90°** .





# Technical Service Bulletin

Figure 22. Installing multi-point socket head bolts; tightening torque 20 Nm + 90° .

- Install new (center) filler cap (part number can be found under parts information).
- Replace oil seals as described in ELSA Repair manual/parts information.
- Install new filler cap for gear oil (part number can be found under parts information); **tightening torque: 45 Nm.**
- Remove gearbox from engine and gearbox support -VAS6095A-.
- Install gearbox as described in ELSA Repair manual.
- Fill gearbox with gear oil as described in ELSA Repair manual.
- Perform a road test:
  - If the clacking noise **can no longer be heard**, the measure ends here. The vehicle can be returned to the customer.
  - If the clacking noise **can still be heard**, please open a web ticket with the Technical Assistance Center (TAC).

## Warranty

<b>Claim Type:</b>	<ul style="list-style-type: none"> <li>• If the vehicle is outside of any warranty, this Technical Service Bulletin is informational only.</li> </ul>		
<b>Service Number:</b>	3561		
<b>Damage Code:</b>	0010		
<b>Labor Operations:</b>	Charge Battery	2706 8950	See SRT with associated operations
	Remove and install front electric drive motor <i>(If front electric drive is affected)</i>	9340 19XX	See SRT with associated operations
	Service front electric drive motor	9340 4199	150 TU

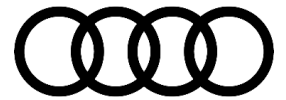

# Technical Service Bulletin

	<i>(If front electric drive is affected)</i>		
	Remove and install rear electric drive motor <i>(And/or if rear electric drive is affected)</i>	9346 19XX	See SRT with associated operations
	Service rear electric drive motor <i>(And/or if rear electric drive is affected)</i>	9346 4199	150 TU
<b>Diagnostic Time:</b>	GFF/Guided Functions	0150 0060	Time stated on the diagnostic protocol
	Road test prior to the service procedure	0121 0002	10 TU
	Road test after the service procedure	0121 0004	10 TU
<b>Claim Comment:</b>	As per TSB 2074899/1		

All warranty claims submitted for payment must be in accordance with the *Audi Warranty Policies and Procedures Manual*. Claims are subject to review or audit by Audi Warranty.

## Required Parts and Tools

The part numbers mentioned in this TSB are different than the ones listed in ETKA. Only use parts listed in this TSB, this includes superseding part numbers!

Part number	Part Description	Quantity
N 911 021 01	Socket head bolt with multi-point socket head (M8x45)	17
D 176 650 M1	Silicone sealant	1
N 012 295 6	Retaining ring (72x2.75)	1
N 012 295 5	Retaining ring (72x2.70)	1
N 012 295 4	Retaining ring (72x2.65)	1
N 012 295 3	Retaining ring (72x2.60)	1

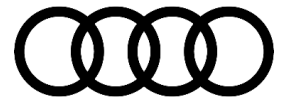

# Technical Service Bulletin

---

0GC 301 211	Sealing cap	1
0MH 311 235	Deep-groove ball bearing	1
0MH 409 189 B	Oil seal	2
D 291 091 A1	Cleaning solution	1
WHT 003 487	Plug	1

Tool Number	Tool Description
VAS6095A	Gearbox Support
VW681	Extractor Lever
VW459/2	Removing and Installing Tool
VW454	Thrust Piece
3146	Tube

## Additional Information

All parts and service references provided in this TSB (2074899) are subject to change and/or removal.

©2024 Audi of America, Inc. All rights reserved. The information contained in this document is based on the latest information available at the time of printing and is subject to the copyright and other intellectual property rights of Audi of America, Inc., its affiliated companies, and its licensors. All rights are reserved to make changes at any time without notice. No part of this document may be reproduced, stored in a retrieval system, or transmitted in any form or by any means, electronic, mechanical, photocopying, recording, or otherwise, nor may these materials be modified or reposted to other sites without the prior expressed written permission of the publisher.